

Installation Instructions

IMPORTANT SAFETY INSTRUCTIONS

When using your video equipment, basic safety precautions should always be followed, including the following:

1. Read and understand all instructions before using.
2. Position the cord so that it will not be tripped over, pulled, or contact hot surfaces.
3. If an extension cord is necessary, a cord with a current rating at least equal to that of the appliance should be used. Cords rated for less amperage than the appliance may overheat.
4. To reduce the risk of electric shock, do not disassemble this appliance. Contact an authorized service dealer when repair work is required. Incorrect reassembly can cause electric shock when the appliance is used subsequently.
5. The use of an accessory attachment not recommended by the manufacturer may cause a risk of fire, electric shock, or injury to persons.

SAVE THESE INSTRUCTIONS

PRE-INSTALLATION

1. Carefully unpack screen and remove outer wrapping from case.
2. Do not remove black tape from screen.
3. Always handle screen in upright position.

INSTALLATION

There are three methods of mounting to include: Flush against wall; Suspended from ceiling (use extension brackets); and Recessed above ceiling.

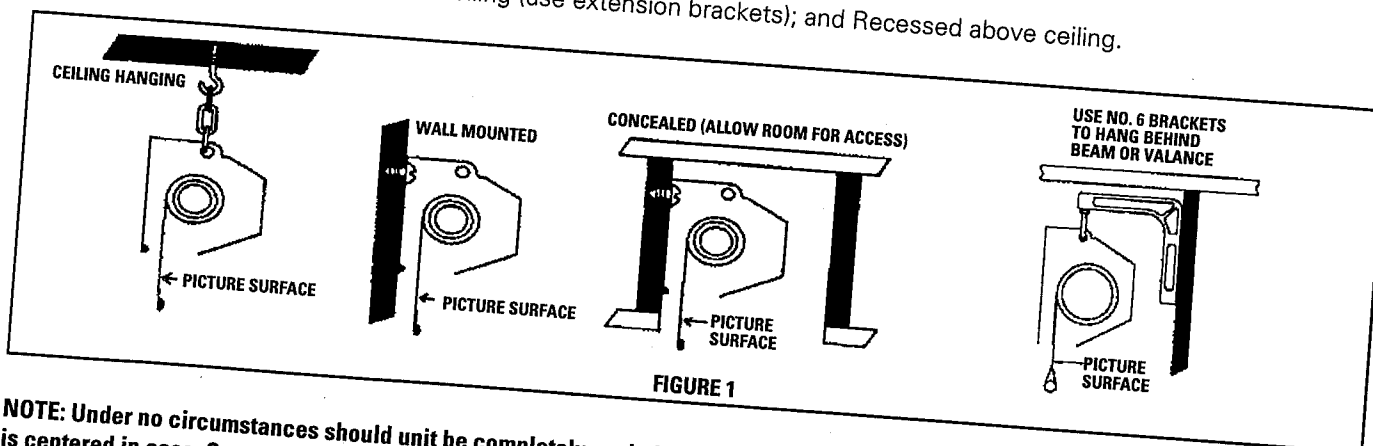

NOTE: Under no circumstances should unit be completely sealed in recessed installation. Allow access for service. Picture surface is centered in case. Case extends 4" beyond surface on either end. Do not attach anything to screen slat rod or bottom fabric pocket.

1. Make sure screen is level. Use a carpenter's level and plum level.
CAUTION! Do not cut wrapping paper or tape with knife or any sharp tool. Remove by hand.
2. Remove tape from slat pocket.
3. Install electrical hook up that applies to your unit. Make sure to review your Electrical Installation Checklists and wiring diagrams (included) for either 120 volt switch, 220/240 volt switch, or DRC low voltage control.

SCREEN ADJUSTMENT

Surface travel is stopped automatically in the fully opened and closed positions by limit switches that are properly adjusted at the factory. Should it be necessary to adjust for more or less picture drop (viewing area), proceed in the following manner:

NOTE: Use a screwdriver or allen wrench to make adjustments.

MORE SCREEN DROP

1. Place operating switch in "down" position.
2. When the screen stops, turn the white "down" limit knob (Fig. 3) one-quarter turn counter-clockwise. Test by raising picture surface approximately two feet, then lower again. Repeat until desired picture surface position is attained.

LESS SCREEN DROP

1. Raise picture surface approximately two feet above desired level.
2. Place operating switch in "off" position.
3. Turn the white "down" limit knob one-quarter turn clockwise. Test by raising picture surface approximately two feet, then lower again. Repeat until desired picture surface is attained.

NOTE: The yellow UP adjusting knob is located at motor end and is accessible through the fabric opening. The white DOWN adjusting knob is located at motor end and is accessible through the fabric opening.

CAUTION! When adjusting and testing, be prepared to stop screen quickly as serious damage may occur.

INSTALLATION

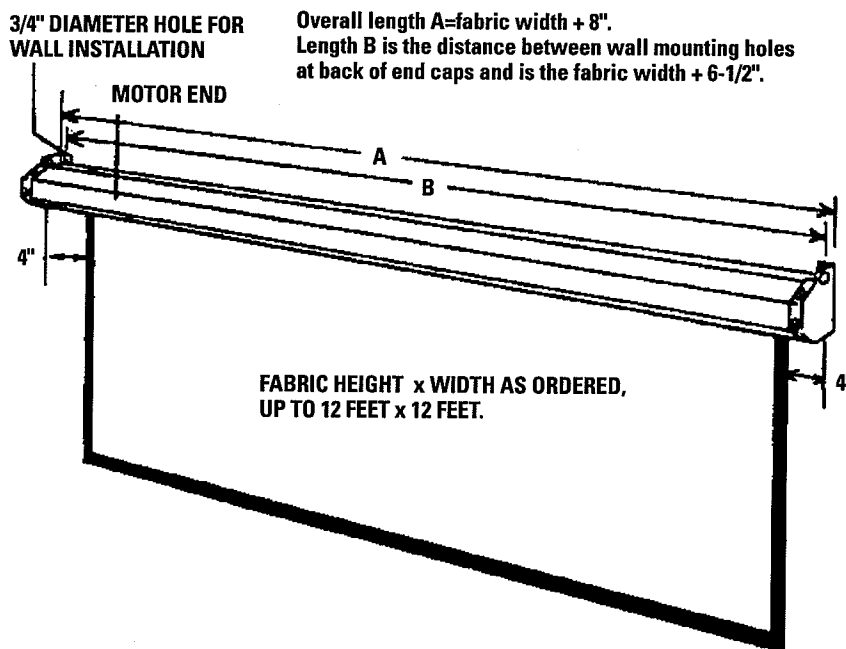
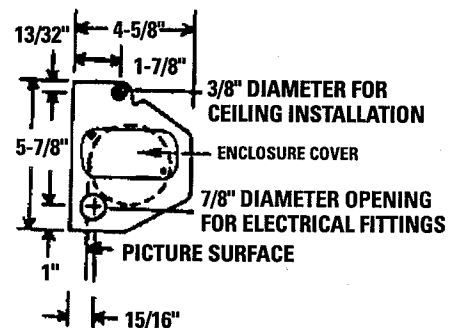
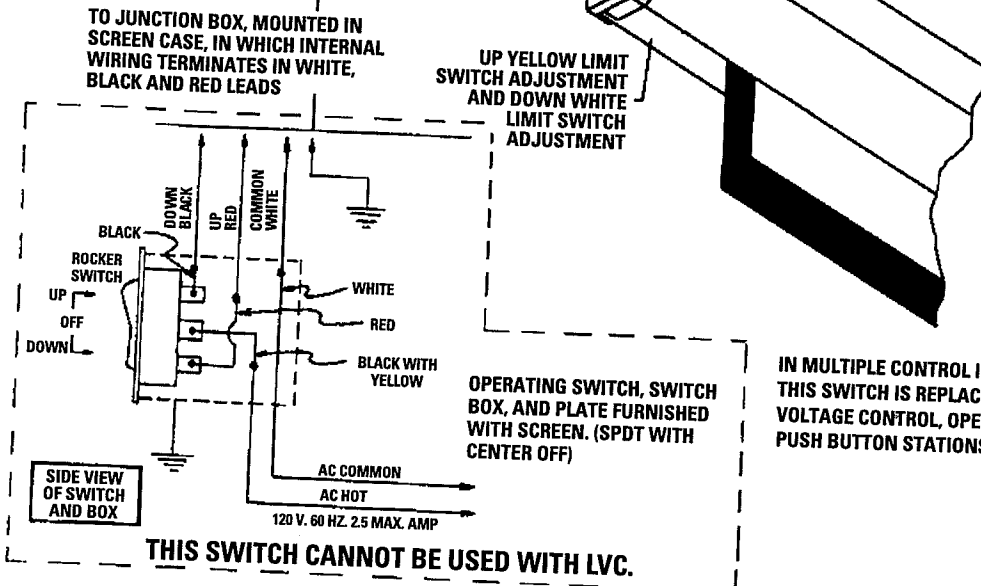

FIGURE 2



INSTALLATION

120V WIRING DIAGRAM



NOTE: A single switch cannot be used to operate more than one screen. Contact the factory for further information.

FIGURE 3

220 / 240V WIRING DIAGRAM

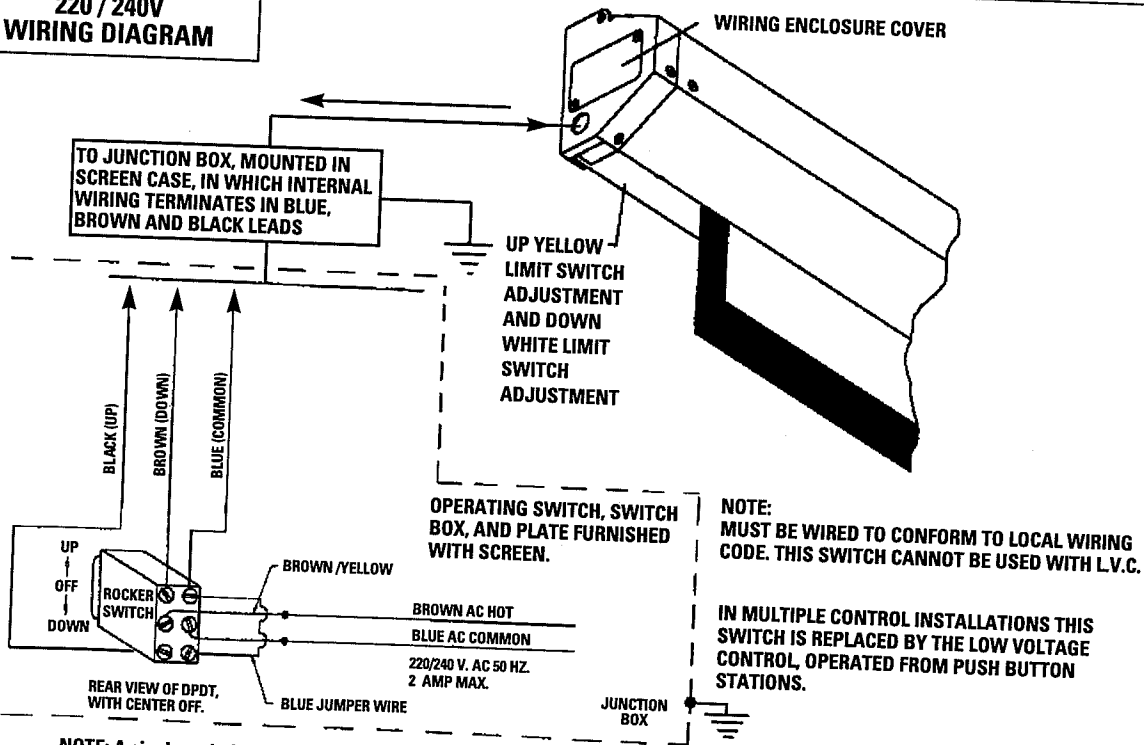

NOTE: A single switch cannot be used to operate more than one screen. Contact the factory for further information.

FIGURE 3

TROUBLESHOOTING

SYMPTOM	CAUSE	SOLUTION
<p>1. Screen will not operate or will not go "down". Motor does not hum.</p> <p>Motor hums.</p>	<p>(a) Blown fuse. (b) Tripped circuit breaker. (c) No power to operating switch or junction.</p> <p>Power at junction box</p> <p>(d) Thermal overload tripped. (e) Broken wire in the "down" position. (f) Defective motor, limit switch or capacitor. (g) Temporary binding. (h) Capacitor burned out.</p>	<p>(a) Replace fuse. (b) Reset circuit breaker. (c) Check above. Tighten all loose wire connections. Correct any improper connections.</p> <p>"Down" Position Check for power across black and white leads.</p> <p>(d) Let motor cool down for 15 minutes. Try again. (e) Check for continuity. Cut off old splice and reconnect.</p> <p>(f) Replace motor assembly. NOTE: Motor is a sealed assembly. (g) With power "off", turn roller by hand to free binding. (h) Replace motor assembly.</p>
<p>2. Screen will not move "up" Motor does not hum</p> <p>Motor hums.</p>	<p>(a) Blown fuse. (b) Tripped circuit breaker. (c) No power to operating switch or junction.</p> <p>Power at junction box</p> <p>(d) Thermal overload tripped. (e) Broken wire in the "up" position. (f) Defective motor, limit switch or capacitor. (g) Temporary binding. (h) Capacitor burned out.</p>	<p>(a) Replace fuse. (b) Reset circuit breaker. (c) Check above. Tighten all loose wire connections. Correct any improper connections.</p> <p>"Up" Position Check for power across red and white leads.</p> <p>(d) Let motor cool down for 15 minutes. Try again. (e) Check for continuity. Cut off old splice and reconnect.</p> <p>(f) Replace motor assembly. NOTE: Motor is a sealed assembly. (g) With power "off", turn roller by hand to free binding. (h) Replace motor assembly.</p>

TROUBLESHOOTING

SYMPTOM	CAUSE	SOLUTION
3. Incorrect stopping position in downward direction.	(a) Lost roller wrap. (b) "Down" limit switch out of adjustment	(a) See instructions below. (b) See installation instructions.
4. Incorrect stopping position in upward direction.	(a) Lost roller wrap. (b) "Up" limit switch out of adjustment	(a) See instructions below. (b) Adjust "up" limit switch. Turn clockwise to expose more fabric. See installation instructions
5. Noise. NOTE: Screen will operate with a low pitched hum.	(a) Squeaking rubber end plug rubbing on motor. (b) Grinding due to foreign object in screen rubbing on roller or fabric. (c) Gear noise.	(a) Adjust roller to center of case. (b) Remove foreign object. (c) Replace motor assembly.
6. Coasting.	(a) Defective brake.	(a) Replace motor assembly.
7. Roller displaced from mounting bracket.	(a) Pin end slipped out of nylon bearing.	(a) Remove pin end mounting. Re-align motor in tube. Re-attach pin end.

RESTORING LOST ROLLER WRAP

1. Push strap over back of roller.
2. Tape end of strap to pocket.
3. Feed fabric as you pull strap to draw fabric over top.
4. Remove tape and strap.