

The products of Pro Co Sound, Inc.

January 1, 2004

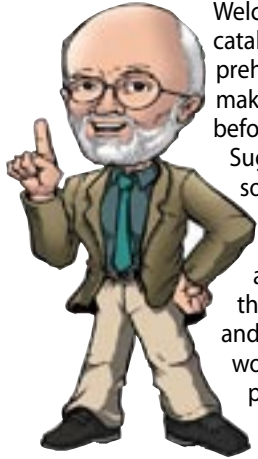

Welcome



Welcome to the second full-line Pro Co catalog. We hope the new format and comprehensive listing of our standard products makes your selection process easier than ever before.

Suggested Resale prices are included so this catalog can be seen and used by everyone, dealers and customers alike.

As plumbers to the audio trades, we also will custom design and build anything you need to get your system wired up and running, from snakes and cables to Plateworks laser-engraved metal termination panels, to bulk parts to custom patchbays.

If it goes between the hardware components of an audio system, we make it.

A dealer pricing guide is available to authorized customers, in paper form, on a CD or on the website. Dealers are provided with passwords to access this information.

Thank you for a wonderful 29 years.

Warmest Personal Regards,

Charlie Wicks,

Connector and Wire Codes

AWG	American Wire Gauge
B	Dual Banana Plug
BLK	Black
BQ	Balanced Quarter Phone Plug
BQF	Balanced Quarter Phone Inline Jack
C	Blunt Cut
DF	DB25 Female (D-Sub Female)
DM	DB25 Male (D-Sub Male)
G	Gold
HD	Heavy Duty
IDC	Solderless (Insulation Displacement Connection)
LB	Large Barrel
LD	Large Hole
M	Mini Plug
MB	Balanced Mini Plug
MF	Mini Inline Jack (Female)
MBF	Balanced Mini Inline Jack (Female)
Ni	Nickel Shell Finish
N	Neutrik Speakon
P	Plastic Shell Finish
PJ	Mil Spec 1/4" Balanced Plug
Q	Unbalanced Quarter Phone Plug
QF	Unbalanced Quarter Phone Inline Jack (Female)
QP	Unbalanced Quarter Phone Silent Plug
R	RCA Plug
RA	Right Angle
RF	RCA Inline Jack (Female)
S	Silver Contacts
SS	Stainless Shell Finish
SW	XLR Female with On/Off Switch
TFSR	Transformer
TT	Bantam Phone Plug
XF	XLR Female
XM	XLR Male
WT	Watertight

Pin Configuration Icons

	FEMALE 3-PIN		MALE 3-PIN
	FEMALE 4-PIN		MALE 4-PIN
	FEMALE 5-PIN		MALE 5-PIN
	FEMALE 6-PIN (Neutrik)		MALE 6-PIN (Neutrik)
	FEMALE 6-PIN (Switchcraft-compatible)		MALE 6-PIN (Switchcraft-compatible)
	FEMALE 7-PIN		MALE 7-PIN
	1/4" PHONE JACK		3.5mm MINI JACK
	FEMALE RCA		MALE RCA
	FEMALE SPEAKON		MALE SPEAKON
	MALE 5-PIN DIN		FEMALE BNC

Table of Contents

Instrument Cables

Defender.....	2
Sir Tweed	2
Excalibur.....	2
ProPatch.....	3
Excellines.....	3
StageMASTER	3

Microphone Cables

Merlin.....	4
AmeriQuad	4
MasterMike	4
Excellines.....	5
StageMASTER	5

Speaker Cables

Fat Max (8 guage).....	6
PowerPlus (12 guage)	6
Excellines (14 & 16 guage).....	6-7
PowerPlus (11 & 13 guage)	8
1/4" Phone Plug to 1/4" Phone Plug	8
1/4" Phone Plug to Dual Banana Plug..	8
Dual Banana Plug to Dual Banana Plug.....	9
1/4" Phone Plug to 2- Conductor Speakon.....	9
Dual Banana Plug to Speakon	10
Speakon to Speakon	10
Multiple Circuit Speaker Cables	11
Adapter Speaker Cables.....	11
StageMASTER	11

Analog Patch Cables

Single Unbalanced Patch (P) Cables...	12
Dual unbalanced Keyboard (DK) Patch Cables	12
Rac-Kables (RK).....	13
PJ (Phone Jack) Cables	13
TT (Tiny Telephone or "Bantam" Plug) Cables.....	14
"Y" Cords	14
Insert Patch Cables.....	15
Ameriquad Balanced Patch Cables	16
Balanced Patch Cables.....	17
Camcorder Cables	17
Sound Card Cables.....	18

Digital Patch Cables

MIDI (Musical Instrument Digital Interface) Cables	19
S/P DIF (Sony/Philips Digital Interface Format)	19
AES/EBU (Audio Engineering Society/European Broadcast Union)	19
DMX Lighting Control Cable	19

Electrical Extension Cords

E-Cords	20
---------------	----

MultiTrack Cables

Alesis ADAT Multitrack Recording Cables.....	21
Analog D-Sub (DB25) Multitrack Recording Cables.....	21
Analog Studio Harness Cables.....	22
Insert Patch Snakes.....	23
Digital Multitrack Recording Harnesses	23

Snakes

StageMASTER Snakes	24
RoadMASTER Snakes.....	25
ConcertMASTER Brand Professional Touring Snakes	26

Options

Instrument Cables.....	27
Microphone Cables.....	27
Speaker Cables.....	27

Trade Tools

Direct Boxes.....	28
Cough Suppressors	28
Interface Boxes.....	29
Signal Isolators	30
Microphone Combiner	30
Microphone Splitters	31
Line Level Splitter	31
Microphone Splitters	32
Monitor Speaker Selectors.....	32
Retail Demonstration Switchers	33
Kwik Fixer Series.....	34

PatchBays

PJ.....	35
TT.....	35

Rats

Vintage Rat	36
Rat 2	36
TurboRat	36
You Dirty Rat	36
DeuceTone Rat	37
Juggernaut Bass Rat	37

Plateworks Standard Wallplates

Blank and Punched Only Wallplates	38
1-3 Gang Loaded with Female XLRs.....	38-39
1-3 Gang Loaded with Male XLRs	40-41
1-2 Gang Loaded with 3-Conductor 1/4" Phone Jacks	41
1-2 Gang Loaded with Neutrik Speakons	42
1 Gang Loaded with RCA Jack(s)	42
1-2 Gang Loaded with Female XLR and 3-Cond. Phone Jacks	42
1-2 Gang Loaded with BNC Connectors	43
1 Gang Loaded with 5-pin XLR Connectors (DMX)	43
1-2 Gang Loaded with F-Type Connectors.....	43
Plateworks Standard Wallplates Resale Pricing	44-46
Straight Plates.....	47

Lamacoid Markers

Lamacoid Marker Variety Sets.....	48
-----------------------------------	----

Plateworks Standard Floor Pockets

Floorpockets	49
Concrete Pour Boxes	49
Pro Co Floor Pockets Overview	50
Standard Unloaded Connector Plates.....	51
Connector Plate Wiring Channel	51
FP2 Series	52
FP6 Series	53

Essentials

Bulk Audio Cable	54
Bulk Connectors.....	56
CC-L Connector Center Display	56
WC-L Wire Center Display.....	56

Bulk Parts

Neutrik XLR-type Connectors	57
Neutrik Speakon Speaker Connectors.....	58
Neutrik 1/4" Connectors.....	59
G&H Industries Audio Connectors	60
Pro Co Transformers	61
Pro Co Connectors	61-63
Pro Co Adapters	64

Instrument Cables

Defender



Specifically designed to help reduce noise created by single coil pickups, Defender's quad wire, lifted-ground construction is based on 70-year-old Transmission Line Theory — no magic, just a well-engineered way to reduce irritating hum, buzz and crackle.

- Gold-plated 1/4" copper-core ShowSavers™ brand phone plugs standard
- AmeriQuad™ noise-reducing geometry, 96% braided shield bulletproof Kevlar reinforced cable core, Pro Co's Armorflex™ jacket

- Free Velcro cable tie
- Really flexible, really quiet, really strong, adding no sound of its own
- Lifetime warranty — any excuse, even abuse

Model Number	Length in Feet	Suggested Resale
DF-10	10	\$66.49
DF-15	15	\$71.49
DF-20	20	\$78.99
DF-25	25	\$85.99

Sir Tweed



With a true Nylon vintage-look over-braid and Kevlar reinforced cable core, Sir Tweed is one handsome cable. Built for a lifetime of use and abuse, the 41-strand center conductor and a 90% braided copper shield provide superior noise rejection while retaining impressive flexibility.

- Classic Tweed look, great sound and indestructible construction
- Gold-plated 1/4" copper-tipped ShowSavers brand phone plugs standard
- Bullet proof Kevlar reinforced core

- Free Velcro cable tie
- Looks great on stage with acoustic-electric guitars and many old Pauls
- Lifetime warranty — any excuse, even abuse

Model Number	Length in Feet	Suggested Resale
TW-10	10	\$69.49
TW-15	15	\$77.49
TW-20	20	\$84.99
TW-25	25	\$95.49

Also available with Cocobola wood handles.

Excalibur



The flashiest guitar cable on earth. From its high-luster exotic nickel ShowSavers connectors to its low capacitance 90% spiral-shielded cable, Excalibur provides outstanding flexibility, durability and incredible stage presence.

- Premium quality tour-grade cable
- Nickel-plated 1/4" copper-tipped custom designed ShowSavers brand phone plugs standard
- Free Velcro cable tie
- Incredible looking high-luster handles
- 20-year warranty

Model Number	Length in Feet	Suggested Resale
XG-10	10	\$48.49
XG-15	15	\$51.49
XG-20	20	\$54.49
XG-25	25	\$56.99

Several connector options, such as right angle plugs and gold or nickel connectors are available. See page 27 for details and pricing.

Instrument Cables

ProPatch



New for 2002

A new addition to Pro Co's instrument cable line in 2002, Pro Patch features black ShowSavers connector handles and Pro Co's Armorflex-jacketed 120SX oversized jacket for a handsome cable with no mechanical handling noise and tremendous flexibility. A step up from Excellines in looks, flexibility and durability, Pro Patch offers all this without getting into the higher costs of our exotic, extra-performance products.

- Cosmetically "cool"
- Lies down flat on stage and follows you everywhere effortlessly
- Right angle to right angle cable

- versions make great heavy-duty pedalboard connections
- 10 year warranty

Model Number	Length in Feet	Suggested Resale
PP-1	1	\$16.49
PP-3	3	\$17.49
PP-5	5	\$18.49
PP-10	10	\$19.99
PP-15	15	\$21.99
PP-20	20	\$23.99
PP-25	25	\$25.99
PP-30	30	\$27.99

Excellines



Since 1982, Excellines have been Pro Co's standard guitar cables. Using ShowSavers standard 1/4" connectors and 23rd generation Pro Co 120S1 wire, and the blue "widget" strain relief under each connector (the cable's trademark), Excellines already have offered over a million users a sturdy, reliable cable. Cheap because of the huge volumes built, Excellines offer one of the best price to value ratios in the audio cable business.

- Basic sturdy guitar cables with all components 100% made and assembled in America
- No off shore "made in somewhere else" stickers to look for

- Long lasting cables for musicians on a tight budget who are looking for cables cheap, not cheap cables
- 10-year warranty

Model Number	Length in Feet	Suggested Resale
EG-1	1	\$12.49
EG-2	2	\$12.99
EG-3	3	\$13.49
EG-5	5	\$13.99
EG-10	10	\$14.99
EG-15	15	\$15.99
EG-186	18.5	\$16.99
EG-25	25	\$18.99
EG-30	30	\$19.99

StageMASTER



There is always a need for inexpensive products, for starving musicians, civic and religious groups with limited budgets, for price sensitive buyers and for applications in which wear and tear just do not exist.

StageMASTER guitar cables are inexpensive and like all Pro Co guitar cables are still 100% made in America with 100% American-made parts.

Model Number	Length in Feet	Suggested Resale
SEG1	1	\$7.99
SEG3	3	\$8.49
SEG5	5	\$8.99
SEG10	10	\$10.49
SEG186	18.5	\$13.49
SEG25	25	\$15.49

Several connector options, such as right angle plugs and gold connectors are available. See page 27 for details and pricing.

Microphone Cables

Merlin



Designed specifically for hostile environments (electronic news gathering, sportscasting, underwater recording), Merlin uses Pro Co's 96% braided shield, ArmorFlex 424BX₂K (4-conductor, 24 gauge, braided shield Kevlar in the core, super thick jacket) wire and Neutrik NC3FXB-HD and NC3MXB-HD gold contact, watertight XLR connectors to provide a quiet, flexible, unbreakable cable for situations where a retake is impossible or totally out of the question. The cable's quad construction eliminates up to 20 db more noise than anyone's two conductor mic cables, including our own.

- For all practical purposes, unbreakable
- Gold contacts for use in moist/wet

environments (outdoor recordings, live broadcasts)

- Incredibly flexible, follows the user wherever s/he may go on stage
- Lays down flat, easy to coil
- Watertight, completely submersible use intended
- Free Velcro cable tie
- Lifetime warranty — any excuse, even abuse

Model Number	Length in Feet	Suggested Resale
ME-15	15	\$74.49
ME-20	20	\$79.99

AmeriQuad



Using Pro Co's 424BK (4-conductor, 24 gauge, 96% braided shield, Kevlar in the core) wire, and bi-wire technology, AmeriQuad is our premium cable for church systems, touring sound systems and other situations where high RFI fields may present a noise problem. The bi-wire technology adds up to 20 db more noise rejection than a regular 2-conductor cable (it acts like much less of an antenna to the system). Needed where "Come back, good buddy!" and other such annoying problems must be avoided at all costs.

- Reduces system noise considerably
- Black Neutrik connector, gold contacts
- Lays down flat, easy to coil

Model Number	Length in Feet	Suggested Resale
AQ-5	5	\$37.49
AQ-10	10	\$42.49
AQ-15	15	\$47.99
AQ-20	20	\$52.99
AQ-25	25	\$57.99
AQ-30	30	\$62.99
AQ-50	50	\$82.49
AQ-100	100	\$133.99

MasterMike



Pro Co's mainstream 2-conductor, highly durable, 91.5% braided shield mic cables, designed for lead singers with an attitude — tough, reliable, designed for rough long-term use. Its try-and-break-me construction will keep your act running night after night, year after year.

- Black Neutrik connectors, silver contacts
- One tough puppy
- Over 1,000,000 in use all over the world
- 20 year warranty

Model Number	Length in Feet	Suggested Resale
M-5	5	\$23.99
M-10	10	\$28.49
M-15	15	\$31.49
M-20	20	\$34.99
M-25	25	\$37.99
M-30	30	\$42.49
M-50	50	\$55.99
M-100	100	\$92.99

AmeriQuad and MasterMike microphone cables are available with XLR male or female right angle plugs, colored I.D. bands and On/Off switches on the female end. See page 27 for details and pricing.

Microphone Cables

Excellines



Our largest selling microphone cable, using Neutrik's IDC (insulation displacement connection) XLR connectors and Pro Co's time tested 224S (2-conductor, 24 gauge, spiral shield) cable. Quick to assemble using a combination of humans and robots, and very reliable because of the fabulous Neutrik strain relief, Excellines offer decent flexibility, good shielding and an extremely popular price.

- High speed production method reduces costs
- Great for normal boardroom, speaker podium or weekender band use

Model Number	Length in Feet	Suggested Resale
EXM-3	3	\$19.99
EXM-5	5	\$20.49
EXM-10	10	\$22.49
EXM-15	15	\$24.49
EXM-20	20	\$25.99
EXM-25	25	\$28.49
EXM-30	30	\$30.49
EXM-50	50	\$38.49
EXM-100	100	\$59.99



Hi Impedance (Hi-Z) cables

A reliable cable for hooking up Hi-Z microphones to guitar amp inputs or to sound systems with Hi-Z mic inputs.

- Wired pin 2 hot as standard and pin 3 hot is also available
- Uses Neutrik XLR female and ShowSavers 1/4" connectors

- Should not be used in lengths greater than 20 feet to avoid high frequency rolloff
- 10 year warranty

Model Number	Length in Feet	Suggested Resale
EXH-20	20	\$22.99
EXHP3H-20	20	\$22.99



Low Impedance to High Impedance Transformer Cable

The proper way to connect a professional low impedance microphone to a consumer grade high impedance mixer input or guitar amp input is to provide a transformer that converts the low impedance microphone output to high impedance as close to the amp/mixer as possible. This cable has a very clever Neutrik 1/4" transformer plug on one end and a Neutrik XLR female connector on the other to accomplish this important task.

- Excellent transformer for the size (it's too small to take lots of power and saturates [distorts] easily when too much bass is run through it).
- Best used for voice only
- Flexible and durable, needed often in DJ applications
- 10 year warranty

Model Number	Length in Feet	Suggested Resale
EXHT-20	20	\$61.99
EXHT-25	25	\$64.49

StageMASTER



There is always a need for inexpensive products, for starving musicians, civic and religious groups with limited budgets, for price sensitive buyers and for applications in which wear and tear just do not exist.

StageMASTER mic cables are inexpensive, built by our friends at Neutrik in their Chinese plant and we can assure you that these are the best inexpensive mic cables available anywhere.

Model Number	Length in Feet	Suggested Resale
SMM3	3	\$8.99
SMM5	5	\$9.49
SMM10	10	\$11.49
SMM15	15	\$12.99
SMM20	20	\$15.49
SMM25	25	\$17.99
SMM30	30	\$19.49
SMM50	50	\$21.99

Speaker Cables

Fat Max 8 Gauge Speaker Cables



Fat Max makes every other speaker cable look like it's on a diet. The truth of the matter is that to provide proper damping factor and have really tight low end that produces the tonality of your instrument (instead of the tonality of the free air resonance of your speaker) you need lots of copper. Lots of current (volume) needs lots of copper. Fat Max's 8 gauge cable is as much bigger than 12 gauge as 12 gauge is to 16 gauge, 256% bigger in fact. To even make Fat Max work, we had to completely redesign 1/4" and dual banana plug speaker connectors and design unique ways to get Fat Max to fit into a Speakon connector.

- Ultrasonically welded, no whimpy solder connections allowed
- No measurable DC resistance to be found
- Gold contacts on 1/4" and banana plugs
- Tightens low end signal remarkably, even in 3' lengths
- Can be used as welding leads or to tow your boat in a pinch
- Lifetime warranty — any excuse, even abuse

PowerPlus 12 Gauge Speaker Cables



Pro Co's Power Plus speaker cables use specifically designed oxygen-free ShowSavers brand speaker connectors and Pro Co's ArmorFlex jacketed 12 gauge, 65 strand speaker wire, providing the user with the best industry-standard 12 gauge cables available.

- Very flexible, coils/uncoils very easily
- 12 gauge copper-core ShowSavers 1/4" speaker connectors offer an improvement to this type of connector (which really should not be used in speaker applications in the first place)
- Available in 1/4", banana plug and Speakon versions
- 20 year warranty

Excellines 14 Gauge Speaker Cables



No one should be running a live sound system with anything less than 12 gauge wire. Alas, knowledge and cost often prevent this, but running a system with live entertainers with less than 12 gauge wire is just going to lessen the audience's enjoyment of the performance. In the last 20 years the popular gauge has increased from 16 gauge to 14 gauge (the smaller the number, the bigger the wire). As the industry grows more aware of the effect wire gauge has on damping factor, 12 gauge is selling more and more, but for now, 14 gauge is the standard gauge speaker cable sold for portable use.

- ShowSavers brand 1/4" connectors
- Sturdy banana plugs
- Neutrik Speakons
- Large varieties of optional end configurations
- 10 year warranty

Speaker cables are available with 1/4" or Speakon right angle plugs. See page 27 for details and pricing

Speaker Cables

Excellines 16 Gauge Speaker Cables



Pro Co does not recommend the use of 16 gauge speaker cables for live use. Having said that, we sell 50,000 of them a year. Use them in systems with 100-200 watts only, nothing more. Ours are sturdy, well-built cables, using ArmorFlex speaker cable and ShowSavers plugs, Pro Co Banana plugs and Neutrik Speakons. They just need more copper than this for professional jobs.

- Too much resistance for most live applications, making amps work way too hard
- Severe power loss
- Poor damping factor
- 10 year warranty

Speaker cables are available with 1/4" or Speakon right angle plugs. See page 28 for details and pricing

PowerPlus 11 Gauge Speaker Cables (Two Circuits)



Pro Co's 11-4 (11 gauge, 4-conductor) cable was designed to fit into Neutrik NL4FX 4-conductor Speakons, the largest gauge of stranded wire that we could practically "fit" into these wonderful speaker connectors. This allows users to get the maximum impact possible from the improvements these connectors provide the trade.

- New 50 amp Neutrik Speakons
- High strand count, flexible 11 gauge, 4-conductor wire
- 20 year warranty

PowerPlus 13 Gauge Speaker Cables (Four Circuits)



Pro Co's 13-8 (13 gauge, 8-conductor) cable was designed to fit into Neutrik 8-conductor Speakons, the largest gauge of stranded wire that we could practically "fit" into these wonderful speaker connectors. This allows users to get the maximum impact possible from the improvements these connectors provide the trade.

- 30 amp Neutrik Speakon connectors
- High strand count, flexible 13 gauge, 8-conductor wire
- 20 year warranty

Speaker Cables



1/4" Phone Plug to 1/4" Phone Plug

Fat Max 8 AWG cable - 1/4" to 1/4" phone plugs Pro Co ArmorFlex jacketed 11 gauge 4-conductor portable speaker wire, twinned to create the industry's first 8 gauge 2-conductor assembly, ultrasonically welded to custom-designed ShowSavers Megafoot black-handled gold-finished 1/4" phone plugs on each end.	Model Number	Length in Feet	Suggested Resale
	FM-3	3	\$76.99
	FM-6	6	\$81.49
	FM-10	10	\$83.99
	FM-25	25	\$120.49
	FM-50	50	\$183.49
Power Plus 12 AWG cable - 1/4" to 1/4" phone plugs Pro Co ArmorFlex jacketed 12 gauge 2-conductor portable speaker wire with two G & H Industries ShowSavers 1/4" speaker plugs.	S12-3	3	\$23.49
	S12-6	6	\$25.99
	S12-10	10	\$28.49
	S12-25	25	\$41.49
	S12-50	50	\$61.99
	S12-100	100	\$104.99
Excellines 14 AWG cable - 1/4" to 1/4" phone plugs Pro Co ArmorFlex jacketed 14 gauge 2-conductor portable speaker wire with two G & H Industries ShowSavers 1/4" plugs.	S14-3	3	\$16.99
	S14-6	6	\$18.99
	S14-10	10	\$20.49
	S14-25	25	\$29.49
	S14-50	50	\$42.99
Excellines 16 AWG cable - 1/4" to 1/4" phone plugs Pro Co ArmorFlex jacketed 16 gauge 2-conductor portable speaker wire with two G & H Industries ShowSavers 1/4" plugs.	S16-3	3	\$16.99
	S16-6	6	\$17.49
	S16-10	10	\$18.99
	S16-25	25	\$23.49
	S16-50	50	\$32.49



1/4" Phone Plug to Dual Banana Plug

Fat Max 8 AWG - 1/4" phone plug to dual banana plug Pro Co ArmorFlex jacketed 11 gauge 4-conductor speaker wire, twinned to create the industry's first 8 gauge 2-conductor assembly, ultrasonically welded to one ShowSavers Megafoot black-handled gold-finished 1/4" phone plug and ultrasonically welded to two ring terminals which are then attached to a G & H Industries THE BOSS™ dual banana plug.	Model Number	Length in Feet	Suggested Resale
	FMBQ-3	3	\$61.99
	FMBQ-6	6	\$70.99
	FMBQ-10	10	\$74.99
	FMBQ-25	25	\$111.99
	FMBQ-50	50	\$173.99
Power Plus 12 AWG cable - 1/4" phone plug to dual banana plug Pro Co ArmorFlex jacketed 12 gauge 2-conductor portable speaker wire with one ShowSavers 1/4" speaker plug to one G & H Industries THE BOSS dual banana plug.	S12BQ-10	10	\$30.49
	S12BQ-25	25	\$42.99
	S12BQ-50	50	\$63.49
	S12BQ-100	100	\$105.99
Excellines 14 AWG cable - 1/4" phone plug to dual banana plug Pro Co ArmorFlex jacketed 14 gauge 2-conductor portable speaker wire with one ShowSavers 1/4" plug to one dual banana plug.	S14BQ-3	3	\$18.49
	S14BQ-6	6	\$19.49
	S14BQ-10	10	\$21.49
	S14BQ-25	25	\$29.99
	S14BQ-50	50	\$43.99
Excellines 16 AWG cable - 1/4" phone plug to dual banana plug Pro Co ArmorFlex jacketed 16 gauge 2-conductor portable speaker wire with one ShowSavers 1/4" plug to one dual banana plug.	S16BQ-3	3	\$16.99
	S16BQ-6	6	\$17.49
	S16BQ-10	10	\$18.99
	S16BQ-25	25	\$24.49
	S16BQ-50	50	\$33.49

Speaker Cables



Dual Banana Plug to Dual Banana Plug

	Model Number	Length in Feet	Suggested Resale
Fat Max 8 AWG - Dual banana plug to dual banana plug Pro Co ArmorFlex jacketed 11 gauge 4-conductor speaker wire, twinned to create the industry's first 8 gauge 2-conductor assembly, each end ultrasonically welded to two ring terminals which are then attached to a G & H Industries gold THE BOSS dual banana plug on each end.	FMBB-3	3	\$55.99
	FMBB-6	6	\$60.99
	FMBB-10	10	\$63.49
	FMBB-25	25	\$93.49
	FMBB-50	50	\$157.49
Power Plus 12 AWG cable - Dual banana plug to dual banana plug Pro Co ArmorFlex jacketed 12 gauge 2-conductor portable speaker wire with two G & H Industries THE BOSS dual banana plugs.	S12BB-10	10	\$31.99
	S12BB-25	25	\$43.99
	S12BB-50	50	\$64.99
	S12BB-100	100	\$106.49
Excellines 14 AWG cable - Dual banana plug to dual banana plug Pro Co ArmorFlex jacketed 14 gauge 2-conductor portable speaker wire with two dual banana plugs.	S14BB-3	3	\$17.99
	S14BB-6	6	\$18.49
	S14BB-10	10	\$21.49
	S14BB-25	25	\$29.99
	S14BB-50	50	\$43.49
Excellines 16 AWG cable - Dual banana plug to dual banana plug Pro Co ArmorFlex jacketed 16 gauge 2-conductor portable speaker wire with two dual banana plugs.	S16BB-10	10	\$18.99
	S16BB-25	25	\$23.99
	S16BB-50	50	\$32.49



1/4" Phone Plug to 2-conductor Speakon

	Model Number	Length in Feet	Suggested Resale
Fat Max 8 AWG - 1/4" phone plug to 4-conductor Speakon (NL4FX) Pro Co 11 gauge 4-conductor speaker wire, twinned to create the industry's first 8 gauge 2-conductor assembly, ultrasonically welded to one ShowSavers Megafoot 1/4" gold phone plug and on the other end two 11 gauge conductors are crimped together ending up with a single 8 gauge circuit, 1+ and 1- on the Speakon. The leads are then inserted into the terminals on the NL4FX and crimped down using the Speakon screws provided.	FMNQ-3	3	\$66.99
	FMNQ-6	6	\$71.99
	FMNQ-10	10	\$78.99
	FMNQ-25	25	\$118.49
	FMNQ-50	50	\$165.99
Power Plus 12 AWG cable - 1/4" phone plug to 2-conductor Speakon (NL2FC) Pro Co ArmorFlex jacketed 12 gauge 2-conductor portable speaker wire with one G & H Industries ShowSavers 1/4" speaker plug to one Neutrik NL2FC single circuit Speakon 2-conductor plug.	S12NQ-10	10	\$31.99
	S12NQ-25	25	\$44.99
	S12NQ-50	50	\$64.99
	S12NQ-100	100	\$106.49
Excellines 14 AWG cable - 1/4" phone plug to 2-conductor Speakon (NL2FC) Pro Co ArmorFlex jacketed 14 gauge 2-conductor portable speaker wire with one G & H Industries ShowSavers 1/4" plug to one Neutrik NL2FC single circuit Speakon 2-conductor plug.	S14NQ-3	3	\$21.99
	S14NQ-6	6	\$22.99
	S14NQ-10	10	\$25.49
	S14NQ-25	25	\$33.49
	S14NQ-50	50	\$47.49
Excellines 16 AWG cable - 1/4" phone plug to 2-conductor Speakon (NL2FC) Pro Co ArmorFlex jacketed 16 gauge 2-conductor portable speaker wire with one G & H Industries ShowSavers 1/4" plug to one Neutrik NL2FC single circuit Speakon 2-conductor plug.	S16NQ-3	3	\$20.49
	S16NQ-6	6	\$20.99
	S16NQ-10	10	\$21.99
	S16NQ-25	25	\$27.99
	S16NQ-50	50	\$36.99

Speaker Cables



Dual Banana Plug to Speakon

	Model Number	Length in Feet	Suggested Resale
Fat Max 8 AWG cable - Dual banana plug to 2-conductor Speakon (NL4FX) Pro Co 11 gauge 4-conductor speaker wire, twinned to create the industry's first 8 gauge 2-conductor assembly, ultrasonically welded then attached to a G & H Industries gold THE BOSS dual banana plug. On the other end two 11 gauge conductors are crimped together into an 8 gauge lead (ending up with a single circuit, 1+ and 1- on the Speakon). The leads are then inserted into the terminals on the NL4FX and crimped down using the Speakon screws provided.	FMBN-3	3	\$60.49
	FMBN-6	6	\$62.99
	FMBN-10	10	\$65.49
	FMBN-25	25	\$101.99
	FMBN-50	50	\$157.49
Power Plus 12 AWG cable - Dual banana plug to 2-conductor Speakon (NL2FC) Pro Co ArmorFlex jacketed 12 gauge portable 2-conductor speaker wire with one G & H Industries THE BOSS dual banana plug and one Neutrik Speakon (NL2FC)	S12BN-10	10	\$33.49
	S12BN-25	25	\$45.99
	S12BN-50	50	\$67.49
	S12BN-100	100	\$97.99
Excellines 14 AWG cable - Dual banana plug to 2-conductor Speakon (NL2FC) Pro Co ArmorFlex jacketed 14 gauge 2-conductor portable speaker wire with one dual banana plug and one Neutrik Speakon (NL2FC)	S14BN-10	10	\$24.99
	S14BN-25	25	\$33.49
	S14BN-50	50	\$47.49
Excellines 16 AWG cable - Dual banana plug to 2-conductor Speakon (NL2FC) Pro Co ArmorFlex jacketed 16 gauge 2-conductor portable speaker wire with one dual banana plug and one Neutrik Speakon (NL2FC)	S16BN-10	10	\$21.99
	S16BN-25	25	\$27.49
	S16BN-50	50	\$36.99



Speakon to Speakon

	Model Number	Length in Feet	Suggested Resale
Fat Max 8 AWG - Speakon to Speakon (NL4FXs) Pro Co 11 gauge 4-conductor speaker wire, twinned to create the industry's first 8 gauge 2-conductor assembly. Two 11 gauge conductors are crimped together into an 8 gauge lead (ending up with a single circuit, 1+ and 1- on the Speakon). The leads are then inserted into the terminals on the NL4FXs and crimped down using the Speakon screws provided.	FMNN-3	3	\$59.99
	FMNN-6	6	\$64.99
	FMNN-10	10	\$83.99
	FMNN-25	25	\$104.99
	FMNN-50	50	\$161.49
Power Plus 12 AWG cable - Speakon to Speakon (NL2FCs) Pro Co ArmorFlex jacketed 12 gauge 2-conductor portable speaker wire with a Neutrik Speakon (NL2FC) on each end.	S12NN-10	10	\$34.99
	S12NN-25	25	\$47.49
	S12NN-50	50	\$68.49
	S12NN-100	100	\$109.49
Excellines 14 AWG cable - Speakon to Speakon (NL2FCs) Pro Co ArmorFlex jacketed 14 gauge 2-conductor portable speaker wire with a Neutrik Speakon (NL2FC) on each end.	S14NN-3	3	\$24.99
	S14NN-6	6	\$26.99
	S14NN-10	10	\$28.99
	S14NN-25	25	\$38.99
	S14NN-50	50	\$51.99
Excellines 16 AWG cable - Speakon to Speakon (NL2FCs) Pro Co ArmorFlex jacketed 16 gauge 2-conductor portable speaker wire with a Neutrik Speakon (NL2FC) on each end.	S16NN-3	3	\$23.49
	S16NN-6	6	\$24.99
	S16NN-10	10	\$25.99
	S16NN-25	25	\$31.49
	S16NN-50	50	\$39.99

Multiple Circuit Speaker Cables

Two Circuit

	Model Number	Length in Feet	Suggested Resale
Power Plus 11 AWG cable - One 4-conductor Speakon (NL4FX) to two ShowSaver 1/4" phone plugs (two 11 gauge circuits). Pro Co ArmorFlex jacketed 11 gauge 4-conductor speaker wire with two ShowSavers 1/4" phone plugs on one end and one Speakon (NL4FX) on the other	S114NQ-6	6	\$61.99
	S114NQ-10	10	\$68.49
	S114NQ-25	25	\$110.49
	S114NQ-50	50	\$160.49
	S114NQ-100	100	\$282.49
Power Plus 11 AWG cable - Two G & H Industries THE BOSS dual banana plugs to one Speakon NL4FX (two 11 gauge circuits). Pro Co ArmorFlex jacketed 11 gauge 4-conductor speaker wire with two THE BOSS dual banana plugs one end and one 4-conductor Speakon (NL4FX) on the other (NL4FX)	S114BN-6	6	\$55.99
	S114BN-10	10	\$65.49
	S114BN-25	25	\$113.49
	S114BN-50	50	\$177.49
	S114BN-100	100	\$305.49
Power Plus 11 AWG cable - 4-conductor Speakon to Speakon (NL4FXs) (two 11 gauge circuits). Pro Co ArmorFlex jacketed 11 gauge 4-conductor speaker wire with a Neutrik Speakon NL4FX on each end.	S114NN-6	6	\$61.99
	S114NN-10	10	\$72.49
	S114NN-25	25	\$110.49
	S114NN-50	50	\$174.99
	S114NN-100	100	\$302.99

Four Circuit

Power Plus 13 AWG cable - One 8-conductor Speakon (NL8FC) on each end. Pro Co ArmorFlex jacketed 13 gauge 8-conductor speaker wire with a	S138NN-10	10	\$116.49
	S138NN-25	25	\$157.99
	S138NN-50	50	\$203.99
	S138NN-100	100	\$356.99

Adapter Speaker Cables



16 AWG cables Banana to 1/4" female in line jack Excellines 16 AWG two conductor portable speaker wire with dual banana plug to 1/4" female phone jack.	Model Number	Length in Feet	Suggested Resale
	S16BQF-1	1	\$17.99



16 AWG cables 1/4" female in line jack to a Speakon NL2FC Excellines 16 AWG two conductor portable speaker wire with Speakon (NL4FX) wired single circuit (circuit 1+, 1-) female to 1/4" female phone jack.	Model Number	Length in Feet	Suggested Resale
	S16NQF-1	1	\$21.49

StageMASTER



StageMASTER There is always a need for inexpensive products, for starving musicians, civic and religious groups with limited budgets, for price sensitive buyers and for applications in which wear and tear just do not exist. StageMASTER speaker cables are inexpensive, built using 100% American parts and 100% American wire (Oops! Banana plugs used on these cables are made in China). 16 gauge cable is used here to keep costs low.	Model Number	Length in Feet	Suggested Resale
	SR16-5	5	\$13.49
	SR16-10	10	\$14.49
	SR16-25	25	\$18.49
	SR16-50	50	\$23.99
	SR16BQ-25	25	\$17.99
	SR16BQ-50	50	\$23.49

Analog Patch Cables



PQR shown above.

Single Unbalanced Patch (P) Cables

Pro Co patch cables were designed to connect unbalanced signals in today's sound and recording systems. They are constructed using Pro Co 120SM wire and ShowSavers 1/4" plugs and/or Pro Co HD RCA connectors.

- QR (1/4" to RCA) and RR (RCA to RCA) configurations to connect consumer gear and semi-pro gear together.
- Using Pro Co 120SM ArmorFlex single conductor jacketed wire
- 10 year warranty

PQR Pro Co 120SM wire, single conductor spiral shield wire with a ShowSavers 1/4" plug on one end and a Pro Co HD RCA phono plug on the other.

Model Number	Length in Feet	Suggested Resale
PQR-3	3	\$16.99
PQR-5	5	\$17.49
PQR-10	10	\$18.49
PQR-20	20	\$21.99



PRR Pro Co 120SM wire, single conductor spiral shield wire with a Pro Co HD RCA phono plug on each end.

Model Number	Length in Feet	Suggested Resale
PRR-3	3	\$15.49
PRR-5	5	\$15.99
PRR-10	10	\$17.49
PRR-20	20	\$20.99



DK shown above

Dual Unbalanced Keyboard (DK) Patch Cables

Dual Keyboard cables were designed to connect today's stereo keyboard outputs to mixers for stage and recording use. They are constructed of two single conductor cables "twinned" together for ease of use and transportation and are offered with ShowSavers 1/4" phone plugs or Pro Co HD RCA male ends to accommodate a wide variety of input and outputs.

- QQ (1/4" to 1/4") configurations, RR (RCA to RCA) configurations and QR (1/4" to RCA) configurations, to connect consumer gear (RCA) to semi-pro (1/4") gear
- Twinned single-conductor ArmorFlex jacketed spiral shield wire (Pro Co 2120SM)
- ShowSavers brand 1/4" phone plugs and Pro Co HD RCA connectors
- 10 year warranty

DK Pro Co 2120SM 2-conductor patch cable with a spiral shield and two ShowSavers 1/4" connectors on each end

Model Number	Length in Feet	Suggested Resale
DK-3	3	\$26.99
DK-5	5	\$28.99
DK-10	10	\$32.49
DK-20	20	\$38.99



DKQR Pro Co 2120SM 2-conductor patch cable with a spiral shield and two ShowSavers 1/4" phone plugs on one end to two Pro Co HD RCA phono plugs on the other

Model Number	Length in Feet	Suggested Resale
DKQR-3	3	\$26.49
DKQR-5	5	\$27.49
DKQR-10	10	\$30.49
DKQR-20	20	\$37.49



DKRR Pro Co 2120SM 2-conductor patch cable with a spiral shield with two Pro CO HD RCA plugs on each end.

Model Number	Length in Feet	Suggested Resale
DKRR-3	3	\$24.49
DKRR-5	5	\$25.49
DKRR-10	10	\$28.49
DKRR-20	20	\$35.49

Analog Patch Cables



Did you really want to spend the time to wire this all by yourself? That's what we thought!

Rac-Kables (RK)

A practical solution for wiring racks! Pre-wired on one end with a variety of connectors and pre-cut to 10', 20' or 30' lengths. Just plug them in and run the blunt end to the correct length, cut and terminate. This unique system reduces rack wiring time substantially and costs almost nothing to keep on the shelf, ready to wire.

- All assemblies use Pro Co AC1, a CL2 rated, and 100% foil shielded cable (like Belden 8451 or West Penn 291), an excellent pull cable
- Connectors are ShowSavers T/S and T/R/Ss, Neutrik XLRs and Pro Co HD RCAs
- Cuts time to wire audio racks in half.



RKXM Pro Co AC1 wire and Neutrik XLR male connector



RKXF Pro Co AC1 wire and Neutrik XLR female connector



RKQ Pro Co AC1 wire and ShowSavers 1/4" T/S plug



RKBQ Pro Co AC1 wire and ShowSavers 1/4" T/R/S plug



RKR Pro Co AC1 wire and Pro Co HD RCA phono plug

Model Number	Length in Feet	Suggested Resale
RKXM-10	10	\$12.49
RKXM-20	20	\$14.99
RKXM-30	30	\$17.49
RKXF-10	10	\$12.49
RKXF-20	20	\$14.99
RKXF-30	30	\$17.49
RKQ-10	10	\$12.49
RKQ-20	20	\$14.99
RKQ-30	30	\$17.49
RKBQ-10	10	\$12.49
RKBQ-20	20	\$14.99
RKBQ-30	30	\$17.49
RKR-10	10	\$12.49
RKR-20	20	\$14.99
RKR-30	30	\$17.49



PJ shown above

PJ (Phone Jack) Cables

The phone company invented the phone plug in 1885, a long time ago. They are built differently than the 1/4" connectors we are used to seeing in audio, but perform exactly the same function in military type jackfields. These 1/4" tip/ring/sleeve

(T/R/S) mil spec cables use Neutrik's especially designed connectors and Pro Co's 424BK wire to make these sturdy, long-life assemblies. These connectors are typically used in theatres and Broadway shows and are not commonly used in the portable world.

- Sold in 1/4" to 1/4" mic spec cables
- Sold in 1/4" mil spec to XLR male or female connectors

PJ Using Pro Co's 424BK quad mic cable with Kevlar in the core and one Neutrik mil spec 1/4" connector on each end.

Model Number	Length in Feet	Suggested Resale
PJ-2	2	\$39.99
PJ-3	3	\$40.49



PJXF Using Pro Co's 424BK quad mic cable with Kevlar in the core and one Neutrik mil spec 1/4" connector on one end and one Neutrik XLR female connector on the other.

PJXF-2	2	\$39.99
PJXF-3	3	\$40.99



PJXM Using Pro Co's 424BK quad mic cable with Kevlar in the core and one Neutrik mil spec 1/4" on one end and one Neutrik XLR male connector on the other.

PJXM-2	2	\$39.49
PJXM-3	3	\$40.99



PJBQ Using Pro Co's 424BK quad mic cable with Kevlar in the core and one Neutrik mil spec 1/4" on one end and one ShowSavers 1/4" T/R/S plug on the other.

PJBQ-2	2	\$39.99
PJBQ-3	3	\$40.99

Analog Patch Cables



TT shown above

TT (Tiny Telephone or "Bantam" Plugs) Cables

Most professional recording studios use TT T/R/S patchbays because they offer 96 patch points in a single-space 19" rack panel. Our TT cables are ShowSavers Bantam plugs and Pro Co miniature wire to perform this important patching function.

- Use for high density needs where rack space is at a premium
- ShowSavers brand TT plugs are used in our assemblies
- Available in TT to TT versions, and also TT to XLR male and female connectors or 1/4" T/R/S phone plugs.
- 20 year warranty

	Model Number	Length in Feet	Suggested Resale
TT Using Pro Co 2245M miniature mic cable with spiral shield assembled to a ShowSavers TT plug on each end.	TT-2	2	\$32.49
	TT-3	3	\$33.49



TTXF Using Pro Co 2245M miniature mic cable with spiral shield assembled to a ShowSavers TT plug on one end and a Neutrik XLR female on the other.

TTXF-2	2	\$32.49
TTXF-3	3	\$33.49



TTXM Using Pro Co 2245M miniature mic cable with spiral shield assembled to a ShowSavers TT plug on one end and a Neutrik XLR male on the other.

TTXM-2	2	\$32.49
TTXM-3	3	\$33.49



TTBQ Using Pro Co 2245M miniature mic cable with spiral shield assembled to a ShowSavers TT plug on one end and a ShowSavers 1/4" T/R/S connector on the other.

TTBQ-2	2	\$32.49
TTBQ-3	3	\$33.49



"Y" Cords

Pro Co makes standard "Y" cords, the most basic of which are constructed with one 1/4" phone plug (male or female) to two 1/4" phone plugs (male or female). The same concept can be built using male and female XLR connectors and RCA phono plugs.

- ShowSavers plugs, Neutrik XLRs and Pro Co HD RCA connectors are used.
- Pro Co 21205M or 2245M wire is typically used.

	Model Number	Length in Feet	Suggested Resale
YGQF2Q Pro Co 2120 SM patch cable with spiral shield with a 1/4" female inline phone jack to two ShowSavers phone plugs	YGQF2Q-1	1	\$29.99



YGQ2QF Pro Co 21205M patch cable with spiral shield with a ShowSavers 1/4" phone plug to two 1/4" female inline phone jacks.

YGQ2QF-1	1	\$36.49
----------	---	---------



YMXF2XM Pro Co 2245M patch cable with spiral shield with a Neutrik XLR female to two Neutrik XLR males

YMXF2XM-1	1	\$29.49
-----------	---	---------



YMXM2XF Pro Co 2245M patch cable with spiral shield with a Neutrik XLR male to two Neutrik XLR females

YMXM2XF-1	1	\$29.49
-----------	---	---------



YGQ2R Pro Co 21205M patch cable with spiral shield with a ShowSavers 1/4" phone plug on one end to two Pro Co HD RCA phono plugs on the other.

YGQ2R-3	3	\$22.49
YGQ2R-5	5	\$24.49
YGQ2R-10	10	\$27.49

Analog Patch Cables

Insert Patch Cables

Another type of “Y” cord, insert patch cables allow mixing consoles to send/return signals to an outboard effect processor, say a digital reverb. Typically the I/O (inputs/outputs) start as a T/R/S 1/4” output jack on the mixing console. Sends typically go through the tip and returns through the ring and there is a common ground, the sleeve. The cable needs to be wired properly and each end needs to be identified for the user, to ensure proper hook-ups. Obviously, a wide variety of insert patch cables is necessary to accommodate the wide variety of processors available.

- T/R/S ShowSavers plugs, Neutrik XLRs and Pro Co HD RCA connectors
- Pro Co 2120SM wire is typically used here
- 10 year warranty



IPBQ2R Pro Co 2120 SM patch cable with spiral shield with a ShowSavers 1/4” T/R/S connector on one end to two Pro Co HD RCA phono connectors on the other.

Model Number	Length in Feet	Suggested Resale
IPBQ2R-3	3	\$25.49
IPBQ2R-5	5	\$26.99
IPBQ2R-10	10	\$30.49
IPBQ2R-20	20	\$38.49



IPBQ2Q Pro Co 2120SM patch cable with spiral shield with a ShowSavers 1/4” T/R/S connector on one end to two ShowSaver T/S phone plugs on the other.

IPBQ2Q-3	3	\$26.99
IPBQ2Q-5	5	\$28.49
IPBQ2Q-10	10	\$32.49
IPBQ2Q-20	20	\$39.49



IPRBQXFXM Pro Co 2120SM patch cable with spiral shield with a ShowSavers T/R/S male connector to a Neutrik female (send) and a Neutrik male (return). Wired ring on the T/R/S to pin 2 on the female XLR and tip on the T/R/S to pin 2 on the male XLR. Pins 1 and 3 are bridged on the XLRs. These are rarely used today only when the processor uses unbalanced XLR I/Os.

IPRBQXFXM-3	3	\$33.99
IPRBQXFXM-5	5	\$35.99
IPRBQXFXM-10	10	\$37.99
IPRBQXFXM-20	20	\$47.49



IPTBQXFXM Pro Co 2120SM patch cable with spiral shield with a ShowSavers T/R/S male connector to a Neutrik female (send) and a Neutrik male (return). Wired tip on the T/R/S to pin 2 on the female XLR and ring on the T/R/S to pin 2 on the male LXR. Pins 1 and 3 are bridged on the XLRs. These are rarely used today only when the processor uses unbalanced XLR I/Os.

IPTBQXFXM-3	3	\$33.99
IPTBQXFXM-5	5	\$25.99
IPTBQXFXM-10	10	\$37.99
IPTBQXFXM-20	20	\$47.49











NOTE: many custom configurations of Y-cables, both balanced and unbalanced are available. Please check with the factory for pricing and specifications. Insert snakes can be found on page 14.

Analog Patch Cables

Ameriquad Balanced Patch Cables

Professional balanced patch cables using custom ShowSavers and Neutrik XLR plugs, each with gold contacts and Pro Co's 424BK quad mic cable for the ultimate in looks and performance for professional installations. Balanced line cables are assembled using T/R/S connectors in combination with either XLR male or female connectors. They are needed in the trade because mixer manufacturers use either T/R/S or XLRs depending on real estate or price issues.

- All black housings for a professional look
- Pro Co 424BK 4-conductor bi-wire technology assemblies
- ShowSavers 1/4" connectors and Neutrik XLRs are used
- 20 year warranty

		Model Suggested Number Resale	Length in Feet
	AQBP Pro Co's 424BK ArmorFlex jacketed 4-conductor cable with 96% braided shield to custom black-handled ShowSavers T/R/S phone plugs on each end.	AQBP-3 \$36.99	3
	AQBPBQXF Pro Co's 424BK ArmorFlex jacketed 4-conductor cable with 96% braided shield to a custom black-handled ShowSavers T/R/S plug on one end and a Neutrik female XLR on the other.	AQBPBQXF-3 \$39.49	3
	AQBPBQXF Pro Co's 424BK ArmorFlex jacketed 4-conductor cable with 96% braided shield to a custom black-handled ShowSavers T/R/S plug on one end and a Neutrik female XLR on the other.	AQBPBQXF-5 \$44.49	5
	AQBPBQXF Pro Co's 424BK ArmorFlex jacketed 4-conductor cable with 96% braided shield to a custom black-handled ShowSavers T/R/S plug on one end and a Neutrik female XLR on the other.	AQBPBQXF-10 \$55.49	10
	AQBPBQXF Pro Co's 424BK ArmorFlex jacketed 4-conductor cable with 96% braided shield to a custom black-handled ShowSavers T/R/S plug on one end and a Neutrik female XLR on the other.	AQBPBQXF-20 \$55.49	20
	AQBPBQXF Pro Co's 424BK ArmorFlex jacketed 4-conductor cable with 96% braided shield to a custom black-handled ShowSavers T/R/S plug on one end and a Neutrik female XLR on the other.	AQBPBQXF-3 \$37.99	3
	AQBPBQXF Pro Co's 424BK ArmorFlex jacketed 4-conductor cable with 96% braided shield to a custom black-handled ShowSavers T/R/S plug on one end and a Neutrik female XLR on the other.	AQBPBQXF-5 \$39.99	5
	AQBPBQXF Pro Co's 424BK ArmorFlex jacketed 4-conductor cable with 96% braided shield to a custom black-handled ShowSavers T/R/S plug on one end and a Neutrik female XLR on the other.	AQBPBQXF-10 \$45.49	10
	AQBPBQXF Pro Co's 424BK ArmorFlex jacketed 4-conductor cable with 96% braided shield to a custom black-handled ShowSavers T/R/S plug on one end and a Neutrik female XLR on the other.	AQBPBQXF-20 \$55.99	20
	AQBPBQBF Pro Co's 424BK ArmorFlex jacketed 4-conductor cable with 96% braided shield to a custom black-handled ShowSavers T/R/S plug on one end and a Neutrik T/R/S female inline jack on the other.	AQBPBQBF-3 \$55.99	3

Several connector options, such as right angle plugs and gold connectors are available. See page 27 for details and pricing.

Analog Patch Cables

Balanced Patch Cords

Balanced lines are terminated using XLR connectors, T/R/S 1/4" connectors and combinations of the two connector styles. Balanced patch cables are needed to offer options for hooking XLR outputs to T/R/S inputs, and so on. Obviously, a variety of options is necessary, do to the whims of the manufacturers. The basic balanced patch cables are included herein for your convenience. We make lots of different ones on a custom basis.

- Neutrik XLRs
- G & H ShowSavers
- Pro Co 224S wire
- 5 year warranty



BP Pro Co's 224S Armorflex jacketed 2-conductor cable with spiral shield with ShowSavers T/R/S phone plugs on each end.

Model Number	Length in Feet	Suggested Resale
BP-3	3	\$28.99
BP-5	5	\$26.49
BP-10	10	\$31.99
BP-20	20	\$35.49



BPBQXF Pro Co's 224S Armorflex jacketed 2-conductor cable with spiral shield with a ShowSavers T/R/S plug on one end and a Neutrik XLR female on the other.

BPBQXF-3	3	\$26.49
BPBQXF-5	5	\$27.49
BPBQXF-10	10	\$28.49
BPBQXF-20	20	\$33.49



BPBQXM Pro Co's 224S Armorflex jacketed 2-conductor cable with spiral shield with a ShowSavers T/R/S plug on one end and a Neutrik XLR male on the other.

BPBQXM-3	3	\$26.49
BPBQXM-5	5	\$26.99
BPBQXM-10	10	\$24.99
BPBQXM-20	20	\$32.99



BPBQBQF Pro Co's 224S Armorflex jacketed 2-conductor cable with spiral shield with a ShowSavers T/R/S plug on one end and a female inline T/R/S jack on the other.

BPBQBQF-3	3	\$35.49
BPBQBQF-5	5	\$31.49
BPBQBQF-10	10	\$37.49
BPBQBQF-20	20	\$42.49

Several connector options, such as right angle plugs and gold connectors are available. See page 27 for details and pricing.



Camcorder Cables

Camcorder cables allow you to connect your camcorder to your sound system's mixing console either to send a signal to the console or receive from it.

- Pro Co wire
- Mono mini plug to XLR female or male 3-pin connector, unbalanced
- 5 year warranty

Model Number	Length in Feet	Suggested Resale	
SHMXF Wire wired mono mini to Neutrik XLR female connector.	SHMXF-5	5	\$19.99
	SHMXF-10	10	\$21.99
	SHMXF-20	20	\$24.99
SHMXM Wire wired mono mini to Neutrik XLR male connector.	SHMXM-5	5	\$19.99
	SHMXM-10	10	\$21.99
	SHMXM-20	20	\$24.99

Analog Patch Cables



Sound Card Cables

Sound card cables allow you to connect your computer's sound card or a minidisk recorder to patchbays, mixers or powered monitors

- We use an excellent MINI (1/8" T/R/S, 3.5 mm) plug, ShowSavers 1/4" connectors and Pro Co HD RCAs
- Pro Co AC2 wire
- Wide variety of lengths
- 5 year warranty

IPMB2R From soundcards or minidisk recorder outputs to inputs on your stereo. Mini balanced to two RCAs or powered monitors.

Model Number	Length in Feet	Suggested Resale
IPMB2R-3	3	\$31.99
IPMB2R-5	5	\$32.99
IPMB2R-10	10	\$38.99
IPMB2R-20	20	\$40.99

IPMB2Q From soundcards or minidisk recorder outputs to patchbays, mixers or powered monitors. Mini balanced to two 1/4" T/S.

IPMB2Q-3	3	\$28.99
IPMB2Q-5	5	\$30.49
IPMB2Q-10	10	\$33.99
IPMB2Q-20	20	\$39.49

IPMB2XM From soundcards or minidisk recorders to mixer or dat machine inputs. Mini balanced to two XLR males.

IPMB2XM-3	3	\$33.49
IPMB2XM-5	5	\$34.49
IPMB2XM-10	10	\$36.99
IPMB2XM-20	20	\$42.49

IPMB2XF From mixer or dat machine outputs to soundcards or minidisk inputs. Mini balanced to two XLR females.

IPMB2XF-3	3	\$33.99
IPMB2XF-5	5	\$34.99
IPMB2XF-10	10	\$37.49
IPMB2XF-20	20	\$42.99



RG6BNC

Video Cables

Pro Co video cables will start with modest offerings and grow as we are presented with the cables the market really wants us to build. We are already heavily involved in video panel connectors with our Plateworks product line. The following are our first two video cable products.

High-speed **1649A (RG6)** Belden cable and Neutrik rear twist NBNC75 75Ω connectors for wider bandwidth

Model Number	Length in Feet	Suggested Resale
RG6BNC- 3	3	\$32.49
RG6BNC- 5	5	\$34.99
RG6BNC-10	10	\$39.99
RG6BNC-20	20	\$47.99

Standard **1505A (RG59U)** (31-71008-1RFX) Belden cable and Amphenol 75Ω BNC connectors for standard transmission speeds.

RG59UBNC - 3	3	\$33.49
RG59UBNC- 5	5	\$35.49
RG59UBNC-10	10	\$41.99
RG59UBNC-20	20	\$52.99



RG59UBNC

We will gladly build any length of any of these cables, as well as any other video cable constructions that you need. Call the factory for details and a price.

Digital Patch Cables



MIDI (Musical Instrument Digital Interface) Cables

MIDI, designed about 1983-84 allows digital equipment to “talk” to each other in a non-analog environment. The standard uses as 5-pin DIN plug but the circuitry uses three of the terminals. Occasionally manufacturers of various gear will use the other two terminals for time code.

- Solid-shell DIN connectors only (split shells break too easily)
- Pro Co’s 424F wire (four, 24 gauge conductors, 100% foil shield)
- All five pins connected
- 5 year warranty

Model Number	Length in Feet	Suggested Resale
MIDI-3	3	\$15.99
MIDI-5	5	\$16.49
MIDI-10	10	\$18.49
MIDI-15	15	\$20.49
MIDI-20	20	\$22.49
MIDI-25	25	\$24.49
MIDI-50	50	\$34.99



S/P DIF (Sony/Philips Digital Interface Format)

Basically S/P DIF is a 75Ω version of an RCA to RCA cable, with a tightened tolerance for keeping the 75Ω impedance consistent foot to foot along the wire. The cable is used to hook up consumer grade digital products, Walkman’s and MP3 players.

- Gold plated RCA heavy duty connectors
- Pro Co’s 125BD wire (one conductor, 25 gauge, braided shield, digital)

Model Number	Length in Feet	Suggested Resale
SPD-1	1	\$22.99
SPD-2	2	\$25.49
SPD-3	3	\$25.99
SPD-5	5	\$27.49
SPD-10	10	\$31.49
SPD-15	15	\$34.99
SPD-20	20	\$38.99
SPD-25	25	\$42.99
SPD-30	30	\$46.99



AES/EBU (Audio Engineering Society/European Broadcast)

A cable that looks exactly like a standard low impedance microphone cable (our AES cable is blue in color so users can tell the difference between their digital and analog cables on stage). The connectors are Neutrik digital XLR connectors and the wire is Pro Co’s 222BD (two conductors, 22 gauge, braided shield, digital). The wire’s impedance is 110Ω to meet the specification.

- Gold plated XLR 110Ω Neutrik connectors
- Pro Co’s 222BD 110Ω digital cable
- 10 year warranty

Model Number	Length in Feet	Suggested Resale
AES-3	3	\$33.49
AES-5	5	\$34.99
AES-10	10	\$38.99
AES-15	15	\$42.99
AES-20	20	\$46.99
AES-25	25	\$50.99
AES-30	30	\$54.99
AES-50	50	\$74.99
AES-100	100	\$111.49



DMX Lighting Control Cable

Not really an audio cable, but a 5-conductor cable used to transmit digital control signals from DMX brand lighting mixing consoles to the various lights in the system. The original spec called out by the manufacture was for a 5-pin XLR connector. Since the control circuit only uses three of the five pins, many people use standard 3-pin microphone cables where they can to save costs.

- Standard 5-pin Neutrik XLR connectors
- 424BK wire

Model Number	Length in Feet	Suggested Resale
DMX-3	3	\$47.99
DMX-5	5	\$50.49
DMX-10	10	\$55.49
DMX-15	15	\$60.49
DMX-20	20	\$69.49
DMX-25	25	\$70.49
DMX-50	50	\$95.49
DMX-100	100	\$145.99

Electrical Extension Cords



E-Cords™ BRAND

E-Cord brand of electrical extension cords

The first extension cords especially designed for the entertainment industry. E-Cords are an extremely durable, yet flexible cord line in a variety of lengths and gauges for different applications. E-Cords are solid black, for easy concealment on stage and are available in 12, 14 and 16 gauge.

- three end configurations:
 - standard
 - power block 3-outlet connectors for powering multiple items from a single cable
 - Tru-Line locking connectors provide a secure connection to prevent unexpected power loss from pulled cables
- Warranty
 - 12 gauge, 5-year
 - 14 gauge, 3-year

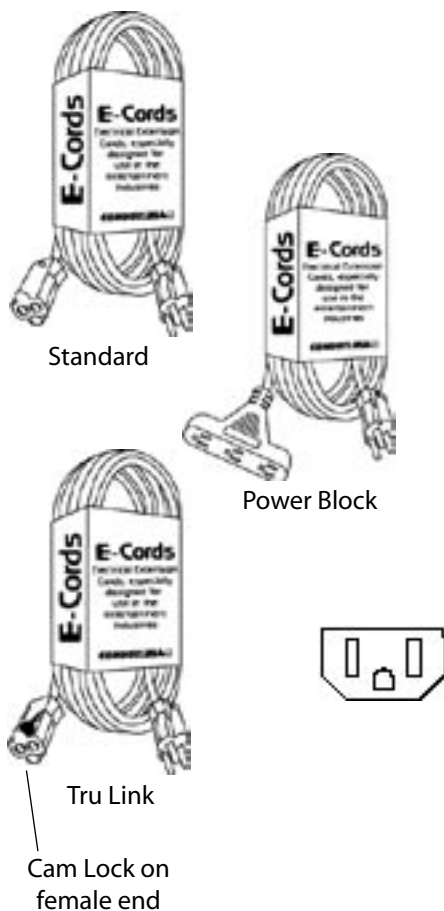

Model No.	Description	Suggested Resale
E163-6	Electrical Extension Cord, 16 g., 3-con, 6'	\$7.49
E163-12	Electrical Extension Cord, 16 g., 3-con, 12'	\$8.49
E163-25	Electrical Extension Cord, 16 g., 3-con, 25'	\$15.49
E163-50	Electrical Extension Cord, 16 g., 3-con, 50'	\$31.99
E143-1PB	Electrical Extension Cord, 14 g., 3-con, 1' w/Power Block	\$7.99
E143-6PB	Electrical Extension Cord, 14 g., 3-con, 6' w/Power Block	\$9.49
E143-12PB	Electrical Extension Cord, 14 g., 3-con, 12' w/Power Block	\$12.49
E143-25PB	Electrical Extension Cord, 14 g., 3-con, 25' w/Power Block	\$19.49
E143-50PB	Electrical Extension Cord, 14 g., 3-con, 50' w/Power Block	\$36.99
E123-25	Electrical Extension Cord, 12 g., 3-con, 25'	\$37.49
E123-25PB	Electrical Extension Cord, 12 g., 3-con, 25' w/Power Block	\$42.99
E123-50	Electrical Extension Cord, 12 g., 3-con, 50'	\$37.49
E123-50PB	Electrical Extension Cord, 12 g., 3-con, 50' w/Power Block	\$57.99
E123-100	Electrical Extension Cord, 12 g., 3-con, 100'	\$76.99
E123-25TL	Electrical Extension Cord, 12 g., 3-con, 25' w/Tru Link	\$37.49
E123-50TL	Electrical Extension Cord, 12 g., 3-con, 50' w/Tru Link	\$54.99
E183-2IEC	Electrical Extension Cord, 18 g., 3-con, IEC female to Edison male, 2'	\$5.99



Tru Link locks the extension cords together so that they will NEVER come undone, no matter how hard you pull!*

* OK, OK, you really strong guys could probably prove this wrong.

MultiTrack Cables



Analog D-Sub (DB25) Multitrack Recording Cables

Originally designed to connect TASCAM DA88 digital audio tape recorders to the various mixing consoles available, these work with Mackie, Tascam and Pro Tools I/O. This pinout will also work with Radar and Otari to name the major players

- Pro Co ArmorFlex jacketed Acculink Multipair 8 channel wire, clearly numbered pairs for easy identification, 100% foil shielded.
- Showsaver 1/4" T/R/S connectors or Neutrik XLR connectors
- Amphenol DB25 (D-Sub) connectors on all multitrack products
- NOTE: There are, unfortunately, two different thread standards for D-Subs — Metric and English. Pro Co supplies both sets of screws for your convenience.
- 20 year warranty

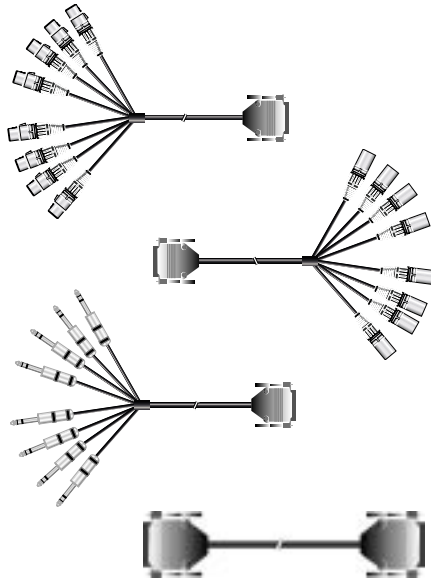

DA88XF Amphenol DB25 multipin connector wired to 8 Neutrik XLR 3-pin female connectors.

DA88XM Amphenol DB25 multipin connector wired to 8 Neutrik XLR 3-pin male connectors.

DA88BQ Amphenol DB 25 multipin connector wired to 8 ShowSavers T/R/S phone plugs.

DA88DM Amphenol DB25 multipin connector wired to DB25 multipin connector .

Model Number	Length in Feet	Suggested Resale
DA88XF-5	5	\$138.49
DA88XF-10	10	\$127.99
DA88XF-15	15	\$148.49
DA88XF-20	20	\$158.99
DA88XM-5	5	\$125.49
DA88XM-10	10	\$135.99
DA88XM-15	15	\$147.99
DA88XM-20	20	\$156.49
DA88BQ-5	5	\$135.49
DA88BQ-10	10	\$142.99
DA88BQ-15	15	\$156.49
DA88BQ-20	20	\$166.99
DA88DM-5	5	\$103.49
DA88DM-10	10	\$113.99
DA88DM-15	15	\$124.49
DA88DM-20	20	\$134.99

Digital Multitrack Recording Harnesses

8 channel multitrack recording cables designed specifically to connect the emerging number of hard disk recorders and digital mixing consoles now available.

- 8 channel Acculink Digital ArmorFlex jacketed multipair wire, 110Ω digital standard to conform to AES/EBU.
- Neutrik digital XCR's
- 5 year warranty

MTD8XIO - digital I/O multitrack cable 8 channel 110Ω digital Acculink wire with four Neutrik XLR males (channels 1-4) and four Neutrik XLR females (channels 5-8) on one end and four Neutrik XLR females (channels 1-4) and four Neutrik XLR males (channels 5-8) on the other.

DD8MXMXF 8 channel Acculink Digital ArmorFlex jacketed multipair wire, on one end wired one Amphenol Digital XCRs 25-pin D-Sub (I/O harness, for Mackie AES/EBU interface) to 4 Neutrik XLR males in, 4 Neutrik XLR females out on the other.

DD8YXMXF 8 channel Acculink Digital ArmorFlex jacketed multipair wire, on one end wired one Amphenol 25-pin D-Sub (I/O harness, for Yamaha AES/EBU interface) to 4 Neutrik XLR males in, 4 Neutrik XLR females out on the

Model Number	Length in Feet	Suggested Resale
MTD8XIO-10	10	\$220.99
MTD8XIO-20	20	\$244.49
DD8MXMXF-10	10	\$133.49
DD8MXMXF-20	20	\$157.49
DD8YXMXF-10	10	\$133.49
DD8YXMXF-20	20	\$157.49

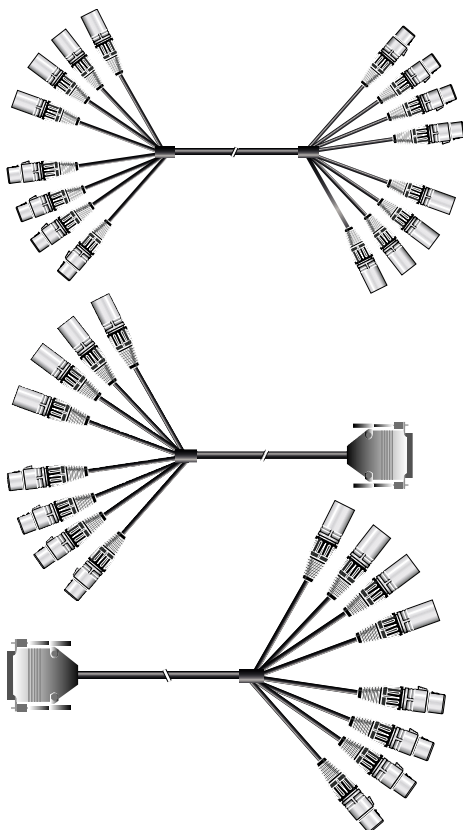

MultiTrack Cables



Analog Studio Harness Cables

A variety of general use multitrack cables, in various channel counts and endless end configurations and lengths.

- 8, 16 and 24 channel models available using Pro Co Acculink ArmorFlex jacketed multipair wire, clearly numbered pairs for easy identification, 100% foil shielded
- Standard lengths are 10 and 20 feet, but any length is available
- Neutrik XLRs, ShowSavers 1/4" T/S and T/R/S phone plugs and Pro Co HD RCAs used
- 20 year warranty

	Model Number	Length in Feet	Suggested Resale
MT8RR 8 channel Acculink wire with 8 Pro Co HD RCAs on each end.	MT8RR-10	10	\$115.99
	MT8RR-20	20	\$135.99
MT8QR 8 channel Acculink wire with 8 ShowSavers 1/4" T/S connectors on one end to 8 Pro Co HD RCAs on the other	MT8QR-10	10	\$122.49
	MT8QR-20	20	\$143.49
MT8QQ 8 channel Acculink wire with 8 ShowSavers 1/4" T/S connectors on each end	MT8QQ-10	10	\$129.49
	MT8QQ-20	20	\$149.49
MT8BQBQ 8 channel Acculink wire with 8 ShowSavers 1/4" T/R/S connectors on each end	MT8BQBQ-10	10	\$174.49
	MT8BQBQ-20	20	\$194.99
MT8BQXM 8 channel Acculink wire with 8 Neutrik XLR 3-pin females on one end and 8 Neutrik XLR 3-pin males on the other	MT8FXM-10	10	\$164.99
	MT8FXM-20	20	\$184.49
MT8BQXF 8 channel Acculink wire with 8 ShowSavers 1/4" T/R/S phone plugs on one end and 8 Neutrik XLR 3-pin females on the other	MT8BQXF-10	10	\$167.49
	MT8BQXF-20	20	\$186.99
MT16RR 16 channel Acculink wire with 16 Pro Co HD RCAs on each end.	MT16RR-10	10	\$164.99
	MT16RR-20	20	\$174.99
MT16QR 16 channel Acculink wire with 16 ShowSavers 1/4" T/S connector on one end to 16 Pro Co HD RCA on the other	MT16QR-10	10	\$180.49
	MT16QR-20	20	\$196.49
MT16QQ 16 channel Acculink wire with 16 ShowSavers 1/4" T/S connectors on each end	MT16QQ-10	10	\$184.49
	MT16QQ-20	20	\$226.99
MT16BQBQ 16 channel Acculink wire with 16 ShowSavers 1/4" T/R/S connectors on each end	MT16BQBQ-10	10	\$280.49
	MT16BQBQ-20	20	\$319.99
MT16BQXM 16 channel Acculink wire with 16 Neutrik XLR 3-pin females on one end and 16 Neutrik XLR 3-pin males on the other	MT16FXM-10	10	\$261.99
	MT16FXM-20	20	\$299.99
MT16BQXF 16 channel Acculink wire with 16 ShowSavers 1/4" T/R/S phone plugs on one end and 16 Neutrik XLR 3-pin females on the other	MT16BQXF-10	10	\$266.49
	MT16BQXF-20	20	\$285.49
MT24BQBQ 26 channel Acculink wire with 24 ShowSavers 1/4" T/R/S connectors on each end	MT24BQBQ-10	10	\$387.49
	MT24BQBQ-20	20	\$446.99
MT24BQXM 26 channel Acculink wire with 24 Neutrik XLR 3-pin females on one end and 24 Neutrik XLR 3-pin males on the other	MT24FXM-10	10	\$358.99
	MT24FXM-20	20	\$417.99
MT24BQXF 26 channel Acculink wire with 24 ShowSavers	MT24BQXF-10	10	\$365.99
	MT24BQXF-20	20	\$424.99

MultiTrack Cables



ADATX shown above.

Alesis ADAT Multitrack Recording Cables

Designed to connect Alesis ADAT digital audio tape recorders to the various mixing consoles available.

- Pro Co ArmorFlex jacketed Acculink™ multipair 16 channel wire, clearly numbered pairs for easy identification, 100% foil shielded.
- Showsavers 1/4" T/R/S connectors or Neutrik XLR connectors
- Elco/Edac 56 pin multipin connectors
- 20 year warranty

ADATX Adat to XLR harness. One Elco/Edac multipin connector wired to eight Neutrik XLR 3-pin male and female connectors

Model Number	Length in Feet	Suggested Resale
ADATX-5	5	\$275.49
ADATX-10	10	\$305.99
ADATX-15	15	\$330.49
ADATX-20	20	\$327.99

ADATBQ Adat to T/R/S balanced quarter harness. One Elco/Edac multipin connector wired to sixteen ShowSavers 1/4" T/R/S phone plugs

ADATBQ-5	5	\$301.49
ADATBQ-10	10	\$326.99
ADATBQ-15	15	\$350.49
ADATBQ-20	20	\$354.49

ADATM600 Adat to D-sub harness. One Elco/Edac multipin connector wired to two DB25 connectors, labeled send and return

ADATM600-5	5	\$148.49
ADATM600-10	10	\$231.49
ADATM600-15	15	\$235.49
ADATM600-20	20	\$271.99

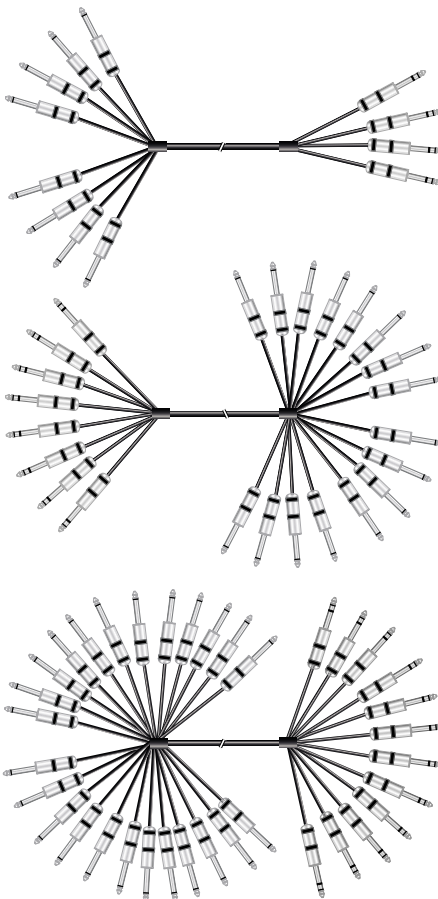

Insert Patch Snakes

MTIP0408Q 8 channel Acculink multipair cable wired four ShowSavers 1/4" T/R/S phone plugs on one end each wired to two ShowSavers 1/4" T/S phone plugs on the other. This provides four individual insert cables (send/return) per assembly.

Model Number	Length in Feet	Suggested Resale
MTIP0408Q-10	10	\$129.99
MTIP0408Q-20	20	\$151.49

MTIP0816Q 16 channel Acculink multipair cable wired eight ShowSavers 1/4" T/R/S phone plugs on one end each wired to two ShowSavers 1/4" T/S phone plugs on the other. This provides eight individual insert cables (send/return) per assembly.

MTIP0816Q-10	10	\$194.99
MTIP0816Q-20	20	\$233.49

MTIP1224Q 26 channel Acculink multipair cable wire twelve ShowSavers 1/4" T/R/S phone plugs on one end each wired to two ShowSavers 1/4" T/S phone plugs on the other. This provides 12 individual insert cables (send/return) per assembly.

MTIP1224Q-10	10	\$316.49
MTIP1224Q-20	20	\$359.99

Snakes



StageMASTER Brand Snakes

Very cleverly designed by Pro Co director of engineering, Gerry Carpenter, these snakes are so logically thought out and designed for manufacturability that they compete with snakes on a quality level with any competitors' products costing up to 50% more than ours. Perfect for weekender bands, church and school traveling contemporary music groups and for light to medium duty auditorium use, StageMASTER snakes are available in a variety of channel counts and lengths.

- Design provides rugged products at a very inexpensive price
- Available in 12, 16, 20, 28 and 32 channel configurations in lengths starting at 25' up to 250'
- 5 year warranty
- Assembled in Neutrik's Chinese Facility.

Fan to box multipair audio cables (Snakes) with XLR returns

Second generation Duralink multipair audio cable and an all-new indestructible high-tech aluminum chassis with Neutrik XLR connectors.

Fan to box multipair audio cables (Snakes) with 1/4" returns

Second generation Duralink multipair audio cable and an all-new indestructible high-tech aluminum chassis with XLR connectors and 1/4" connectors.

Model Number	Length in Feet	Suggested Resale
SMA1604FBX-100	100	\$506.99
SMA2404FBX-100	100	\$634.99
SMA0804FBQ-25	25	\$234.99
SMA0804FBQ-50	50	\$279.99
SMA0804FBQ-100	100	\$367.99
SMA1204FBQ-50	50	\$341.99
SMA1204FBQ-100	100	\$466.99
SMA1604FBQ-50	50	\$399.99
SMA1604FBQ-100	100	\$499.99
SMA2404FBQ-100	100	\$634.99
SMA2404FBQ-150	150	\$874.99

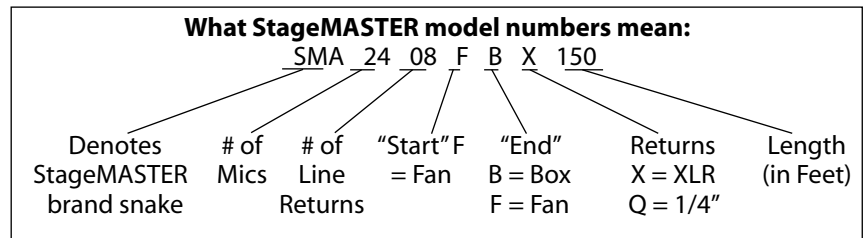

Snakes



RoadMASTER Brand Snakes

Perfect small PA company snakes, with rugged steel stage boxes and sturdy color-coded fanouts, with configurations up to 40 channels. Options include hardwired feedthrough and disconnect splits (with optional transformer isolation and ground lift switches available). Call the factory for quotes and details.

- Standard configurations are hardwired. Disconnect splits are optional.
- 8, 12, 16, 20, 24, 28, 32 and 40 channel models are available
- 10 year warranty
- Neutrik XLR and ShowSavers 1/4" plug are used

Fan to box hardwired multipair audio snakes (XLR) returns

Second generation Duralink multipair audio wire with heavy-duty 12 and 16 gauge steel stage box to color coded all XLR fan assembly.

Model Number	Length in Feet	Suggested Resale
RM0602FBX-50	50	\$428.49
RM0602FBX-100	100	\$491.99
RM0804FBX-50	50	\$496.49
RM0804FBX-100	100	\$589.99
RM0804FBX-150	150	\$683.49
RM1204FBX-50	50	\$582.49
RM1204FBX-100	100	\$704.49
RM1204FBX-150	150	\$826.49
RM1604FBX-50	50	\$630.49
RM1604FBX-100	100	\$786.49
RM1604FBX-150	150	\$929.49
RM2404FBX-50	50	\$807.99
RM2404FBX-100	100	\$1,009.99
RM2404FBX-150	150	\$1,210.99
RM2408FBX-50	50	\$988.99
RM2408FBX-100	100	\$1,204.49
RM2408FBX-150	150	\$1,456.99
RM3208FBX-50	50	\$1,237.99
RM3208FBX-100	100	\$1,425.49
RM3208FBX-150	150	\$1,727.99

What RoadMASTER model numbers mean:

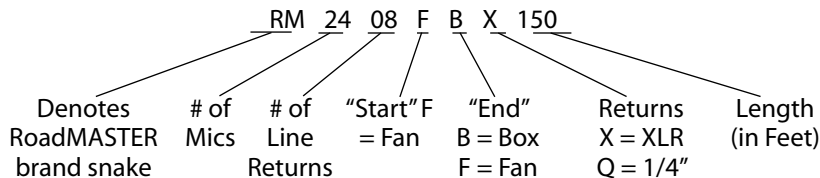

Fan to box hardwired multipair audio snakes with 1/4" returns

Second generation Duralink multipair audio wire with heavy-duty 12 and 16 gauge steel stage box to color coded XLR and balanced 1/4" fan assembly.

RM0602FBQ-50	50	\$437.49
RM0602FBQ-100	100	\$553.99
RM0804FBQ-50	50	\$513.99
RM0804FBQ-100	100	\$644.99
RM0804FBQ-150	150	\$775.49
RM1204FBQ-50	50	\$599.99
RM1204FBQ-100	100	\$721.99
RM1204FBQ-150	150	\$934.49
RM1604FBQ-50	50	\$648.49
RM1604FBQ-100	100	\$797.99
RM1604FBQ-150	150	\$856.99
RM2404FBQ-50	50	\$908.99
RM2404FBQ-100	100	\$1,027.49
RM2404FBQ-150	150	\$1,225.99
RM2408FBQ-50	50	\$987.99
RM2408FBQ-100	100	\$1,239.99
RM2408FBQ-150	150	\$1,491.99
RM3208FBQ-50	50	\$1,142.99
RM3208FBQ-100	100	\$1,463.99
RM3208FBQ-150	150	\$1,706.49

Need a custom snake? No problem! Call your Pro Co sales person today for help with our new Segos™ line of design-it-yourself snakes...800/253-7360

Fan to fan hardwired multipair audio snakes

Second generation Duralink multipair audio wire with heavy-duty color coded fan to fan assembly any combination of 3 pin XLR male to XLR female.

RM0800FF-25	25	\$168.49
RM0800FF-50	50	\$200.49
RM0800FF-100	100	\$263.49
RM1200FF-25	25	\$233.99
RM1200FF-50	50	\$280.99
RM1200FF-100	100	\$375.99

Snakes

New for 2002

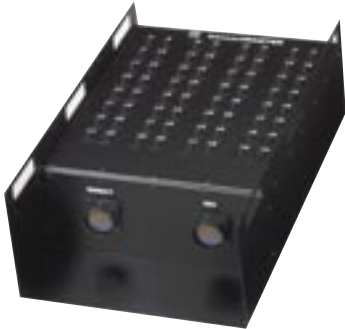

Floor Box CM-MBDX5608



Rack Box CM-MRDX5608



Fanout CM-MTX5608-4



Linetails CM-LTX5608-25



Extension Trunk CM-MK6400EX-25



Trunk CM-MK6400-25

ConcertMASTER Brand Professional Touring Snakes

Finally an alternative to the industry standard 56 channel snakes currently available, ConcertMASTER provides up to 64 channels, with 48 and 56 channel snakes also available in all necessary configurations, complete with disconnects, with optional transformer isolation and ground lifts, with our new sturdy ConcertMASTER multipin disconnects available in a wide variety of channel counts.

- Disconnects are standard, however hardwired systems are options.
- These are expensive, top of the craft systems for touring sound companies, Broadway shows, college and large church sound systems and other professional entertainers on the go.
- Rack and floor boxes available as standard
- 5 year warranty

Representative Resale Pricing

Using ConcertMASTER Connectors

	48 ch	56 ch	64 ch
Dual output box (Rack or Floor)	\$2,512	\$2,705	\$2,901
8' Fanout (male multipin)	\$1,093	\$1,263	\$1,430
25' Linetail (female multipin)	\$1,385	\$1,625	\$1,850
50' Linetail (female multipin)	\$1,574	\$1,848	\$2,118
50' Trunk (2 female multipins)	\$1,679	\$2,007	\$2,281
100' Trunk (2 female multipins)	\$2,056	\$2,452	\$2,814
50' Extension trunk (male to female multipin)	\$1,502	\$1,780	\$2,022
100' Extension trunk (male to female multipin)	\$1,879	\$2,089	\$2,555
25' Line Box	\$2,864	\$2,925	\$3,547
25' Sub Box 16 ch	\$ 809		

Using MASS Connectors

	48 ch	56 ch
Dual output Box (Rack or Floor)	\$3,117	\$3,199
8' Fanout	\$1,377	\$1,486
25' Linetail	\$1,503	\$1,629
50' Linetail	\$1,692	\$1,852
50' Trunk	\$2,100	\$2,230
100' Trunk	\$2,477	\$2,675

Over 300 options for channel count and length are available. Call the factory for details.

New

Pro Co now offers Jensen Transformers

Pro Co Sound and Jensen Transformers are excited to announce that Pro Co's ConcertMaster brand of snakes is now available with Jensen microphone bridging transformers as standard offerings. This allows you to purchase the world standard in audio transformers in catalog items, eliminating long leadtimes and custom pricing.

MU-Metal Cans

Pro Co has added MU-metal cans to its MBT-1 and MBT-2 open-frame microphone bridging transformers, lowering their noise floor substantially, as well as adding 100X better ability for them to block magnetic fields. Their hum-rejection in racks, or in close proximity to other transformers is dramatically improved. These improved transformers will replace current models at little to no increase in price effective 1/1/04.



Line Box CM-LB6400-25



Options

Instrument Cable Options Chart

	Add to suggested resale prices				
	Defender	Sir Tweed	Excalibur	ProPatch	Excellines
1 right angle phone plug	\$9.00	\$4.40		\$3.90	\$3.40
2 right angle phone plugs				\$7.80	\$6.80
1 straight quiet plug	\$2.00	\$4.00	\$3.00	\$3.00	\$3.00
1 right angle quiet plug	\$11.00	\$11.00		\$4.00	\$4.00
2 gold straight plugs			\$8.00		
1 right angle gold plug, 1 straight gold plug	\$7.00	\$5.00			
1 gold quiet plug, 1 gold straight plug	\$9.00	\$7.00			
1 right angle gold quiet plug, 1 straight gold plug	\$10.00	\$8.00			
2 cocobola wood handles, straight plug		\$12.00			

Combinations of some of the above are also available, for instance, a Sir Tweed with cocobola wood handles and 2 gold straight plugs. Call for pricing.



Sir Tweed Woody



Right angle plug.

Microphone Cable Options

Mastermike and Ameriquad cables are available with a right angle plug on either or both ends.

Add \$7.00 for each right angle plug

Color bands available on Ameriquad and Mastermike only for easy identification.

Add \$.75 for a pair of color bands on each cable.

On/Off switches are available on AmeriQuad and MasterMike assemblies for \$8.50 additional resale per cable.

Speaker Cable Options

All Speaker cables are available with a right angle 1/4" or Speakon plug on either or both ends.

Add \$11.00 for each Speakon right angle plug (12 ga.)

Add \$3.40 for each right angle 1/4" plug (14 and 16 ga.)

Wall Plate Options

All standard wallplates are available in economy brushed aluminum black anodized plates at no extra charge.

Put a "B" at the end of the part number to order. Amphenol AM3FDPIIL IDC connectors are available on WP1042s, WP1043s, WP2009's and WP2011s at no extra charge. Put an "I" at the end of the part number to order.

TradeTools Direct Boxes

TradeTools are black-box products, built as a result of 22 years of “Can’t you just?” requests by our customers for standard products rather than custom ones to do a specific task.

We build absolutely, positively the 2nd best transformers in the audio business (Jensen makes the best). It took us years to design transformers we were satisfied with, and they work and sound par excellence — at way under 1/2 the cost of the other guys. (Our 3dB downpoint is only an octave higher than the best).

The boxes are built like a tank so they can be abused by life on the road. We do not need a bunny and a battery to keep these workhorses going. If you think the washer repairman on TV is bored, you should look in on the Pro Co TradeTools repair-person sometime.

TradeTools will outlast the lifespan of the gear they are interfacing, yet are inexpensive to build and own. Get your system connected the right way, the first time with TradeTools .



DB4A QUAD DIRECT BOX

4-channel professional quality passive direct box for connection of unbalanced musical instruments and line-level sources to low-Z balanced microphone inputs for PA or recording. Each channel features 1 front-panel and 2 rear-panel 1/4" (ø6.35mm) jacks for input or parallel output, switches for line-level attenuation and ground lift, and front-panel male XLR-type output. Uses Pro Co DBT-1 transformers (20k/150Ω).

Model Number DB4A
Suggested Resale \$388.00

Model Number DBJA (with Jensen transformers)
Suggested Resale \$720.00



DB1 PROFESSIONAL DIRECT BOX

Professional quality passive direct box for connection of unbalanced musical instruments, line-level sources, and guitar amplifier outputs to low-Z balanced microphone input for PA or recording. 1/4" (6.35mm) input (with parallel 1/4" output). Switches for speaker/line-level attenuation, high-cut filter, and ground lift. Male XLR-type balanced mic-level output. Uses Pro Co DBT-1 transformer (20k/150Ω).

Model Number DB1
Suggested Resale \$110.00

Model Number DBJ1 (with Jensen transformers)
Suggested Resale \$174.00

New

Pro Co now offers Jensen Transformers

Pro Co Sound and Jensen Transformers are excited to announce that many of Pro Co's TradeTools are now available with Jensen Transformers as a step up to Pro Co's own brand. Pro Co now offers Jensen's world standard in audio transformers in catalog items, eliminating long leadtime and custom pricing.

MU-Metal Cans

Pro Co has added MU-metal cans to its DBT-1 open-frame microphone bridging transformers, lowering their noise floor substantially, as well as adding 100X better ability for them to block magnetic fields. Their hum-rejection in racks, or in close proximity to other transformers is dramatically improved. These improved transformers will replace current models at little to no increase in price effective 1/1/04.



CB1 PASSIVE DIRECT BOX

Passive direct box for connection of unbalanced musical instruments and line-level sources to low-Z balanced microphone input for PA or recording. Not recommended for speaker-level use. 1/4" (6.35mm) input (with parallel 1/4" output). Switch for ground lift. Male XLR-type balanced mic-level output. Uses Pro Co CBT-1 transformer (20k/150Ω).

Model Number CB1
Suggested Resale \$62.49

Cough Suppressor



CD1 Cough Drop

Momentary foot switch to allow operator to turn and hold the microphone off, and then quickly resume live by releasing the switch. Great for sportscasters and singers.

Model Number CD1
Suggested Resale \$55.99

New Cough Suppressors will be out soon. In the interim, for immediate delivery is the CDL1 with a latching switch (the CD1's switch is momentary) for the same price.

TradeTools Interface Boxes



AV1A AUDIO/VIDEO INTERFACE

For connection of film projectors, tape recorders, and computers to standard low-Z balanced microphone input of public address system. RCA, 1/4" stereo ($\varnothing 6.35\text{mm}$) and stereo mini-jack ($\varnothing 3.5\text{mm}$) inputs. Male XLR-type balanced mic-level output and unbalanced 1/4" line-level output. Switches for high/low level attenuation, 16 Ω load, and ground lift. Uses Pro Co DBT-1 transformer (20k/150 Ω).

Model Number AV1A

Suggested Resale \$130.49



AVP1STS WALLPLATE AUDIO/VIDEO INTERFACE

Interface projectors or tape machines to standard LO-Z microphone inputs on P.A. systems. Use this where a wallplate is preferable. Available in Black, Stainless Steel or Brass.

Model Number AVP1STS (Stainless Steel)

Suggested Resale \$114.99

Shown in optional black finish (AVP1BLK)



AVP1VSTS WALLPLATE AUDIO/VIDEO INTERFACE

Interface projectors or tape machines to standard LO-Z microphone inputs on P.A. systems. Includes variable input level control.

Model Number AVP1VSTS (Stainless Steel)

Suggested Resale \$161.99

Shown in optional black (AVP1VBLK)

TradeTools Signal Isolators



IT4A

4-CHANNEL ISOLATION TRANSFORMER UNIT

For balancing and isolation of line-level outputs from mixers, equalizers, crossovers, and other equipment. 4 channels, each with 1/4" (ø6.35mm) T/R/S and female XLR-type input, and 1/4" T/R/S and male XLR-type isolated output with ground lift switch. Uses Pro Co LOT-1 transformers (600Ω 1:1).

Model Number IT4A
Suggested Resale \$384.00

Model Number ITJ4A (with Jensen transformers)
Suggested Resale \$608.00



IT8A

8-CHANNEL ISOLATION TRANSFORMER UNIT

For balancing and isolation of line-level outputs from mixers, equalizers, crossovers, and other equipment. 8 channels, each with female XLR-type input, and male XLR-type isolated output with ground lift switch. Uses Pro Co LOT-1 transformers (600Ω 1:1).

Model Number IT8A
Suggested Resale \$598.00

Model Number ITJ8A (with Jensen transformers)
Suggested Resale \$1056.00



IT1

ISOLATION TRANSFORMER UNIT

For balancing and isolation of line-level outputs from mixers, equalizers, crossovers, and other equipment. 1/4" (6.35mm) T/R/S and female XLR-type input (with parallel 1/4" and male XLR-type output). 1/4" T/R/S and male XLR-type transformer isolated outputs with ground lift switch. Uses Pro Co LOT-1 transformer (600Ω 1:1).

Model Number IT1
Suggested Resale \$120.00

Model Number ITJ1 (with Jensen transformers)
Suggested Resale \$162.00

New

Pro Co now offers Jensen Transformers

Pro Co Sound and Jensen Transformers are excited to announce that many of Pro Co's TradeTools are now available with Jensen Transformers as a step up to Pro Co's own brand. Pro Co now offers Jensen's world standard in audio transformers in catalog items, eliminating long leadtime and custom pricing.

MU-Metal Cans

Pro Co has added MU-metal cans to its MBT-1 and MBT-2 open-frame microphone bridging transformers, lowering their noise floor substantially, as well as adding 100X better ability for them to block magnetic fields. Their hum-rejection in racks, or in close proximity to other transformers is dramatically improved. These improved transformers will replace current models at little to no increase in price effective 1/1/04.

Microphone Combiner



MC2

MICROPHONE COMBINER

For combining the signals from 2 low-Z balanced microphones to 1 mixer input. 2 female XLR-type inputs (one with polarity reverse switch). Male XLR-type isolated output. Uses Pro Co MBT-2 transformer (150Ω 1:1:1).

Model Number MC2
Suggested Resale \$131.99

TradeTools Microphone Splitters



MS42A

4 channels 1-in, 1-isolated, 1-direct outputs

Use to split LO-Z microphones to two mixer inputs. Handy four channel unit in one rack space with all connectors on one side.

Model Number MS42A

Suggested Resale \$350.00

Model Number MSJ42A (with Jensen transformers)

Suggested Resale \$680.00



MS43A

4 channels 1-in, 2-isolated, 1-direct outputs

Use to split LO-Z microphones to three mixer inputs. Handy four channel unit in one rack space.

Model Number MS43A

Suggested Resale \$436.00

Model Number MSJ43A (with Jensen transformers)

Suggested Resale \$1030.00



MS82

8 channels 1-in, 1-isolated, 1-direct outputs, I/O via Phoenix Combo-Con™

Use to split LO-Z microphones to two mixer inputs. Handy eight channel unit in one rack space with I/O via Phoenix Combo-Con barriers.

Model Number MS82

Suggested Resale \$706.00

Model Number MSJ82 (with Jensen transformers)

Suggested Resale \$1422.00



MS82P

8 channels 1-in, 1-isolated, 1-direct outputs, I/O via Phoenix Combo-Con™

Use to split LO-Z microphones to two mixer inputs. Handy eight channel unit in one rack space with I/O via Phoenix Combo-Con barriers. Includes internal phantom power bus. (Power supply not included).

Model Number MS82P

Suggested Resale \$746.00

Model Number MSJ82P (with Jensen transformers)

Suggested Resale \$1462.00

PPS48 Phantom Power Supply \$93.99



MS83

8 channels 1-in, 2-isolated, 1-direct outputs, I/O via Phoenix Combo-Con™

Use to split LO-Z microphones to three mixer inputs. Handy eight channel unit in one rack space with I/O via Phoenix Combo-Con barriers.

Model Number MS83

Suggested Resale \$926.00

Model Number MSJ83 (with Jensen transformers)

Suggested Resale \$2140.00



MS83P

8 channels 1-in, 2-isolated, 1-direct outputs, I/O via Phoenix Combo-Con™

Use to split LO-Z microphones to three mixer inputs. Handy eight channel unit in one rack space with I/O via Phoenix Combo-Con barriers. Includes internal phantom power bus. (Power supply not included).

Model Number MS83P

Suggested Resale \$966.00

Model Number MSJ83P (with Jensen transformers)

Suggested Resale \$2180.00

PPS48 Phantom Power Supply \$93.99

New

Pro Co now offers Jensen Transformers

Pro Co Sound and Jensen Transformers are excited to announce that many of Pro Co's TradeTools are now available with Jensen Transformers as a step up to Pro Co's own brand. Pro Co now offers Jensen's world standard in audio transformers in catalog items, eliminating long leadtime and custom pricing.

MU-Metal Cans

Pro Co has added MU-metal cans to its MBT-1 and MBT-2 open-frame microphone bridging transformers, lowering their noise floor substantially, as well as adding 100X better ability for them to block magnetic fields. Their hum-rejection in racks, or in close proximity to other transformers is dramatically improved. These improved transformers will replace current models at little to no increase in price effective 1/1/04.

TradeTools Microphone Splitters



MS-2

1-INTO-2 Microphone Splitter

For splitting the signal from a low-Z balanced microphone between 2 mixers. Female XLR-type input. 2 male XLR-type outputs (Direct and Isolated). Isolated output has ground lift switch. Uses Pro Co MBT-1 transformer (150Ω 1:1).

Model Number MS2

Suggested Resale \$106.00

Model Number MSJ2 (with Jensen transformers)

Suggested Resale \$176.00



MS-3

1-INTO-3 Microphone Splitter

For splitting the signal from a low-Z balanced microphone between 3 mixers. Female XLR-type input. 3 male XLR-type outputs (1 Direct and 2 Isolated). Isolated outputs have ground lift switches. Uses Pro Co MBT-2 transformer (150Ω 1:1:1).

Model Number MS3

Suggested Resale \$130.00

Model Number MSJ3 (with Jensen transformers)

Suggested Resale \$262.00

Line Level Splitter



LS82

Line Level Splitter: 8 channels 1-isolated, 1-direct output

1-isolated out, 1-direct out, I/O via Phoenix Combo-Con™. Use to split, balance, and isolate line level outputs to one or two line level inputs. Eight channels in one rack space unit. Uses Pro Co Lot-1 transformer (600Ω 1:1).

Model Number LS82

Suggested Resale \$798.00

Model Number LSJ82 (with Jensen transformers)

Suggested Resale \$1388.00

New

Pro Co now offers Jensen Transformers

Pro Co Sound and Jensen Transformers are excited to announce that many of Pro Co's TradeTools are now available with Jensen Transformers as a step up to Pro Co's own brand. Pro Co now offers Jensen's world standard in audio transformers in catalog items, eliminating long leadtime and custom pricing.

MU-Metal Cans

Pro Co has added MU-metal cans to its MBT-1 and MBT-2 open-frame microphone bridging transformers, lowering their noise floor substantially, as well as adding 100X better ability for them to block magnetic fields. Their hum-rejection in racks, or in close proximity to other transformers is dramatically improved. These improved transformers will replace current models at little to no increase in price effective 1/1/04.

Monitor Speaker Selectors



Switch Witch

Powered Monitor Selector

A simple, effective line level speaker switcher that allows the user to select up to four pairs of speakers from a single balanced stereo line level source. All ins and outs are balanced on XLR connectors.

Model Number Switch Witch

Suggested Resale \$299.99

TradeTools Retail Demonstration Switchers

Instore Display Switchers

Use these new Pro Co instore display switches as solutions to the never-ending problem of keeping pro audio rooms organized and operational, ready to demo "now".



The DFX12 Demo Effects Switcher allows for up to twelve (12) stereo effects units to be demoed at once. Units can be easily daisy-chained to increase channel count where needed. The unit's outputs have been parallel wired so the customer can listen through an instore monitoring system, or the signal can be sent to a recorder for later playback or sent to headphones via the DFX12's built-in headphone amp.

The DFX12 is a dual rack space unit that can be mounted in any standard 19" rack. The switching is accomplished using twenty-four (24) DPDT (double-pole double-throw) heavy-duty miniature toggle switches, located on the front panel of the unit, allowing any individual output or combination of the outputs to be fed to the stereo unit. All inputs and outputs are balanced 1/4" T/R/S jacks. A power supply is provided.

Model Number DFX12
Suggested Resale \$1,846.99



The DMPS12H Demo Mic Preamp Selector allows for up to twelve (12) mic preamps and two (2) microphones to be demoed at once. The unit's outputs have been parallel wired so the customer can listen through an instore monitoring system, or the signal can be sent to a recorder for later playback or sent to headphones via the DMPS12H's built-in headphone amp.

The DMPS12H is a single rack space unit that can be mounted in any standard 19" rack. The switching is accomplished using twelve (12) DPDT (double-pole, double-throw) heavy-duty miniature toggle switches, located on the front panel of the unit, allowing any individual output or combination of the outputs to be fed to the mic preamp. Inputs are three (3) pin female XLRs, and patch points and outputs use balanced 1/4" T/R/S jacks. A power supply is provided.

Model Number DMPS12H
Suggested Resale \$1,182.49



The DMS8 Demo Monitor Selector allows for up to eight (8) stereo pairs of powered or unpowered near-field monitors or PA speakers to be demoed at once. Units can be easily daisy-chained to increase channel count where needed.

The DMS8 is a single rack space unit that can be mounted in any standard 19" rack. The switching is accomplished using eight (8) 4PDT (four-pole, double-throw) heavy-duty miniature toggle switches, located on the front panel of the unit, allowing any individual output or combination of the outputs to be fed to the stereo pair. All inputs and outputs are balanced 1/4" T/R/S jacks.

Model Number DMS8
Suggested Resale \$528.49

These switchers are all built like a tank and are warranted against failure for five years from date of purchase. The units add a professional touch to all pro audio room displays, whether for recording or PA use.

TradeTools **Kwik Fixer Series**



ITX Series Inline Transformers

ITX is a compact custom-made audio isolation transformer providing a floating XLR-type output from an unbalanced source in a convenient package. Female XLR-type input. Male XLR-type output. Usable for 600Ω 1:1.

ITX-Q is the same as ITX, but with a 1/4" (ø6.35mm) phone plug input. Male XLR-type output. Tip wired in-phase with pin-2. Usable for 600Ω 1:1.

ITX-BQ is the same as ITX, but with a 1/4" T/R/S phone plug input. Male XLR-type output. Tip wired in-phase with pin-2. Usable for 600Ω 1:1.

Model Number ITX **Suggested Retail \$62.99**

Model Number ITX-Q **Suggested Retail \$66.99**

Model Number ITX-BQ **Suggested Retail \$70.49**



Max Series Microphone Attenuators

Female XLR-type input. Male XLR-type output. For low-Z (150Ω) microphones.

MAX-10 provides 10 dB attenuation (pad).

MAX-20 provides 20 dB attenuation (pad).

MAX-30 provides 30 dB attenuation (pad).

Model Number MAX-10 **Suggested Retail \$30.99**

Model Number MAX-20 **Suggested Retail \$30.99**

Model Number MAX-30 **Suggested Retail \$30.99**



LMX Adapter/Attenuator

Converts low-Z XLR-type microphone input to bridging 1/4" (ø6.35mm) line-level input. Allows low-Z XLR-type inputs to be used as line-level inputs (typically from unbalanced keyboards) to eliminate "de-normalizing" of tape signals and excessive patching. 1/4" T/R/S jack input. Male XLR-type output.

Model Number LMX **Suggested Retail \$31.99**



GLX Ground Lifter

Helps to eliminate PA/recording system hum and buzz. Pins 2 and 3 are carried through, Pin 1 is not. Female XLR-type input. Male XLR-type output.

Model Number GLX **Suggested Retail \$28.99**



9144PC Inline Transformer

Converts low-Z microphone to high-Z input for connecting a low-Z microphone to a high-Z PA input. Female XLR-type input. 1/4" (ø6.35mm) phone plug output. Uses 150Ω/150Ω transformer.

Model Number 9144PC **Suggested Retail \$62.49**



PRX Polarity Reverser

May be used to prevent out-of-phase cancellation and can be used to create special stereo effects. Pins 2 and 3 are cross-wired. Pin 1 is carried through. Female XLR-type input. Male XLR-type output.

Model Number PRX **Suggested Retail \$28.49**



Wiretap

The Wiretap is a male to female inline XLR connector (cigar) that ties pins 1, 2 and 3 on the XLR connector to a 4-terminal Phoenix combo-con connector. This provides technicians an immediate and easy-to-connect-to diagnostic point for use in testing audio systems once they have been installed. This allows any audio tester to be connected into a balanced XLR line without the time consuming mess that always seems to accompany such endeavors. The 4th terminal (not shown in picture) breaks ground if needed for testing purposes. Solves a multitude of "how to get at the signal" problems.

Model Number WTX **Suggested Retail \$56.49**

Model Number WTBQ **Suggested Retail \$56.49**

Patchbays

Patchbays

Pro Co sells audio patchbays in both 48 point PJ (military style) and TT (tiny telephone or bantam) types. ADC Pro Patch, Neutrik or Re'an patchpanels and many others are available in a number of standard formats.

Pro Co also offers custom wiring of these bays out to punch blocks, Elco multi-pins, or to whatever configurations are needed for the installation.

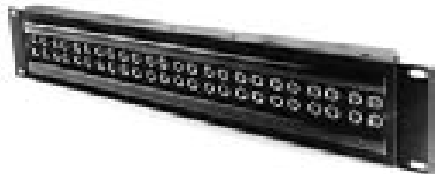

Model Number	Suggested Resale
TT1-96T	\$1,220.49
TT1-96H	\$1,339.49
TT1-96N	\$1,458.49
TT1-96TBC	\$1,890.74
TT1-96HS	\$1,506.99
TT1-96NS	\$1,625.99
TT1-96HSBC	\$2,171.49
TT1-96NSBC	\$2,290.49
PJ1-48T	\$797.49
PJ1-48H	\$797.49
PJ1-48N	\$797.49
PJ1-48TBC	\$1,132.49
PJ1-48HS	\$963.99
PJ1-48NS	\$963.99
PJ1-48HSBC	\$1,045.99
PJ1-48NSBC	\$1,298.99
PJ2-48T	\$709.99
PJ2-48H	\$709.99
PJ2-48N	\$709.99
PJ2-48TBC	\$1,044.99
PJ2-48HS	\$876.49
PJ2-48NS	\$876.49
PJ2-48HSBC	\$1,211.49
PJ2-48NSBC	\$1,211.49

Product Code for Patchbays

- TT Bantam Patchbay frame standard 19" rack mount.
- PJ WECO type 1/4" Patchbay frame standard 19" rack mount.
- T Loaded all open circuit non-normalizing 3-conductor jacks.
- H Loaded open circuit 3-conductor jacks top row, closed circuit 3-conductor jacks bottom row, for half normalizing.
- N Loaded all closed circuit 3-conductor jacks for full normalizing.
- 1, 2 etc. Following the TT or PJ code indicates 1 or 2 space panel.
- BC Indicates 8 ft. cabling to blunt cuts (6 ft. of wire after exit from bay).
- S Strapped normals at the bay.
- O Normals brought to the termination point.
- P SIEMON punch blocks for stranded wires, (6) 3-conductor terminators per block.
- 96, 48 - Following TT1, PJ2, etc. indicates the number of jacks loaded into panel.
- for half-normalizing, each jack-type is evenly divided.

All standard jackfields are supplied with blank designation strips.

All wired jackfields use Pro Co ACCULINK Multipair cable.

Standard grounding... sleeves jumped on all half-normalled and all normalled pairs.

Custom options are available. Call the factory for details and costs.

Rats



Vintage Rat

For 25 years, discerning guitarists have used the Rat's "magic" sound, its perfect blend of distortion, sustain and cutting power, usually found only at a volume too loud for club and studio work. Painstakingly researched and designed to produce a sound that is radically different from any "fuzztone" you have ever heard — a sound that sings and wails the blues, or spits and screeches the hardest rock'n roll. A sound that is as subtle as a vintage "twin", or as bone crushing as a wall of those famous English stacks. The Rat's smooth harmonic distortion and effortless sustain put the extra punch in rhythm work and makes solos cut through with authority and power.

Tune in just the right amount of overdrive, get the presence you need without any tinny treble, and balance the volume for the perfect extra "kick" for lead breaks. Distortion, sustain, fuzz, overdrive: the sound remains unmistakably yours. Not fake or gimmicky. Also the rat will not change the tone or power of your guitar when it is turned off; its true bypass switch disconnects it completely from the circuit when it is not in use, eliminating the loading effects common among other devices.

The Vintage Rat is a reissue of the original production models built circa 1977. It offers fat smooth distortion with effortless sustain. It gives a Marshall feel to Fender amps and humbucker muscle to single coil pickups. There is a wonderful natural compression to the Rat. As you search for your sound, you owe it to yourself to check out the Vintage Rat at great music stores everywhere.

VRAT Suggested Resale \$149.95

RPS1 (Bat elim.) Suggested Resale \$16.99



Rat 2

The Rat 2 offers the original Rat sound in a smaller, stronger compact housing with an LED status indicator. Researched and designed to produce a sound that is radically different from any distortion you have ever heard before — a sound as mellow as a vintage "twin", or as bone-crushingly powerful as a battery of those famous English stacks — instantly, at any volume.

Smooth, continuously variable controls for distortion amount, filter cutoff and volume level let you preset just the right degree of overdrive, tune in on the presence without any tinny treble, and balance the output for that perfect extra boost. The true bypass mode utilizes passive switching of both input and output from the signal path to eliminate the loss of power and clarity often caused by other devices. The Rat 2 has an LED indicator light which makes the on/off status easy-to-see-and glow-in-the-dark graphics and knob indicators for added visibility.

The Rat 2 is housed in Pro Co's inimitable massive steel enclosure with a simple-to-use no-tools-required battery compartment. The Rat 2 has been touted as an excellent defensive weapon during bar fights and is for all practical purposes unbreakable — built for the abuse and neglect of life on the road.

RAT2 Suggested Resale \$129.98

RPS1 (Bat elim.) Suggested Resale \$16.99



TurboRAT

Feel the crunch and power of the distortion pedal designed to take you to new and unexplored heights. The TurboRAT enables you to breakaway from the pack and drive beyond the realm of traditional distortion devices. Its 2.8V (P-P) output is more than double that of the Rat 2 and the Vintage Rat. Special care has been taken to preserve the hard-clipping harmonic distortion of the "great RAT tone" so that there is no sacrifice of sound in achieving its tremendous output.

The unit offers the same easy-to-use, smooth, variable controls for distortion amount, filter cutoff and volume level so you can preset just the right amount of overdrive, tune in on the presence — and FLY! In addition, the TurboRAT is housed in a sloped-face version of Pro Co's classic, virtually indestructible steel enclosure. The true bypass mode utilizes passive switching of both input and output from the signal path to eliminate the loss of power and clarity often caused by other devices. The TurboRAT has an LED indicator light which makes the on/off status easy to see and glow-in-the-dark graphics and knob indicators for added visibility.

The TurboRAT is a great overdrive pedal for enhancing a Marshall, has lower compression for a brighter tone, and like the Rat 2 is built for the abuse and neglect of life on the road.

TurboRAT Suggested Resale \$129.98

RPS1 (Bat elim.) Suggested Resale \$16.99



You Dirty RAT

You Dirty Rat, the latest revolution in stomp boxes is here. Pro Co Sound introduced the new You Dirty Rat, part of the Pro Co Rat line, at the winter NAMM 2004 show with much applause. In the late 70's the engineers at Pro Co Sound invented modern distortion pedals with their creation of the now famous RAT. The new You Dirty Rat now adds 3 dB of compression to our fuzz tone, creating attitude while giving the discerning player maximum sustain. According to Pro Co Sound insiders and some of the busiest guitarists in the world, You Dirty Rat has more fuzz than a police convention.

Over the past 34 years Pro Co Sound has perfected distortion pedals. The You Dirty Rat is an example of that perfection. With its silky smooth variable distortion, filter and volume adjustments your sound can easily be customized with acute accuracy. The You Dirty Rats true bypass switching eliminates the loading effect common with other devices.

Durability is enhanced with its P.C. board made of mil-spec epoxy glass for extreme shock resistance and a heavy-duty industrial grade footswitch all housed in Pro Co's rugged sloped-faced steel chassis. Also standard is Pro Co's simple to use, no tools required battery compartment.

TRAT Suggested Resale \$129.98

RPS1 (Bat elim.) Suggested Resale \$16.99

Rats

Deucetone RAT

The newest addition to the Rat family is the Deucetone *Rat*. Originally designed as the R2DU (Rat 2 Distortion Unit), a rack effect with a dual foot switch, the Deucetone *Rat* brings the R2DU out of the rack and onto the floor and the spirit of the R2DU lives on in two independent rat units that can be used separately or together. Selectable diodes produce a variable sonic palette utilizing the tones from the Vintage Rat, TurboRAT and two never before heard rat sounds — the Clean and Dirty rats.



The Deucetone *Rat* has all the classic features of the “rackrat” including two independent rat circuits, providing true stereo capability or the ability to cascade one side into the other for best bone-crushing rat sound yet.

The Deucetone *Rat* is housed in a new compact sloped-face pedal-only design. New triple-pole foot switches have been added for greater reliability and the switches have been strategically placed to allow for easy stomping of both channels simultaneously. Like the rest of the rat family, the Deucetone *Rat* is housed in an indestructible steel enclosure that will provide years of on-the-road reliability.

The Deucetone *Rat* offers two channels of raw distortion providing the ability to change, on the fly, between three different settings per side — that is six rats in one. The germanium diodes that drive the dirty rat give this rat by far, the most incredible sound ever.

What makes this pedal so powerful is the ability of the guitarist to run both channels independently of one another or in a cascade mode to deliver a combination of the two rats.

From a double dose of vintage rats to a dirty rat/clean boost combination, you are sure to find the perfect sound to take that great guitar lead to the next level. If you are like a lot of guitarists today, you are probably rethinking your rackmount effects and are heading back to floor units. The Deucetone *Rat* will bring your multi-distortion needs back to ground level while taking the sound of your rig to new heights. It is the most incredible stompbox on the planet.

DeucetoneRAT Suggested Resale \$249.99

RPS1 (Bat elim.) Suggested Resale \$16.99

Juggernaut Bass Rat

At last, there is a Rat designed specifically for bass players. The Pro Co Juggernaut Bass Rat stomp box gives bass players the ability to adjustably blend all of the crunch and power of the world’s greatest distortion pedal with the natural tonality of the bass itself. Slap bass players and bass soloists will be in “lead” heaven.



For 25 years, discerning guitarists have used the Rat’s “magic” sound, its perfect blend of distortion, sustain and cutting power, usually found only at a volume too loud for club and studio work. Now, bass players can get the same radically different sound in a unit designed specifically for them.

The Juggernaut provides three useful functions for the performing musician: first, a warm, “tube-y” distortion unit; second, the ability to mix the distortion with direct sound to retain “punch;” and third, an effects loop for external processing devices, allowing the blending of an externally-processed signal with the original signal, with or without the addition of distortion to the external effect. As an example of the versatility of this last feature, the Juggernaut allows a bass guitarist to utilize an ordinary wah-wah pedal in its effects loop to result in a wah-wah bass sound that retains the full fundamental impact of the bass guitar. The same benefit is evident when used with flangers or phasers.

Smooth, continuously variable controls for distortion amount, filter cutoff and volume level let you preset just the right degree of overdrive, tune in on the presence without any tinny treble, and balance the output for that perfect extra boost. The Juggernaut has two LED indicator lights that make the on/off status ease-to-see, with knob indicators provided for added visibility.

There is a master volume pot provided to control overall output level.

The sloped-front Juggernaut is housed in the same massive virtually indestructible steel enclosure as the Deucetone Rat. Although the unit can be operated using an internal 9v battery (not provided), it is suggested that an outboard RPS1 Rat power supply be used because of its significant current drain.

FYI, about 25 Juggernauts were built in the 80’s for friends of the company. Larry Graham of Graham Central Station and Sly and the Family Stone fame used one of the original units. He started slap bass. The Juggernaut was there when he did; it was part of the sound.

JRAT Suggested Resale \$249.99

RPS1 (Bat elim.) Suggested Resale \$16.99

Plateworks™ Standard Wallplates

Single through Three Gang

Brushed Stainless Steel 430 Alloy (302 Alloy used for Engraved Plates). **One Punch-Out per Gang - Punch-Out will be centered within the Gang. More than one Punch-Out per Gang - Punch-Out hole centers will be adjusted to allow for markers.** Lamacoid marking available — refer to Lamacoid marker section for details.

Blank & Punched Only Wallplates

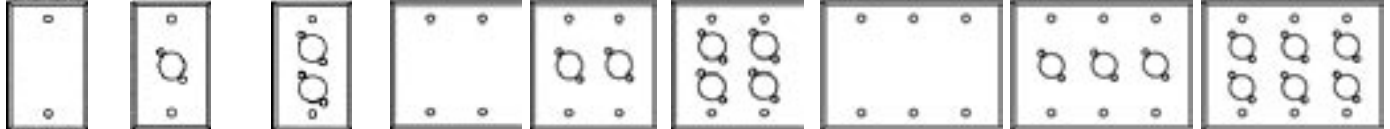

WP 1000 Blank, Single Gang
WPU 1004 Single Gang w/ (2) "D-Series" Punch Out
WPU 1013 Single Gang w/ (2) "D-Series" Punch Out
WP 2000 Blank, Dual Gang
WPU 2009 Dual Gang w/ (2) "D-Series" Punch Out
WPU 2011 Dual Gang w/ (4) "D-Series" Punch Out
WP 3000 Blank, Triple Gang
WPU 3001 Triple Gang w/ (3) "D-Series" Punch Out
WPU 3002 Triple Gang w/ (6) "D-Series" Punch Out

1-3 Gang Loaded with Female XLRs



WP 1004
 (1) Neutrik NC3FDL-1 "D-Series" 3 Cond. Latching Female XLR

With Engraving ENGRAVING OPTIONS

Model #	Engraving	Model #	Engraving
WPE 109	MIC 1	WPE 121	MIC 13
WPE 110	MIC 2	WPE 122	MIC 14
WPE 111	MIC 3	WPE 123	MIC 15
WPE 112	MIC 4	WPE 124	MIC 16
WPE 113	MIC 5	WPE 125	MIC 17
WPE 114	MIC 6	WPE 126	MIC 18
WPE 115	MIC 7	WPE 127	MIC 19
WPE 116	MIC 8	WPE 128	MIC 20
WPE 117	MIC 9	WPE 129	MIC 21
WPE 118	MIC 10	WPE 130	MIC 22
WPE 119	MIC 11	WPE 131	MIC 23
WPE 120	MIC 12	WPE 132	MIC 24

Panel Mount Female XLR Connectors
NC3FDL-1 - Female XLR-type, "D-Series," nickel shell, silver contacts, locking latch
NC3FDL-1-0 - As NC3FDL-1, retention spring instead of locking latch
NC3FP-P - As NC3FDL-1, glass-filled polyester shell

Mating Cable Mount XLR Connectors
NC3MX - Male XLR-type, screwless, nickel shell, silver contacts, chuck-type strain relief
NC3MX-BAG - As NC3MX, black shell, silver contacts
NC3MX-B - As NC3MX, black shell, gold contacts

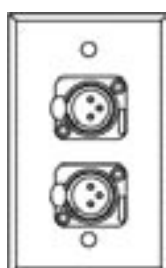

WP 1013
 (2) Neutrik NC3FDL-1 "D-Series" 3 Cond. Latching Female XLR

With Engraving

Model #	Engraving
WPE 101	MIC 1-2
WPE 102	MIC 3-4
WPE 103	MIC 5-6
WPE 104	MIC 7-8
WPE 105	MIC 9-10
WPE 106	MIC 11-12
WPE 107	MIC 13-14
WPE 108	MIC 15-16

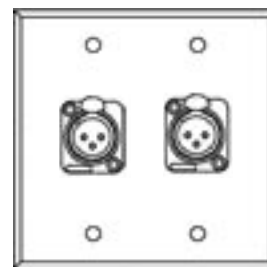

WP 2034
 (2) Neutrik NC3FDL-1 "D-Series" 3 Cond. Latching Female XLR

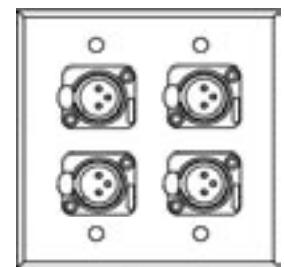

WP 2035
 (4) Neutrik NC3FDL-1 "D-Series" 3 Cond. Latching Female XLR

With Engraving ENGRAVING OPTIONS

Model #	Engraving
WPE 201	MIC 1-4
WPE 202	MIC 5-8
WPE 203	MIC 9-12
WPE 204	MIC 13-16
WPE 205	MIC 17-20
WPE 206	MIC 21-24

WPE 201
 (4) Neutrik NC3FDL-1 "D-Series" 3 Cond. Latching Female XLR

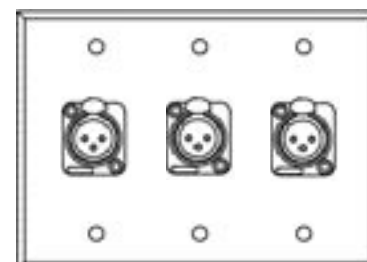

WP 3001
 (3) Neutrik NC3FDL-1 "D-Series" 3 Cond. Latching Female XLR

Plateworks™ Standard Wallplates

1-3 Gang Loaded with Female XLRs (continued)

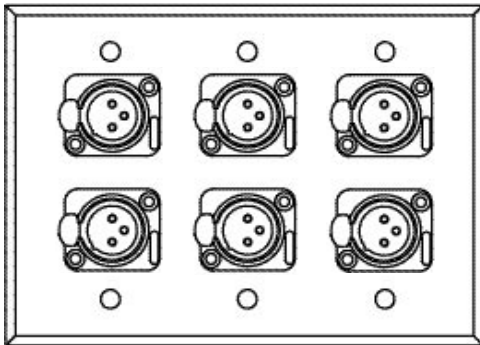

WP 3002
(6) Neutrik NC3FDL-1
"D-Series" 3 Cond. Latching Female XLR

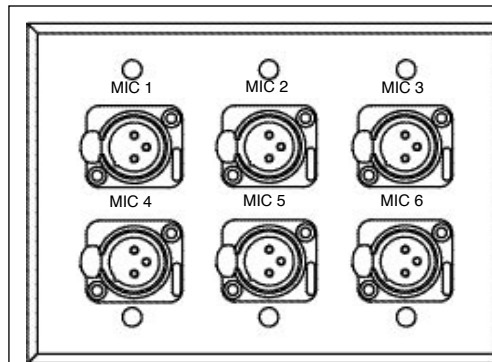

WPE 301
(6) Neutrik NC3FDL-1
"D-Series" 3 Cond. Latching Female XLR

With Engraving ENGRAVING OPTIONS

Model #	Engraving
WPE 301	MIC 1-6
WPE 302	MIC 7-12
WPE 303	MIC 13-18
WPE 304	MIC 19-24



WP 1042
(1) Neutrik NC3FDL-1-0
"D-Series" 3 Cond.
Latchless Female XLR

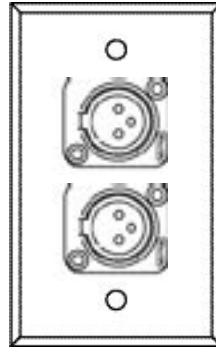

WP 1043
(2) Neutrik NC3FDL-1-0
"D-Series" 3 Cond.
Latchless Female XLR

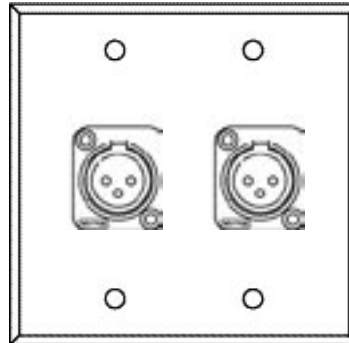

WP 2009
(2) Neutrik NC3FDL-1-0
"D-Series" 3 Cond.
Latchless Female XLR

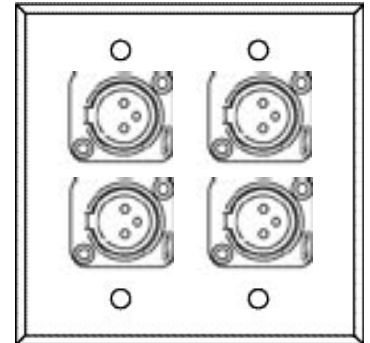

WP 2011
(4) Neutrik NC3FDL-1-0
"D-Series" 3 Cond.
Latchless Female XLR

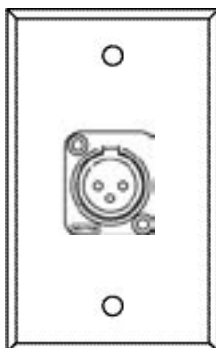

WP 1025
(1) Neutrik NC3FP-P
"D-Series" 3 Cond.
Latchless Plastic Female
XLR

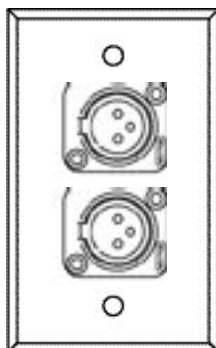

WP 1026
(2) Neutrik NC3FP-P
"D-Series" 3 Cond.
Latchless Plastic
Female XLR

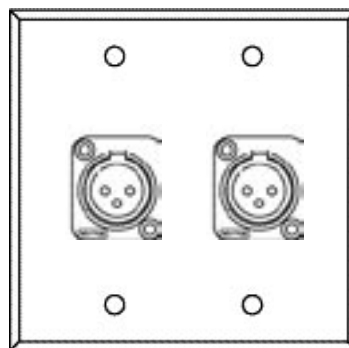

WP 2015
(2) Neutrik NC3FP-P
"D-Series" 3 Cond.
Latchless Plastic Female XLR

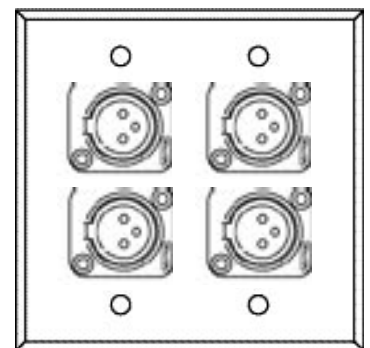

WP 2017
(4) Neutrik NC3FP-P
"D-Series" 3 Cond.
Latchless Plastic Female XLR

Plateworks™ Standard Wallplates

1-3 Gang Loaded with Male XLRs



WP 1014
(1) Neutrik NC3MDL-1
"D-Series" 3 Cond.
Male XLR

**With Engraving
ENGRAVING OPTIONS**

Model #	Engraving
WPE 153	LINE OUT 1
WPE 154	LINE OUT 2
WPE 155	LINE OUT 3
WPE 156	LINE OUT 4
WPE 157	LINE OUT 5
WPE 158	LINE OUT 6
WPE 159	LINE OUT 7
WPE 160	LINE OUT 8

WPE 153
(1) Neutrik NC3MDL-1
"D-Series" 3 Cond.
Male XLR

Panel Mount Male XLR Connectors



NC3MDL-1 - Male XLR-type, "D-Series," nickel shell, silver contacts, locking latch

NC3MDL-1-0 - As NC3FDL-1, retention spring instead of locking latch

NC3MP-P - As NC3FDL-1, glass-filled polyester shell

Mating Cable Mount XLR Connectors



NC3FX - Female XLR-type, screwless, nickel shell, silver contacts, chuck-type strain relief

NC3FX-BAG - As NC3FX, black shell, silver contacts

NC3FX-B - As NC3FX, black shell, gold contacts

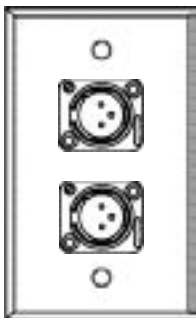

WP 1008
(2) Neutrik NC3MDL-1
"D-Series" 3 Cond.
Male XLR

**With Engraving
ENGRAVING OPTIONS**

Model #	Engraving
WPE 161	LINE OUT 1-2
WPE 162	LINE OUT 3-4
WPE 163	LINE OUT 5-6
WPE 164	LINE OUT 7-8
WPE 183	INTERCOM A-B
WPE 184	INTERCOM C-D

WPE 161
(2) Neutrik NC3MDL-1
"D-Series" 3 Cond.
Male XLR

WPE 183
(2) Neutrik NC3MDL-1
"D-Series" 3 Cond.
Male XLR

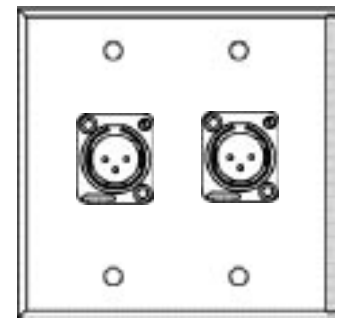

WP 2010
(2) Neutrik NC3MDL-1
"D-Series" 3 Cond. Male XLR

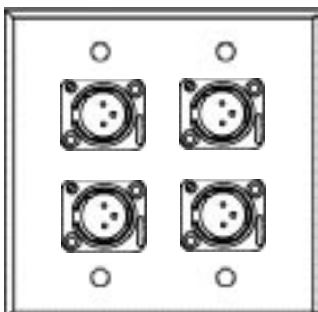

WP 2012
(4) Neutrik NC3MDL-1
"D-Series" 3 Cond. Male XLR

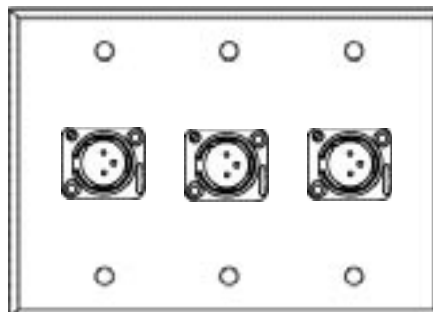

WP 3003
(3) Neutrik NC3MDL-1
"D-Series" 3 Cond. Male XLR

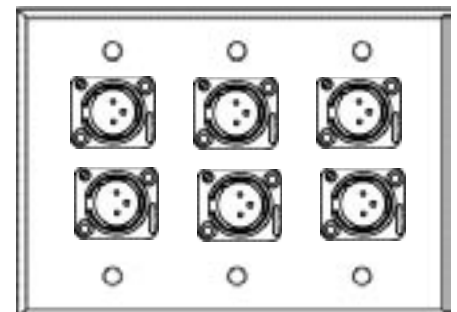

WP 3004
(6) Neutrik NC3MDL-1
"D-Series" 3 Cond. Male XLR

Plateworks™ Standard Wallplates

1-3 Gang Loaded with Male XLRs (continued)



WP 1027
(1) Neutrik NC3MP-P
"D-Series" 3 Cond.
Plastic Male XLR



WP 1028
(2) Neutrik NC3MP-P
"D-Series" 3 Cond. Plastic
Male XLR

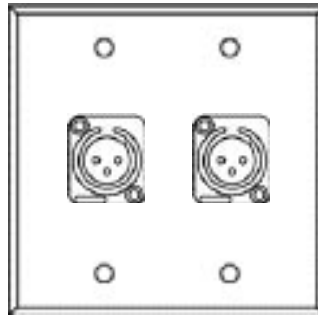

WP 2016
(2) Neutrik NC3MP-P
"D-Series" 3 Cond.
Plastic Male XLR

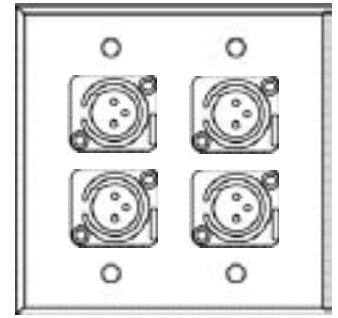

WP 2018
(4) Neutrik NC3MP-P
"D-Series" 3 Cond.
Plastic Male XLR

1-2 Gang Loaded with 3-Conductor 1/4" Phone Jacks



WP 1017
(1) L12-B
3 Cond. (Open) 1/4"
Phone Jack w/Isolation
Washers



WP 1018
(2) L12-B
3 Cond. (Open) 1/4"
Phone Jack w/Isolation
Washers

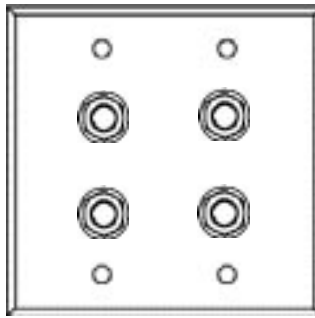

WP 2024
(4) L12-B
3 Cond. (Open) 1/4" Phone Jack
w/Isolation Washers

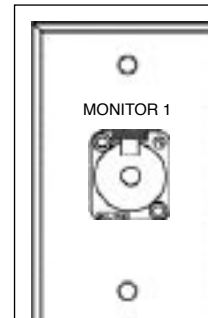

WPE 171
(1) Neutrik NJ3FP-6C
"D-Series" Latching
3 Cond. (Open) 1/4"
Phone Jack

With Engraving ENGRAVING OPTIONS

Model #	Engraving
WPE 171	MONITOR 1
WPE 172	MONITOR 2
WPE 173	MONITOR 3
WPE 174	MONITOR 4
WPE 175	MONITOR 5
WPE 176	MONITOR 6
WPE 177	MONITOR 7
WPE 178	MONITOR 8

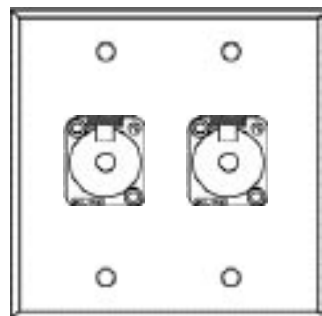

WP 2021
(2) Neutrik NJ3FP-6C
"D-Series" Latching 3 Cond. (Open)
1/4" Phone Jack

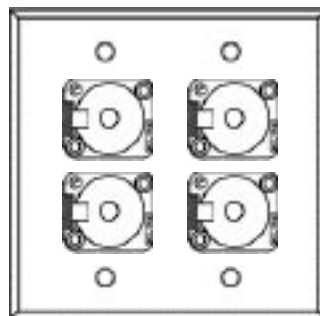

WP 2023
(4) Neutrik NJ3FP-6C
"D-Series" Latching 3 Cond. (Open)
1/4" Phone Jack

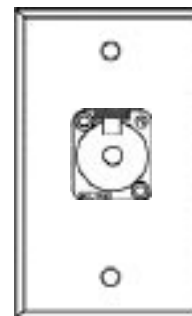

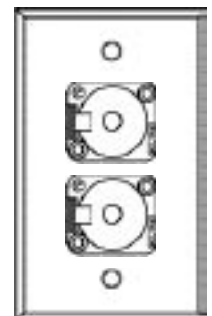

WP 1006
(1) Neutrik NJ3FP-6C
"D-Series" Latching
3 Cond. (Open) 1/4"
Phone Jack





WP 1007
(2) Neutrik NJ3FP-6C
"D-Series" Latching 3
Cond. (Open) 1/4" Phone
Jack

Panel Mount TRS Connectors

-  **L12-B** - 1/4" phone jack, 3 Cond., open circuit, iso washers
-  **NJ3FP-6C** - 1/4" phone jack, locking latch, "D-Series" configuration, 3 silver contacts

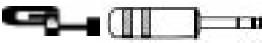
Mating Cable Mount TRS Connectors

-  **BF3P** - 1/4" ShowSavers™ phone plug, T/R/S, copper tip
-  **NP3C** - 1/4" phone plug, T/R/S, w/chuck strain relief

Plateworks™ Standard Wallplates

1-2 Gang Loaded with Neutrik™ Speakons



WP 1009
(1) Neutrik NL4MP
"D-Series" 4 Cond.
Speakon



WPE 135
(1) Neutrik NL4MP
"D-Series" 4 Cond.
Speakon

With Engraving ENGRAVING OPTIONS

Model #	Engraving
WPE 135	SPEAKER 1
WPE 136	SPEAKER 2
WPE 137	SPEAKER 3
WPE 138	SPEAKER 4
WPE 139	SPEAKER 5
WPE 140	SPEAKER 6
WPE 141	SPEAKER 7
WPE 142	SPEAKER 8
WPE 143	SPEAKER 9
WPE 144	SPEAKER 10
WPE 145	SPEAKER 11
WPE 146	SPEAKER 12

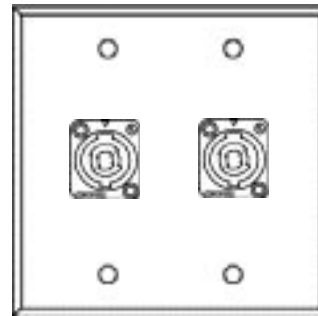

WP 2032
(2) Neutrik NL4MP "D-Series"
4 Cond. Speakon

Panel Mount Speakon Connectors



NL4AMP - Speakon, Male panel-mount, "D-Series" configuration, 4 silver contacts for speakers

Mating Cable Mount Speakon Connectors



NL4FC/NL4FX - Speakon, Female cable-mount, 4 silver contacts for speakers

NL2FC - Speakon, Female cable-mount, 2 silver contacts for speakers

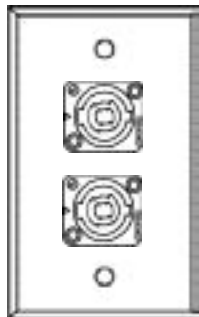

WP 1010
(2) Neutrik NL4MP
"D-Series" 4 Cond.
Speakon

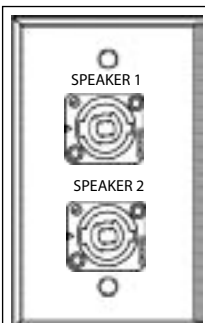

WPE 147
(2) Neutrik
NL4MP "D-Series"
4 Cond. Speakon

With Engraving ENGRAVING OPTIONS

Model #	Engraving
WPE 147	SPEAKER 1-2
WPE 148	SPEAKER 3-4
WPE 149	SPEAKER 5-6
WPE 150	SPEAKER 7-8
WPE 151	SPEAKER 9-10
WPE 152	SPEAKER 11-12

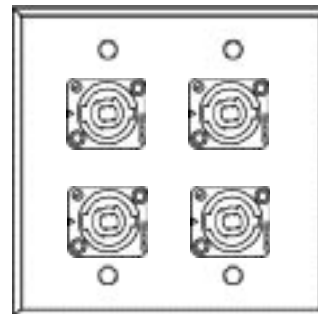

WP 2033
(4) Neutrik NL4MP "D-Series"
4 Cond. Speakon

1 Gang Loaded with RCA Jack(s)



WP 1012
(1) 3501-FR "RCA" Type
Phono Jack



WP 1021
(2) 3501-FR "RCA" Type
Phono Jack

Panel Mount RCA Connectors



3505FR - RCA, Female panel-mount jack, w/ isolation washers

Mating Cable Mount RCA Connectors



3502HD - RCA, Male cable-mount, nickel contacts, Heavy Duty

1-2 Gang Loaded with Female XLR and 3-Cond. Phone Jacks

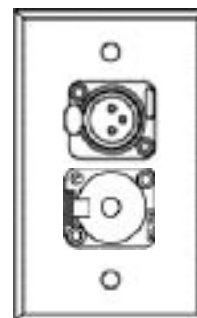

WP 1055
(1) Neutrik NC3FDL-1
Latching Female XLR
(1) Neutrik NJ3FP-6C
Latching 3 Cond.
(Open) 1/4"

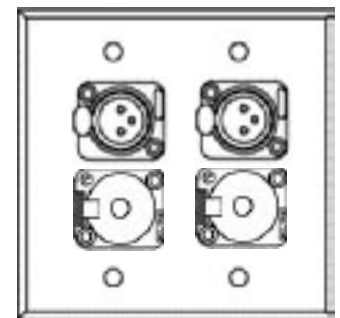

WP 2040
(2) Neutrik NC3FDL-1 Latching Female
XLR (2) Neutrik NJ3FP-6C Latching 3
Cond. (Open) 1/4"

Plateworks™ Standard Wallplates

1-3 Gang Loaded with Male XLRs (continued)



WP 1027
(1) Neutrik NC3MP-P
"D-Series" 3 Cond.
Plastic Male XLR



WP 1028
(2) Neutrik NC3MP-P
"D-Series" 3 Cond. Plastic
Male XLR

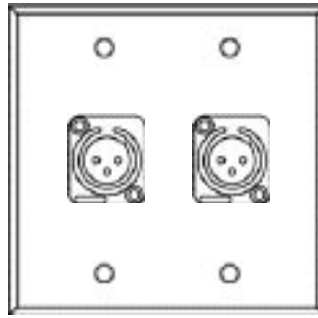

WP 2016
(2) Neutrik NC3MP-P
"D-Series" 3 Cond.
Plastic Male XLR

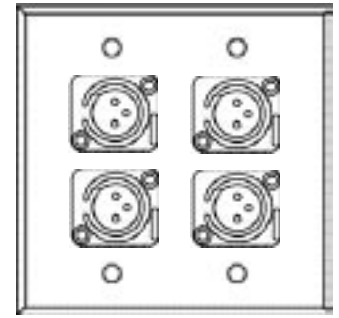

WP 2018
(4) Neutrik NC3MP-P
"D-Series" 3 Cond.
Plastic Male XLR

1-2 Gang Loaded with 3-Conductor 1/4" Phone Jacks



WP 1017
(1) L12-B
3 Cond. (Open) 1/4"
Phone Jack w/Isolation
Washers



WP 1018
(2) L12-B
3 Cond. (Open) 1/4"
Phone Jack w/Isolation
Washers

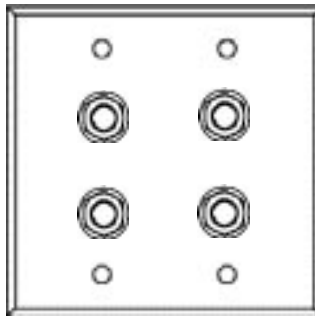

WP 2024
(4) L12-B
3 Cond. (Open) 1/4" Phone Jack
w/Isolation Washers

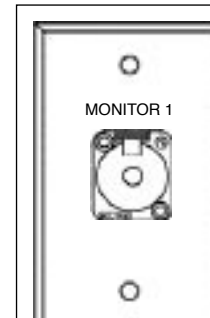

WPE 171
(1) Neutrik NJ3FP-6C
"D-Series" Latching
3 Cond. (Open) 1/4"
Phone Jack

With Engraving ENGRAVING OPTIONS

Model #	Engraving
WPE 171	MONITOR 1
WPE 172	MONITOR 2
WPE 173	MONITOR 3
WPE 174	MONITOR 4
WPE 175	MONITOR 5
WPE 176	MONITOR 6
WPE 177	MONITOR 7
WPE 178	MONITOR 8

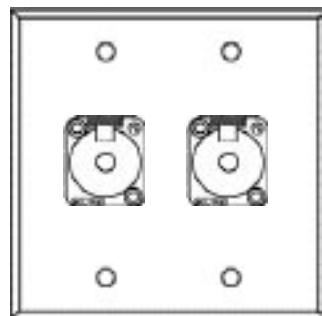

WP 2021
(2) Neutrik NJ3FP-6C
"D-Series" Latching 3 Cond. (Open)
1/4" Phone Jack

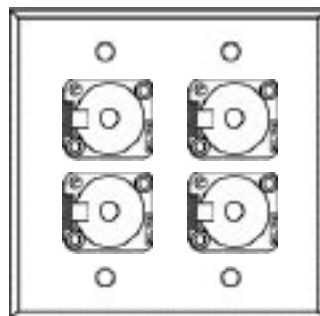

WP 2023
(4) Neutrik NJ3FP-6C
"D-Series" Latching 3 Cond. (Open)
1/4" Phone Jack

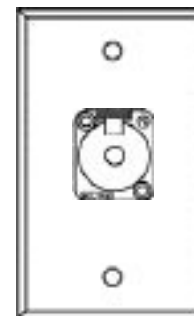

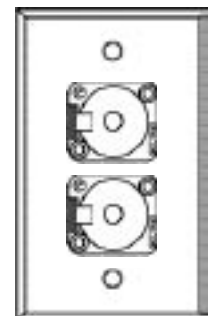

WP 1006
(1) Neutrik NJ3FP-6C
"D-Series" Latching
3 Cond. (Open) 1/4"
Phone Jack





WP 1007
(2) Neutrik NJ3FP-6C
"D-Series" Latching 3
Cond. (Open) 1/4" Phone
Jack

Panel Mount TRS Connectors

-  **L12-B** - 1/4" phone jack, 3 Cond., open circuit, iso washers
-  **NJ3FP-6C** - 1/4" phone jack, locking latch, "D-Series" configuration, 3 silver contacts

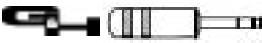
Mating Cable Mount TRS Connectors

-  **BF3P** - 1/4" ShowSavers™ phone plug, T/R/S, copper tip
-  **NP3C** - 1/4" phone plug, T/R/S, w/chuck strain relief

Plateworks™ Standard Wallplates

1-2 Gang Loaded with Neutrik™ Speakons



WP 1009
(1) Neutrik NL4MP
"D-Series" 4 Cond.
Speakon



WPE 135
(1) Neutrik NL4MP
"D-Series" 4 Cond.
Speakon

With Engraving ENGRAVING OPTIONS

Model #	Engraving
WPE 135	SPEAKER 1
WPE 136	SPEAKER 2
WPE 137	SPEAKER 3
WPE 138	SPEAKER 4
WPE 139	SPEAKER 5
WPE 140	SPEAKER 6
WPE 141	SPEAKER 7
WPE 142	SPEAKER 8
WPE 143	SPEAKER 9
WPE 144	SPEAKER 10
WPE 145	SPEAKER 11
WPE 146	SPEAKER 12

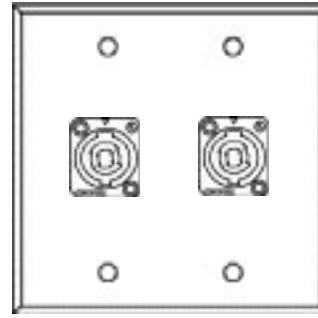

WP 2032
(2) Neutrik NL4MP "D-Series"
4 Cond. Speakon

Panel Mount Speakon Connectors



NL4AMP - Speakon, Male panel-mount, "D-Series" configuration, 4 silver contacts for speakers

Mating Cable Mount Speakon Connectors



NL4FC/NL4FX - Speakon, Female cable-mount, 4 silver contacts for speakers

NL2FC - Speakon, Female cable-mount, 2 silver contacts for speakers

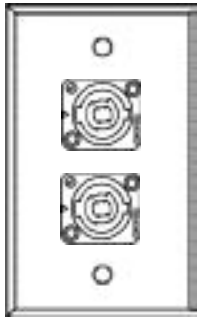

WP 1010
(2) Neutrik NL4MP
"D-Series" 4 Cond.
Speakon

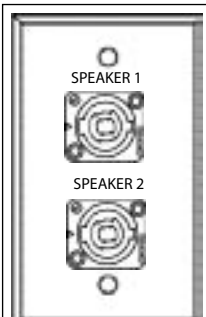

WPE 147
(2) Neutrik
NL4MP "D-Series"
4 Cond. Speakon

With Engraving ENGRAVING OPTIONS

Model #	Engraving
WPE 147	SPEAKER 1-2
WPE 148	SPEAKER 3-4
WPE 149	SPEAKER 5-6
WPE 150	SPEAKER 7-8
WPE 151	SPEAKER 9-10
WPE 152	SPEAKER 11-12

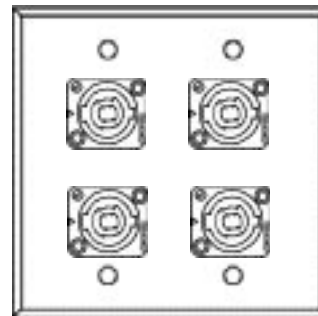

WP 2033
(4) Neutrik NL4MP "D-Series"
4 Cond. Speakon

1 Gang Loaded with RCA Jack(s)



WP 1012
(1) 3501-FR "RCA" Type
Phono Jack



WP 1021
(2) 3501-FR "RCA" Type
Phono Jack

Panel Mount RCA Connectors



3505FR - RCA, Female panel-mount jack, w/ isolation washers

Mating Cable Mount RCA Connectors



3502HD - RCA, Male cable-mount, nickel contacts, Heavy Duty

1-2 Gang Loaded with Female XLR and 3-Cond. Phone Jacks

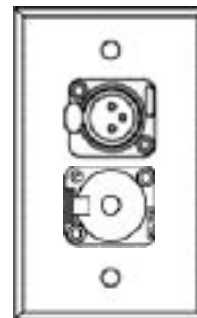

WP 1055
(1) Neutrik NC3FDL-1
Latching Female XLR
(1) Neutrik NJ3FP-6C
Latching 3 Cond.
(Open) 1/4"

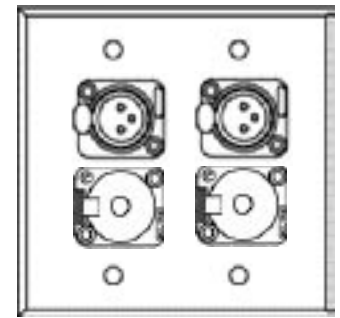

WP 2040
(2) Neutrik NC3FDL-1 Latching Female
XLR (2) Neutrik NJ3FP-6C Latching 3
Cond. (Open) 1/4"

Plateworks™ Standard Wallplates

1-2 Gang Loaded with BNC Connectors

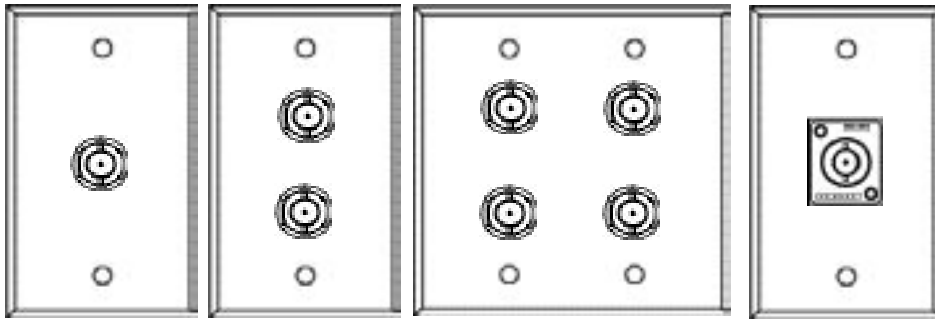

WP 1019
(1) BCJ-JR Canare
BNC Feedthru

WP 1020
(2) BCJ-JR Canare
BNC Feedthru

WP 2036
(4) BCJ-JR Canare
BNC Feedthru

WP 1039
(1) BCJ-JRU Canare
Flushmount BNC
Feedthru

Panel Mount BNC Connectors



NBB75FI - Neutrik BNC feedthru panel jack with IU-7/16 isolation gasket



NBB75FDI - Neutrik flushmount BNC feedthru panel jack

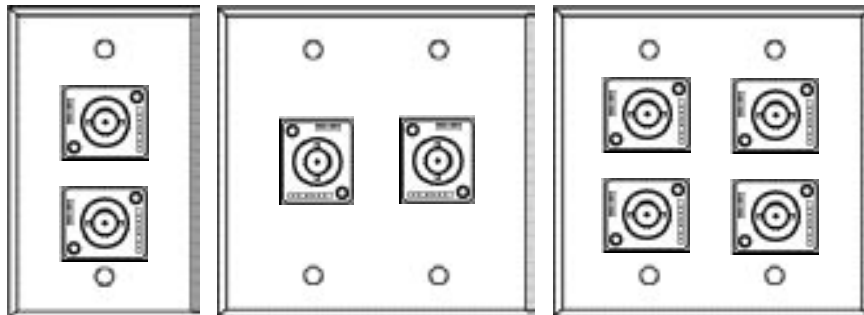
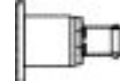

WP 1040
(2) BCJ-JRU Canare
Flushmount BNC
Feedthru

WP 2028
(2) BCJ-JRU Canare
Flushmount BNC Feedthru

WP 2030
(4) BCJ-JRU Canare
Flushmount BNC Feedthru

1 Gang Loaded with 5-pin XLR Connectors (DMX)

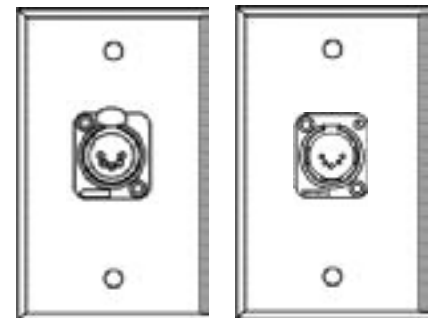

WP 1049
(1) Neutrik NC5FDL-1
"D-Series" 5 Cond. Latching Female XLR

WP 1050
(1) Neutrik NC5MDL-1
"D-Series" 5 Cond. Male XLR

1-2 Gang Loaded with F-Type Connectors

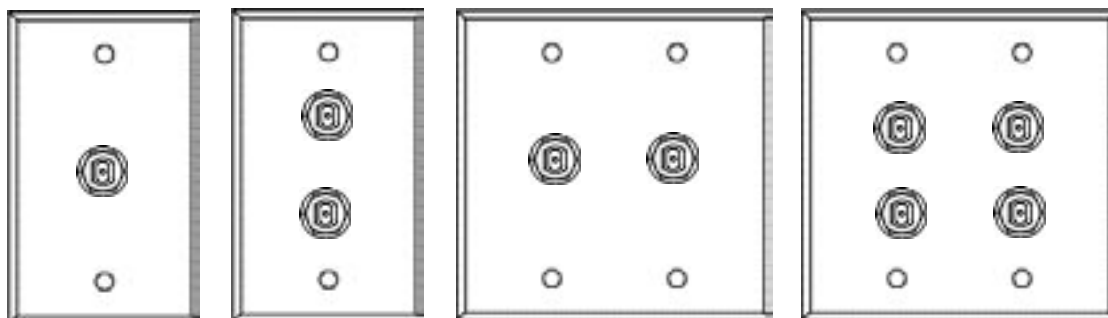

WP 1015
(1) Blonder-Tongue
GF81C "F-Type"
Coaxial Feedthru

WP 1016
(2) Blonder-Tongue
GF81C "F-Type"
Coaxial Feedthru

WP 2027
(2) Blonder-Tongue GF81C
"F-Type" Coaxial Feedthru

WP 2029
(4) Blonder-Tongue GF81C
"F-Type" Coaxial Feedthru

Panel Mount "F-Type" Connectors



GF81C - Blonder-Tongue "F" connector, feedthru, iso washers

Logo Panels LP1

Logo Panels add professionalism to every rack in every installation. Send us any artwork in nearly any program and we will laser engrave your personalized artwork/message on a 19" single rack space black anodized aluminum panel.



Single-gang Wallplates - Connectors Loaded, No Engraving

Model Number	Page No.	Connector Qty.	Connector Description	Suggested Resale
WP1004	38	1	Neutrik NC3FDL-1 Latching "D-Series" female XLR	\$9.49
WP1006	41	1	Neutrik NJ3FP6-C "D-Series" locking 1/4" jack	\$12.99
WP1007	41	2	Neutrik NJ3FP6-C "D-Series" locking 1/4" jack	\$23.99
WP1008	40	2	Neutrik NC3MDL-1 "D-Series" male XLR	\$16.49
WP1009	42	2	Neutrik NL4MP "D-Series" 4 Cond. Speakon	\$9.49
WP1010	42	2	Neutrik NL4MP "D-Series" 4 Cond. Speakon	\$16.99
WP1012	42	1	3501 FR RCA phone jack	\$9.99
WP1013	38	2	Neutrik NC3FDL-1 Latching "D-Series" female XLR	\$16.99
WP1014	42	1	Neutrik NC3MDL-1 "D-Series" male XLR	\$9.49
WP1015	43	1	Blonder-Tongue GF81C Feed thru coaxial connector	\$9.99
WP1016	43	2	Blonder-Tongue GF81C Feed thru coaxial connector	\$15.49
WP1017	41	1	L12-B 3 Cond. (open) 1/4" phone jack with Isolation washer	\$9.99
WP1018	41	2	L12-B 3 Cond. (open) 1/4" phone jack with Isolation washer	\$17.49
WP1019	43	1	Canare BCJ-JR BNC Feedthru, isolation washer	\$13.49
WP1020	43	2	Canare BCJ-JR BNC Feedthru, isolation washer	\$24.99
WP1021	42	2	3501 FR RCA phone jack	\$17.49
WP1025	39	1	Neutrik NC3FP-P "D-Series" female XLR	\$7.49
WP1026	39	2	Neutrik NC3FP-P "D-Series" female XLR	\$12.49
WP1027	41	1	Neutrik NC3MP-P "D-Series" male XLR	\$7.49
WP1028	41	2	Neutrik NC3MP-P "D-Series" male XLR	\$12.49
WP1039	43	1	Canare BCJ-JRU Flushmount BNC Feedthru	\$21.99
WP1040	43	2	Canare BCJ-JRU Flushmount BNC Feedthru	\$41.99
WP1042	39	1	Neutrik NC3FDL-1-O "D-Series" non-latching female XLR	\$9.49
WP1043	39	2	Neutrik NC3FDL-1-O "D-Series" non-latching female XLR	\$16.99
WP1049	43	1	Neutrik NC5FDL-1 "D-Series" 5-pin female XLR for DMX	\$18.49
WP1050	43	1	Neutrik NC5MDL-1 "D-Series" 5-pin male XLR for DMX	\$15.49
WP1055	43	2	Neutrik NC3FDL-1 and NJ3FP6C	\$11.99

Two-gang Wallplates

WP2009	39	2	Neutrik NC3FDL-1-O "D-Series" female XLR	\$20.49
WP2010	38	2	Neutrik NC3MDL-1 "D-Series" male XLR	\$19.99
WP2011	39	4	Neutrik NC3FDL-1-O "D-Series" female XLR	\$35.49
WP2012	38	4	Neutrik NC3MDL-1 "D-Series" male XLR	\$34.99
WP2015	38	2	Neutrik NC3FP-P "D-Series" female XLR	\$16.49
WP2016	41	2	Neutrik NC3MP-P "D-Series" male XLR	\$15.99
WP2017	38	4	Neutrik NC3FP-P "D-Series" female XLR	\$25.99
WP2018	41	4	Neutrik NC3MP-P "D-Series" male XLR	\$25.99
WP2021	41	2	Neutrik NJ3FP6-C "D-Series" 1/4" locking phone jack	\$27.49
WP2023	41	4	Neutrik NJ3FP6-C "D-Series" 1/4" locking phone jack	\$48.99
WP2024	41	4	N-112B 3 Cond. 1/4" phone jack	\$35.99
WP2027	43	2	Blonder-Tongue GF81C Feedthru coaxial connector	\$20.99
WP2028	43	2	Canare BCJ-JRU Flushmount BNC Feedthru	\$45.49
WP2029	43	4	Blonder-Tongue GF81C Feedthru coaxial connector	\$36.49
WP2030	43	4	Canare BCJ-JRU Flushmount BNC Feedthru	\$85.49
WP2032	42	2	Neutrik NL4MP "D-Series" 4 Cond. Speakon	\$20.49
WP2033	42	4	Neutrik NL4MP "D-Series" 4 Cond. Speakon	\$34.99
WP2034	38	2	Neutrik NC3FDL-1 "D-Series" 3 Cond. Latching female XLR	\$20.49
WP2035	38	4	Neutrik NC3FDL-1 "D-Series" 3 Cond. Latching female XLR	\$35.49
WP2036	43	4	Canare BCJ-JR BNC Feedthru, Isolation washer	\$80.99
WP2040	42	(2)(2)	(2) Neutrik NC3FDL-1 female XLR (2) Neutrik NC3FP6-C Locking 1/4"	\$41.99

Three-gang Wallplates

WP3001	38	3	Neutrik NC3FDL-1 "D-Series" 3 Cond. Latching female XLR	\$31.49
WP3002	39	6	Neutrik NC3FDL-1 "D-Series" 3 Cond. Latching female XLR	\$52.49
WP3003	40	3	Neutrik NC3MDL-1 "D-Series" 3 Cond. male XLR	\$30.49
WP3004	40	6	Neutrik NC3MDL-1 "D-Series" 3 Cond. male XLR	\$52.49

NOTE: All Standard Wallplates are brushed 430 stainless steel. These wallplates are pre-assembled with rivets.

All connectors are panel isolated.

Pricing and Specifications Subject to Change without Notice.

Single-gang Wallplates - Loaded and Engraved

Model Number	Page No.	Connector Qty.	Connector Description	Suggested Resale
WPE 101	38	2	Neutrik NC3FDL-1 Latching "D-Series" female XLR	\$20.99
WPE 102	38	2	Neutrik NC3FDL-1 Latching "D-Series" female XLR	\$20.99
WPE 103	38	2	Neutrik NC3FDL-1 Latching "D-Series" female XLR	\$20.99
WPE 104	38	2	Neutrik NC3FDL-1 Latching "D-Series" female XLR	\$20.99
WPE 105	38	2	Neutrik NC3FDL-1 Latching "D-Series" female XLR	\$20.99
WPE 106	38	2	Neutrik NC3FDL-1 Latching "D-Series" female XLR	\$20.99
WPE 107	38	2	Neutrik NC3FDL-1 Latching "D-Series" female XLR	\$20.99
WPE 108	38	2	Neutrik NC3FDL-1 Latching "D-Series" female XLR	\$20.99
WPE 109	38	1	Neutrik NC3FDL-1 Latching "D-Series" female XLR	\$11.99
WPE 110	38	1	Neutrik NC3FDL-1 Latching "D-Series" female XLR	\$11.99
WPE 111	38	1	Neutrik NC3FDL-1 Latching "D-Series" female XLR	\$11.99
WPE 112	38	1	Neutrik NC3FDL-1 Latching "D-Series" female XLR	\$11.99
WPE 113	38	1	Neutrik NC3FDL-1 Latching "D-Series" female XLR	\$11.99
WPE 114	38	1	Neutrik NC3FDL-1 Latching "D-Series" female XLR	\$11.99
WPE 115	38	1	Neutrik NC3FDL-1 Latching "D-Series" female XLR	\$11.99
WPE 116	38	1	Neutrik NC3FDL-1 Latching "D-Series" female XLR	\$11.99
WPE 117	38	1	Neutrik NC3FDL-1 Latching "D-Series" female XLR	\$11.99
WPE 118	38	1	Neutrik NC3FDL-1 Latching "D-Series" female XLR	\$11.99
WPE 119	38	1	Neutrik NC3FDL-1 Latching "D-Series" female XLR	\$11.99
WPE 120	38	1	Neutrik NC3FDL-1 Latching "D-Series" female XLR	\$11.99
WPE 121	38	1	Neutrik NC3FDL-1 Latching "D-Series" female XLR	\$11.99
WPE 122	38	1	Neutrik NC3FDL-1 Latching "D-Series" female XLR	\$11.99
WPE 123	38	1	Neutrik NC3FDL-1 Latching "D-Series" female XLR	\$11.99
WPE 124	38	1	Neutrik NC3FDL-1 Latching "D-Series" female XLR	\$11.99
WPE 125	38	1	Neutrik NC3FDL-1 Latching "D-Series" female XLR	\$11.99
WPE 126	38	1	Neutrik NC3FDL-1 Latching "D-Series" female XLR	\$11.99
WPE 127	38	1	Neutrik NC3FDL-1 Latching "D-Series" female XLR	\$11.99
WPE 128	38	1	Neutrik NC3FDL-1 Latching "D-Series" female XLR	\$11.99
WPE 129	38	1	Neutrik NC3FDL-1 Latching "D-Series" female XLR	\$11.99
WPE 130	38	1	Neutrik NC3FDL-1 Latching "D-Series" female XLR	\$11.99
WPE 131	38	1	Neutrik NC3FDL-1 Latching "D-Series" female XLR	\$11.99
WPE 132	38	1	Neutrik NC3FDL-1 Latching "D-Series" female XLR	\$11.99
WPE 135	42	1	Neutrik NL4MP "D-Series" 4 conductor Speakon	\$11.99
WPE 136	42	1	Neutrik NL4MP "D-Series" 4 conductor Speakon	\$11.99
WPE 137	42	1	Neutrik NL4MP "D-Series" 4 conductor Speakon	\$11.99
WPE 138	42	1	Neutrik NL4MP "D-Series" 4 conductor Speakon	\$11.99
WPE 139	42	1	Neutrik NL4MP "D-Series" 4 conductor Speakon	\$11.99
WPE 140	42	1	Neutrik NL4MP "D-Series" 4 conductor Speakon	\$11.99
WPE 141	42	1	Neutrik NL4MP "D-Series" 4 conductor Speakon	\$11.99
WPE 142	42	1	Neutrik NL4MP "D-Series" 4 conductor Speakon	\$11.99
WPE 143	42	1	Neutrik NL4MP "D-Series" 4 conductor Speakon	\$11.99
WPE 144	42	1	Neutrik NL4MP "D-Series" 4 conductor Speakon	\$11.99
WPE 145	42	1	Neutrik NL4MP "D-Series" 4 conductor Speakon	\$11.99
WPE 146	42	1	Neutrik NL4MP "D-Series" 4 conductor Speakon	\$11.99
WPE 147	42	2	Neutrik NL4MP "D-Series" 4 conductor Speakon	\$20.99
WPE 148	42	2	Neutrik NL4MP "D-Series" 4 conductor Speakon	\$20.99
WPE 149	42	2	Neutrik NL4MP "D-Series" 4 conductor Speakon	\$20.99
WPE 150	42	2	Neutrik NL4MP "D-Series" 4 conductor Speakon	\$20.99
WPE 151	42	2	Neutrik NL4MP "D-Series" 4 conductor Speakon	\$20.99
WPE 152	42	2	Neutrik NL4MP "D-Series" 4 conductor Speakon	\$20.99
WPE 153	40	1	Neutrik NC3MDL-1 "D-Series" male XLR	\$11.99
WPE 154	40	1	Neutrik NC3MDL-1 "D-Series" male XLR	\$11.99
WPE 155	40	1	Neutrik NC3MDL-1 "D-Series" male XLR	\$11.99
WPE 156	40	1	Neutrik NC3MDL-1 "D-Series" male XLR	\$11.99
WPU 1004	38	1	Single gang stainless steel wallplate, single Neutrik "D" punchout	\$3.44
WPU 1013	38	2	Single gang stainless steel wallplate, two Neutrik "D" punchout	\$4.96
WPU 2009	38	2	Dual gang stainless steel wallplate, one Neutrik "D" punchout per gang	\$8.46
WPU 2011	38	4	Dual gang stainless steel wallplate, two Neutrik "D" punchout per gang	\$11.52
WPU 3001	38	3	Triple gang stainless steel wallplate, one Neutrik "D" punchout per gang	\$13.12
WPU 3002	38	6	Triple gang stainless steel wallplate, two Neutrik "D" punchout per gang	\$17.72

NOTE: All Standard Engraved Wallplates are brushed 302 stainless steel. These wallplates are pre-assembled with rivets. All connectors are panel isolated.

Pricing and Specifications Subject to Change without Notice.

Plateworks™

Single-gang Wallplates - Loaded and Engraved

Model Number	Page No.	Connector Qty.	Connector Description	Suggested Resale
WPE 157	40	1	Neutrik NC3MDL-1 "D-Series" male XLR	\$11.49
WPE 158	40	1	Neutrik NC3MDL-1 "D-Series" male XLR	\$11.49
WPE 159	40	1	Neutrik NC3MDL-1 "D-Series" male XLR	\$11.49
WPE 160	40	1	Neutrik NC3MDL-1 "D-Series" male XLR	\$11.49
WPE 161	40	2	Neutrik NC3MDL-1 "D-Series" male XLR	\$20.49
WPE 162	40	2	Neutrik NC3MDL-1 "D-Series" male XLR	\$20.49
WPE 163	40	2	Neutrik NC3MDL-1 "D-Series" male XLR	\$20.49
WPE 164	40	2	Neutrik NC3MDL-1 "D-Series" male XLR	\$20.49
WPE 171	41	1	Neutrik NJ3FP6-C "D-Series" 1/4" locking phone jack	\$14.99
WPE 172	41	1	Neutrik NJ3FP6-C "D-Series" 1/4" locking phone jack	\$14.99
WPE 173	41	1	Neutrik NJ3FP6-C "D-Series" 1/4" locking phone jack	\$14.99
WPE 174	41	1	Neutrik NJ3FP6-C "D-Series" 1/4" locking phone jack	\$14.99
WPE 175	41	1	Neutrik NJ3FP6-C "D-Series" 1/4" locking phone jack	\$14.99
WPE 176	41	1	Neutrik NJ3FP6-C "D-Series" 1/4" locking phone jack	\$14.99
WPE 177	41	1	Neutrik NJ3FP6-C "D-Series" 1/4" locking phone jack	\$14.99
WPE 178	41	1	Neutrik NJ3FP6-C "D-Series" 1/4" locking phone jack	\$14.99
WPE 183	40	2	Neutrik NC3MDL-1 "D-Series" male XLR	\$20.49
WPE 184	40	2	Neutrik NC3MDL-1 "D-Series" male XLR	\$20.49

Dual-gang Wallplates - Loaded and Engraved

WPE 201	38	4	Neutrik NC3FDL-1 Latching "D-Series" female XLR	\$41.99
WPE 202	38	4	Neutrik NC3FDL-1 Latching "D-Series" female XLR	\$41.99
WPE 203	38	4	Neutrik NC3FDL-1 Latching "D-Series" female XLR	\$41.99
WPE 204	38	4	Neutrik NC3FDL-1 Latching "D-Series" female XLR	\$41.99
WPE 205	38	4	Neutrik NC3FDL-1 Latching "D-Series" female XLR	\$41.99
WPE 206	38	4	Neutrik NC3FDL-1 Latching "D-Series" female XLR	\$41.99

Triple-gang Wallplates - Loaded and Engraved

WPE 301	39	6	Neutrik NC3FDL-1 Latching "D-Series" female XLR	\$62.99
WPE 302	39	6	Neutrik NC3FDL-1 Latching "D-Series" female XLR	\$62.99
WPE 303	39	6	Neutrik NC3FDL-1 Latching "D-Series" female XLR	\$62.99
WPE 304	39	6	Neutrik NC3FDL-1 Latching "D-Series" female XLR	\$62.99

NOTE: All Standard Engraved Wallplates are brushed 302 stainless steel. These wallplates are pre-assembled with rivets. All connectors are panel isolated.

Blank/Punch-only Wallplates

Model Number	Page No.	Punch-Out Qty.	Plate Description	Suggested Resale
WP1000	38	0	Single Gang Blank Plate	\$3.49
WP2000	38	0	Dual Gang Blank Plate	\$6.49
WP3000	38	0	Triple Gang Blank Plate	\$9.49
WPU1004	38	1	Single Gang/Neutrik "D-Series" Punch Out	\$3.49
WPU1013	38	2	Single Gang/Neutrik "D-Series" Punch Out	\$4.99
WPU2009	38	2	Dual Gang/Neutrik "D-Series" Punch Out	\$8.40
WPU2011	38	4	Dual Gang/Neutrik "D-Series" Punch Out	\$11.99
WPU3001	38	3	Triple Gang/Neutrik "D-Series" Punch Out	\$13.49
WPU3002	38	6	Triple Gang/Neutrik "D-Series" Punch Out	\$17.99

NOTE: All Standard Blank and Punch-only Wallplates are brushed 430 stainless steel. No substitutions are possible.

Logo Panels

LP1	43	Custom laser engraved 1-space 19" rac panel	Suggested Resale \$99.98
-----	----	---------------------------------------------	------------------------------------

Lamacoid Markers

Model Number	Page No.	Labeling Description	Suggested Resale
8706-40-NUM	48	Numbers 1 - 40	\$67.49
8706-40-MIC	48	MIC 1 - MIC 40	\$67.49
8706-VAR A	48	Variety set A	\$67.49
870-VAR B	48	Variety set B	\$67.49

STANDARD LAMACOID MARKERS are black with white lettering, 1/16" thick, adhesive backed with beveled edges. Size available is 3/8" x 1".

For Lamacoid Markers not found in the LAMACOID MARKER VARIETY SETS, please refer to the PLATEWORKS LAMACOID MARKER COOKBOOK.

Pricing and Specifications Subject to Change without Notice.

Plateworks™ Standard Wallplates

Straight Plates

Pro Co Straight Plates allow sound contractors to use standard structural back boxes, with dual receptacle wallplates and floor pockets, as connection points for convenient audio hookup.

The Straight Plates accept Neutrik™ “D-style” connectors only, (several varieties of XLR males and XLR females, locking T/R/S 1/4” and 4-pole Speakons), rear mounted. A dimpled unloaded plate is offered for custom projects.

The oblong installation slot allows for straightening of the assembly when backboxes are installed crookedly.

Available in these standard unloaded and loaded configurations:

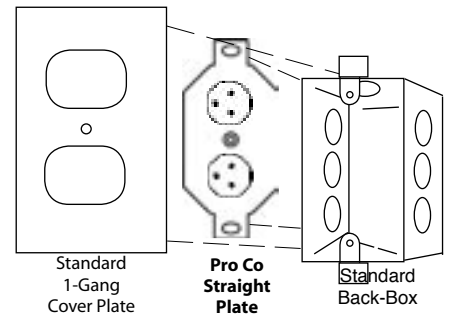
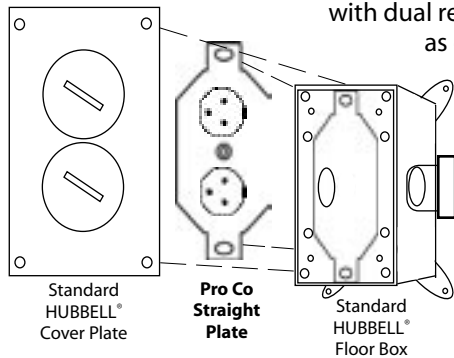

Model Number	Description	Suggested Resale	
STP-S*	(2) dimples for punch set-up, threaded hardware	\$11.49	
STP-B**	also available for center punch	\$11.49	
STP 1-S	(1) Neutrik™ “D-style” Punched hole	\$17.99	
STP 1-B		\$18.99	
STP 2-S	(2) Neutrik™ “D-style” Punched hole	\$18.99	
STP 2-B		\$19.99	
STP 3-S	(1) Neutrik™ “D-style” Punched hole, offset	\$17.99	
STP 3-B		\$18.99	
STP/3FX-1-S	Loaded: (1) centered NC3FDL-1-0, female XLR-type	\$21.99	
STP/3FX-1-B		\$22.49	
STP/3FX-2-S	Loaded: (2) NC3FDL-1-0, female XLR-type	\$28.49	
STP/3FX-2-B		\$29.49	
STP/SPK-1-S	Loaded: (1) NL4MP 4 pole Speakon speaker connector	\$25.99	
STP/SPK-1-B		\$26.99	
STP/SPK-2-S	Loaded: (2) NL4MP 4 pole Speakon speaker connectors	\$29.99	
STP/SPK-2-B		\$30.99	
STP/NJ3-1-S	Loaded: (1) centered NJ3FP6C, 3-Cond., 1/4” phone jack	\$26.99	
STP/NJ3-1-B		\$27.99	
STP/NJ3-2-S	Loaded: (2) NJ3FP6C, 3-Cond., 1/4” phone jacks	\$36.49	
STP/NJ3-2-B		\$38.99	
STP/NJ3-SPK-S	Loaded: (1) NJ3FP6C jack & (1) NL4MP 4-pole Speakon	\$28.49	
STP/NJ3-SPK-B		\$29.49	
STP/3FX-SPK-S	Loaded: (1) NL4MP 4-pole Speakon & (1) NC3FDL-1-0	\$28.49	
STP/3FX-SPK-B		\$29.49	
STP/NJ3-3FX-S	Loaded: (1) NJ3FP6C 3 cond. 1/4” jack & (1) NC3FDL-1-0	\$34.99	
STP/NJ3-3FX-B		\$35.99	

* -S = Stainless Steel Plate. ** -B = Galvanized Steel, Black Powder Coat.
As Stainless Steel quantities are reduced, only Black will be available.

Lamacoid Marker Variety Sets

Pro Co Lamacoid Markers are engraved plastic labels with an adhesive backing. They are suitable for use on wallplates, panels, floor pocket connector plates, stageboxes, and other similar applications where a professional identification label is needed.



Pro Co provides standard sets of lamacoid markers as shown below. In addition, individual markers can be ordered in a variety of sizes from our Lamacoid Cookbook. Lamacoid markers are cut using industrial lasers to provide the trade with absolutely clean, accurate and attractive markers per your personal requirements.

Variety Set Information: Sheet format, straight edges, snap-off construction. Each label measures 3/8" x 1".

Prices listed are suggested resale.

MIC 1	MIC 2	MIC 3	MIC 4	MIC 5
MIC 6	MIC 7	MIC 8	MIC 9	MIC 10
MIC 11	1	LINE	LINE	LINE
MIC 12	2	AUX	AUX	AUX
MIC 13	3	CUE	CUE	CUE
MIC 14	4	MON	MON	MON
MIC 15	5	OUTPUT	R	G
MIC 16	6	INPUT	B	SYNC

8706-40-VAR A

Set Includes MIC 1 thru MIC 16, Numbers 1 thru 6, R, G, B, Sync, Input, Output, (3) Line, (3) Cue, (3) Aux, (3) Mon

List \$67.49

MIC 36	MIC 37	MIC 38	MIC 39	MIC 40
MIC 31	MIC 32	MIC 33	MIC 34	MIC 35
MIC 26	MIC 27	MIC 28	MIC 29	MIC 30
MIC 21	MIC 22	MIC 23	MIC 24	MIC 25
MIC 16	MIC 17	MIC 18	MIC 19	MIC 20
MIC 11	MIC 12	MIC 13	MIC 14	MIC 15
MIC 6	MIC 7	MIC 8	MIC 9	MIC 10
MIC 1	MIC 2	MIC 3	MIC 4	MIC 5

8706-40-MIC

Set Includes MIC 1 thru MIC 40

List \$67.49

MIC 1	MIC 2	MIC 3	MIC 4	MIC 5
MIC 6	VIDEO	VIDEO	PHONO	PHONO
TAPE	1	LINE	LINE	LINE
TAPE	2	AUX	AUX	AUX
CD	3	CUE	CUE	CUE
CD	4	MON	MON	MON
AUDIO	5	OUTPUT	R	G
AUDIO	6	INPUT	B	SYNC

8706-40-VAR B

Set Includes MIC 1 thru MIC 6, Numbers 1 thru 6, R, G, B, Sync, Input, Output, (3) Line, (3) Cue, (3) Aux, (3) Mon, (2) CD, (2) Audio, (2) Video, (2) Phono

List \$67.49

36	37	38	39	40
31	32	33	34	35
26	27	28	29	30
21	22	23	24	25
16	17	18	19	20
11	12	13	14	15
6	7	8	9	10
1	2	3	4	5

8706-40-NUM

Set Includes Numbers 1 thru 40

List \$67.49

STANDARD LAMACOIDS MARKERS are black with white lettering, 1/16" thick, adhesive backed with beveled edges. Size available is 3/8"x1".

For Lamacoid Markers not found in the LAMACOIDS MARKER VARIETY SETS, please refer to the PLATEWORKS LAMACOIDS MARKER COOKBOOK.

Pro Co Floor Pockets

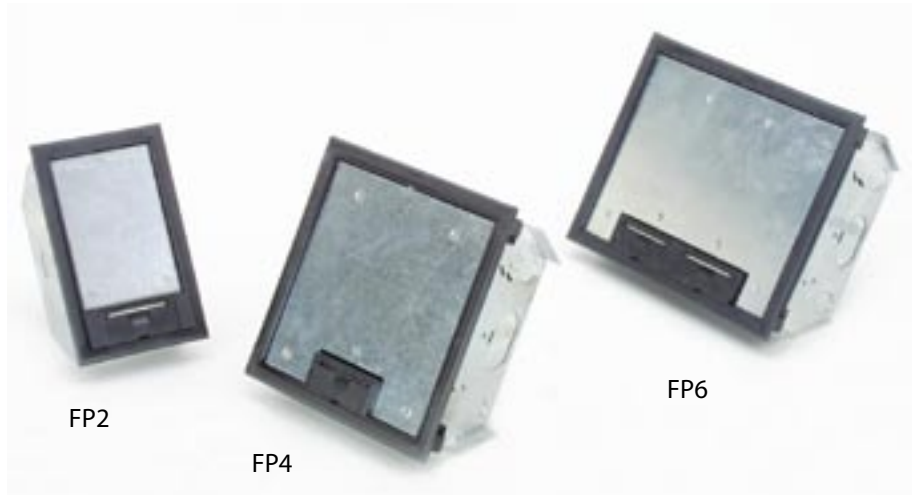

Floor Pockets

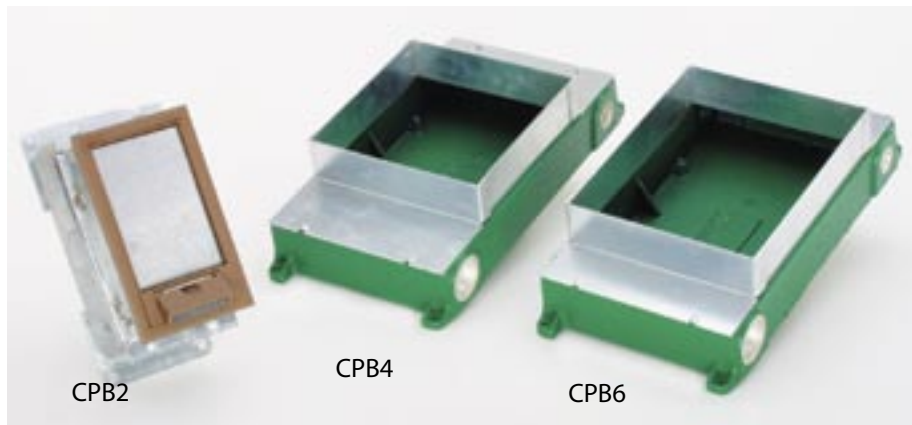

Concrete Pour Boxes

Plateworks™ Standard Floor Pockets

Floor Pockets

Model No.	Description	Suggested Resale
FP2-0	Floor pocket, small, black trim ring, accepts (2) FP2 Series Plates	\$173.45
FP2-1	Floor pocket, small, brown trim ring, accepts (2) FP2 Series Plates	\$173.45
FP2-8	Floor pocket, small, grey trim ring, accepts (2) FP2 Series Plates	\$173.45
FP4-0	Floor pocket, medium, black trim ring, accepts (2) FP4 Series Plates	\$265.16
FP4-1	Floor pocket, medium, brown trim ring, accepts (2) FP4 Series Plates	\$265.16
FP4-8	Floor pocket, medium, grey trim ring, accepts (2) FP4 Series Plates	\$265.16
FP6-0	Floor pocket, large, black trim ring, accepts (2) FP6 Series Plates	\$314.12
FP6-1	Floor pocket, large, brown trim ring, accepts (2) FP6 Series Plates	\$314.12
FP6-8	Floor pocket, large, grey trim ring, accepts (2) FP6 Series Plates	\$314.12

Concrete Pour Boxes

Model No.	Description	Suggested Resale
CPB2-0	Concrete pour box, black trim ring, accepts (2) FP2 Series Plates. Use is place of FP2 for Concrete floor applications.	\$272.07
CPB2-1	Concrete pour box, brown trim ring, accepts (2) FP2 Series Plates. Use is place of FP2 for Concrete floor applications.	\$272.07
CPB2-8	Concrete pour box, grey trim ring, accepts (2) FP2 Series Plates. Use is place of FP2 for Concrete floor applications.	\$272.07
CPB-4	Concrete pour box, accepts FP4 Series Floor Pocket.	\$287.04
CPB-6	Concrete pour box, accepts FP6 Series Floor Pocket.	\$319.49

Pro Co Floor Pockets

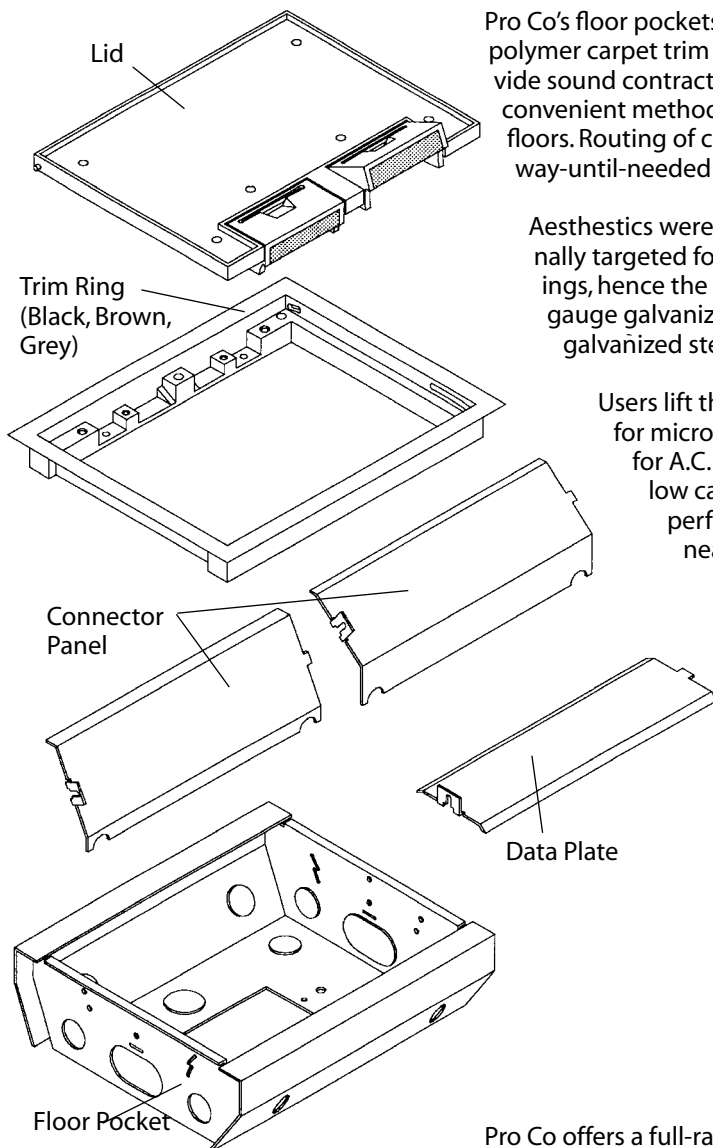

Pro Co's floor pockets are U.L. listed enclosures, provided with a steel top set into a polymer carpet trim ring. Designed with aesthetics in mind, these pockets provide sound contractors (using standard electrical conduit and hardware) with a convenient method of routing audio cabling through concrete and wood-joiced floors. Routing of cabling in this manner results in a neatly packaged, out-of-the-way-until-needed permanent installation.

Aesthetics were part of the original design. These floor pockets were originally targeted for A.C., telecom and computer signal routing in office buildings, hence the visual attractiveness. The floor pockets are built of 16 and 14 gauge galvanized steel, the concrete pour boxes of cast iron and 14 gauge galvanized steel.

Users lift the lid of the floor pockets for instant access to terminations for microphones, electronic instruments and speakers (inputs/outputs), for A.C. inputs, or for video terminations as required. Exit ports allow cables to be used with the lid closed for user safety. When the performance is over, the lid closes flush to the floor and becomes nearly invisible.

These features make our floor pockets usable in many installations:

- Ease of installation for the sound contractor (or the electrical contractor).
- U.L. Listing.
- Visual attractiveness and the ability to fit into a variety of surroundings (the carpet trim ring allows the use of any carpet or parkay flooring to be matched easily, literally "hiding" the floor pocket except for the exposed 1/2" trim ring.)
- Rugged assembly.
- Three sizes for different needs.
- Reasonable prices, especially when the connector options are considered.
- Customized termination panels to custom-fit your customer's special needs.

Pro Co offers a full-range of standard unpunched, punched and punched-and-loaded plates for audio terminations, plus complete custom-fabrication facilities are available for custom requirements.

There are more expensive floor pockets available for high-abuse situations (where fork-lifts are constantly running over them). There are less expensive floor pockets where function and cost override aesthetics and ease of use.

Pro Co's floor pockets offer the middle ground for a wide variety of applications — for visual appearance, for function, for value and reliability, at a reasonable price.

If your bids include churches, auditoriums and fine arts theatres, boardrooms or meeting rooms, both in new construction or renovation work, consider our floor pockets for your next installation.



NOTE: Pro Co stocks plates for Mystery, Ace, PSR, Walker, Hubbell and other floor pocket manufacturers' goods. We can punch and load connectors in them as well as laser engrave text and graphics on them. Call for details and quotes.

Pro Co Floor Pockets



Prices listed are suggested resale.

Standard Unloaded Connector Plates

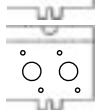

FP2 Series for FP-2

	AFP-2B-45 Blank 45°	\$14.14
	AC2-45 Dual Receptacle	\$11.72
	ND2-45 (2) Neutrik "D-series"	\$11.72

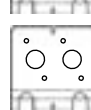
CP2 Series for CPB-2

	CPBP2-45 Blank	\$7.99
	CPAC2-45 Dual Receptacle	\$9.40
	CPND2-45 (2) Neutrik "D-series"	\$8.60

FP4 Series for FP-4

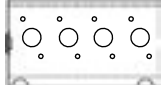
	AFP-4B-45 Blank 45°	\$14.25
	AFP-4B-60 Blank 60°	\$14.25
	AFD-4B Data*	\$22.24
	AC4-45 Dual Receptacle	\$11.04
	ND4-45 (4) Neutrik "D-series"	\$11.78
	ND4-60 (4) Neutrik "D-series"	\$11.78

FP6 Series for FP-6

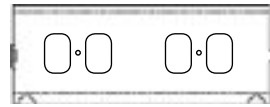
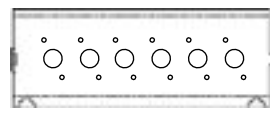
	AFP-6B-45 Blank 45°	\$15.74
	AFP-6B-60 Blank 60°	\$15.74
	AFD-6B Data*	\$33.98
	AC6-45 (2) Dual Receptacle	\$20.98
	ND6-45 (6) Neutrik "D-series"	\$20.98
	ND6-60 (6) Neutrik "D-series"	\$20.98

Connector Plate Wiring Channel

Used to hide unsightly cabling running between one connector plate and another connector plate.

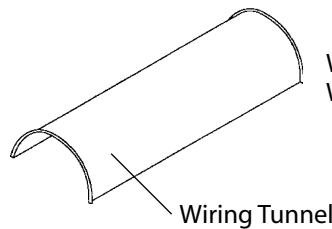

WT2 Used in FP-2 \$6.16
 WT4 Used in FP-4 and FP-6 \$14.22

*Must use 45° plates with this.

Pro Co Floor Pockets

Prices listed are suggested resale

FP2 Series for FP-2 Floor Pockets

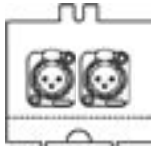

ND 2001
(2) Neutrik NC3FDL-1
"D-Series" 3 Cond.
Latching Female XLR
\$40.70

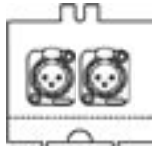

ND 2002
(2) Neutrik NC3MDL-1
"D-Series" 3 Cond.
Male XLR
\$38.24

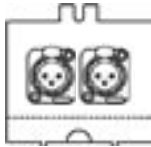

ND 2003
(1) Neutrik NC3FDL-1
Female XLR
(1) Neutrik NC3MDL-1
Male XLR
\$41.02

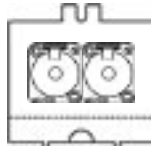

ND 2005
(2) Neutrik NJ3FP-6C
"D-Series" 3 Cond.
Locking 1/4" Jack
\$52.14

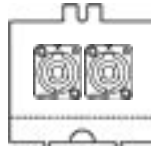

ND 2006
(2) Neutrik NL4MP
"D-Series" 4 Cond.
Speakon
\$41.46

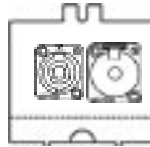

ND 2007
(1) Neutrik NC3FDL-1
Female XLR
(1) Neutrik NJ3FP-6C
3 Cond. 1/4" Jack
\$46.42

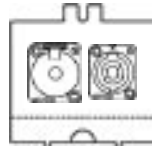

ND 2008
(1) Neutrik NJ3FP-6C
3 Cond. 1/4" Jack
(1) Neutrik NL4MP
4 Cond. Speakon
\$46.84

CP2 Series for CPB-2 Concrete Pour Boxes

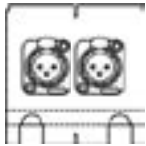

CND 2001
(2) Neutrik NC3FDL-1
"D-Series" 3 Cond.
Latching Female XLR
\$29.58

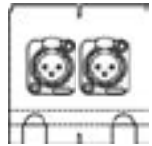

CND 2002
(2) Neutrik NC3MDL-1
"D-Series" 3 Cond.
Male XLR
\$30.28

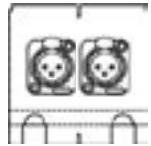

CND 2003
(1) Neutrik NC3FDL-1
Female XLR
(1) Neutrik NC3MDL-1
Male XLR
\$29.90

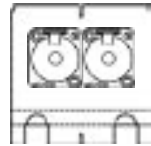

CND 2005
(2) Neutrik NJ3FP-6C
"D-Series" 3 Cond.
Locking 1/4" Jack
\$41.02

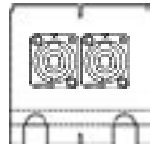

CND 2006
(2) Neutrik NL4MP
"D-Series" 4 Cond.
Speakon
\$30.44

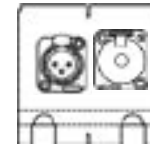

CND 2007
(1) Neutrik NC3FDL-1
Female XLR
(1) Neutrik NJ3FP-6C
3 Cond. 1/4" Jack
\$35.30

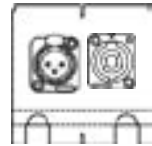

CND 2008
(1) Neutrik NJ3FP-6C
3 Cond. 1/4" Jack
(1) Neutrik NL4MP
4 Cond. Speakon
\$35.72

FP4 Series for FP-4 Floor Pockets

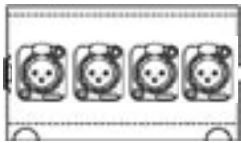

ND 4001
(4) Neutrik NC3FDL-1
"D-Series" 3 Cond.
Latching Female XLR
\$56.04

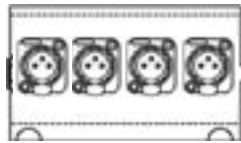

ND 4002
(4) Neutrik NC3MDL-1
"D-Series" 3 Cond.
Male XLR
\$57.28

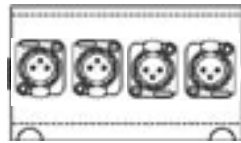

ND 4003
(2) Neutrik NC3FDL-1
Female XLR
(2) Neutrik NC3MDL-1
Male XLR
\$56.66

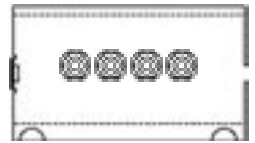

ND 4004
(4) Canare BCJ-JR
BNC Feedthru
\$102.44

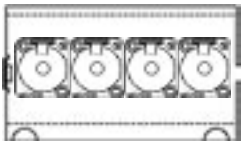

ND 4005
(4) Neutrik NJ3FP-6C
"D-Series" 3 Cond.
Locking 1/4" Jack
\$78.90

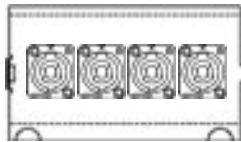

ND 4006
(4) Neutrik NL4MP
"D-Series" 4 Cond.
Speakon
\$57.74

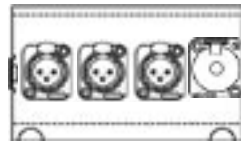

ND 4007
(3) Neutrik NC3FDL-1
Female XLR
(1) Neutrik NJ3FP-6C
3 Cond. 1/4" JACK
\$61.76

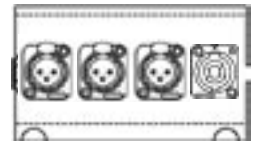

ND 4008
(3) Neutrik NJ3FP-6C
3 Cond. 1/4" Jack
(1) Neutrik NL4MP
4 Cond. Speakon
\$56.46

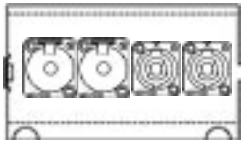

ND 4009
(4) Neutrik NJ3FP-6C
"D-Series" 3 Cond.
Locking 1/4" Jack
\$68.32

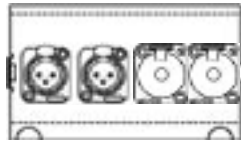

ND 4010
(2) Neutrik NJ3FP-6C
3 Cond. 1/4" Jack
(2) Neutrik NL4MP
4 Cond. Speakon
\$67.48

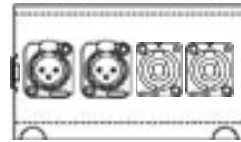

ND 4011
(2) Neutrik NC3FDL-1
Female XLR
(2) Neutrik NL4MP
4 Cond. Speakon
\$56.90

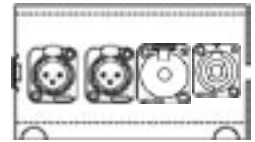

ND 4012
(2) Neutrik NC3FDL-1 Female XLR
(1) Neutrik NJ3FP-6C 3 Cond. 1/4" Jack
(1) Neutrik NL4MP 4 Cond. Speakon
\$62.68

Pro Co Floor Pockets

Prices listed are suggested resale

FP6 Series for FP-6 Floor Pockets

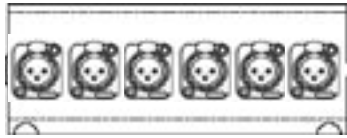

ND 6001
(6) Neutrik NC3FDL-1 "D-Series"
3 Cond. Latching Female XLR
\$83.36

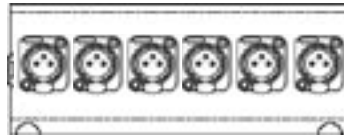

ND 6002
(6) Neutrik NC3MDL-1 "D-Series"
3 Cond. Male XLR
\$89.08

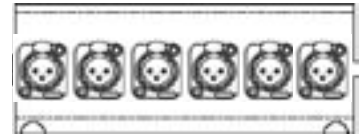

ND 6007
(5) Neutrik NC3FDL-1 "D-Series"
3 Cond. Latching Female XLR
(1) Neutrik NJ3FP-6C "D-Series"
3 Cond. Locking 1/4" Jack
\$89.90

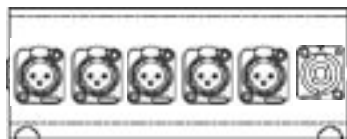

ND 6008
(5) Neutrik NC3FDL-1 "D-Series"
3 Cond. Latching Female XLR
(1) Neutrik NL4MP "D-Series"
4 Cond. Speakon
\$83.78

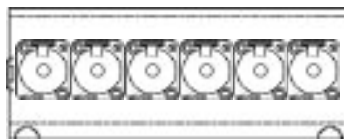

ND 6009
(6) Neutrik NJ3FP-6C "D-Series"
3 Cond. Locking 1/4" Jack
\$111.66



ND 6010
(6) Neutrik NL4MP "D-Series"
4 Cond. Speakon
\$85.90



ND 6012
(4) Neutrik NC3FDL-1 "D-Series"
3 Cond. Latching Female XLR
(2) Neutrik NJ3FP-6C "D-Series"
3 Cond. Locking 1/4" Jack
\$94.80

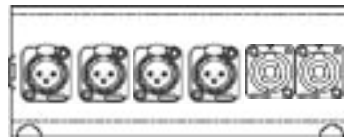

ND 6013
(4) Neutrik NC3FDL-1 "D-Series"
3 Cond. Latching Female XLR
(2) Neutrik NL4MP "D-Series"
4 Cond. Speakon
\$84.22

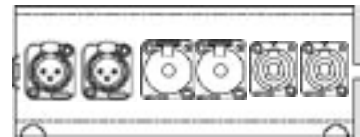

ND 6015
(2) Neutrik NC3FDL-1 "D-Series"
3 Cond. Latching Female XLR
(2) Neutrik NJ3FP-6C "D-Series"
3 Cond. Locking 1/4" Jack
(2) Neutrik NL4MP "D-Series"
4 Cond. Speakon
\$95.64

Essentials Bulk Audio Cables

Single-Conductor Shielded Audio Cable

Description: Single-conductor shielded audio cable (2120SM is a parallel cable with two individually shielded conductors.)

Applications: High-Impedance Microphones, Musical Instruments, Unbalanced Equipment Hookup and Patching

Model Number	Number of Conductors	Conductor Gauge (AWG)	Number of Strands	Strand Gauge (AWG)	Conductor Material	Insulation Thickness (in.)	Insulation Material	Type of Shield	Shield Material	Shield Coverage (%)
120SX	1	20	41	36	BC	0.033	PE	Serve (n.1)	BC	90
120S1	1	20	41	36	BC	0.033	PE	Serve (n.1)	BC	55
120SM	1	20	26	34	BC	0.023	PE	Serve (n.2)	BC	50
2120SM	2	20	26	34	BC	0.023	PE	Serve (n.2)	BC	72

Two-Conductor Shielded Audio Cable

Description: Two-conductor shielded audio cable. Applications: Low-Impedance Microphones, Low Impedance Line Level and Unbalanced Line/Instrument Connection

223B	2	23	19	36	BC	0.020	PE	Braid	BC	94
224S	2	24	16	36	BC	0.018	PVC	Serve	BC	90
224SM	2	24	16	36	BC	0.012	PE	Serve	BC	80

Four-Conductor Shielded Audio Cable

Description: Four-conductor shielded audio cable. Kevlar strength member. Applications: Low-Impedance Microphones, Low Impedance Line Level and Unbalanced Line/Instrument Connection

424BK	4	24	42	40	BC	0.015	PE	Braid	TC	96
-------	---	----	----	----	----	-------	----	-------	----	----

Unshielded Audio Cable

Description: Unshielded audio cable, Twisted pair, Round overall jacket, Highly stranded, Very flexible. Applications: Loudspeaker interconnection

12-2	2	12	65	30	BC	0.023	PVC	None	None	None
14-2	2	14	41	30	BC	0.022	PVC	None	None	None
16-2	2	16	65	34	BC	0.016	PVC	None	None	None

Description: Unshielded audio cable, Twisted pair, Parallel (ZIP Cable) construction, 10-2 & 12-2 is Highly stranded & Very flexible. For Loudspeaker interconnection

10-2 Z	2	10	420	36	BC	0.050	PVC (clear)	None	None	None
--------	---	----	-----	----	----	-------	-------------	------	------	------

Description: Multipair speaker cable, Twisted pairs, Round overall jacket.

11-4	4	11	82	30	BC	0.030	TPE	None	None	None
13-8	8	13	52	30	BC	0.030	TPE	None	None	None

Four-Conductor Shielded Data Cable

Description: Four-conductor shielded data cable. Applications: MIDI/Sync interconnection

424F	4	24	7	32	TC	0.010	PP	Foil (n.3)	Alum/Poly	100
------	---	----	---	----	----	-------	----	------------	-----------	-----

CL2 Rated Multi-Conductor Shielded Studio Hookup Cable

Description: Multi-pair 100% shielded audio cable for studio hookup.

ACC1	1	24	7	32	BC	0.012	PP	Foil (n.3)	Alum/Poly	100%
ACC2	2	24	7	32	BC	0.012	PP	Foil (n.3)	Alum/Poly	100%
ACC4	4	24	7	32	BC	0.012	PP	Foil (n.3)	Alum/Poly	100%
ACC8	8	24	7	32	BC	0.012	PP	Foil (n.3)	Alum/Poly	100%
ACC16	16	24	7	32	BC	0.012	PP	Foil (n.3)	Alum/Poly	100%
ACC26	26	24	7	32	BC	0.012	PP	Foil (n.3)	Alum/Poly	100%

Non-CL2 Rated Multi-Conductor Shielded Studio Hookup Cable

Description: Multi-pair 100% shielded audio cable for studio hookup.

ACN8	8	24	7	32	BC	1.012	PP	Foil (n.3)	Alum/Poly	100%
ACND8	8	24	7	32	BC	0.012	PP	Foil (n.3)	Alum/Poly	100%

Multi-Conductor Portable Audio Snake Cable

Description: Flexible 100% shielded audio cable for grueling professional touring use.

DLA8	8	24	7	32	BC	0.012	PP	Foil (n.3)	Alum/Poly	100%
DLA12	12	24	7	32	BC	0.012	PP	Foil (n.3)	Alum/Poly	100%
DLA16	16	24	7	32	BC	0.012	PP	Foil (n.3)	Alum/Poly	100%
DLA20	20	24	7	32	BC	0.012	PP	Foil (n.3)	Alum/Poly	100%
DLA28	28	24	7	32	BC	0.012	PP	Foil (n.3)	Alum/Poly	100%
DLA32	32	24	7	32	BC	0.012	PP	Foil (n.3)	Alum/Poly	100%

CL2 Rated Multi-Conductor Portable/Permanent Snake Cable

Description: CL2 fire-rated cable for permanent installation use.

DLAC8	8	24	7	32	BC	0.012	PP	Foil (n.3)	Alum/Poly	100%
DLAC12	12	24	7	32	BC	0.012	PP	Foil (n.3)	Alum/Poly	100%
DLAC16	16	24	7	32	BC	0.012	PP	Foil (n.3)	Alum/Poly	100%
DLAC20	20	24	7	32	BC	0.012	PP	Foil (n.3)	Alum/Poly	100%
DLAC28	28	24	7	32	BC	0.012	PP	Foil (n.3)	Alum/Poly	100%
DLAC32	32	24	7	32	BC	0.012	PP	Foil (n.3)	Alum/Poly	100%
DLAC40	40	24	7	32	BC	0.012	PP	Foil (n.3)	Alum/Poly	100%
DLAC48	48	24	7	32	BC	0.012	PP	Foil (n.3)	Alum/Poly	100%
DLAC56	56	24	7	32	BC	0.012	PP	Foil (n.3)	Alum/Poly	100%
DLAC67	67	24	7	32	BC	0.012	PP	Foil (n.3)	Alum/Poly	100%

Notes:

1. Also has 100% coverage conductive PVC shield.
2. Also has 100% coverage textile tape wrap shield.
3. Also has 24 AWG (7/32) 1C drain wire.
4. Between paired conductors.
5. Between one conductor and remaining conductor(s) tied to shield.

Key to Abbreviations:

BC	bare copper	TPE	thermoplastic elastomer
TC	tinned copper	PP	polypropylene
PE	polyethylene	AWG	American Wire Gauge
PVC	polyvinyl chloride	Alum/Poly	aluminum/polyester

Jacket Thickness (in.)	Jacket Material	Outside Diameter (in.)	Outside Diameter (mm.)	Capacitance (pF/ft.) (Note 4)	Capacitance (pF/m.) (Note 4)	Capacitance (pF/ft.) (Note 5)	Capacitance (pF/m.) (Note 5)	Suggested Retail Price Per Foot	Fire Rating
0.067	PVC	0.280	7.0	n/a	n/a	41	134	.33	—
0.046	PVC	0.240	6.1	n/a	n/a	41	134	.28	—
0.035	PVC	0.194	4.9	n/a	n/a	45	164	.45	—
0.035	PVC	.200 x .402	5.1 x 10.2	n/a	n/a	45	148	.66	—
0.034	PVC	0.240	6.1	19	62	36	118	.62	—
0.047	PVC	0.235	6.0	45	148	76	249	.37	—
0.040	PVC	0.195	5.0	22	72	38	124	.33	—
0.040	PVC	0.240	6.1	39	128	64	210	.91	—
0.030	PVC	0.375	9.5	56	184	n/a	n/a	.33	—
0.030	PVC	0.325	8.3	67	220	n/a	n/a	.45	—
0.030	PVC	0.260	6.6	50	164	n/a	n/a	2.09	—
n/a	n/a	.245 x .480	6.2 x 12.26	60	196	n/a	n/a	.66	—
0.060	PVC	0.570	14.5	17	56	26	85	2.05	—
0.050	PVC	0.590	15.0	18	59	30	98	1.21	—
0.045	PVC	0.211	5.4	22	72	35	115	.37	—
0.075	PVC	0.134	0.440	22	72	35	115	.19	CL2
0.075	PVC	.205 X .335	.673 X 1099	22	72	35	115	.56	CL2
0.075	PVC	0.370	1.214	22	72	35	115	1.06	CL2
0.075	PVC	0.475	1.558	22	72	35	115	2.09	CL2
0.075	PVC	0.738	2.421	22	72	35	115	3.01	CL2
0.075	PVC	0.865	2.838	22	72	35	115	4.37	CL2
1.075	PVC	1.475	4.839	22	72	35	115	1.45	—
0.150	PVC	0.520	1.706	13.5	44.3	25.5	83.7	1.90	110 Ω
0.050	PVC	0.415	1.362	22	72	35	115	1.40	—
0.050	PVC	0.500	1.640	22	72	35	115	1.78	—
0.050	PVC	0.570	1.870	22	72	35	115	2.33	—
0.050	PVC	0.630	2.067	22	72	35	115	2.48	—
0.050	PVC	0.730	2.395	22	72	35	115	3.76	—
0.050	PVC	0.800	2.625	22	72	35	115	4.62	—
0.050	PVC	0.415	1.362	22	72	35	115	1.50	CL2
0.050	PVC	0.500	1.640	22	72	35	115	1.92	CL2
0.050	PVC	0.570	1.870	22	72	35	115	2.50	CL2
0.050	PVC	0.630	2.067	22	72	35	115	2.67	CL2
0.050	PVC	0.730	2.395	22	72	35	115	4.05	CL2
0.050	PVC	0.800	2.625	22	72	35	115	4.96	CL2
0.050	PVC	0.860	2.821	22	72	35	115	7.13	CL2
0.050	PVC	0.880	2.887	22	72	35	115	7.97	CL2
0.050	PVC	0.950	3.117	22	72	35	115	9.45	CL2
0.050	PVC	1.020	3.346	22	72	35	115	11.29	CL2

Essentials

Retail Display Connectors and Wire

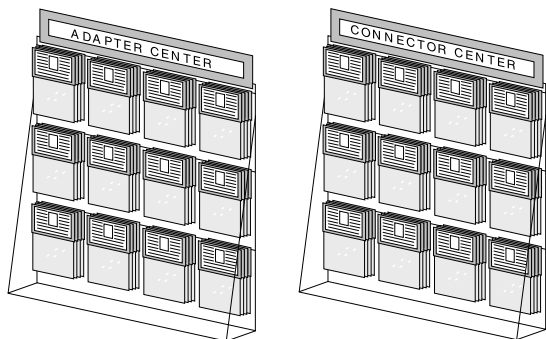

AC-L Adaptor Center Display

Model Number	Description	Suggested Resale
CC-L	Connector Center Display	\$303.04
AC-L	Adaptor Center Display	\$164.49

Packaged connectors for replacement of inventory for above displays.

CC-330F1PC	2-RCA jacks to 1-RCA plug	\$3.99
CC-330PJPC	2-RCA jacks to 1-1/4" phone plug	\$3.99
CC-336APC	Phone jack to RCA plug	\$3.49
CC-340PC	2-1/4" phone jacks to 1-1/4" phone plug	\$5.49
CC-341PC	2-stereo mini to 1-1/4" stereo phone plug	\$6.99
CC-342PC	1/4" stereo phone jack to stereo mini plug	\$2.99
CC-343PC	Stereo mini jack to 1/4" stereo phone plug	\$2.99
CC-344PC	2-stereo 1/4" phone jacks to 1-1/4" stereo plug	\$4.99
CC-345APC	RCA jack to 1/4" phone plug	\$2.49
CC-361APC	1/4" phone jack to 1/4" phone jack	\$4.49
CC-363PC	1/4" phone plug to 1/4" phone plug	\$4.49

CC-L Connector Center Display

Model Number	Description	Suggested Resale
CC-11 (2-pak)	2 conductor 1/4" phone jack	\$3.99
CC-151 PC	1/4" thick panel phone jack	\$7.99
CC-3502HD (2-pak)	RCA phone plug	\$3.49
CC-BF2P	2 conductor 1/4" phone plug	\$2.99
CC-BF3P	3 conductor 1/4" phone plug	\$4.99
CC-MDP (2-pak)	Dual banana jack 2 pack	\$4.99
CC-MF2P	2 conductor 1/4" phone plug large barrel	\$5.99
CC-NC3FDL-1	XLR 3 pin female receptacle	\$4.49
CC-NC3FX	XLR 3 pin male receptacle	\$4.49
CC-NC3MX	XLR 3 pin male receptacle	\$4.49
CC-RF2P	2 conductor 1/4" right angle phone plug	\$5.49
CC-RP S/W(9)	Rack panel screws and washers	\$2.49
CC-ACC-3-8	AC line cable 3 conductor	\$10.99

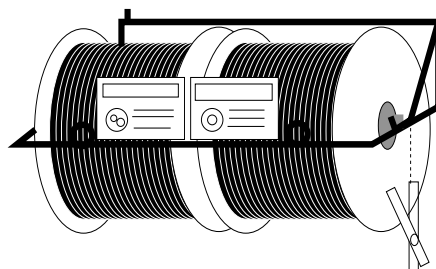









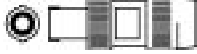
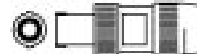
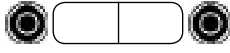

WC-L Wire Center Display



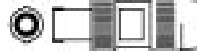

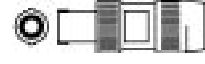





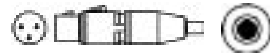

Model Number	Description	Suggested Resale per Spool
WC-AC1	Spool 500 ft . AC1	\$111.99
WC-224S	Spool 500 ft. 224S	\$198.49
WC-223B	Spool 500 ft. 223B	\$322.49
WC-120SX	Spool 350 ft. 120SX	\$176.49
WC120S1	Spool 500 ft. 120S1	\$180.49
WC120SM	Spool 500 ft. 120SM	\$162.99
WC2120SM	Spool 250 ft. 2120SM	\$186.49
WC10-2Z	Spool 250 ft. 10-2Z	\$508.86
WC-12-2	Spool 250 ft. 12-2	\$171.99
WC-14-2	Spool 350 ft. 14-2	\$177.99
WC-16-2	Spool 500 ft. 16-2	\$175.49
WC-Rack	Rack for two spools Includes wire stripper and Sign Cards	N/C

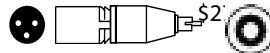
Bulk Parts

Neutrik Speakon Speaker Connectors

NEUTRIK Speakon Speaker Connectors		Model Number	Description	Sug. Resale
	NL2FC	Female, cable mount, 2-pin loudspeaker connector	\$4.66	
	NL4FC	Female, cable mount, 4-pin loudspeaker connector	\$8.08	
	NL4FX NL4FRX	New 4-pole Speakon New right angle 4-pole Speakon	\$6.45 \$8.64	
	NL4MM	Coupler, male to male speakon, 4-pin	\$8.40	
	NL4MMX LRX	New 4-pole Coupler Right angle kit for new Speakon	\$8.67 \$2.49	
	NL2MP	Male, panel mount, 2-pin speakon	\$3.38	
	NL4MP	Male, panel mount, 4-pin speakon	\$4.05	
	NL4MP-ST	4-pole Speakon panel mount screw terminal, 60 ga. wire	\$4.65	
	NL4MPR	Male, panel mount, 4-pin speakon, EP retrofit	\$4.63	
	NL8FC	Female, cable mount, 8-pin loudspeaker connector	\$16.56	
	NL8MM	Coupler, male to male speakon, 8-pin	\$29.01	
	NL8MPR	Male, panel mount, 8-pin speakon, EP retrofit	\$11.76	
	NA4LJ	Adapter, Female 4-pin Speakon to 1/4" phone plug. Wired circuit "1."	\$11.41	



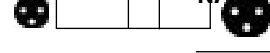



NEUTRIK GNS Modular Gooseneck Systems	
	No noise, stainless steel, non-reflective matte black finish, modular gooseneck sets including: gooseneck (7", 14", or 20"), female XLR module with locking ring for securing microphones, 2 male thread adapters (M 17 x 1" - 3/8") and thread adapter (MX 17 x 1-5/8") female with cable outlet, through-hole and mounting facility to panels up to 7mm. Mates with ATLAS AD-1
(System) GNS-18	\$58.74
(System) GNS-36	\$71.34
(System) GNS-50	\$78.94
(Gooseneck Only) GN-18	\$19.80
(Gooseneck Only) GN-36	\$26.88
(Gooseneck Only) GN-50	\$49.92

"NA" Series Adapters		Model Number	Description	Sug. Resale
	NA2FBNC	XLR Female to BNC Female	\$17.24	
		Unwired Locking Latch: Yes		
	NA2FFP	XLR Female to 1/4" Phone	\$11.80	
		Unwired Locking Latch: Yes		
	NA2FPMF	XLR Female to RCA Jack	\$10.85	
		Unwired Locking Latch: Yes		
	NA2FPMM	XLR Female to RCA Plug	\$27.76	
		Unwired Locking Latch: Yes		
	NA2MPMM	XLR Male to RCA Plug	\$27.76	
		Unwired Locking Latch: No		
	NA2MFFP	XLR Male to BNC Female	\$15.78	
		Unwired Locking Latch: No		
	NA2MPMF	XLR Male to RCA Jack	\$27.59	
		Unwired Locking Latch: No		
	NA2FFW	XLR Female to XLR Female	\$15.56	
		Wired Locking Latch: Yes		
	NA2FF3	XLR Female to 3-con. Phone Jack	\$13.52	
		Unwired Locking Latch: Yes		
	NA2FFX	XLR Female to XLR Male	\$12.66	
		Unwired Locking Latch: Yes		
	NA2FF3P	XLR Female to 3-Cond. Phone Plug	\$12.60	
		Unwired Locking Latch: Yes		
	NA2MFF3	XLR Male to Locking 1/4" Phone Jack	\$12.88	
		Unwired Locking Latch: Yes		
	NA2MFFW	XLR Male to XLR Male	\$14.26	
		Wired Locking Latch: No		
	NA2MFF3P	XLR Male to 3-Cond. Phone Plug	\$12.21	
		Unwired		

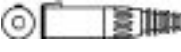

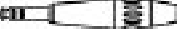

****Only the NA3FF/W and NA3MM/W are pre-wired for immediate shipment; the others may be wired on request.**

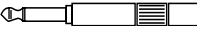

Bulk Parts

Neutrik 1/4" Connectors

"NJ" and "NP" 1/4" Phone Jacks and Plugs		Model Number	# of Pins Shell	Contacts	Locking Latch	Special Features	Sug. Resale	
	NJ3FC6		3	N	S	Y	1/4" Inline Jack	\$9.84
	NJ3FC6-BAG		3	BC	S	Y	1/4" Inline Jack	\$9.45
	NJ3FP6C		3	N	S	Y	1/4" Jack	\$7.12
	NJ3FP6C-BAG		3	BC	S		1/4" Jack	\$8.98
	NP2C		2	N	N	N		\$5.04
	NP2C-BAG		2	BC	N	N		\$5.04
	NP2C-T10AA		2	N	N	N	TFMR	\$30.96
	NP2RC		2	N	N	N	RA	\$8.56
	NP3C		3	N	N	N		\$5.84
	NP3C-BAG		3	BC	N	N		\$5.99
	NP3RC		3	N	N	N	RA	\$10.16
	NP3RC-BAG		3	BC	N	N	RA	\$10.86





Neutrik Long Frame 1/4" Plugs (Military grade)		Model Number	# of Pins Shell	Contacts	Locking Latch	Sug. Resale	
	NP3TB-B		3	BC	N	N	\$10.04
	NP3TB-R		3	Red	N	N	\$10.04



Neutrik Powercons		Model Number	# of Contacts	Shell	Contacts	Locking Latch	Special Features	Sug. Resale
20 amp "Quick-lock," 3-pole, ULR recognized, AC Connectors								
	NAC3FCA						Cable, Power In, Blue	\$9.81
	NAC3FCB						Cable, Power Out, Gray	\$9.81
	NAC3MPA						Panel, Power In, Blue	\$5.04
	NAC3MPB						Panel, Power Out, Gray	\$5.04
	NAC3MM						Coupler for linking cables	\$19.86

5-Pin Din "MIDI" Connectors		Model Number	# of Contacts	Shell	Contacts	Locking Latch	Special Features	Sug. Resale
	NYS322		5	N	S	N		\$1.81
	71432-151		5	N	S	N	RA	\$10.40
	NYS325		5	N	S	N		\$1.08
	MA-1						Coupler, 5-pin MIDI to 5-Pin MIDI	\$2.32

Re'an Patch Panels		Model Number	Description	Sug. Resale
				
Long Frame Military Grade, 48 pt., single space, Patch Panel				
LF48-1A		Red front		\$630.40
LF48-1D		Blue front		\$630.40
LF48-1O		Black front		\$630.40
LF48-1S		Silver front		\$630.40

Neutrik Patch Bay		Model Number	Description	Sug. Resale
				
NYS-SPP-L		Economy 48 pt. modular patch bay in one rack space		\$151.02





Pro Co Switches		Model Number	Description	Sug. Resale
	7707001		3PDT footswitch, push on/push off. 6A 125 VAC	\$9.95
	110-63		On/off switch, SPST, toggle, 6A 125 VVAC	\$6.27
	7101-MYZQE		SPDT short-bat mini-toggle, 5A 125 VAC	\$11.97
	7201-MYZQE		Same As Above, DPDT	\$12.11
	621-11221		Carling, SPDT rocker switch	\$3.51
	621-12221		Carling, DPDT rocker switch	\$2.99

Ethercon		Model Number	Description	Sug. Resale
New ruggedized "D" and "A" style Neutrik panel connectors and XLR sized cable housings designed to protect the fragile latch and cover of standard JR45 connectors from breakage.				
	NE8FDV-YK		Ethercon Krone panel, IDC punch down	\$14.49
	N38FDV-Y110		Ethercon 100 ohm panel, IDC punch down	\$14.49
	NE8MC		Ethercon cable housing, nickel RJ45's not included	\$4.49
	NE8MC-B		Ethercon cable housing, black RJ45's not included	\$4.49



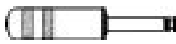
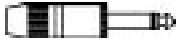



Bulk Parts

G&H Industries Audio Connectors

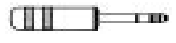
1/4" Big Foot 2-Cond. (T/S) Phone Plugs

Model Number	Diameter for Cable Entry	Finish	No. of Conductors	Barrel Finish Options	Plug Options	Sug. Resale
 BF2P	.300"	N	2	G Bl Br	G QP	\$2.99
 BF2PS	.400"	N	2	G Bl Br	G QP	\$4.03
 MF2P	.500"	N	2	G Bl Br	G QP	\$5.46
 RMF2P	.500"	N	2	G Bl Br	G QP	\$12.85
 RF2P	.300"	N	2	G Bl Br	G QP	\$4.92
 RF2PS	.400"	N	2	G Bl Br	G QP	\$12.06

1/4" Big Foot 3-Cond. (T/R/S) Phone Plugs

 BF3P	.300"	N	3	G Bl Br	G	\$4.38
 BF3PS	.400"	N	3	G Bl Br	G	\$4.42
 MF3P	.500"	N	3	G Bl Br	G	\$4.99
 RMF3P	.500"	N	3	G Bl Br	G	\$19.76
 RF3P	.300"	N	3	G Bl Br	G	\$6.25
 RF3PS	.400"	N	3	G Bl Br	G	\$17.60

New

Field Pack	BF2PFP6	Field Pack (6)	\$17.98
	BF3PFP6	Field Pack (6)	\$28.98
Bulk Pack	BF3PBP50	Bulk Pack (50)	\$114.00
	BF3FBP50	Bulk Pack (50)	\$204.00

G&H The Boss™ Banana Plugs

Model Number	Body Color	Contact Finish Option	Sug. Resale
 BBN Black	Black	G	\$4.13
BBN Red	Red	G	\$4.13
BBN Brown	Brown	G	\$4.13
BBN Yellow	Yellow	G	\$4.13
BBN Orange	Orange	G	\$4.13
BBN Blue	Blue	G	\$4.13
BBN Green	Green	G	\$4.13

G&H Tiny Telephone (Bantam) Plugs

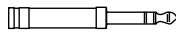
Model Number	Shell Finish	Tip Finish	Sug. Resale
 TT3P-B	Black	Nickel	\$8.38
TT3P-N	Nickel	Nickel	\$8.38
TT3P-R	Red	Nickel	\$8.38

Thomas Betts

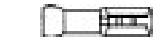



Disconnects	Model Number	Wire Range	Max. Ins.	Bolt Hole	Sug. Resale
	FD187-14(25)		14	.250	NA
	\$5.32				
	FD187-10(25)		12	.250	NA

BF3P T/R/S 1/4" Phone Plugs









- Easy to Strip; Easy to Solder; Easy to Assemble
 - Only one strip length is needed
 - Wire is easy to position in solder cups
 - Ground can be crimped, soldered or both
 - Extra set of "ears" for cable strain relief
- Built to last longer than the service life of the equipment it hooks up
- Least costly quality connector on the market



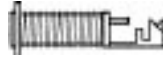





Amphenol Audio XLR Connectors



Model Number	Description	Sug. Resale
 AC3M	3-pin Male solder type, cable mount XLR	\$4.77
AC3MI	3-pin Male solderless IDC type, cable mount XLR	\$2.37
 AC3F	3-pin Female solder type, cable mount XLR	\$5.50
AC3FI	3-pin Female solderless IDC type, cable mount XLR	\$3.75
 AC3MDZ	3-pin Male solder type, "D" series, metal panel mount XLR	\$4.13
AC3MDPI	3-pin Male solderless IDC type, "D" series, plastic shell, panel mount XLR	\$2.05
 AC3FDZ	3-pin Female solder type, "D" series, metal panel mount XLR	\$5.31
AC3FDPIL	3-pin Female solderless IDC type, "D" series, plastic shell, panel mount XLR	\$2.47







Bulk Parts

Pro Co Connectors







Pro Co "PC" Series Connectors	Model Number	# of Pins	Shell	Contacts	Locking Latch	Special Features	Sug. Resale
	121HD	2	N	N	N		\$3.22
	151PC	2	N	N	N		\$7.19
	780PC	2	N	N	N	ø3.5mm	\$1.73
	797PC	3	N	N	N	ø3.5mm	\$2.57
	3501FRPC	2	N	N	N	ø3.5mm	\$2.85
	3502PC	2	N	N	N	RCA	\$1.52
	3502HD	2	N	N	N	HD, RCA	\$1.99
	3503PC	2	N	N	N	FRCA	\$2.15





Switchcraft Parts Non-Cross-Referenced Parts	Model Number	# of Conductors	Shell	Contacts	Locking Latch	Type	Sug. Resale
	TA3FL	3	P	S	Y	TINI-QG	\$11.06
	TA3ML	3	P	S	N	TINI-QG	\$15.50
	35HDNN	3	N	N	N	LD	\$8.28
	L11	2	N	N	N	1/4" Longframe	\$3.00
	L12B	3	N	N	N	1/4" Longframe	\$4.12
	NL112B	3	P	N	N	1/4"	\$4.24
	L114B	3	P	N	N	1/4"	\$4.92
	131	3	N	N	N	1/4" (T/R/S)	\$14.96







Miscellaneous Jacks	Model Number	# of Pins	Shell	Contacts	Locking Latch	Special Features	Sug. Resale
	27-655	3	P	S	N	ø3.5mm	\$1.17
	LS112B	3	P	S	N	1/4"	\$0.99
	LS142A	2	P	S	N	ø3.5mm	\$0.99



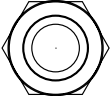

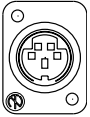

Canare, Neutrik & Amphenol Video Connectors	Model Number	Description	Sug. Resale
	Neutrik NBB75DFI	"D" style Panel Mount	\$11.13
	Amphenol AL-BNC-JJ-75	Feedthru BNC Connector	\$9.15
	Canare BCJ-JRU	Recessed 75Ω	\$14.80
	Neutrik NBB75FI	Feedthru BNC	\$12.12
	Amphenol AL-BNC-JJA-75	Panel Mount Jack	\$8.09
	Canare BCJ-JR	Bulkhead 75Ω	\$11.53
	Blonder-Tongue GF8IC	"F" or "G" type feedthru connector	\$4.18

Pro Co Transformers

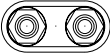
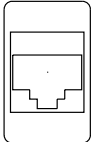
Pro Co Transformers	Model Number	Description	Sug. Resale
	DBT-1	Pro Co direct box transformer. 20kΩ/150Ω, dual electrostatic shields, open channel frame construction with mounting ears. 4" color coded leads.	\$42.90
	MBT-1	Pro Co microphone bridging transformer. 150Ω/150Ω, dual electrostatic shields, MU-metal shielding, open channel frame construction with mounting ears. 10" color coded leads.	\$42.73
	MBT-2	Pro Co microphone bridging transformer. 150Ω/150Ω/150Ω, dual electrostatic shields, MU-metal shielding, open channel frame construction with mounting ears. 10" color coded leads.	\$60.80
	LOT-1	Pro Co line output transformer. 600Ω/600Ω or 150Ω/600Ω, open channel frame construction with mounting ears. 8" color coded leads and MU-metal shielding.	\$49.91
	LOT-M	Pro Co line output transformer 600Ω/600Ω, open channel frame, no mounting ears, 2" color coded leads. Same function as LOT-1, but smaller with less headroom.	\$32.76
	MMT-1	Pro Co microphone matching transformer. 150Ω/15kΩ, open channel frame construction, no mounting ears. 2" color coded leads. Used in 9144PC Lo- to Hi-Z Transformer assembly.	\$19.99
	CBT-1A	Pro Co direct box transformer. 20kΩ/150Ω, dual electrostatic shields, open channel frame construction with mounting ears. 4" color coded leads.	\$29.99

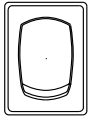
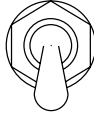

Jensen Transformers	Model Number	Description	Sug. Resale
	JT-DB-E	Jensen direct box transformer. 20kΩ/150Ω, dual electrostatic shields, MU-metal shielding, open channel frame construction with mounting ears. 4" color coded leads.	\$82.44
	JT-MBC	Jensen microphone bridging transformer. 150Ω/150Ω, dual electrostatic shields, MU-metal shielding, open channel frame construction with mounting ears. 10" color coded leads.	\$82.44
	JT-MBD	Jensen microphone bridging transformer. 150Ω/150Ω/150Ω, dual electrostatic shields, MU-metal shielding, open channel frame construction with mounting ears. 10" color coded leads.	\$139.52
	JT-11-ELCF	Jensen line output transformer. 600Ω/600Ω or 150Ω/600Ω, MU-metal shielding open channel frame construction with mounting ears. 8" color coded leads.	\$68.09







Misc. Cookbook Panel Connectors	Model Number	Captain Nema Indicator	Description	Sug. Resale
	LS-142A	H-1	1/8" mini jack, 2-cond., closed ckt., iso washers	\$0.97
	27-655	H-2	ø3.5mm mini phone jack, 3-cond., open ckt., iso washers	\$1.17
	NYS325	I-1	DIN connector, Female, 5-cond. used for MIDI	\$1.08
	SVMD-4PB	I-2	4-Pin mini DIN panel mount, female solder	\$6.42
	SVMD-6PB	I-3	6-Pin mini DIN panel mount, female solder	\$7.06
	TCS-415P	I-4	4-Pin mini DIN panel mount, female feedthru	\$19.28
	TCS-615P	I-5	6-Pin mini DIN panel mount, female feedthru	\$30.42
	119-5F	J-1	EBY (KODAK) projector connector, Female	\$23.44
	119-5M5	J-2	EBY (KODAK) projector connector, Male	\$21.60
	3505F	K-1	RCA phono jack, audio/video, iso washers	\$4.31
	161-1004 White		Mouser Barrel, rear solder RCA, insulator color White	\$2.12
	161-1002 Red		Mouser Barrel, rear solder RCA, insulator color Red	\$2.12
	161-1005 Yellow		Mouser Barrel, rear solder RCA, insulator color Yellow	\$2.12
	16PJ052BLK		Mouser Barrel, rear solder RCA, insulator color Black	\$2.12
	RJ-RU White	K-5*	Canare flush-mount RCA, insulator color White	\$13.99
	RJ-RU Red	K-6*	Canare flush-mount RCA, insulator color Red	\$13.99
	RJ-RU Yellow	K-7*	Canare flush-mount RCA, insulator color Yellow	\$13.99

Misc. Cookbook Panel Connectors	Model Number	Captain Nema Indicator	Description	Sug. Resale
	27-1085	K-3	RCA phono jack, feed thru	\$4.05
	UDBP	L-1	Universal dual binding post	\$9.72
	SE648A6-03	M-1	Modular receptacle, 6-Cond. IDC Type, standard "RJ-11"	\$12.84
	SE648A8-03	M-2	Modular receptacle, 8-Cond. IDC Type, standard "RJ-45"	\$15.99
	555050-1	M-3	Feedthrough RJ-11 phone jack	\$9.47
	SE648C8A5-03	M-4	CAT-5, 8-Cond. IDC Type, "RJ-45," Gov't standard	\$11.22
	SE648C8B5-03	M-5	CAT-5, 8-Cond. IDC Type, "RJ-45," WECO standard	\$16.00
	AMP555052-1	M-6	Feedthru, RJ-45, Cat 5 Jack	\$14.43
	CD-9240		RJ45 Feedthru	\$5.49
	10-23937		RJ45 Lats Feedthru	\$17.99
	621-12221	N-2	Rocker switch, DPDT, 5A 125 VAC	\$3.51
	629-GRS4023C-1300		Momentary rocker switch	\$5.43
	110-63	O-1	Toggle switch, SPST, toggle, 6A 125 VAC	\$6.27
	IL-250NBL3	O-2	Toggle switch, 4PDT, 15A 120 VAC	\$35.63
	CLB300G	O-3	24 volt green LED with flange	\$1.47
	CLB300R	O-4	24 volt red LED with flange	\$1.47
	7101-MYZQE	P-1	Mini-bat Toggle switch, SPDT, 5A 125 VAC	\$11.97
	AML21-CBA2AC	P-3	DPDT-Momentary, 2 amp.	\$3.13
	AML21-CBA2AD	P-4	DPDT-Alternate action, 2 amp.	\$39.03
			(if no lens is ordered, switches are automatically	

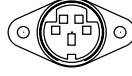
Bulk Parts

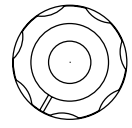
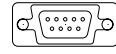
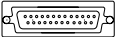

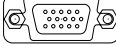
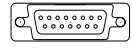
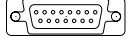
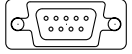

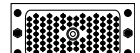
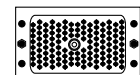









Pro Co Connectors (Cond.)

Misc. Cookbook Panel Connectors		Model Number	Captain Nema Indicator Description	Sug. Resale
	AML86	PL-1	6V bulb for AML 21 (For use with P-3 and P-4 only)	\$1.58
	AML73	PL-2	12V bulb for AML 21 (For use with P-3 and P-4 only)	\$6.27
	AML85	PL-3	24V bulb for AML 21 (For use with P-3 and P-4 only)	\$1.87
	AML-C10W	PL-4	White lens for AML 21 (For use with P-3 and P-4 only)	\$3.79
	AML-C10Y	PL-5	Yellow lens for AML 21 (For use with P-3 and P-4 only)	\$3.79
	AML-C10R	PL-6	Red lens for AML 21 (For use with P-3 and P-4 only)	\$3.79
	AML-C10G	PL-7	Green lens for AML 21 (For use with P-3 and P-4 only)	\$3.79
	CH7562K4	P-12	DPDT-On/Off/On 15 amp toggle	\$30.23
	CH7565K6	P-13	DPDT-On/On 15 amp toggle	\$15.35
	CK7201P3YZQE	P-14	DPDT On/On flat toggle	\$25.20
	CK7203P3YZQE	P-15	DPDT On/Off/On flat toggle	\$21.60
	P2011U	P-17	Switchlock, DPDT, black nylon, 4a 125 VAC, 2 position	\$13.70
	81F1315	P-18	C&K latching, Y-series key-switch	\$43.67
	D4C0206N	P-19	Electroswitch 2pol/6pos or 1pol/12pos rotary switch	\$55.31
	BCJ-JR	Q-1	Canare BNC feedthru panel jack with IU-7/16 isolation gasket	\$11.54
	BCJ-R/1	Q-2	Canare BNC solder panel jack with IU-7/16 isolation gasket	\$10.48
	BCJ-JRU	R-1	Canare flush-mount isolated BNC feedthru	\$14.80

Misc. Cookbook Panel Connectors		Model Number	Captain Nema Indicator Description	Sug. Resale
	GF81C	S-1	Blonder-Tongue "F" connector, feedthru, iso washers	\$4.18
	TCS-7649	S-2	4-Pin mini DIN panel mount, female	\$5.17
	PKD-10KLIN	T-1	10K mini pot. with knob .75" dia., 1-10 dial	\$31.23
	10LC2	T-2	Lowell Attenuator, 10 watt	\$48.39
	35LC2	T-3	Lowell Attenuator, 35 watt	\$57.49
	100LC2	T-6	Lowell Attenuator, 100 watt	\$65.11
	PKES-10K	T-5	10K linear pot. with knob .90" dia.	\$25.75
	DE-9F	Y-1	9 Contact, socket connector, solder type	\$1.49
	DB-25F	Y-2	25 Contact, socket connector, solder type	\$2.96
	DB-25M	Y-3	25 Contact, pin connector, solder type	\$1.52
	CD-9532HD	Y-4	15 Contact, Hi-density pin connector, feedthru type	\$7.38
	CD-9515HDS	Y-5	15 Contact, Hi-density pin connector, solder type	\$2.04
	DA-15S	Y-6	15 Contact, pin connector, solder type	\$6.42
	CD9530	Y-7	9 Contact, socket connector, feedthru type	\$4.85
	516-056-402	Z-1	EDAC, 56 Pin, female panel mount, less contacts	\$12.21
	516-090-402	Z-2	EDAC, 90 Pin, female panel mount, less contacts	\$14.31
	8016-120-607Z-4		Helix, 120 Contact, female panel mount, less contacts	\$25.34

Bulk Parts

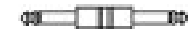
Pro Co Adapters

Pro Co "PC" Series Adapters		Model Number	Description	Sug. Resale
	330PJPC		Adapter, (2) RCA jacks to (1) 1/4" phone plug	\$2.99
	336APC		Adapter, Phone jack to RCA plug	\$2.57
	340PC		Adapter, (2) 1/4" phone jacks to (1) 1/4" mono plug	\$4.39
	341PC		Adapter, (2) stereo 3.5mm jacks to (1) 1/4" stereo plug	\$2.51
	342PC		Adapter, 1/4" stereo phone jack to stereo 3.5mm plug	\$2.15
	343PC		Adapter, stereo 3.5mm jack to 1/4" stereo phone plug	\$2.08
	344PC		Adapter, (2) stereo 1/4" phone jacks to (1) 1/4" stereo plug	\$1.99
	345APC		Adapter, RCA jack to 1/4" phone plug	\$1.66
	349APC		Coupler, RCA jack to RCA jack	\$2.29
	330F1PC		(2) RCA jacks to (1) RCA plug, 4" flexible cables	\$2.92
	330F2PC		Adapter, 1 RCA plug to 1 RCA jack and 1 RCA plug	\$2.64
	361APC		Coupler, 1/4" phone jack to 1/4" phone jack	\$3.69
	363PC		Coupler, 1/4" phone plug to 1/4" phone plug	\$1.99
	364APC		Adapter, 3.5mm jack to 1/4" phone plug	\$1.99

USB Panel Connectors		Model Number	Description	Sug. Resale
	ECJ504UA		USB A panel connector	\$20.99
	ECJ504UB		USB B panel connector	\$20.99
	ECJ504-UAB		USB A to B panel feedthru connector	\$20.99

Fiber Optic Panel Connectors		Model Number	Description	Sug. Resale
	502750-1		ST type	\$11.99
	504640-1		SC type	\$20.99

ConcertMASTER Connectors		Model Number	Description	Sug. Resale
CM54LF06			Line female with locking ring, 54 pins	\$135.10
CM150LF06			Line female with locking ring, 150 pins	\$152.20
CM201LF06			Line female with locking ring, 201 pins	\$215.00
CM54LM01			Line male without locking ring, 54 pins	\$137.52
CM150LM01			Line male without locking ring, 150 pins	\$155.78
CM201LM01			Line male without locking ring, 201 pins	\$190.00
CM54PF26			Panel female with locking ring, 54 pins	\$129.66
CM150PF26			Panel female with locking ring, 150 pins	\$133.66
CM201PF26			Panel female with locking ring, 201 pins	\$196.46
CM54PM02			Panel male without locking ring, 54 pins	\$58.34
CM150PM02			Panel male without locking ring, 150 pins	\$66.46
CM201PM02			Panel male without locking ring, 201 pins	\$100.66
CMC06-54			Metal protective cap for 06/26 versions, 54 pins	\$74.10
CMC06-85			Metal protective cap for 06/26 versions, 150 pins	\$92.20
CMC06-26-201			Metal protective cap for 06/26 versions, 201 pins	\$97.20
CMC01-02-54			Metal protective cap for 01/02 versions, 54 pins	\$50.82
CMC01-02-85			Metal protective cap for 01/02 versions, 150 pins	\$78.16
CMC01-02-201			Metal protective cap for 01/02 versions, 201 pins	\$78.16
GMC-16P-13			Male contacts for 54 pin version	\$1.42
GFC-16S-13			Female contacts for 54 pin version	\$2.40
GMC-18P			Male contacts for 150 pin version	\$1.12
GFC-18S			Female contacts for 150 pin version	\$2.34

Pro Co MASS Connectors		Model Number	Description	Sug. Resale
	CM176M		176-pin cable connector	\$598
	CM176P		176-pin panel connector	\$558

DBA and DBA/H		Model Number	Description	Sug. Resale
	DBA		Covers for Neutrik "D" style punchouts. DBA has no hole.	\$2.00
	DBA/H		Has a 3/8" hole to accommodate a 1/4" or RCA panel connector when required.	\$4.00