

FIXED MOUNTS

QM100 F FIXED MOUNT

- 40-lb. maximum weight capacity
- Slide together quick mount for LCD displays
- Designed to easily install LCD panels on walls
- "Hot swap" capable
- Will accept security hardware
- VESA 75/100 compliant
- Grey

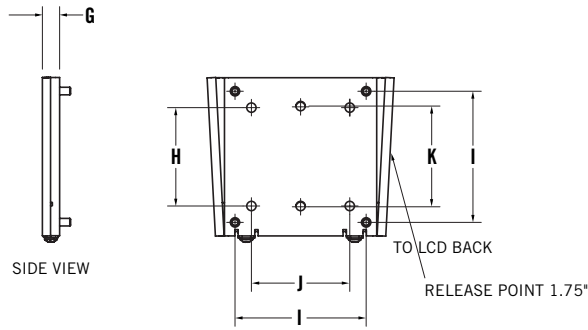
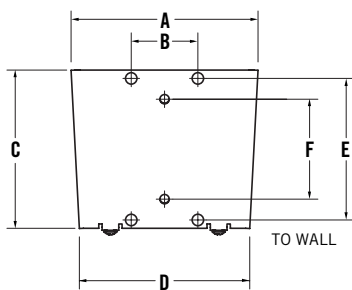

DIMENSIONS

A	5.60"	142.24 mm
B	2.00"	50.80 mm
C	4.75"	120.65 mm
D	5.11"	129.79 mm
E	4.25"	107.95 mm
F	3.00"	76.20 mm
G	0.52"	13.21 mm
H	2.95"	75.00 mm
I	3.94"	100.00 mm
J	2.95"	75.00 mm
K	3.02"	76.71 mm

HARDWARE KIT

Qty	Description
4	Phillips screws M4 x 8mm
4	Phillips screws M5 x 8mm
4	Phillips screws M4 x 12mm
4	Phillips screws M5 x 12mm
2	Phillips wood screws #12 x 2"
2	"Toggleler" anchors

QM300 F FIXED MOUNT

- 175 lb. maximum capacity
- Slide together quick mount for plasma panels
- Designed to easily install plasma panels on the wall
- "Hot swap" capability
- Will accept security hardware
- Grey or black

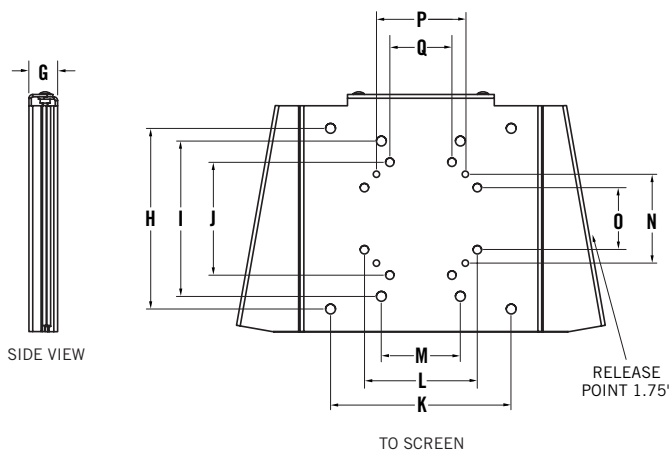
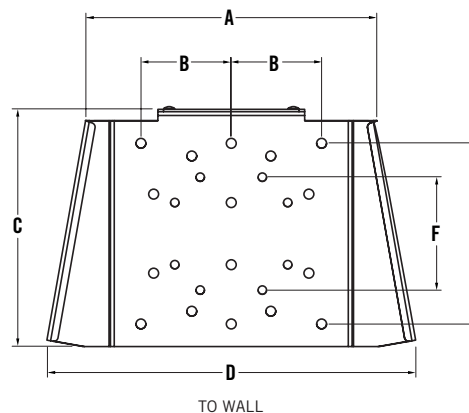
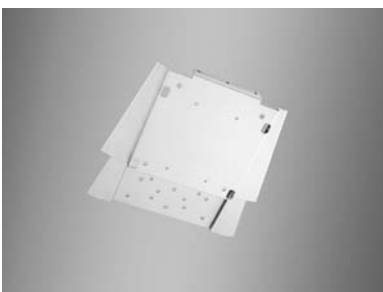

DIMENSIONS

A	12.90"	327.69 mm
B	4.00"	101.60 mm
C	10.51"	266.83 mm
D	16.33"	414.76 mm
E	8.00"	203.20 mm
F	5.00"	127.00 mm
G	1.27"	32.26 mm
H	8.01"	203.33 mm
I	6.88"	174.63 mm
J	5.00"	127.00 mm
K	8.00"	203.20 mm
L	5.00"	127.00 mm
M	3.50"	88.90 mm
N	3.94"	100.00 mm
O	2.75"	69.85 mm
P	3.94"	100.00 mm
Q	2.75"	69.85 mm

HARDWARE KIT

Qty	Description
4	Lag screw 3/8 x 3 1/2"
4	Washers 3/8ID x 13/16OD
4	Button head machine screw 3/8-16 x 1/2"
4	Nylon jam nut 3/8-16