

75/100 FD FLIP DOWN MOUNT

75/100 FD FLIP DOWN MOUNT

- 40 lb. maximum weight capacity
- Flip down/under the cabinet mount for LCD panels
- Allows LCDs to be flipped up and stored when not in use
- Allows for tilt and swivel of LCD panel for optimum viewing
- VESA 75/100 compliant
- Durable grey powder coat finish

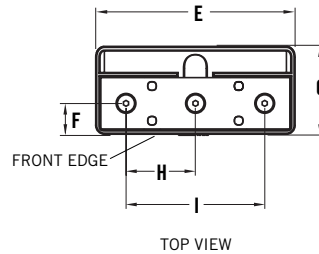

DIMENSIONS		
A	11.05"	280.66 mm
B	.691"	17.54 mm
C	10.52"	267.18 mm
D	.612"	15.54 mm
E	5.75"	146.05 mm
F	.92"	23.37 mm
G	2.56"	65.12 mm
H	2.00"	50.80 mm
I	4.00"	101.60 mm
J	.98"	24.89 mm
K	2.95"	75.00 mm
L	3.94"	100.00 mm
M	.75"-1.0"	19.05-25.4 mm

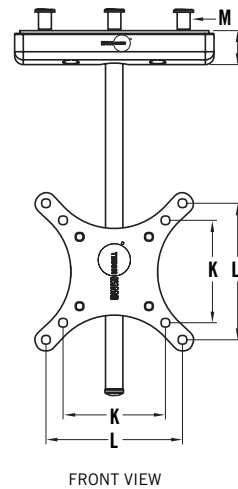
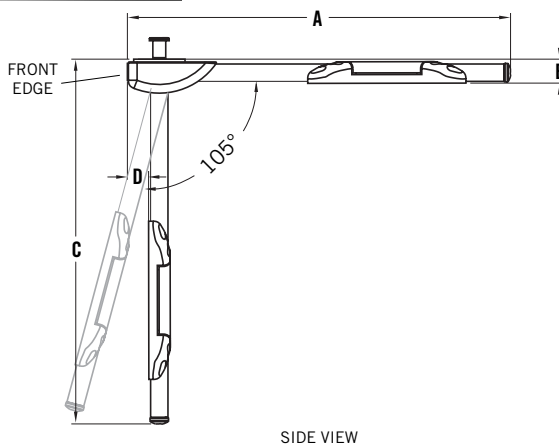

HARDWARE KIT

Qty	Description
4	Phillips screws M4 x 8mm
4	Phillips screws M5 x 8mm
4	Phillips screws M4 x 12mm
4	Phillips screws M5 x 12mm
1	Allen wrench 3/16 x 4 1/2
1	Allen wrench 5/32 x 4 1/2
2	Cable tie 1/16 x 3 1/2 WHT

TILT PA TILT PIPE ADAPTER MOUNT

TILT PA TILT PIPE ADAPTER MOUNT

- 175 lb. maximum weight capacity
- Provides a mounting point for new/existing pipe drops from ceiling or rafters
- Perfect for conference/board rooms
- Fits 1 1/2" standard (NPT) pipe thread
- Allows 45/15° tilt of flat panel for optimum viewing
- Durable black powder coat finish
- May be used in conjunction with QM300 F for "hot swap" capability

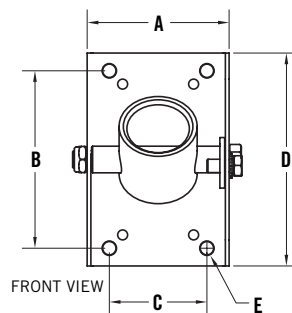

DIMENSIONS		
A	4.00"	101.60 mm
B	5.00"	127.00 mm
C	2.75"	69.85 mm
D	6.00"	152.40 mm
E	.375"	9.52 mm
F	4.00"	101.60 mm
G	1.25"	31.75 mm

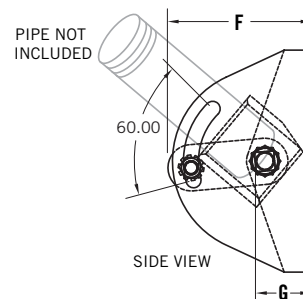
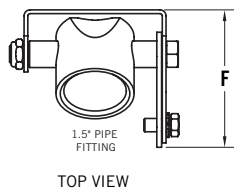

HARDWARE KIT

Qty	Description
4	Button head machine screw 3/8-16 x 1/2"
4	Nylon jam nut 3/8-16