

## 48ARM

### 48 ARTICULATED RETRACTABLE MOUNT

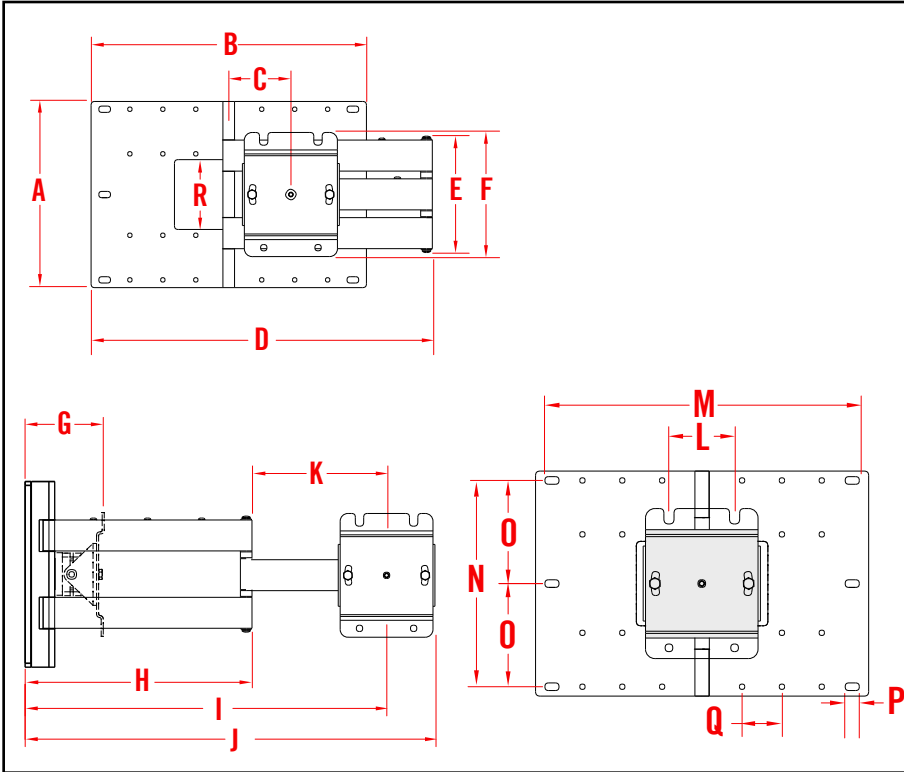

#### TECHNICAL SPECIFICATIONS

A	12.00"	304.80mm
B	18.38"	466.73mm
C	3.88"	98.55mm
D	variable	variable
E	7.50"	190.50mm
F	8.00"	203.20mm
G	4.40"	111.76mm
H	14.75"	374.65mm
I	23.75"	603.25mm
J	26.50"	673.10mm
K	8.25"	209.55mm
L	3.50"	88.90mm
M	17.00"	432.00mm
N	11.00"	279.40mm
O	5.50"	139.70mm
P	1.00"	25.40mm
Q	2.00"	50.80mm
R	4.50"	114.30mm

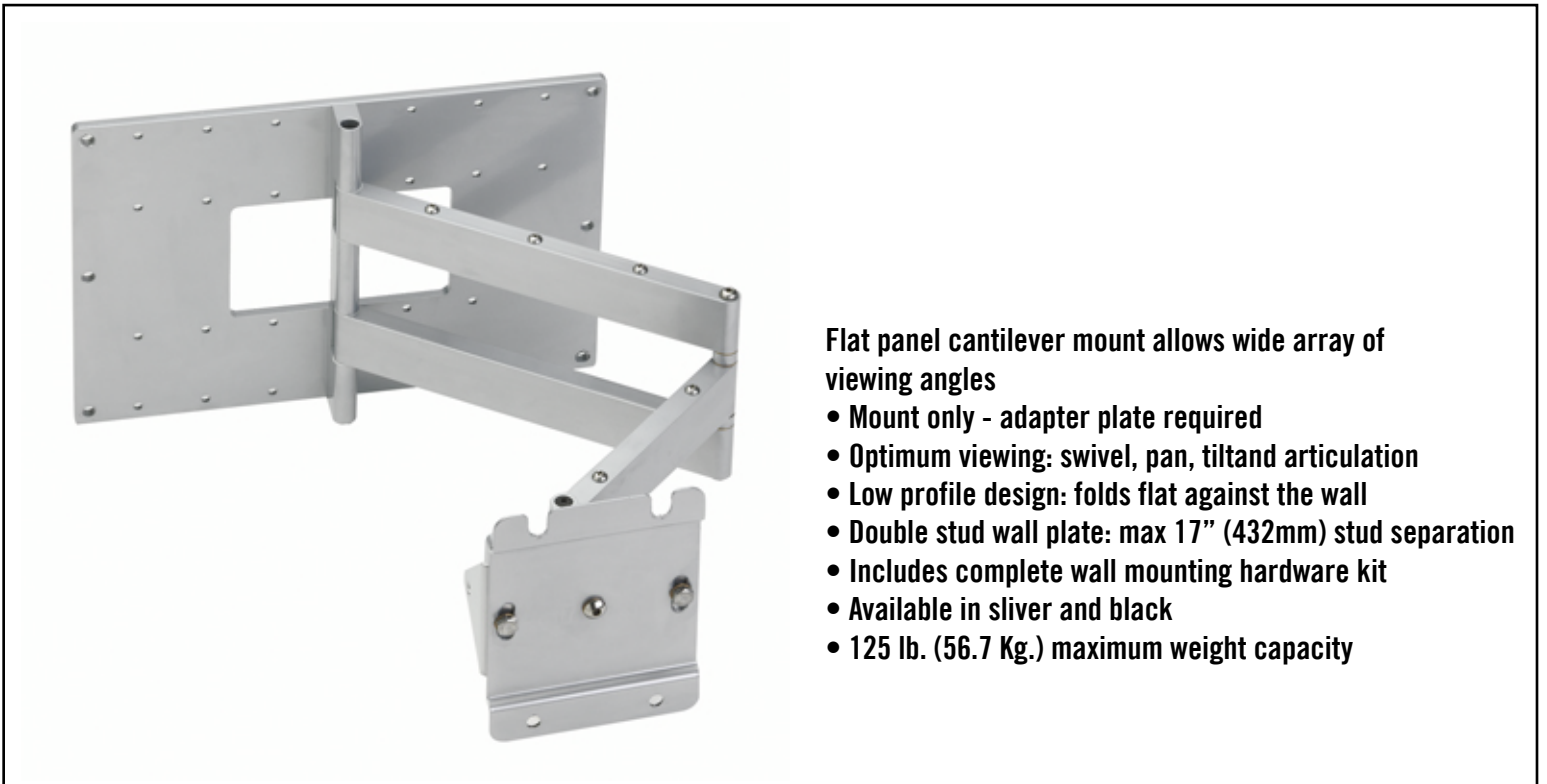

Flat panel cantilever mount allows wide array of viewing angles

- Mount only - adapter plate required
- Optimum viewing: swivel, pan, tilt and articulation
- Low profile design: folds flat against the wall
- Double stud wall plate: max 17" (432mm) stud separation
- Includes complete wall mounting hardware kit
- Available in silver and black
- 125 lb. (56.7 Kg.) maximum weight capacity