

MiniMAC Maestro

user manual

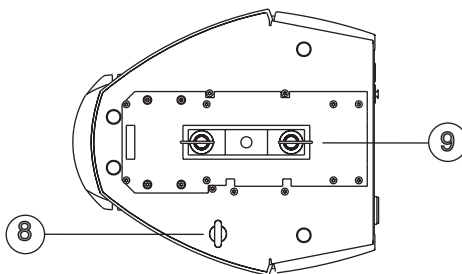

- 1 data connection
- 2 base fan
- 3 head fan
- 4 AC input & main fuse
- 5 cover locks
- 6 rear cover
- 7 control panel
- 8 eye bolt for safety cable
- 9 Omega clamp attachment bracket

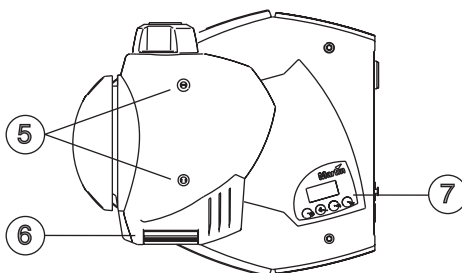
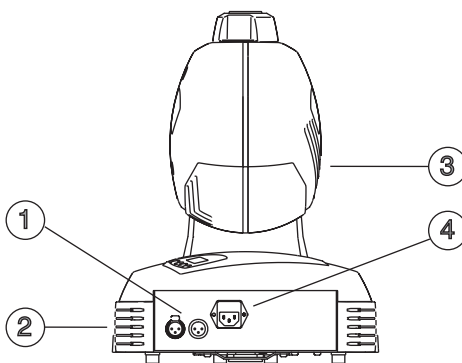

©2000-2002 Martin Professional A/S, Denmark.

All rights reserved. No part of this manual may be reproduced, in any form or by any means, without permission in writing from Martin Professional A/S, Denmark.

Printed in Denmark.

P/N 35000091, Rev F

INTRODUCTION	5
Safety information	5
Unpacking	6
AC POWER	7
INSTALLATION	9
Location and orientation	9
Key dimensions	9
Installation options	11
CONTROL PANEL	14
Personalities	19
Readouts	20
Test programs	20
Upload mode	20
Manual control	20
Adjustment control	21
CONTROLLER OPERATION	22
Data connection	22
Mode selection	23
Address selection	24
Controllable effects	24
STAND-ALONE OPERATION	26
Control modes	26
Fixture setup	27
About scene timing	29
Menu commands	30
MC-X execution	32
Remote control commands	32
Programming example	35
LAMP	37
Compatible lamps	37
GOBOS	39
Custom gobos	39
Image size	39
Installation	40
Suggested suppliers	41
BASIC SERVICE	42
Cleaning	42
Installing software	43

Replacing fuses	44
Inserting or changing a color filter	45
TROUBLESHOOTING	46
DMX PROTOCOL.	48
SPECIFICATIONS	50

INTRODUCTION

Thank you for selecting the Martin MiniMAC Maestro. This automated luminaire provides 4 rotating slots for glass or metal image gobos, 16-bit gobo indexing, motorized focus, high-speed mechanical shutter, 540° of pan by 270° of tilt, 3-digit LED control panel; DMX, stand-alone, and remote control options; precision optics, and switch-selectable power supply settings.

SAFETY INFORMATION

Warning! *This product is for professional use only. It is not for household use.*

This product presents risks of lethal or severe injury due to fire and heat, electric shock, ultraviolet radiation, lamp explosion, and falls. **Read this manual** before powering or installing the fixture, follow the safety precautions listed below and observe all warnings in this manual and on the fixture. If you have questions about how to operate the fixture safely, please contact your Martin dealer or call the Martin 24-hour service hotline at +45 70 200 201.

To protect yourself and others from electric shock

- Disconnect the fixture from AC power before removing or installing the lamp, fuses, or any part, and when not in use.
- Always ground (earth) the fixture electrically.
- Use only a source of AC power that complies with local building and electrical codes and has both overload and ground-fault protection.
- Do not expose the fixture to rain or moisture.
- Refer all service to a Martin service technician.

To protect yourself and others from UV radiation and lamp explosion

- Never operate the fixture with missing or damaged lenses and/or covers.
- When replacing the lamp, allow the fixture to cool for at least 5 minutes before opening the fixture or removing the lamp. Protect your hands and eyes with gloves and safety glasses.

- Do not stare directly into the light. Never look at an exposed lamp while it is lit.
- Replace the lamp if it becomes defective or worn out.

To protect yourself and others from burns and fire

- Never attempt to bypass the thermostatic switch or fuses. Always replace defective fuses with ones of the specified type and rating.
- Keep all combustible materials (for example fabric, wood, paper) at least 0.3 meters (12 inches) away from the fixture. Keep flammable materials well away from the fixture.
- Do not illuminate surfaces within 0.3 meters (12 inches) of the fixture.
- Provide a minimum clearance of 0.1 meters (4 inches) around fans and air vents.
- Never place filters or other materials over the lens.
- The exterior of the fixture can reach temperatures up to 55° C (131° F). Allow the fixture to cool before handling.
- Do not modify the fixture or install other than genuine Martin parts.
- Do not operate the fixture if the ambient temperature (T_a) exceeds 40° C (104° F).

To protect yourself and others from injury due to falls

- When suspending the fixture above ground level, verify that the structure can hold at least 10 times the weight of all installed devices.
- Verify that all external covers and rigging hardware are securely fastened and use an approved means of secondary attachment such as a safety cable.
- Block access below the work area whenever installing or removing the fixture.

UNPACKING

The packing material is carefully designed to protect the fixture during shipment - always use it to transport the fixture.

The MiniMAC Maestro comes with:

- Philips CDM-SA/T 150W discharge lamp (installed)
- 3 m, 3-pin IEC mains cable
- 5 m, black, 3-pin XLR data cable
- Attachment bracket for mounting clamp
- Eye bolt for safety cable
- User manual
- Fuse

AC POWER

The MiniMAC Maestro has switch-selectable settings to configure the power supply for local conditions. The factory-default setting is indicated on the serial number label. Always use the setting that is closest to the local AC supply.

Warning! *For protection from electric shock, the fixture must be grounded (earthed). The power supply shall have overload and ground-fault protection.*

Important! *Install fuse and verify that power supply settings match local AC supply before use.*

To change the voltage setting

- 1 Disconnect the fixture from power.
- 2 Remove the 4 base cover bolts with a 4 mm Allen wrench. Move the cover out of the way of the switches without disconnecting wires.

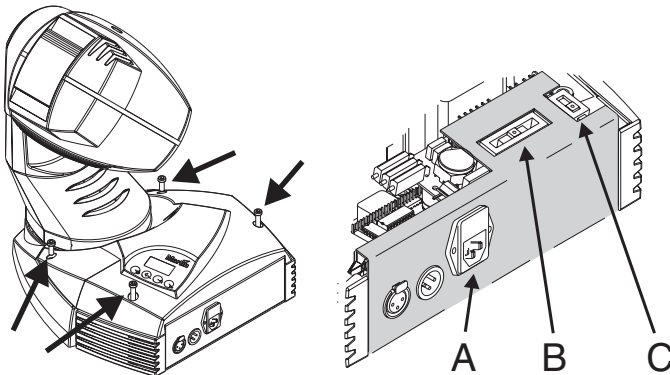

- 3 Set the 5-position switch (A) to the setting closest to the AC voltage. Use the higher setting if the voltage is halfway between 2 settings. For example, use the 230 V setting instead of the 210 V setting for operation with 220 V power.
- 4 Set the 2-position switch (B) to the AC frequency (50 / 60 Hz).
- 5 Replace the cover and apply a new power setting label to the serial number label.

To install the main fuse

Fuses are provided for 100 - 130 V and 200 - 250 V operation. *Use only the fuse specified for the operating voltage.*

- 1 Locate the bag containing the fuse for your AC voltage. Insert the fuse in the fuse holder. The holder may be packed with the other fuse.
- 2 Remove the label covering the mains input socket.
- 3 Insert the fuse holder in the empty slot in the mains input socket (C).

To install a plug on the power cable

The power cable must be fitted with a grounding-type cord cap that fits your power distribution system. Consult an electrician if you have any doubts about proper installation.

- Following the cord cap manufacturer's instructions, connect the yellow and green wire to ground (earth), the brown wire to live, and the blue wire to neutral. The table below shows some pin identification schemes.

Wire	Pin	Marking	Screw color
brown	live	"L"	yellow or brass
blue	neutral	"N"	silver
yellow/green	ground		green

Table 1: Cord cap connections

To apply power

Warning! *The power cables must be undamaged and rated for the electrical requirements of all connected devices.*

Important! *Powering through a dimmer system can damage the fixture.*

- Connect the prepared cable to the mains input socket and the AC mains distribution system. Do not connect the fixture to a dimmer system.

INSTALLATION

LOCATION AND ORIENTATION

For safe operation, install the MiniMAC Maestro in a location where

- it is at least 0.3 meters (12 inches) away from illuminated surfaces and combustible materials.
- it is not easily touched or bumped.
- it is protected from rain and moisture.
- there is at least 0.1 meters (4 inches) clearance around the fans and air vents.
- there are no flammable materials nearby.

The MiniMAC Maestro may be installed in any orientation.

The intense light can burn or melt parts within a distance of 0.3 meters (12 inches). The MiniMAC Maestro is programmed to close its shutter if it illuminates its own base for more than 10 seconds. *When installing fixtures side-by-side, avoid illuminating one fixture with another.*

KEY DIMENSIONS

Head movement angles

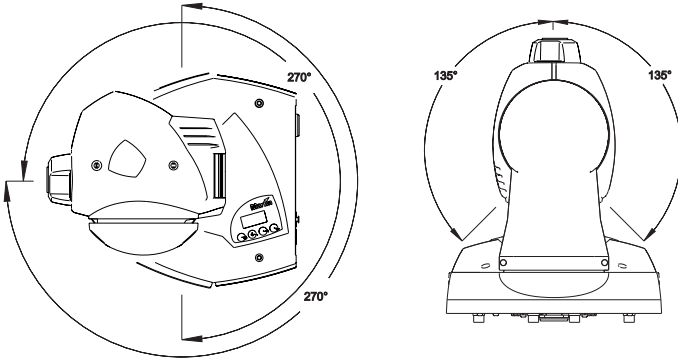

Exterior

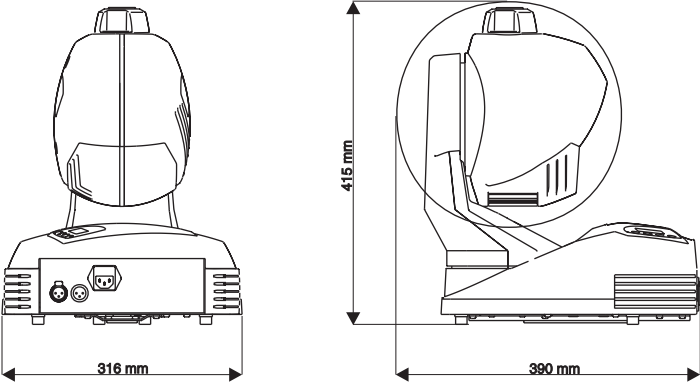

Base

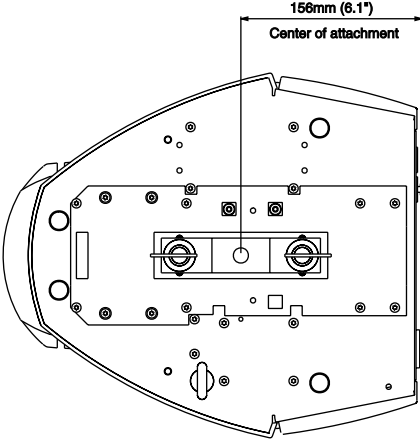

Attachment point relationship to center of movement

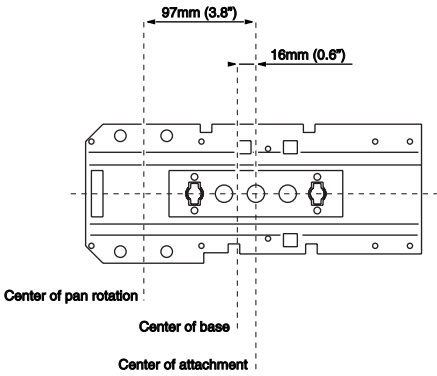

INSTALLATION OPTIONS

The MiniMAC Maestro can be rigged using a clamp, a flush mount bracket, or a pantograph.

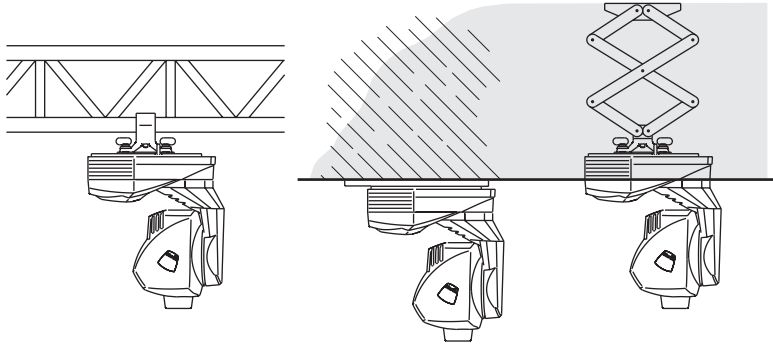

Clamp

The MiniMAC Maestro includes a bracket for attaching a rigging clamp with 12 mm (1/2 in.) hardware. Clamps available from Martin are listed on page 51.

TO RIG THE FIXTURE

WARNING! *Screw the included eye bolt securely into the base and fasten a safety cable to the eye bolt.*

- 1 Verify that the clamp is undamaged and can bear at least 10 times the weight of the fixture. Verify that the structure can bear at least 10 times the weight of all installed fixtures, clamps, cables, auxiliary equipment, etc.
- 2 Bolt a clamp to the included bracket with a grade 8.8 (minimum) M12 bolt and lock nut, or as recommended by the clamp manufacturer, through the 13 mm hole in the bracket.
- 3 Align the bracket with the keyholes in the base. Insert both locking pins into the holes and turn both levers a full 1/4 turn clockwise to lock. *The fasteners are locked only when turned fully clockwise.*
- 4 Screw the eye bolt securely into the base where shown below.
- 5 Block access below the work area.
- 6 Working from a stable platform, clamp the fixture to the structure.

- 7 Fasten a safety cable that can bear at least 10 times the weight of the fixture to the structure and the eye bolt.

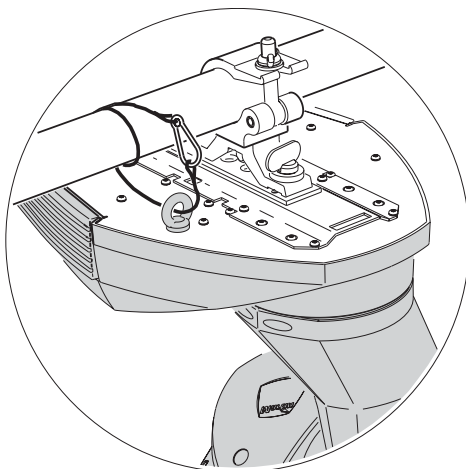

Flush mount bracket

Where no trussing system is available, you can use a special flush mount bracket that is available for the MiniMAC series. It is a simple metal bracket, which enables the MiniMAC to be flush mounted on a standard ceiling or wall. It provides a very discrete installation, with a very limited air gap between the product and the ceiling or wall. The bracket is designed so that one person can easily make the installation alone.

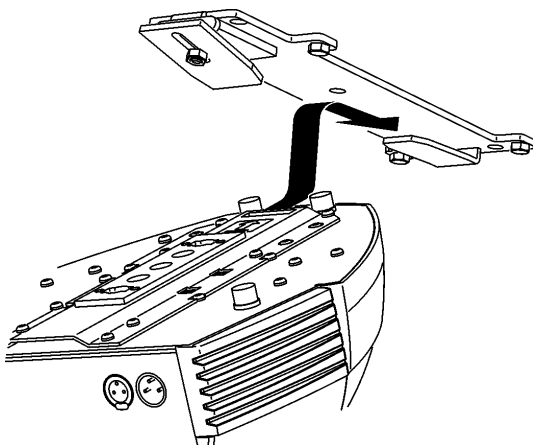

The flush mount bracket can be ordered separately from a Martin dealer (P/N 91606009).

Pantograph

Another option for mounting the MiniMAC Maestro is the Martin Pantograph that specifically designed for hanging Martin luminaires from ceilings or other load-bearing structural elements. It may be used to suspend a fixture weighing up to 22 kg (48 lbs), and provides a drop from the ceiling to the attachment point of 12 to 62 cm (4.75 - 24.4 in.).

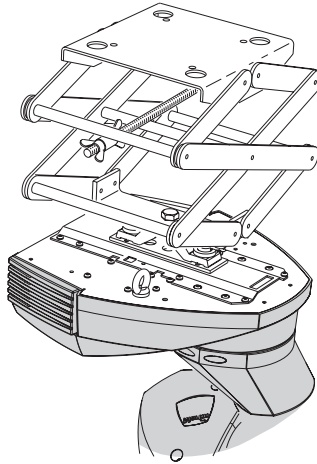

The pantograph can be ordered separately from a Martin dealer (P/N 91602006).

Ceiling template

If you are mounting the MiniMAC Maestro through a ceiling then a template that can be used to cut out the shape of the fixture is available from the MiniMAC Maestro support page on the Martin support site (<http://www.martin.dk/service/service.asp>).

CONTROL PANEL

The control panel is used to set user options; display lamp hours, DMX values, and other information; perform tests, and operate the fixture in stand-alone mode. This section describes the general options available from the control panel. Additional options are described in later sections.

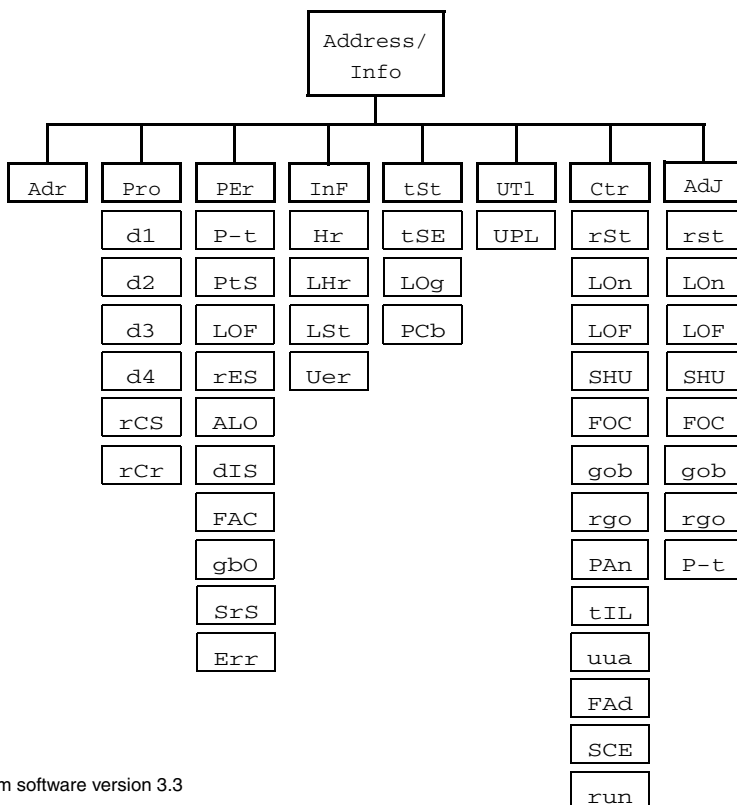

Valid from software version 3.3

Level 1	Level 2	Level 3	Options	Effect (default settings bold)
Adr	-	-	1-512	Set fixture address
Pro	-	-	d1	Set DMX mode 1 (8-bit, tracking)
			d2	Set DMX mode 2 (16-bit, tracking)
			d3	Set DMX mode 3 (8-bit, tracking/vector)
			d4	Set DMX mode 4 (16-bit, tracking/vector)
			rCS	Set remote control "send" mode
			rCr	Set remote control "receive" mode
PEr	P-t	P t	On	Map pan to tilt channel and vice versa.
			OFF	Select normal pan and tilt control.
		PIn	ON	Reverse pan control (right → left).
			OFF	Select normal pan (left → right).
		tIn	ON	Reverse tilt control (down → up).
			OFF	Select normal tilt (up → down).
	PtS	-	FS t	Optimize movement for speed.
			SLO	Optimize movement for smoothness.
	LOF	-	ON	Enable lamp-off without confirmation.
			OFF	Require confirmation of lamp-off.
	rES	-	ON	Enable reset without confirmation.
			OFF	Require confirmation of reset command
	ALO	-	ON	Strike lamp automatically within 90 seconds.
			OFF	Strike lamp from controller.
	dIS	-	ON	Keep display lit.
			OFF	Turn display off 2 minutes after key press.
	FAC	-	SUr	Restore default personality settings.
	gbo	-	ON	Blackout light while gobo changes.
			OFF	Disable gobo blackout feature.
	SrS		ON	Enable the store remote status feature.
OFF			Disable the store remote status feature.	
Err		ON	Error messages are always displayed.	
		OFF	Error messages are not displayed.	

Table 2: Control menu

Level 1	Level 2	Level 3	Options	Effect (default settings bold)	
InF	Hr	tot	0-9999	Read power-on hours since fabrication.	
		rES	0-9999	Read power-on hours since counter was reset.	
	LHr	tot	0-9999	Read lamp hours since fabrication.	
		rES	0-9999	Read lamp hours since counter was reset.	
	LSt	tot	0-9999	Read lamp strikes since fabrication.	
		rES	0-9999	Read lamp strikes since counter was reset.	
UEr	-	1.0-99.9	Read firmware version number.		
tSt	tSE	-	run	Execute a general test of all effects.	
	Log	-	-	Not used.	
	PCb	-	SUr	Execute circuit board test. <i>For service use only.</i>	
UtI	UPL	-	SUr	Manually engage upload mode. See page 43.	
Ctr	rst	-	-	Reset effects to home position.	
	LOn	-	-	Turn on lamp.	
	LOF	-	-	Turn off lamp.	
	SHU	-	Opn		Open shutter.
			CLO		Close shutter.
			FSt		Set fast strobe.
			nor		Set medium strobe.
SLO				Set slow strobe.	
		rnd		Set random strobe.	

Table 2: Control menu

Level 1	Level 2	Level 3	Options	Effect (default settings bold)
Ctr	FOC	-	0-255	Set focus (far to near).
	gob	ind	g1-g4	Select gobo and indexed rotation.
		rot	g1-g4	Select gobo and continuous rotation.
	rgo	Fin	0-255	Set fine gobo index. Ind must be selected under gob .
		CrS	0-255	Set coarse gobo index. Ind must be selected under gob .
		-	0-255	Set gobo rotation speed and direction. rot must be selected under gob .
	PAn	Fin	0-255	Set fine pan position.
		CrS	0-255	Set coarse pan position.
	tIL	Fin	0-255	Set fine tilt position.
		CrS	0-255	Set coarse tilt position.
	uuA	-	0-600	Set wait time in seconds.
	FAd	-	0-120	Set transition time in seconds.
	SCE	-	Sto	Save changes to current scene.
			Add	Save new scene to end of sequence.
			InS	Save new scene before current scene.
			dEL	Delete the current scene.
			nE	Call the next scene.
			PrE	Call the previous scene.
			CLr	Delete all scenes.
	run	-	OFF	Disable stand-alone operation.
			Sin	Set stand-alone operation on a single fixture.
Snd			Set fixture to be the master in multiple fixture stand-alone mode. <i>Only one fixture on a link may be the master.</i>	
SYn			Set fixture to synchronize with master in multiple fixture stand-alone mode. (Executes own scenes.)	

Table 2: Control menu

Level 1	Level 2	Level 3	Options	Effect (default settings bold)
Adj	rst	-	-	Reset effects to home position.
	LOn	-	-	Turn on lamp.
	LOF	-	-	Turn off lamp.
	SHU	-	OPn	Open shutter.
			CLO	Close shutter.
	FOC	-	FAr / nEA	Move focus lens to limits.
	gob	-	g1 / g4	Select gobo.
	rgo	-	g1 - g4	Select gobo and rotation.
P-t	-	P1 - P7	Move head to neutral and extreme positions.	

Table 2: Control menu

To navigate the control menu

- In DMX mode, the control panel displays the fixture address at the top of the menu. In Stand-alone mode, the current scene number is displayed after the letter P. If there are any error messages (page 46) these are displayed as well. To get to the top of the menu, press [menu] repeatedly. From the top, press [menu] to enter the main menu. Press [up] or [down] to scroll through menus and press [enter] to view submenus. To activate a setting or function, press [enter]. To return to the previous menu or to escape without making a selection, press [menu].

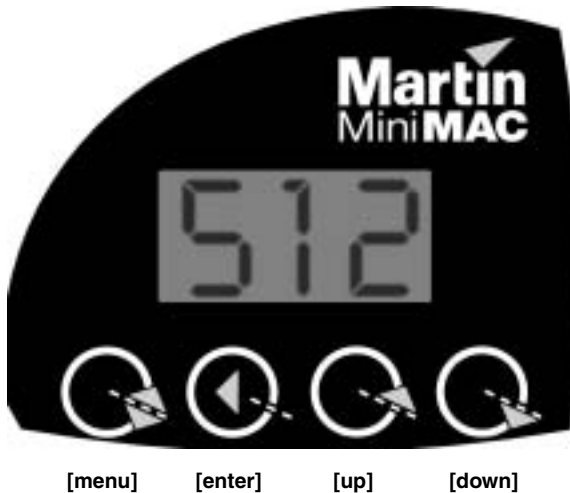

To invert the display

- Press [up] and [down] at the same time.

PERSONALITIES

The following settings are available to modify fixture behavior.

Pan/tilt swap: Map pan to the tilt channel and tilt to the pan channel to provide more intuitive control of fixtures mounted sideways.

Inverse pan: Flip pan movement to right-to-left instead of left-to-right.

Inverse tilt: Flip tilt movement to down-to-up instead of up-to-down.

Pan/tilt speed: Optimize motor control for speed or smoothness.

DMX lamp-off: Disable the lamp-off command unless image 4 is selected and focus is set to closest (100 percent).

DMX reset: Disable the reset command unless image 4 is selected and focus is set to closest (100 percent).

Automatic lamp-on: Strike lamps automatically within 90 seconds of applying power to the fixture. Timing is staggered to prevent excessive current draw.

Display: Turn off the display 2 minutes after the last key press or leave it on. This setting will be overridden by error messages.

Gobo blackout: Blackout the light automatically - by closing shutter - to make gobo changes invisible.

Store remote status: When active, this option links the Run/Stop action on the IR remote to the execution settings for stand-alone operation. When you select run or stop via the remote control this will update the fixture's execution settings. This enables you to – via the IR remote - switch on or off the automatic starting of stand-alone operation when the fixture is powered on.

Errors message toggle: This enables error messages to be switched on or off. This enables, for example, the continued programming of a fixture that has a non-critical error. The default setting is On, which means that errors messages will always be displayed.

To select a personality setting

- Scroll to **P E R** in the main menu, press [enter], scroll to the desired personality, and press [enter]. Select the desired option and press [enter]. Refer to Table 2.

To restore default personality settings

- Scroll to **P E R** in the main menu, press [enter], and scroll to **F A C**. Press [enter] twice to confirm and execute the command.

READOUTS

The MiniMAC Maestro provides readouts to track usage, maintenance intervals, lamp life, and software version. Values from 1000 to 9999 are automatically scrolled and counters roll over to 0 when they reach 10,000.

To display or reset a readout

- 1 Scroll to `Inf` in the main menu, press [enter] and scroll to the desired readout. Press [enter] and scroll to the desired option. Press [enter] to display the information.
- 2 (Optional) To reset a counter, press [up] until the readout displays 0.

TEST PROGRAMS

Test sequence: The test sequence allows you to check all effects quickly. At the end of the test cycle, effects return to their home position briefly before the test repeats. To run the test, navigate to `tSt / tSE / rUn` and press [enter]. To stop the test, press [menu].

PCb: For service use only. *Executing this test with motors connected may cause damage to the circuit board.*

To test DMX control values

- 1 On the controller, program a set of commands for the fixture.
- 2 Scroll to `tSt` in the main menu, press [enter] and scroll to `Log`. Press [enter].
- 3 Press [enter] to display the start code. The start code must be 0. Press [menu].
- 4 Scroll through the effects and press [enter] to display the DMX values received. Compare the values with the DMX protocol.

UPLOAD MODE

Software upload mode is normally engaged automatically. Use this option only if automatic upload fails. See “Installing software” on page 43.

MANUAL CONTROL

The manual control menu (`Ctr`) provides limited manual operation and is used to program and execute scenes as in Stand-alone mode.

ADJUSTMENT CONTROL

The adjustment menu (A d J) provides manual control for service use.

CONTROLLER OPERATION

This section describes setup and operation with DMX controllers.

Important! *Controller operation is disabled if stand-alone mode is enabled.*

DATA CONNECTION

RECOMMENDED CABLE

Reliable data communication begins with the right cable. Most microphone cable does not transmit digital data reliably over long runs. For best results, use shielded, twisted-pair cable designed for RS-485 applications with low capacitance and a characteristic impedance of 85 to 150 ohms. The minimum wire size is 0.2 mm (24 AWG) for runs up to 300 meters (1000 ft.) and 0.322 mm (26 AWG) for runs up to 500 meters (1640 ft.).

Your Martin dealer can supply the right cable in various lengths.

CONNECTIONS

The XLR data sockets are wired pin 1 to ground, pin 2 to signal - (cold), and pin 3 to signal + (hot). This is the standard pin assignment for DMX devices.

One or more adaptor cables may be required to connect the MiniMAC Maestro to the controller and other lights if they have 5-pin connectors or reversed signal polarity on pins 2 and 3.

5-pin to 3-pin Adaptor	
Male	Female
1	1
2	2
3	3
4	
5	
P/N 11820005	

3-pin to 5-pin Adaptor	
Male	Female
1	1
2	2
3	3
	4
	5
P/N 11820004	

3-pin to 3-pin Phase-Reversing Adaptor	
Male	Female
1	1
2	3
3	2
P/N 11820006	

To connect for controller operation

- 1 Connect a data cable to the controller's data output. If controller has a 5-pin output, use a 5-pin male to 3-pin female adaptor cable (P/N 11820005). Lead the cable from the controller to the first fixture and plug it into the data input.
- 2 Connect the output of the fixture closest to the controller to the input of the next fixture. If connecting to a fixture with reversed-polarity (pin 3 cold), insert a phase-reversing cable between the two fixtures.
- 3 Continue connecting fixtures output to input. Up to 32 devices may be connected on a serial link.
- 4 Terminate the link by inserting a male termination plug (P/N 91613017) into the data output of the last fixture. A termination plug is simply an XLR connector with a 120 ohm, 0.25 W resistor soldered across pins 2 and 3.

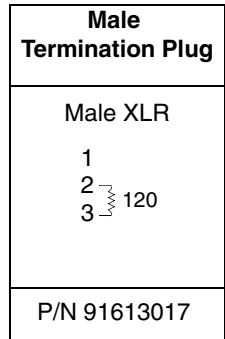

MODE SELECTION

The MiniMAC Maestro has 4 control modes for operation with DMX512 controllers. The modes mix tracking and vector control with 8 and 16-bit gobo, pan, and tilt position control in different combinations. Mode 1 provides basic control and requires the fewest channels. Mode 4 provides the full set of control options.

Mode	Control	Resolution	Channels
D1	Tracking	8-bit	6
D2	Tracking	16-bit	9
D3	Tracking/Vector	8-bit	8
D4	Tracking/Vector	16-bit	11

Table 3: DMX mode summary

TRACKING VERSUS VECTOR CONTROL

With tracking control (all modes) the speed at which an effect changes from one position to another (fades) is determined by programming a fade time between 2 scenes using a cross-fader.

With vector control (modes 3 and 4), speed is programmed on separate speed channels. This provides a way to program fades on controllers without cross-faders. With some controllers, vector control provides smoother movement than tracking control, particularly at slow speeds.

The speed channel must be set to “tracking speed” when using a cross-fader (tracking control) to program fades.

The speed channels also provide a “blackout speed” that makes transitions invisible.

8-BIT VERSUS 16-BIT PAN/TILT RESOLUTION

The 8-bit modes (1 and 3) provides coarser control of pan, tilt, and gobo indexing than the 16-bit modes (2 and 4), which use 3 additional control channels for fine position control.

To select DMX mode

- 1 Scroll to `Pro` in the main menu, press [enter], and scroll to the desired DMX mode, `d1`, `d2`, `d3`, or `d4`.
- 2 Press [enter] to activate the setting and return to the main menu.

ADDRESS SELECTION

The control address, also known as the start channel, is the first channel used to receive instructions from the controller. The total number of channels used depends on the control mode.

Be sure to allow adequate channels when setting the control address. If control channels for one fixture overlap control channels for another fixture, then one of the fixtures will receive the wrong commands. Two MiniMAC Maestros operating in the same control mode may share the same address if they are to respond identically. They will receive the same commands and individual control will be impossible.

To set the control address

- 1 Scroll to `Adr` in the main menu and press [enter]. The current address is displayed.
- 2 Scroll to the address that is assigned to the fixture on the controller. Press [enter] to activate the address setting.

CONTROLLABLE EFFECTS

LAMP POWER

Lamp power can be switched on and off from the controller. *When set-up for controller operation, and with the automatic lamp-on personality set to off, the lamp remains off until a lamp-on command is sent.*

Note: A peak of electric current many times the operating current is drawn briefly when striking a lamp. Striking many discharge lamps at once may cause a voltage drop that prevents lamps from striking or trips circuit breakers. When striking multiple fixtures, space lamp-on commands at 5 second intervals.

The lamp must be allowed to cool for several minutes after turning it off before it can be turned back on. To prevent accidental lamp-off commands, this command can be partially disabled from the control panel: see page 19. If a hot lamp does not strike, send the lamp off command and wait several minutes before trying again.

RESET

All effects can be reset to their index positions from the controller. To prevent accidental resets, the command can be partially disabled from the control panel: see page 19.

SHUTTER

The mechanical shutter opens, closes, and strobes at variable and random rates. The shutter closes automatically after 10 seconds if the light beam is projected on the base to prevent heat damage. The shutter opens instantly when the beam is moved.

FOCUS

The focus lens allows focussing from approximately 1 meter to infinity.

GOBOS

The MiniMAC Maestro provides 4 rotating gobo positions. Each position can be indexed with 8-bit or 16-bit resolution or continuously rotated at variable speeds.

PAN AND TILT

The head pans 540° and tilts 270°. If knocked or jarred out of position, the pan position automatically resets if the arm reaches the right limit and the tilt position automatically resets if the arm reaches the bottom limit. In some cases, the limit can be reached by setting the pan or tilt value to 255. Otherwise, the fixture can be reset as described above.

STAND-ALONE OPERATION

In stand-alone mode, individual MiniMAC Maestros can be programmed with up to 20 scenes without an external controller. Multiple MiniMAC Maestros can be linked together and scenes on all fixtures can be synchronously triggered by a “master” fixture.

CONTROL MODES

The MiniMAC Maestro provides two stand-alone modes that allow you to program and execute a sequence of up to 20 scenes without an external controller. The major differences between the two modes are shown in Table 4.

	DMX Stand-Alone Mode	IR Remote Control Mode
Maximum fixtures	32	10
Protocol setting	d4	rCS (master), rCr (others)
Link termination	yes	no
Execution	automatic, control panel, and MC-X	IR remote, control panel

Table 4: Stand-alone mode comparison

In **DMX Stand-Alone Mode**, up to 32 MiniMAC Maestros may be connected for synchronized operation triggered by a “master” fixture. Execution may be set to start automatically upon startup, selected from the control panel, or toggled on/off with an MC-X controller, which also provides direct selection of 7 scenes. Programming is done from each fixture’s control panel. Fixtures may be programmed in IR Mode and then operated in DMX Stand-Alone Mode if stand-alone operation of more than 10 fixtures is required.

The **Infrared Remote Control (IR) Mode** supports up to 10 fixtures and requires the infrared transmitter and receiver listed on page 51. (One receiver supports up to 10 fixtures.) Programming and execution is done from the handheld remote control or the fixture control panels.

When working with multiple fixtures in either mode, each fixture is individually programmed with its own scenes, and then during playback, scenes of the same

number on each fixture can all be triggered to start simultaneously by a master fixture. This is further explained in the section “About scene timing” on page 29.

FIXTURE SETUP

Important: *The IR mode address is different from the DMX mode address and can only be set after rCS or rCr has been selected.*

To setup multiple fixtures for DMX Stand-Alone operation

- 1 Plug a data cable into the OUT socket of the first fixture and the IN socket of the next fixture. Repeat as required to connect up to 32 fixtures.
- 2 Insert a male termination plug (P/N 91613017) into the OUT socket of the last fixture. If you experience random “flicker” or other unexplained control problems, insert a female termination plug (P/N 91613018) into the IN socket of the first fixture.
- 3 Set all fixtures to DMX mode 4. From the control panel, scroll to `PrO` in the main menu, press [enter]. Select `d4`. Press [enter] to activate the setting. Address setting is not required.
- 4 Using the run options under the control menu set the execution settings of the respective fixtures to run as slaves, or as the master (only one fixture on the link may be the master). See “Execution commands” on page 32.
- 5 (Optional) Set the personality options described on page 19.
- 6 Study “About scene timing” on page 29, ensuring that you understand it and then use the menus to program scenes into each fixture. See “Menu commands” on page 30.

To setup one fixture for IR Stand-Alone operation

- 1 Insert the receiver module into the serial data In socket. Position the sensor arm as desired but avoid turning it more than necessary.
- 2 Scroll to `PrO` in the control panel main menu, press [enter], and scroll to `rCS`. Press [enter].
- 3 Select `Adr` from the main menu and press [enter]. Select an address from 0 to 9 and press [enter].
- 4 Stand 2 meters (6 ft.) away from the fixture, point the remote control at the receiver, and press the lamp power button. If there is no response, try the ID button. If there is still no response, reverse the sensor head by rotating the sensor arm 180° and folding it over.
- 5 (Optional) Set the gobo blackout, display, and automatic lamp-on personality options as described on page 19.

- 6 Study “About scene timing” on page 29, ensuring that you understand it and then use the remote control to program scenes into the fixture. See “Remote control commands” on page 32.

To setup multiple fixtures for IR Stand-Alone operation

Important! *Do not terminate the link in IR Mode.*

Note *Some early versions of the MiniMAC Maestro receiver module have the restriction that they only support IR operation for a single fixture. These modules can be easily identified as they are black. The newer version that supports multiple fixtures is grey.*

- 1 Select a fixture to be the master. For convenience, select an end fixture close to a good programming spot. Insert the receiver module into the master's serial data In socket. Position the sensor arm as desired but avoid turning it more than necessary.
- 2 From the control panel of the master fixture, scroll to `P r o` in the main menu, press [enter], and scroll to `r C S` (remote control, send). Press [enter] to activate the setting. Select `A d r` from the main menu and press [enter]. Select an address from 0 to 9 and press [enter].
- 3 Stand 2 meters (6 ft.) away from the fixture, point the remote control at the receiver, and press the lamp power button. If there is no response, try the ID button. If there is still no response, reverse the sensor head by rotating the sensor arm 180° and folding it over.
- 4 Plug a data cable into the OUT socket of the master fixture and the IN socket of the next fixture. Repeat as required to connect up to 10 fixtures. **DO NOT** place a termination plug in the output of the last fixture.
- 5 On each fixture except the master, scroll to `P r o` in the main menu, press [enter], and scroll to `r C r` (remote control, receive). Press [enter] to activate the setting. Select `A d r` from the main menu and press [enter]. Select an unused address from 0 to 9 and press [enter]. (Each fixture must have a unique address: they may share an address, though, if you always want them to behave identically.)
- 6 (Optional) Set the gobo blackout, display, and automatic lamp-on personality options as described on page 19.
- 7 Study “About scene timing” on page 29, ensuring that you understand it and then use the remote control to program scenes into each fixture. See “Remote control commands” on page 32.

ABOUT SCENE TIMING

Each scene has a dynamic part - the fade - during which effects move to the scene's programmed positions, and a static part - the wait - where effects do not change.

The duration of the fade and wait is programmed individually for each scene. The fade time may be 0 - 120 seconds; the wait time may be 0 - 600 seconds. The total time it takes a scene to execute is the sum of the fade and wait times.

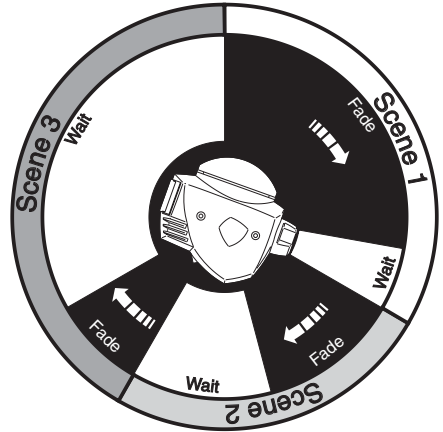

When operating multiple fixtures, the wait time is determined by a master fixture. Each fixture fades and waits at its own rate and then remains in the "wait state" until receiving a start scene *xx* command from the master fixture.

When programming in Master/Slave situations, keep in mind the following:

- Every fixture can have up to 20 on-board scenes with individual fade & wait times.
- Scenes are numbered from 0 to 19.
- A scene contains a fade-section, followed by a wait-section.
- When running "synchronous triggering" the master issues commands to the slave fixtures to "go to scene *xx*", where *xx* is the scene number that master will execute next.
- If a slave has fewer scenes than the master directs it to run, it will derive which scene to go to by dividing the number of the scene it has been commanded to go to (scene 5, for example) by the total number of scenes that the slave fixture has (4, for example) in whole numbers (no decimal places). In this example 5 divided by 4 results in 1, with 1 remainder. This remainder will be the number of the scene that the slave fixture starts - scene 1. Generally though, when a Slave fixture reaches its own last scene before the Master fixture, a "go to scene *x*" message will result in the first scene being played.
- If a slave has more scenes than the master calls, the last scenes in the slave will never be executed.
- A slave fixture will not listen for the next message from the master fixture before it has finished its current scene. This may result in skipping a slave scene if slave has a longer scene time than master. Note that in the following example that the Slave

synchronizes its scenes with the Master, and also note that scene S4 that is programmed in the Slave fixture will not run.

F=fade, W=wait Timeline =>

	M0	M1	M2	M3	
Programmed in Master	F W	F W	F W	F W	
	S0	S1	S2	S3	S4
Programmed in Slave	F W	F W	F W	F W	F W
Result	M0	M1	M2	M3	
	F W	F W	F W	F W	
	S0	S1	S2	S3	
	F W	F W	F W	-- --	F W

- The scene times in the Master fixture should be equal to or longer than the corresponding scene times of the other fixtures. You may get undesirable results if, for example, a scene is programmed in the master to last 10 seconds and in other fixtures to fade for 15 seconds. Note that in the following example the scenes in the Slave run out of their programmed sequence because scenes 0 and 2 on the Slave are longer than the corresponding scenes on the Master.

M=master, S=slave

F=fade, W=wait

Time >

	M0	M1	M2		
Programmed	F W	F W	F W		
Master	F W	F W	F W		
	S0	S1	S2		
Slave	F W	F W	F W		
Result	M0	M1	M2	M0	M1
Master	F W	F W	F W	F W	F W
	S0		S2		S1
Slave	F W		F W	F W
			

MENU COMMANDS

The menu commands can be used to program and execute scenes in both DMX Stand-Alone Mode and IR Remote Control Mode.

Note

Control panel actions sometimes result in a information being written to the fixture's memory. If the fixture is powered off during this process updates may be lost. A "Memory not yet stored" warning indicator appear as a red dot in the left side of the control panel display during memory update. Do not power the fixture off while this is lit.

SCENE COMMANDS

Store scene (SCE / STO): Save settings in the current scene.

Add scene (SCE / AdD): Save settings in a new scene at the end of the sequence.

Insert scene (SCE / InS): Save settings in a new scene before the current scene, which moves up a number. *Tip: Think of the Add and Insert commands as Save commands, to be used as the last step after programming all effects.*

Delete scene (SCE / dEL): Remove the current scene from memory. Scenes above the deleted scene move down a number.

Next scene (SCE / nE): Step to the next scene.

Previous scene (SCE / PrE): Step to the previous scene.

Clear scenes (SCE / CLr): Remove all scenes from the fixture memory.

EFFECTS COMMANDS

Lamp on (LOn): Apply power to the lamp. In DMX Stand-Alone Mode, this command must be programmed in at least one scene if the automatic lamp on feature is disabled.

Lamp off (LOF): Turn off the lamp. *A hot lamp must cool for several minutes before it will strike again.*

Shutter control (SHU): Open, close, and flash the shutter at different speeds. (See Table 2.)

Focus adjustment (FOC): Set focus position.

Indexed gobo selection (gob / ind): Select a gobo for projection at a fixed angle.

Rotating gobo selection (gob / rot): Select a gobo for projection with continuous rotation.

Gobo index (rgo / CrS, Fin): Set gobo angle. (Applies only when an indexed gobo is selected.) Select CrS first, set the rough angle, and then fine-tune with Fin. (See Table 2.)

Gobo rotation (rgo): Set speed and direction of continuous rotation. (Applies only when a rotating gobo is selected.)

Pan position (PAN / CrS, Fin): Set pan angle. Select CrS first, set the rough angle, and then fine-tune if desired with Fin.

Tilt position (tIL / CrS, Fin): Set tilt angle. Select CrS first, set the rough angle, and then fine-tune if desired with Fin.

TIMING COMMANDS

Scene wait time (UUA): Set the scene wait time in seconds.

Scene fade time (FAd): Set the scene fade time in seconds.

EXECUTION COMMANDS

Important! *The execution setting automatically resumes on startup.*

Off (`run / OFF`): Stop stand-alone execution.

Run single fixture (`run / Sin`): Start stand-alone operation of a single fixture.

Run master fixture (`run / Snd`): Select the master fixture and start stand-alone operation.

Run synchronized fixture (`run / SYn`): Select a non-master (synchronized) fixture and start stand-alone operation.

MC-X EXECUTION

To execute stand-alone scenes with an MC-X Controller

- 1 Connect the MC-X controller to the MiniMAC Maestro's data input. If multiple MiniMAC Maestros are connected, plug the controller into the first fixture in the link.
- 2 On each fixture, select `Ctrl / run / OFF` and press [enter]. Press [menu] to exit the `Ctrl` menu. Set each fixture to DMX mode 4.
- 3 To trigger scenes 00-06, press the numbered preset buttons on the MC-X.
- 4 To have each fixture run its own routine, press [Auto].

REMOTE CONTROL COMMANDS

Important! *Fixtures blink to acknowledge commands from the remote control.*

FIXTURE SELECTION

Each fixture must be assigned an address from 0 - 9 during setup so that it can be individually controlled with the remote control. To select a fixture, press ID and enter its address using the number keys. Multiple fixtures may be selected by entering more than one address. For example, pressing [ID] [1] [2] [3] selects fixtures 1, 2, and 3.

LAMP POWER

The lamp power button toggles lamp power on and off on selected fixtures. The button must be held for 5 seconds to turn lamp power off. Note: Lamps cannot be

turned off during scene execution and a discharge lamp must cool for several minutes after being turned off before it can be turned back on.

SCENE TIMING

Fade and wait times are set by pressing the scene timing buttons and entering the desired time in seconds using the number keys.

SCENE SELECTION

Scenes are created, selected, saved, and deleted using the six scene keys. The current scene is displayed on the fixture display after the letter “r” during editing and after the letter “P” during execution.

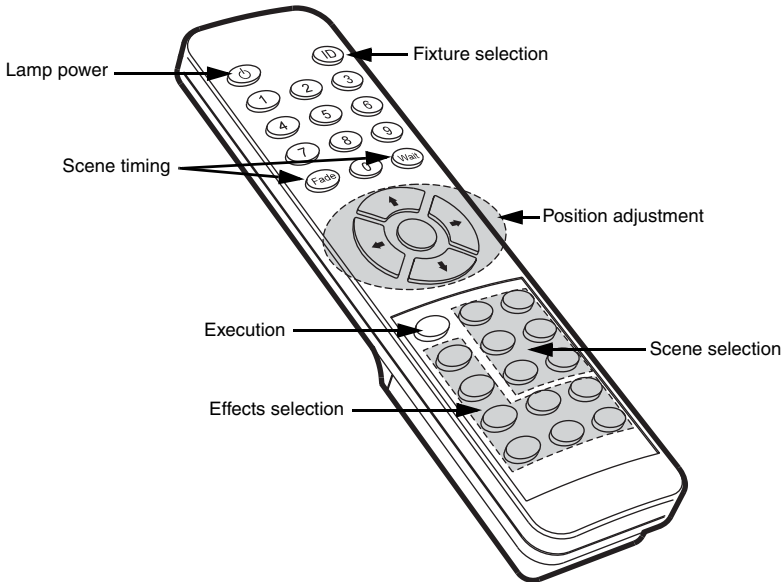

- Prev (previous scene) scrolls backwards through scenes on selected fixtures. The fixture blinks three times when the first scene is reached.
- Next (next scene) scrolls forwards through scenes on selected fixtures. The fixture blinks three times when the last scene is reached.
- Store (store scene) saves effect and timing settings to the current scene. Fixtures confirm the command by blinking twice.
- Delete (delete scene) removes the current scene from memory. Scenes above the deleted scene are renumbered. Fixtures confirm the command by blinking twice.
- INS (insert scene) creates and saves a new scene before the current scene, which moves up a number. Fixtures confirm the command by blinking twice. If a fixture blinks three times, its memory is full.
- ADD (add scene) creates a new scene at the end of the sequence with the settings that are active when the scene is created. Fixtures confirm the command by blinking twice. If a fixture responds by blinking three times, its memory is full.

00 01 02

Store saves settings in the current scene.

00 01 02 03

Add saves settings in a new scene at the end of the sequence.

00 01 02 03

Insert saves settings in a new scene before the current scene.

EFFECTS ADJUSTMENT

The look of a scene is programmed by first selecting an option with the effect selection buttons and then adjusting the option with the position adjustment buttons. When two effects - pan and tilt for example - are assigned to a selection button, the up/down arrows control one effect and the left/right arrows control the other effect. If there is only one effect, the up/down arrows usually provide course adjustment and the left/right arrows usually provide fine adjustment. The middle button returns effects to a default position.

Some effects do not apply. The fixture acknowledges valid effect selections by blinking once.

EXECUTION

The Run/Stop button toggles scene execution on/off on selected fixtures. Scenes execute in a continuous ascending loop.

All remote control functions except Run/Stop are disabled during execution.

The Store Remote Status personality option, which is active by default (see “Control panel” on page 14), links the Run/Stop action on the IR remote to the execution settings for stand-alone operation. This means that when you select run or stop via the remote control this will update the fixture’s execution settings. This enables you to – via the IR remote - switch on or off the automatic starting of stand-alone operation when the fixture is powered on.

PROGRAMMING EXAMPLE

In the following example, three MiniMAC Maestros are programmed in IR Stand-Alone Mode to project gobos that chase each other counterclockwise in a triangular pattern.

SETUP

Setup three fixtures in a row and point them toward a wall. Insert the IR receiver in the fixture on the right end as seen facing the wall from behind the fixtures. This will be the master fixture; set it to `rCS` mode and give it address 1.

Insert a data cable into the output of fixture 1 and connect it to the input of the middle fixture. Set the middle fixture to `rCr` and give it address 2. Insert a data cable into the output of fixture 2 and connect it to the input of the third fixture. Set the third fixture to `rCr` and give it address 3.

From the control panel of each fixture, select `Ctr / SCE / CLr` and press [enter] to delete all programming. Press [menu] a few times until the display reads `r00`.

Point the remote control at the IR receiver and press the lamp power button.

SCENE 00

Press [ID] [1] to select fixture 1. Press [Pan/Tilt] and position the beam at the bottom-right corner of the triangle. Press [Color/Gobo] and select a gobo with [up] and [down]. Press [Effect/Focus] and focus with [up] and [down]. (Fine focus is available with [left] and [right].) Press [Rotating/Index] and rotate the gobo to the desired angle with [left] and [right]. Press [fade] [10] [wait] [5] to set a fade time of 10 seconds and a wait time of 5 seconds. Press [Store] to save the settings to scene 00.

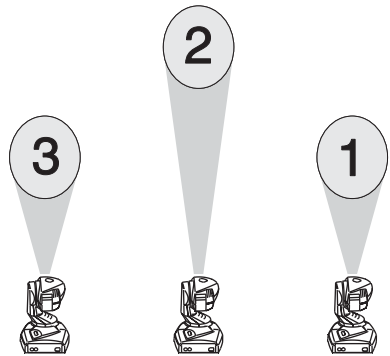

Press [ID] [2] and similarly set fixture 2 to project a gobo at the top of the triangle. Set a fade time of 6 seconds and set the wait time to 4. Press [Store].

Select fixture 3 and focus a gobo at the bottom-left corner of the triangle. Set a fade time of 7 seconds and set the wait time to 4. Press [Store].

SCENE 01

Press [ID] [1] to select fixture 1. Press [Pan/Tilt] and position the beam over fixture 2's beam at the top of the triangle. Press [Effect/Focus] and focus with [up] and [down]. Press [Rotating/Index] and set the angle with [left] and [right]. Press [Add] to create and save the second scene with the same fade and wait times as the first scene.

Press [ID] [2] and similarly set fixture 2 to project over fixture 3 at the bottom-left corner. Press [Add].

To use the same placement trick with fixture 3, first select fixture 1 and press [Prev] to view scene r00. Then select and program fixture 3. Press [Add].

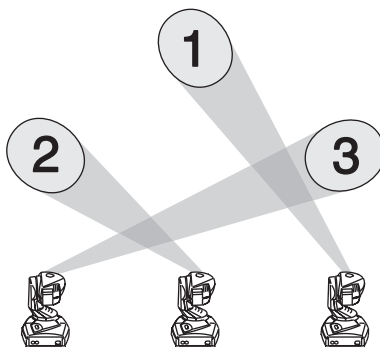

SCENE 02

Select fixture 1 and focus the gobo in the bottom-left corner. Press [Add]. Select fixture 2 and focus the gobo in the bottom-right corner. Press [Add]. Press [Prev] [Prev] to scroll fixture 2 back to scene r00 at the top of the triangle. Focus fixture 3 at the top of the triangle and press [Add].

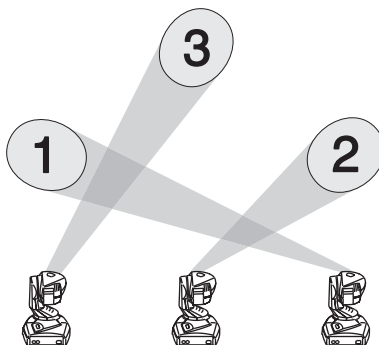

EXECUTION

To run the sequence, press [ID] [1] [2] [3] [Run/Stop]. During execution the “r” in the display changes to a “P” on the master fixture and to an “S” on the other fixtures.

LAMP

COMPATIBLE LAMPS

The MiniMAC Maestro is designed to use the Philips CDM-SA/T 150W discharge lamp. *Installing any other lamp may damage the fixture.*

Lamp	Efficiency	Color Temp.	Average Life
Philips CDM-SA/T 150W	85 Lm/W	4000 K	6000 hr.

Table 5: Lamp specifications

To replace the lamp

WARNING! *Wear safety glasses and allow the lamp to cool for at least 5 minutes before opening the head.*

- 1 Disconnect the fixture from power and allow it to cool.
- 2 Pull open the rear cover.

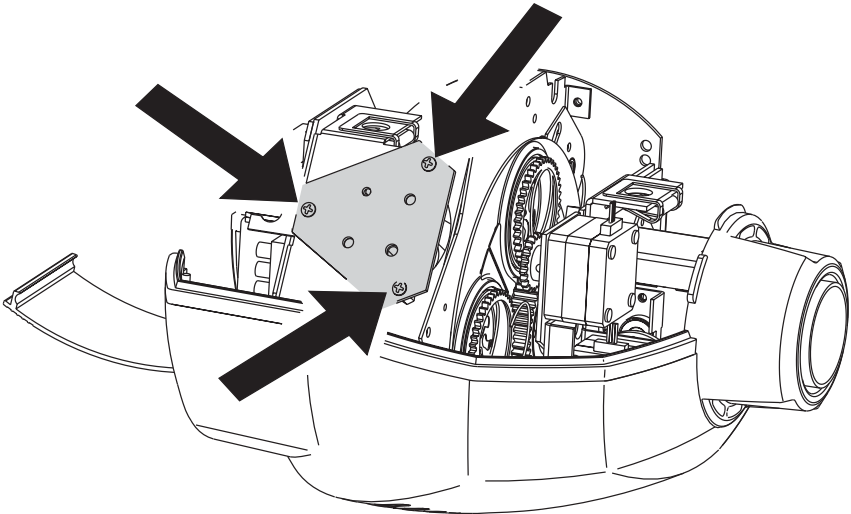

- 3 Remove the 3 screws in the corners of the lamp base plate and remove the lamp socket assembly.

- 4 Remove the old lamp from the socket.
- 5 Holding the new lamp by its ceramic base (do not touch the glass), insert the lamp squarely into the socket.

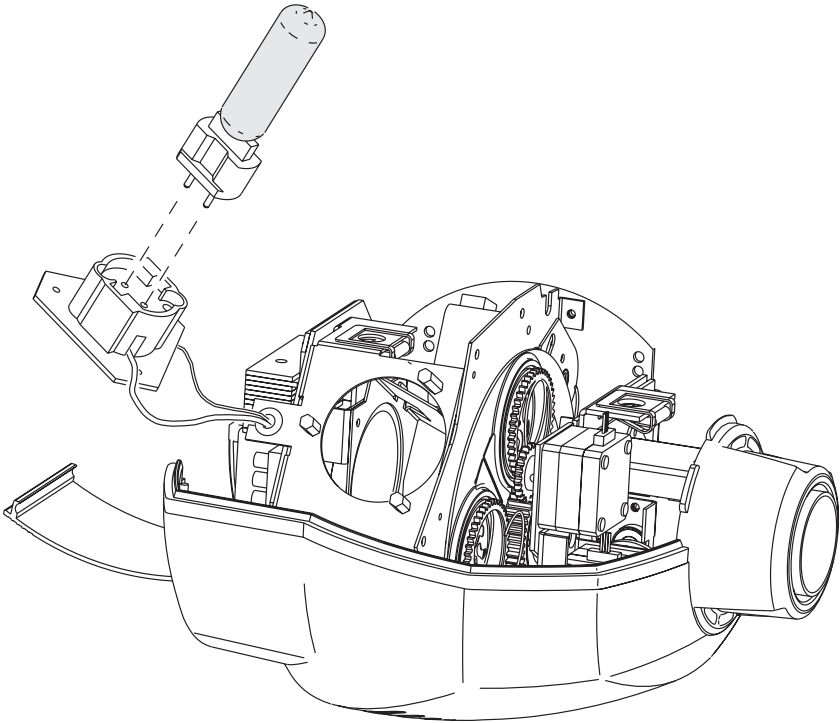

- 6 Clean the glass bulb with a clean, lint-free cloth wetted with alcohol.
- 7 Insert the lamp assembly and replace the screws. Replace the top cover and close the rear cover before applying power.
- 8 Reset the lamp hour and lamp strike counters as described on page 20.

GOBOS

The MiniMAC Maestro holds up to four size-E gobos. For correct projection, install gobos with the true side of the image facing the lamp.

CUSTOM GOBOS

The MiniMAC Maestro accepts glass, steel, and aluminum gobos with the following dimensions (size-E). For best performance, the image should be true on the coated side of glass gobos.

- Outside gobo diameter: 37.5 +0/-0.3 mm (1 15/32 +0/-0.01 in.)
- Maximum image diameter. 30 mm (1 3/16 in.)
- Maximum gobo thickness 3 mm (1/8 in.)

IMAGE SIZE

The focal length of the MiniMAC Maestro is 90 mm (3.54 in). To calculate the size of a projected image using a gobo of a given size, the formula is

$$\text{projected image size} = \frac{\text{gobo image size} \times \text{projected distance}}{\text{focal length}}$$

To calculate the gobo image size required to achieve a projected image size, the formula is

$$\text{gobo image size} = \frac{\text{projected size} \times \text{focal length}}{\text{projected distance}}$$

INSTALLATION

To install gobos

- 1 Turn off the lamp and allow it to cool for at least 5 minutes. Disconnect the fixture from power.
- 2 Unlock the head cover fasteners by turning them a quarter-turn counterclockwise. Open the rear cover and then lift off the head cover.
- 3 Turn the gobo wheel as required to access the desired position. Pull the gobo holder away from the wheel slightly to release. Remove the gobo holder.
- 4 Remove the gobo retention spring from the holder and drop out the old gobo. Insert the new gobo into the holder true-side-first.
- 5 Identify the narrow end of the retention spring by pressing it spring flat: the narrow end is on the inside.
- 6 Insert the spring with the narrow end against the gobo. Push the end of the spring in under the lip of the holder.
- 7 Work the rim of the gobo holder under both clips and snap the gobo holder back into position. If necessary, a small screwdriver or similar tool may be used to pry the clips open.
- 8 Replace and close the head covers before applying power.

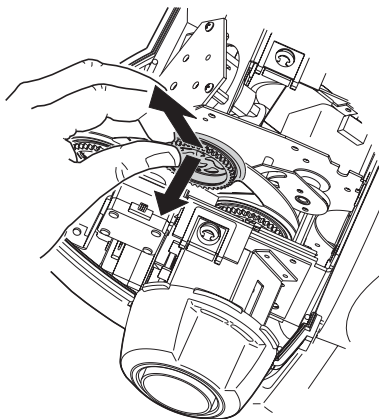

Flatten spring to find narrow end. Insert spring with narrow end against reversed side of gobo.

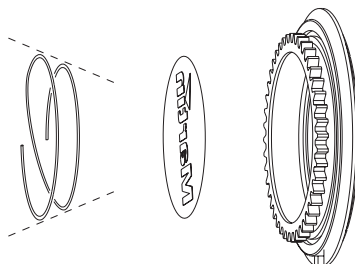

SUGGESTED SUPPLIERS

The following companies can supply quality custom gobos from your artwork.

Apollo Design Technology, Inc.

E-mail: sales@internetapollo.com
Internet: www.internetapollo.com
Telephone: +1 (219) 497-9191
Fax: +1 (219) 497-9192

Apollo Design Technology, Inc. manufactures stainless steel and glass gobos in custom or standard designs. BW SuperResolution and ColourScenic gobos feature 10,000 dpi resolution. Dichroic filters, textured dichroics, and crushed dichroics also available.



Beacon AB

E-mail: mail@beacon.nu
Internet: www.beacon.nu
Telephone: +46 (0) 90-715830
Fax: +46 (0) 90-710058

Beacon manufactures high quality full color and B/W customized glass gobos. The Beacon Gobo group is spread throughout the world from Australia to Argentina to ensure personal service with high quality and fast delivery.



DHA Lighting Ltd.

E-mail: custom.gobo@dhalighting.co.uk
Internet: www.dhalighting.co.uk
Telephone: +44 020-7771-2900
Fax: +44 020-7771-2944

DHA Lighting Ltd., experienced manufacturers and suppliers of custom gobos. Available in monochrome and coloured dichroic glass, or a variety of metals including stainless steel and aluminium. Predistortion of images a speciality. Over 900 standard gobo designs to choose from.



Rosco

E-mail: customgobo@rosco.com
Internet: www.rosco.com
Telephone: +44 (0) 208-659-2300 (Europe)
+1 (866) 228-2256 (USA)
Fax: +44 (0) 208-659-3153 (Europe)
+1 (512) 388-0196 (USA)

For more than two decades Rosco Laboratories has been the world's largest supplier of gobos and dichroic filters for the entertainment industries. You are serviced from fully staffed offices in seven countries around the world.



BASIC SERVICE

The MiniMAC Maestro requires simple routine maintenance. The schedule depends heavily on the operating environment; please consult a Martin service technician for recommendations.

Refer all service not described here to a qualified Martin technician.

Important! ***Excessive dust, grease, and smoke fluid buildup degrades performance and causes overheating and damage to the fixture that is not covered by the warranty.***

Warning! ***Disconnect the fixture from power before removing any cover.***

CLEANING

To open the head

- 1 Disconnect the fixture from power and allow it to cool. Unlock the head cover fasteners by turning them a quarter-turn counterclockwise. Open the rear cover by pulling from the ribbed end.
- 2 Pull off the top head cover.
- 3 When replacing the cover, turn the fasteners a half to a quarter turn clockwise until they click. *Do not overtighten.*

To clean optical components

Use care when cleaning optical components. The surfaces are fragile and small scratches may be visible.

- 1 Disconnect the fixture from power and allow it to cool. Remove the head cover.
- 2 Blow or vacuum away loose dust. Remove residues from lenses with a soft cloth or cotton swabs wetted with isopropyl alcohol. Regular glass cleaner may also be used, but no residues may remain.
- 3 Rinse with distilled water. Mixing the water with a small amount of wetting agent such as Kodak Photoflo will help prevent streaking and spotting.
- 4 Dry with a clean, soft and lint-free cloth or blow dry with compressed air.

To clean the fan and air vents

Important! *Neglecting to clean the fans and air vents can result in damage to the fixture that is not covered by the warranty. Dust, smoke, and grease buildup reduce the cooling air flow and will cause the fixture to overheat. When the fixture overheats, a thermo switch cuts power to the lamp until the fixture cools, and the lamp cycles on and off at regular intervals.*

To maintain sufficient cooling and air flow, inspect the air vents and fans at least every 3 months or 1000 hours of operation and clean the fan and air vents by removing dust and dirt from the fans and vent grills using a soft brush, cotton swab, vacuum, or compressed air.

INSTALLING SOFTWARE

Firmware updates are released when features are added. The latest version is available from the Support Area of the Martin Professional web site at <http://www.martin.dk>. Firmware is installed using a Martin MP-2 uploader.

Important! *Fixtures must be in a DMX mode and the data link must be terminated.*

To install software, normal method

- 1 Download the latest control software from the Martin Professional web site at <http://www.martin.dk>. Install the software in a Martin MP-2 uploader.
- 2 Connect the uploader to the fixture as you would a controller. Apply power to the uploader and the fixtures.
- 3 After the fixture has finished resetting, initiate the software upload as described in the uploader manual. Wait.
- 4 When the upload is successfully completed, the fixture displays the new version number and resets. Disconnect the upload device.
- 5 If a check-sum error (CSE) occurs and/or the fixture does not reset, data was interrupted or corrupted during transmission. Reattempt the upload using backup method I, or try this procedure again.

To install software, backup method I

Follow this procedure exactly as described to install software if a normal upload attempt is unsuccessful and a check-sum error (CSE) occurs.

- 1 Disconnect the fixture from power: it must be off at least 10 seconds. *Do not apply power to the fixture until the uploader is connected and ready.*

- 2 Connect the MP-2 uploader to the fixture as you would a controller. *Terminate the link.*
- 3 Prepare the uploader for a boot mode upload but do not initiate the upload.
- 4 Apply power to the fixture. The control panel displays CSE, then bSL, then b. When b is displayed, *wait 5 seconds* and then initiate the software upload from the uploader. Wait.
- 5 When the upload is successfully completed, the fixture displays the new version number and resets. Disconnect the upload device.

To install software, backup method II

Use this procedure to install software only if all else fails.

- 1 Disconnect the fixture from the data link and power.
- 2 Use tweezers to move the jumper on the main circuit board to the boot setting.
- 3 Prepare the MP-2 uploader for a boot mode upload but do not initiate the upload.



normal setting

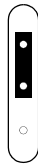

boot setting

- 4 Connect the MP-2 uploader to the fixture as you would a controller. *Terminate the link.*
- 5 Apply power to the fixture and wait 5 seconds. Initiate the software upload from the uploader. Wait.
- 6 When the upload is successfully completed, the fixture displays the new version number and resets. Disconnect the MP-2 upload device. Disconnect the fixture from power and move the jumper back to the normal setting.

REPLACING FUSES

Warning! *Never replace fuses with ones of a different rating!*

To replace the main fuse

- 1 Unplug the mains cable from the input socket. Pry open the fuse holder and remove the fuse.
- 2 Replace the fuse with one of the same type. The fuse rating is listed on serial number label and in the specifications.

To replace secondary fuses

- 1 Disconnect the fixture from power.
- 2 Remove the 4 base cover bolts. Move the cover without disconnecting wires.
- 3 Pry out the defective fuse and replace it with one of the same rating.
- 4 Replace the cover before applying power.

INSERTING OR CHANGING A COLOR FILTER

The MiniMAC Maestro has a spring clip in front of the gobo wheel that can accept a fixed color filter. There is not much room to insert or remove the filter and this procedure must be performed by an authorized Martin dealer. A list of available filters can be found in “Dichroic color filters” on page 51.

TROUBLESHOOTING

10

Problem	Probable cause(s)	Remedy
No response from fixture when power is applied.	No power to fixture.	Check power cables.
	Primary fuse blown.	Replace fuse.
	Secondary fuse blown.	Replace fuse.
No response to IR remote control.	Remote control not pointed at receiver or signal is blocked.	Point remote directly at receiver from an unobstructed position.
	Backwards IR receiver.	Flip and turn receiver arm.
	No signal from remote.	Replace batteries in remote.
	Commands ignored during execution.	Stop scene execution.
	Fixture connected to a data link that is using a DMX protocol. This jams the IR signal.	Remove the fixture from the link.
	Improper setup.	Verify protocol (rCr or rCS) and address settings.
Fixture resets but does not respond correctly to controller (DMX mode operation).	Controller not connected.	Connect controller.
	Incorrect addressing of the fixtures.	Check address and mode settings on fixture and controller.
	Controller pin-out does not match fixture pin-out (signal reversed).	Insert a swapper cable in data input.
	Stand-alone mode enabled.	Verify that DMX address is displayed at top of menu. If not, disable stand-alone mode.
	Bad data link connection.	Inspect cables and correct poor connections and/or broken cables.
	Data link not terminated.	Insert termination plug in output of last fixture.
	Defective fixture or 2 devices transmitting on link.	Bypass fixtures one at a time until normal operation is regained: unplug both connectors and connect them directly together.
	Fixture does not reset.	An effect requires adjustment.

Problem	Probable cause(s)	Remedy
No light.	Lamp missing or blown.	Disconnect fixture and replace lamp.
	Shutter may be closed.	Open the shutter.
Lamp cuts out intermittently or burns out too quickly.	Fixture is too hot.	Allow fixture to cool.
	Incorrect power supply setting.	Check setting.
	Fans or air vents may be blocked.	Clear/clean air vents and fan.
S t E (memory error) message displayed	The user settings cannot be read from memory.	Contact service technician.
P A E (pan error time-out) message displayed	Pan reset switch malfunction.	Contact service technician.
T I E (tilt error time-out) message displayed	Tilt reset switch malfunction.	Contact service technician.
C S E (check-sum error) message displayed	Unsuccessful software upload.	See "Installing software".
Shaky movement during combined pan/tilt movement	Movement occurs at a resonant velocity.	Make small adjustment to fade path or fade time.
	Controller has poor DMX tracking.	Use the speed channel and avoid controller fading.

DMX PROTOCOL



1	2	3	4	Value	Percent	Function
1				0 - 19	0 - 7	Shutter, Strobe, Reset, Lamp On/Off Shutter closed
				20 - 49	7 - 19	Shutter open
				50 - 112	19 - 44	Strobe, fast to slow
				113 - 127	44 - 50	Shutter open
				128 - 137	50 - 53	Random strobe, fast
				138 - 147	54 - 57	Random strobe, medium
				148 - 157	58 - 61	Random strobe, slow
				158 - 207	62 - 81	Shutter open
				208 - 217	81 - 85	*Reset
				218 - 227	85 - 87	Shutter open
				228 - 237	89 - 93	Lamp on
				238 - 247	93 - 97	Shutter open
				248 - 255	97 - 100	*Lamp off: hold for 5 seconds
2				0 - 19	0 - 7	Image Selection Image 1, indexed rotation
				20 - 39	7 - 15	Image 2, indexed rotation
				40 - 59	15 - 23	Image 3, indexed rotation
				60 - 79	23 - 31	Image 4, indexed rotation
				80 - 99	31 - 39	Image 1, continuous rotation
				100 - 119	39 - 46	Image 2, continuous rotation
				120 - 139	47 - 54	Image 3, continuous rotation
				140 - 159	55 - 62	Image 4, continuous rotation
				160 - 198	63 - 78	Clockwise wheel rotation, slow to fast
			199 - 255	78 - 100	Counterclockwise rotation, fast to slow	
3				0 - 255	0 - 100	Image Rotation (select image on ch. 3) Coarse position index (MSB), Min → Max
				0 - 2	0	Rotation velocity No rotation
				3 - 127	1 - 50	CW rotation, slow to fast
				128 - 252	50 - 99	CCW rotation, fast to slow
				253 - 255	99 - 100	No rotation
-	4	-	4	0 - 255	0 - 100	Image Rotation, Fine Position Fine position index (LSB), Min → Max
4	5	4	5	0 - 255	0 - 100	Focus Infinity → near

** If disabled, confirm with image 4 and close focus.*

1	2	3	4	Value	Percent	Function
5	6	5	6	0 - 255	0-100	Pan Left to right (128 = neutral)
-	7	-	7	0 - 255	0-100	Pan fine (LSB) Left to right
6	8	6	8	0 - 255	0-100	Tilt Up to down (128 = neutral)
-	9	-	9	0 - 255	0-100	Tilt fine (LSB) Up to down
-	-	7	10	0 - 2 3 - 245 246 - 248 249 - 251 252 - 255	0 1 - 96 96 - 97 98 99 - 100	Pan/Tilt Speed Tracking mode Fast to slow Tracking, P t S = S L O Tracking, P t S = F S t Blackout while moving
-	-	8	11	0 - 2 3 - 251 252 - 255	0 1 - 96 97 - 100	Image and Focus Speed Tracking mode Fast to slow Blackout while moving

SPECIFICATIONS



PHYSICAL

Length: 390 mm (15.4 in)
Width: 316 mm (12.4 in)
Height: 415 mm (16.3 in)
Weight: 14.0 kg (30.8 lbs)

SOURCE

Philips CDM “Master Color” 150 W (included) 85 Lm/W, 6000 hr., 4000 K

OPTICS

Focused beam angle: 19°
Focal length: 90 mm
Focus range: 1 m (3.2 ft.) to infinity

DATA COMMUNICATION

Hardware standard: RS-485
Data I/O: locking 3-pin XLR, pin 1 shield, pin 2 cold (-), pin 3 hot (+)
Recommended cable: 24 AWG (min.), low capacitance, 85-150 Ω shielded twisted pair

INSTALLATION

Mounting points: 1 pair of 1/4-turn locks
Orientation: any
Minimum distance to combustible materials: 0.3 m (12 in)
Minimum distance to illuminated surfaces: 0.3 m (12 in)
Minimum clearance around fan and air vents: 0.1 m (4 in)

THERMAL

Maximum ambient temperature (Ta): 40° C (104° F)
Maximum surface temperature: 55° C (131° F)

AC SUPPLY

AC input: 3-pin IEC male socket
Power supply options: 100/120/210/230/250 V, 50/60 Hz (switch-selectable)

MAXIMUM POWER AND CURRENT

100 V, 50 or 60 Hz: 260 W, 3.0 A
120 V, 50 or 60 Hz: 265 W, 2.5 A
210 V, 50 or 60 Hz: 245 W, 1.4 A
230 V, 50 or 60 Hz: 250 W, 1.2 A
250 V, 50 or 60 Hz: 255 W, 1.1 A

FUSES

Primary fuse:	T 3.15 A, high I2t, 250 V
Fuse F401:	T 3.15 A, high I2t, 250 V
Fuse F402:	T 2.5 A, 250 V

CONSTRUCTION

Housing:	UV-resistant fiber-reinforced composite
Finish:	polyurethane coating
Protection factor:	IP 20

ACCESSORIES

Martin infrared remote control transmitter	P/N 90760010
Martin infrared remote control receiver	P/N 91611047
2-unit flight case	P/N 91510007
G-clamp:	P/N 91602003
Half-coupler clamp:	P/N 91602005
Pantograph	P/N 91602006
Flush mount bracket	P/N 91606009

DICHROIC COLOR FILTERS

Light blue 101	P/N 46401601
Flame red 304	P/N 46401602
Fern green 205	P/N 46401603
Yellow 603	P/N 46401604
Light green 204	P/N 46401605
Pink 312	P/N 46401606
Primary green 206	P/N 46401607
Amber 604	P/N 46401608
Orange 306	P/N 46401609
Deep orange	P/N 46401610
Primary red 308	P/N 46401611
Magenta 507	P/N 46401612
Lavender 508	P/N 46401613
Dark blue 107	P/N 46401614
Medium blue	P/N 46401615
Turquoise 202	P/N 46401616
Blue 104	P/N 46401617
Purple	P/N 46401618
CTC 5500-3400K	P/N 46401619
CTC 3500-5600K	P/N 46401620
UV-transmitter	P/N 46401621
Green 201	P/N 46401622