

MAC 500/E

user manual

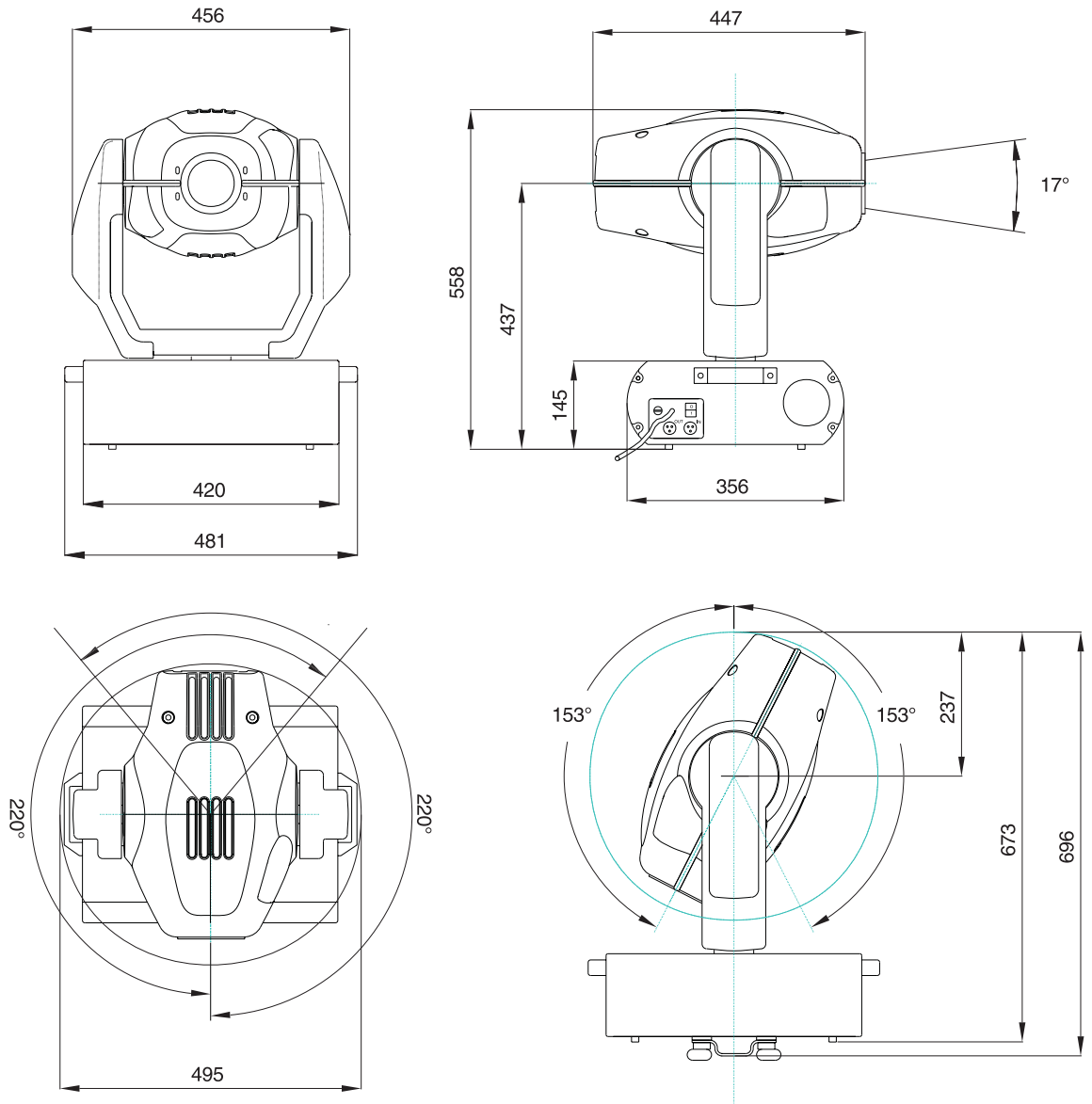

© 1997 - 1999 Martin Professional A/S, Denmark.

All rights reserved. No part of this manual may be reproduced, in any form or by any means, without permission in writing from Martin Professional A/S, Denmark.

Printed in Denmark.

P/N 35000016, Rev. B, 990611-MA

section 1	
Introduction	
Safety precautions	4
section 2	
Setup	
Unpacking	5
Installing or changing the lamp.....	5
Powering the fixture.....	6
Rigging.....	6
Connecting the serial link	7
section 3	
Operation	
Martin RS-485 control	9
DMX-512 control.....	9
Controllable effects	10
section 4	
Control Panel	
Menu navigation	12
Personality settings	13
Address and protocol selection	14
Readouts.....	14
Manual control	15
Stand-alone sequences	15
Utilities.....	16
section 5	
Gobos and Color Filters	
Gobo specifications.....	17
Gobo orientation and positions	17
Changing rotating gobos	19
Changing static gobos	19
Default color filter positions	20
Changing color filters.....	20
section 6	
Maintenance and Basic Service	
Accessing parts	21
Removing the printed circuit board	21
Replacing fuses	22
Changing the XLR pin-out.....	22
Changing voltage and frequency settings	22
Updating software.....	23
Changing lenses	24
Replacing the lamp.....	24
Optimizing lamp alignment	25
Installing the optional head shell safety wire.....	25
Maintenance schedule.....	25
Cleaning	26
Lubrication	26
section 7	
Appendices	
DMX protocol	27
Error messages	31
Troubleshooting	32
Circuit board layout	33
Specifications	34

section 1 INTRODUCTION

Thank you for purchasing the MAC 500/E moving-head spotlight from Martin. Every detail of its construction and programming is designed to make the MAC 500/E extremely bright, quiet and reliable. With proper setup and maintenance, it will provide years of trouble-free operation.

This manual covers the MAC 500 with magnetic ballast and the MAC 500 E with electronic ballast. "MAC 500/E" refers to both models when describing common features and procedures.

This manual describes the features programmed in CPU software version 1.7. The latest news about the MAC 500/E is always available from your dealer and the Martin web site at <http://www.martin.dk>.

Safety precautions

The MAC 500/E is for professional use only. It presents potential risks due to electrical shock, heat and ultraviolet radiation burns, lamp explosion, falls, high-intensity light, and fire. A thorough understanding of the dangers, genuine concern for safety, and attention to detail are required to prevent accidents. **Read this manual before powering or installing the fixture**, follow the safety precautions listed below, observe the warnings in this manual and printed on the fixture, and double check all safety conditions. If you have any questions about how to operate the MAC 500/E safely, please contact your Martin dealer or call the Martin Service hotline for assistance.

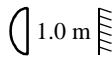
- ALWAYS disconnect the fixture from AC power and allow it to cool before:
 - Changing the transformer or ballast settings
 - Installing or removing the lamp
 - Checking or replacing fuses
 - Removing any cover or part from the fixture
- ALWAYS keep combustible materials (for example fabric, wood, paper) at least 1.0 meters (39 inches) away from the fixture. Keep flammable materials well away from the fixture.
- For protection against dangerous electric shock, ALWAYS ground (earth) the fixture electrically. Use only a source of AC power that complies with local building and electrical codes.
- ALWAYS ensure that the air flow through fans and vents is free and unobstructed.
- When suspending the fixture above ground level, ALWAYS verify that the structure can hold at least 10 times the weight of all installed devices and secure the fixture with an approved safety cable. Block access below the work area whenever installing or removing the fixture.
- To prevent injury due to lamp explosion, ALWAYS protect your eyes with safety goggles and allow the lamp to cool at least 15 minutes before removing the lamp assembly.
- ALWAYS refer service operations not described in this manual to a qualified technician.
- NEVER expose the fixture to rain or moisture.
- NEVER illuminate surfaces within 1 meter of the fixture. 
- NEVER place filters or other materials over the lens.
- NEVER operate the fixture if the ambient temperature (T_a) exceeds 40° C (104° F).
- NEVER look directly into the light from a close distance.
- NEVER operate the fixture without all lenses and covers installed: an unshielded lamp emits dangerous UV radiation that can cause burns and eye damage, and it can explode without warning.
- NEVER modify the fixture or install other than genuine Martin accessories and upgrade kits.
- NEVER lift the fixture by its head.

section 2 SETUP

This section describes the steps required to prepare the MAC 500/E for operation.

Unpacking

The MAC 500/E package includes:

- 2 Fast-Lock clamp brackets
- 5-meter XLR-XLR control cable
- User manual
- 7 extra gobos
- 1 spare rotating gobo spring

The packing material is carefully designed to protect the fixture during shipment - always use it or a custom MAC 500/600 flight case to transport the fixture.

Note: MAC 600 flight cases produced before September, 1997, are not deep enough for the MAC 500/E. These flight cases can be identified by the outside measurements: 860 mm (34") from bottom to top, including wheels, on the outside. Suitable flight cases measure 894 mm (35.2") from bottom to top, including wheels.

Installing or changing the lamp

WARNING!

Disconnect the fixture from AC power before proceeding. Always wear safety goggles to protect your eyes and allow a hot lamp to cool for at least 15 minutes before removing it from the fixture.

The MAC 500/E is designed to work with the Philips MSR-575/2, Philips MSD-575, or the Osram HSR-575/2 discharge lamp. *Installing any other lamp may damage the fixture.* The lamp holder is pre-adjusted at the factory; precise alignment may be necessary due to slight variations between lamps. The procedure is described on page 25.

1. The MAC 500/E must be cool and isolated from AC power. Remove the 2 screws holding the lamp assembly. Gently remove the assembly.

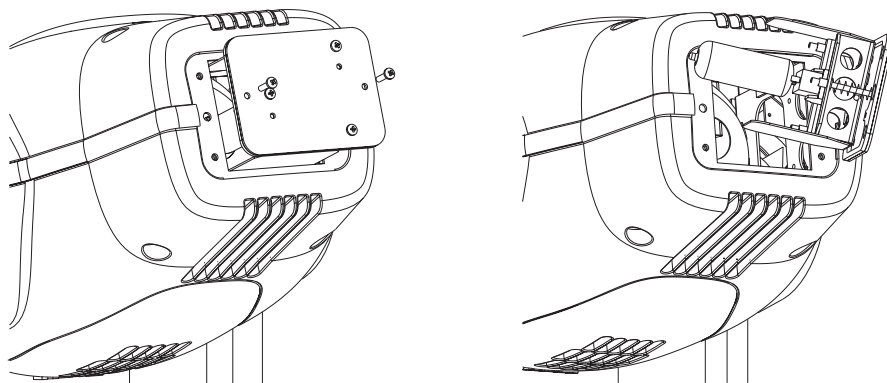

2. If changing the lamp, remove the old lamp from the socket.
3. Holding the new lamp by its ceramic base (do not touch the glass), carefully insert it firmly and squarely into the lamp socket.
4. Clean the glass bulb with the cloth supplied with the lamp, particularly if your fingers touch the glass. A clean, lint-free cloth wetted with alcohol may also be used.
5. Re-insert the lamp assembly and replace the screws.
6. Before turning the lamp on, reset the RLAH and RLST counters. See "Readouts" on page 14.

Powering the fixture

WARNING!

For protection from dangerous electric shock, the fixture must be grounded (earthed). The AC mains supply shall be fitted with a fuse or circuit breaker and ground-fault protection.

Check voltage and frequency settings

The voltage and frequency settings must match the local AC power supply! Operating at the incorrect setting can result in poor light output, shortened lamp life, overheating and damage to the fixture. The settings are printed on the serial number label on the bottom of the base: if the voltage does not match the local supply or the frequency (50/ 60 Hz) is different, then the ballast and/or transformer must be rewired as described on page 22.

Install a plug on the power cord

You may need to install a cord cap that fits your supply on the power cable. Following the manufacturer's instructions, install an approved 3-prong grounding-type plug that fits your supply. Connect the wires to the pins as listed below. The table shows some possible pin identification schemes; if the pins are not clearly identified, or if you have any doubts about proper installation, consult a qualified electrician.

Wire	Pin	Marking	Screw (US)
brown	live	"L"	yellow or brass
blue	neutral	"N"	silver
yellow/green	ground		green

When ready to operate, connect the MAC 500/E directly to AC power. *Do not connect it to a dimmer system; doing so may damage the fixture.* To apply power, set the power switch on the base to the "I" position.

Rigging

WARNING!

Use 2 clamps to rig the fixture. Lock each clamp with both fasteners. The 1/4-turn fasteners are locked only when turned fully clockwise.

Attach an approved safety cable to the base.

The MAC 500/E can be placed directly on the stage floor or rigged in any orientation on a truss. The integrated Fast-Lock system enables quick and easy fastening of the clamp adapters in 4 different positions as shown below. See page 35 for a list of suitable clamps available from Martin.

1. Verify that the rigging clamps (not included) are undamaged and can bear at least 10 times the weight of the fixture. Bolt the clamps securely to the clamp brackets with a grade 8.8 (minimum) M12 bolt and lock nut, or as recommended by the clamp manufacturer.
2. Tip the MAC 500/E on its side or install the clamps while the fixture is in the flight case.
3. Align a clamp with 2 mounting points. Insert the fasteners into the base and turn both levers a full 1/4-turn clockwise to lock. Install the second clamp.
4. Verify that the structure can bear at least 10 times the weight of all installed fixtures, clamps, cables, auxiliary equipment, etc.
5. Working from a stable platform, hang the fixture on the truss. The front of the fixture is indicated by the arrow on the base.

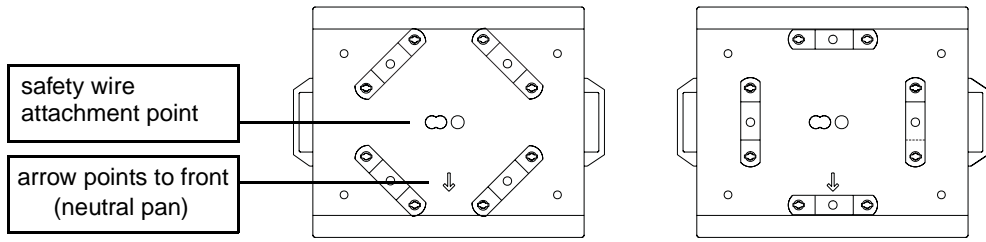

6. Install a safety wire that can bear at least 10 times the weight of the fixture. The attachment point is designed to fit a caribiner clamp. *Never use the carrying handles for secondary attachment.*
7. Tighten the rigging clamps securely to the structure.
8. Verify that there are no combustible materials or surfaces to be illuminated within 1 meter of the fixture, and that there are no flammable materials nearby.

IMPORTANT!

When rigging the fixture within 1 meter of other fixtures, avoid illuminating one fixture with another. The intense light can melt plastic parts.

Connecting the serial link

Tips for building a serial link

1. Use shielded twisted-pair cable designed for RS-485 devices: standard microphone cable cannot transmit DMX data reliably over long runs. For links up to 300 meters (1000 ft.) long, you can use 24 AWG, low capacitance, 85-150 ohm characteristic impedance, shielded cable with 1 or more twisted pairs. For runs up to 500 meters (1640 ft.) use 22 AWG cable. Use an amplifier if the serial link exceeds 500 meters.
2. Never use a "Y" connector to split the link. To split the serial link into branches use a splitter such as the Martin 4-Channel Opto-Isolated RS-485 Splitter/Amplifier.
3. Do not overload the link. Up to 32 devices may be connected on a serial link.
4. Terminate the link by installing a termination plug in the output socket of the last fixture on the link. The termination plug, which is simply a male XLR connector with a 120 ohm, 0.25 watt resistor soldered between pins 2 and 3, "soaks up" the control signal so it does not reflect back down the link and cause interference. If a splitter is used, terminate each branch of the link.

Connecting fixtures

The MAC 500/E has locking 3-pin data input and output sockets that can be configured for use with either DMX or Martin Protocol controllers. **The default pin-out is configured to the DMX-512 standard**, i.e., pin 1 to shield, pin 2 to signal (-) and pin 3 to signal (+).

3-pin to 3-pin Phase-Reversing Cable	3-pin to 5-pin Phase-Reversing Cable	5-pin to 3-pin Phase-Reversing Cable	5-pin to 3-pin Straight Cable	3-pin to 5-pin Straight Cable
Connections Male Female 1 ——— 1 2 ——— 2 3 ——— 3	Connections Male Female 1 ——— 1 2 ——— 2 3 ——— 3 4 5	Connections Male Female 1 ——— 1 2 ——— 2 3 ——— 3 4 5	Connections Male Female 1 ——— 1 2 ——— 2 3 ——— 3 4 5	Connections Male Female 1 ——— 1 2 ——— 2 3 ——— 3 4 5
P/N 11820006	P/N 11820002	P/N 11820003	P/N 11820005	P/N 11820004

1. Connect the controller's data output to the MAC 500/E's data input. For a
 - **DMX controller with 5-pin output:** use a cable with 5-pin male and 3-pin female connectors such as P/N 11820005. Pins 4 and 5 are not used.
 - **DMX controller with 3-pin output:** use a cable with 3-pin male and female connectors such as the one supplied.
 - **Martin RS-485 Protocol controller:** use a phase-reversing cable, such as P/N 11820006, with 3-pin male and female connectors or reconfigure the XLR output.
2. Continue the link: connect the output of the fixture closest to the controller to the input of the next fixture. Use a phase-reversing cable when connecting a DMX-standard (pin 3 +) device to a Martin-standard (pin 3 -) device.
3. Insert a male 120 Ω XLR termination plug in the output of the last fixture on the link.

section 3 OPERATION

This section describes the MAC 500/E's controllable effects and the options for customizing them for your application. Option selection is described in the next section.

Martin RS-485 control

The MAC 500/E may be controlled with the Martin 3032 controller with version 2.04 or later software. To respond to the controller, either the protocol setting (P S E T) must be set to Martin (M A R T) as described in the previous section, or automatic protocol detection (S P E C / A U T O) must be enabled. If automatic protocol detection is enabled, send a dummy command and wait 1 second to allow the fixture to respond before sending real commands.

DMX-512 control

The MAC 500/E may be operated with USITT DMX512 controllers in 4 modes that combine tracking or tracking/vector movement with 8-bit or 16-bit pan/tilt resolution.

Tracking control

Tracking is available in all 4 DMX modes. With tracking control, the controller calculates the positions along the path between an effect's starting point and its ending point. It uses the fade time to calculate the change (delta) of each update or refresh, which the fixture "tracks." For smooth movement with any fade time, the MAC 500/E has a filter algorithm that looks at several position updates (samples), and calculates the ideal speed.

This algorithm is adjustable to compensate for controllers that calculate position changes unevenly. In most cases the default settings work well.

If movement is not satisfactory there are 2 parameters that can be adjusted. The first is the calculation method used and is selected under S P E C / T R A C / M O D E . M O D 1 , the default, calculates speed based on the absolute value of the change in DMX; it is the best choice with controllers that calculate intermediate positions that are close to the line of travel. M O D 2 uses the real value of the DMX delta to calculate speed and is better if the intermediate positions stray significantly from the line of travel.

The second parameter is the number of position updates used to calculate speed. The level is adjustable between 1 and 10 under S P E C / T R A C / C A L . Increasing the number of samples increases the distance over which speed is calculated, making movement smoother but less responsive to sudden changes.

The ideal settings for both parameters will vary from controller to controller: experiment for best results. The real value algorithm (M O D 2) is recommended when using the MAC 500/E with the Martin Lighting Director system.

Vector control

With vector control, available in DMX modes 3 and 4, the fixture is given just 1 position - the end position - and a speed, which is set on a separate channel. *For smooth movement, the fade time must be set to 0, i.e., the effect "bumps" or "snaps" from one position to the next.* With controllers that do not have programmable fade times, vector control provides a way to set speed. Because the end point and speed are known from the beginning, vector control results in smooth movement regardless the fade time or the controller's processing power.

The speed channels allow vector control to be turned off, resulting in tracking control. In addition, they offer a "black-out speed," described below, and overrides of the PTSP (pan/tilt speed) and SCUT (shortcuts) personality settings.

When blackout speed is enabled, effects move at full speed. The dimmer/shutter closes while the effects move to make the transition invisible. Dimmer/shutter strobe and pulse effects, however, override the blackout command.

8-bit versus 16-bit pan/tilt resolution

With 8-bit pan/tilt resolution, the pan and tilt are divided into 256 equal increments. Finer position control and smoother movement is provided in the 16-bit modes, which divide the full pan range into 32,768 increments and the full tilt range into 45,567 increments.

Controllable effects

All moving effects are reset to a “home” position when the fixture is powered up. The fixture can also be reset via DMX if DMX reset (SPEC / dRES) is enabled. There is also a combination of DMX values that allows you to reset the MAC 500/E even if this feature is disabled; see the DMX protocol for details.

An on-the-fly position correction system monitors the position of the color wheels, fixed-gobo wheel, and rotating gobos. If an error is detected, the shutter closes and the effect is reset to its home position. Normal operation resumes immediately thereafter. This feature can be disabled by setting effects feedback (SPEC / EFFb) to OFF.

General operation may be optimized for speed or quietness with the studio mode setting (SPEC / MOdE).

Lamp

The MAC 500/E can be set to automatically strike the lamp within 90 seconds of being powered on by setting the Automatic Lamp On (SPEC / ALON) personality to ON. A delay determined by the fixture address prevents all lamps from striking at the same time.

If Automatic Lamp On is set to off (default), the lamp remains off until a “lamp on” command is sent from the controller. A peak of electric current that can be many times the operating current is drawn for an instant when striking the lamp: striking many lamps at once may cause a voltage drop large enough to prevent lamps from striking or trip the main circuit breaker. Avoid this by programming a “lamp on” sequence that strikes lamps one at a time at 5 second intervals.

Power to the lamp can be turned off from the controller if the DMX Lamp Off (SPEC / dLOF) feature is enabled. There is also a combination of DMX values that allows you to turn off the lamp even if this feature is disabled; see the DMX protocol. *Be careful:* it is not possible to strike the lamp within 8 minutes of having switched it off. The MAC 500/E will store a “lamp on” command and strike the lamp automatically when the 8 minutes have elapsed.

Pan and tilt

The moving head pans 440° and tilts 306°. Movement may be optimized for speed by setting the pan/tilt speed (PTSP) personality to FAST, or for smoothness by setting it to SLOW. The setting may be overridden on the speed channel in vector mode. Setting the movement speed to “blackout” in vector mode causes the shutter to black out the light while the mirror is moving. The pan and tilt channels (DMX) can be inverted and/or swapped for convenience using the pan/tilt (PATI) menu.

Color wheels

The MAC 500/E has 2 9-position-plus-open color wheels, yielding a total of 100 possible combinations. The 4 temperature correction filters and 14 dichroic colors combine in 67 useful ways that can be called on 1 DMX channel. Both wheels can be scrolled, allowing for split color effects, snapped to fixed positions, and continuously rotated in both directions at different speeds. The 67 colors can be called randomly on DMX channel 4.

The Shortcuts (SPEC / SCUT) setting determines whether the wheels take the shortest path to the next position or turn in one direction only. The setting may be overridden on the speed channel in vector mode. Setting the color speed to “blackout” in vector mode causes the shutter to black out the light while the wheels are moving.

Focus

The beam may be focused from 2 meters (6.5 feet) to infinity. The beam angle with the standard lenses is 17°. An optional 23.5° wide-angle lens set is available as well. See “Accessories” on page 35.

Fixed (static) gobos

There are 2 operating modes available for the fixed-gobo wheel, which has 9 positions for metal gobos plus an open position. In “fixed” mode (SPEC / gMOD / FIX), the wheel steps between fixed positions and shakes at variable speeds. In “scroll” mode (SPEC / gMOD / SCRL), the wheel scrolls continuously, shakes at 1 speed, and rotates in 2 directions at variable speed.

Setting the fixed-gobo speed to “blackout” in vector mode causes the shutter to black out the light while the wheel turns from one position to another.

The Shortcuts (SPEC / SCUT) setting determines whether the gobo wheel takes the shortest path to the next position or turns in one direction only. The setting may be overridden on the speed channel in vector mode.

Rotating gobos

The MAC 500/E has 5 rotating positions for glass or metal gobos. Gobos may be rotated in both directions at varying speeds or indexed to any position. The function and gobo are selected on channel 5 and the velocity or index position are selected on channel 6. Setting the rotating-gobo speed to “blackout” in vector mode causes the shutter to black out the light while the wheel turns from one position to another and, if indexing is selected, while the gobo rotates between positions.

To change the gobos, see “Gobo orientation and positions” on page 17.

Iris

The iris diameter ranges from 100 to 15 percent open. There are 6 variable/random pulsating iris effects callable on channel 9. These can be disabled by switching DMX Macros (SPEC / dMAC) off. The iris reflection reduction setting (SPEC / IRR) closes the iris slightly from full open to eliminate a halo effect seen in very early units.

Rotating prism / variable frost

The 3-facet prism can rotate in both directions at varying speeds. There are 8 preprogrammed macros that combine the prism with rotating gobos on channel 10. These can be disabled by switching DMX Macros (SPEC / dMAC) off. Setting the prism speed to “blackout” in vector mode causes the shutter to black out the light while the prism moves in and out.

An optional frost filter may be installed in place of the rotating prism to provide a variable frost effect. If the frost filter is installed, the fixture type personality (SPEC / FTYP) must be set to “FROS” to enable the frost variation of the protocol.

Dimmer / shutter

The mechanical dimmer/shutter system provides smooth, high-resolution 100 percent dimming, “instant” open and blackout, random and variable strobe effects up to 23 Hz, and random and variable pulses in which the dimmer snaps open and slowly dims or snaps closed and slowly opens. The pulse and random strobe effects can be disabled by switching DMX Macros (SPEC / dMAC) off.

The Dimmer Mode (SPEC / dMOD) setting allows you to select between linear or simulated tungsten fade curves. The fade time must be 0 to simulate tungsten dimming.

section 4 CONTROL PANEL

The 4-digit LED control panel on the front of the MAC 500/E allows you to set the address and personalities, read lamp hours and other information, calibrate effects, control the fixture manually, and run stand-alone tests and demo programs. Most of these functions may be performed remotely via the serial link with the MPBB1 Uploader.

The display can be flipped for easy reading by pressing the [↑] and [↓] keys simultaneously. The intensity is adjustable and the display can be set to go out 2 minutes after the last key-press.

Menu navigation

The DMX or Martin address, depending on the protocol setting, and any error messages are displayed when the MAC 500/E is turned on. To enter the menu, press [MENU]. Use the [↑] and [↓] keys to move within the menu. To select a function or submenu, press [ENTER]. To escape a function or menu, press [MENU].

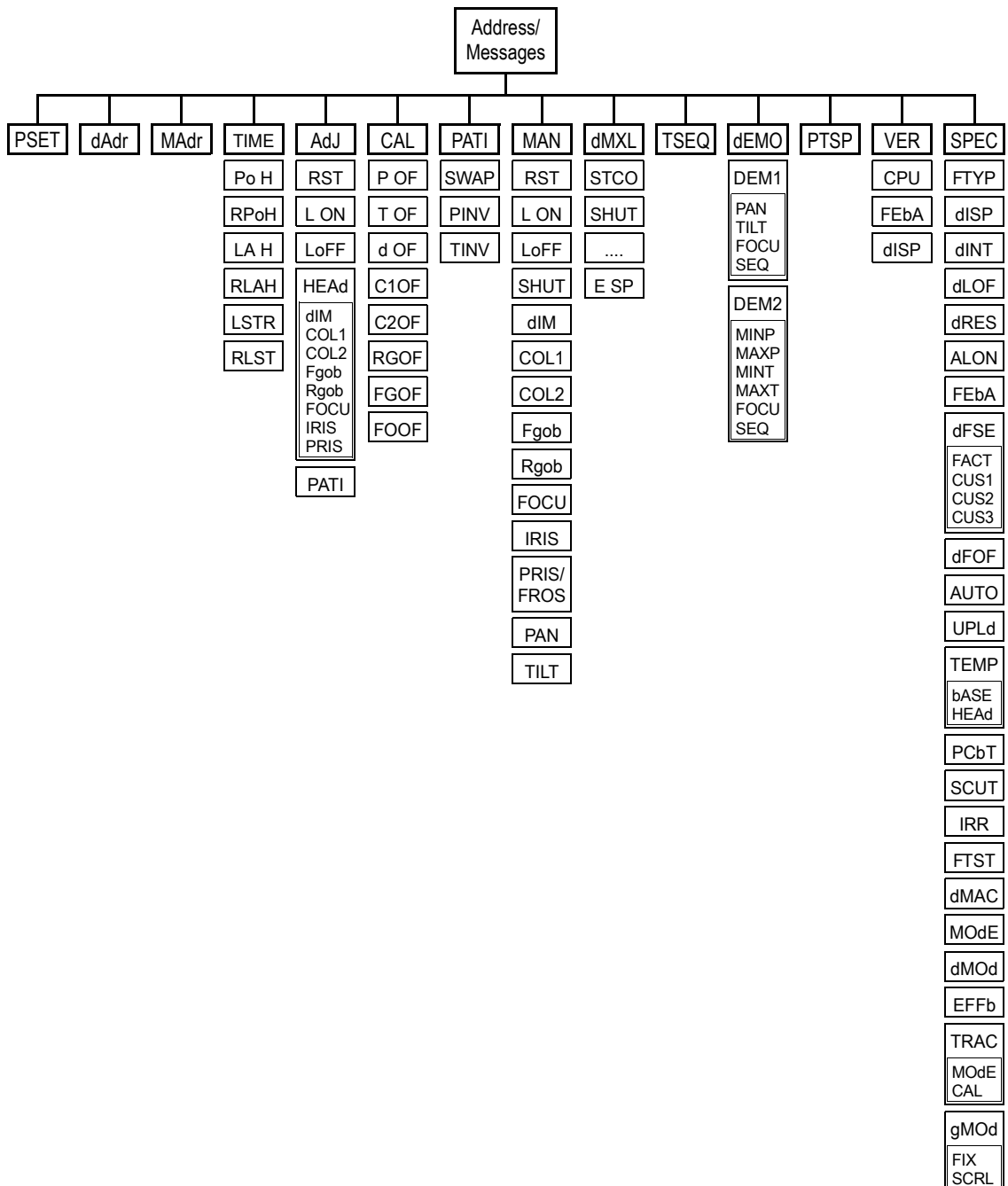

Personality settings

Personality	Path	Options	Effect (Default settings shaded.)
Pan/tilt speed	PTSP	FAST	Optimize movement for speed*
		SLOW	Optimize movement for smoothness*
Pan/tilt swap	PATI / SWAP	ON	Map DMX pan control to tilt channel and vice versa
		OFF	Normal pan and tilt control
Pan inverse	PATI / PINV	ON	Reverse DMX pan control, right → left
		OFF	Normal pan control, left → right
Tilt inverse	PATI / TINV	ON	Reverse DMX tilt control, down → up
		OFF	Normal tilt control, up → down
Fixture type	SPEC / FTYP	PRIS	Operate with rotating prism
		FROS	Operate with optional variable frost
Display on/off	SPEC / dISP	ON	Display stays on
		OFF	Display goes out 2 minutes after last key press
Display intensity	SPEC / dINT	10 - 100	Adjust display intensity
DMX lamp off	SPEC / dLOF	ON	Enable DMX lamp off command
		OFF	Disable DMX lamp off command*
DMX reset	SPEC / dRES	ON	Enable DMX reset command
		OFF	Disable DMX reset command*
Automatic lamp on	SPEC / ALON	ON	Lamp strikes automatically within 90 seconds of power on
		OFF	Strike lamp from controller
Automatic protocol detection	SPEC / AUTO	ON	Enable automatic protocol detection
		OFF	Disable automatic protocol detection
Tracking algorithm	SPEC / TRAC / MOdE	MOd1	Absolute delta value algorithm (for most controllers)
		MOd2	Real delta value algorithm
Tracking samples	SPEC / TRAC / CAL	1 - 10	Tracking mode sample level - default is 6. Higher levels give smoother movement but slower acceleration.
Shortcuts	SPEC / SCUT	ON	Color wheels and fixed-gobo wheel turn the shortest direction*
		OFF	Wheels turn same direction*
DMX macros	SPEC / dMAC	ON	Enable DMX-selectable macros and pulsating effects
		OFF	Disable DMX-selectable macros and pulsating effects
Studio mode	SPEC / MOdE	NORM	Optimize effects for speed
		STUd	Optimize effects for silence
Fixed gobo mode	SPEC / gMOd	FIX	Static gobo wheel steps between full positions
		SCRL	Static gobo wheel scrolls continuously
Dimmer mode	SPEC / dMOd	NORM	Normal dimming curve
		TUNG	Simulated tungsten dimming curve
Pan/tilt feedback	SPEC / FEbA	ON	Enable pan/tilt position correction system
		OFF	Disable pan/tilt feedback. Setting not saved
Effects feedback	SPEC / EFFb	ON	Enable feedback from magnetic sensors on color wheels, fixed-gobo wheel, and rotating-gobo index
		OFF	Disable feedback from magnetic sensors
Iris reflection reduction	SPEC / IRR	ON	Iris opens 95 percent. Recommended for early units only
		OFF	Iris opens 100 percent

* Setting may be overridden via DMX. See the protocol for details.

Address and protocol selection

One of the operating modes shown below must be selected. Factors to consider when selecting a mode will depend on your controller and are discussed in the previous section. Maximum flexibility is provided in mode 4.

Each fixture must be assigned its own channels to receive instructions from the controller. The address, also known as the start channel, is the first channel used. Addresses are independent of the physical link: they may be set in any convenient order. Two MAC 500/Es may share the same address; however, they will receive the same instructions and independent control will not be possible.

Mode	Martin	DMX 1	DMX 2	DMX 3	DMX 4
Movement speed	Vector	Tracking		Tracking and/or Vector	
Pan/tilt resolution	16 bit	8 bit	16 bit	8 bit	16 bit
Channels required	2	12	14	14	16

1. Apply power to the MAC 500/E.
2. If you want to change settings while the MAC 500/E is in a flight case, push [MENU] and [ENTER] simultaneously to disable pan and tilt reset. The partial reset procedure can take 2 - 3 minutes and will result in error messages being displayed; this is not a fault with the fixture.
3. Press the [MENU] key and then press [↑] or [↓] until the display shows PSET. Press [ENTER].
4. Press [↑] or [↓] until the desired protocol (Martin, or DMX mode 1, 2, 3, or 4) appears on the display. Press [ENTER] to confirm.
5. Press [↑] or [↓] until the display shows dAdr (to set a DMX address) or MAdr (to set a Martin address). Press [ENTER] to confirm.
6. Press [↑] or [↓] to select the address. Press [ENTER] to confirm.
7. Press [MENU] to return to the main menu. The address is displayed.

Readouts

Usage readouts (TIME)

Read the total number of power-on hours (POH), power-on hours since last reset (RPOH), total lamp hours (LAH), lamp hours since last reset (RLAH), total number of lamp strikes (LSTR), and the number of lamp strikes since last reset (RLST).

The resettable counters may be used to track overall usage and lamp life. To reset to zero, display the readout and then press [↑] for 5 seconds.

DMX value readouts (dMXL)

Read the DMX start code (STCO) and DMX values received for each effect. This is an easy way to check that the DMX start code is 0 and that the fixture is receiving the expected DMX values.

Software version readouts (VER)

Read the version number of the CPU software (CPU), feedback circuit software (FEBA), and display module software (DISP). The CPU software version is also displayed for a moment at power up.

Temperature readouts (SPEC/TEMP)

Read temperature in the base (bASE) and head (HEAd) in Celsius. Temperatures below 25° C are shown as - 2 5 ; temperatures above 100° C are shown as + 1 0 0 .

The temperature sensors are calibrated at the factory and adjustment should not be necessary. The following procedure calibrates the sensors if they give no or faulty readings.

1. Allow the unit to cool to room temperature (powered off for at least 4 hours).
2. Measure the room temperature in Celsius. (To convert F° to C°, subtract 32° and then multiply by 0.555.)
3. Power up the unit and allow it to reset.

4. Press the [MENU] and [↓] keys at the same time and hold them for 3 seconds until “25” shows in the display.
5. Press the [↑] and [↓] keys until the display shows the temperature measured.
6. Press [ENTER] to save the setting.

Manual control

Manual control (MAN)

The manual control menu permits you to do the following without a controller:

- reset the fixture (RST)
- turn the lamp on and off (L ON, L OFF)
- open, close, and strobe the shutter at 3 speeds (SHUT)
- control the dimmer (dIM)
- move the color wheels to each position and scroll them at 3 speeds (COL1, COL2)
- move the fixed-gobo wheel to each position (Fgob)
- move the rotating-gobo wheel to each position and rotate the gobos at 3 speeds (Rgob)
- control the focus (FOCU)
- control the iris (IRIS)
- insert and rotate the prism (PRIS) at 3 speeds, or, if a frost filter is installed, vary the frost (FROS)
- control pan and tilt (PAN, TILT)

Adjustment (Adj)

The adjustment menu provides manual control for making mechanical adjustments. These should be performed by a qualified technician. The menu provides functions to reset the fixture (RST), turn on and off the lamp (L ON, L OFF), control all effects in the head (HEAD), and move the head to the home and extreme positions (PATI). The HEAD submenu allows the technician to:

- open, close, and strobe the dimmer/shutter (dIM)
- move the color and gobo wheels through their positions (COL1, COL2, Fgob, Rgob)
- move the focus lens to its extreme positions (FOCU)
- open and close the iris (IRIS)
- insert and rotate the prism (PRIS)

Stand-alone sequences

Demonstration programs (dEMO)

This menu offers 2 preprogrammed demonstrations. Demo 1 shows each effect individually and in combination with others at a set home position. Demo 2 pans and tilts within a defined area and shows various effect combinations.

Before running demo 1, set the pan/tilt position (PAN, TILT) to a good location for viewing the effects and then focus (FOCU) the beam. Select SEQ to run the demo. Demo 2 is similar but instead of defining a home position, you define an area such as a screen or wall by setting the minimum and maximum pan and tilt positions (MINP, MAXP, MINT, MAXT). Focus the beam in the center of the area.

Test sequences

Test sequence (TSEQ): Run a general test of all effects.

Printed circuit board test (SPEC/PCBT): This menu provides 4 tests of the circuit board for service use: T1, T2, T3, and LED.

Factory test (SPEC/FTST): This menu provides an effects test (ETST), a movement test (MTST), and a sensor test (STST) used for quality control. The sensor test includes programs for testing sensors on the color and gobo wheels (COL1, COL2, Rgob, and Fgob).

Utilities

Calibration (CAL)

The calibration menu allows you to adjust the effects to achieve total uniformity between fixtures: it is not a substitute for mechanical adjustment. Select dimmer/shutter (d OF), color wheels (C1 OF, C2 OF), rotating-gobo wheel (RGO F), fixed-gobo wheel (FGOF), or focus (FOOF) and adjust the effect's offset with the arrow keys. Offsets are adjustable from 1 to 255 for all effects except the fixed-gobo wheel, which is adjustable from 127 to 129. Press [ENTER] to save the calibration.

Reset default offsets (SPEC/dFOF)

Reset all calibrations to their factory defaults. Select dFOF and press [ENTER] when SURE is displayed.

Reset default personality settings (SPEC/dFSE/FACT)

Return all personality settings (not calibrations) to their factory defaults. Select FACT and press [ENTER] when LOAD is displayed.

Custom configurations (SPEC/dFSE/CUS1, CUS2, CUS3)

Save and load 3 sets of custom configurations. To save a custom configuration, adjust the settings as desired, go to CUS1, CUS2, or CUS3 and press [ENTER] when SAVE is displayed. To load a custom setting, select it and press [ENTER] when LOAD is displayed.

Upload mode (UPLd)

Upload mode prepares the MAC 500/E to receive control software. It is normally engaged automatically when using the MPBB1 Uploader. In certain circumstances, however, you may have to set upload mode manually as described under "Updating software" on page 23.

section 5 GOBOS AND COLOR FILTERS

The MAC 500/E has 5 rotating positions for glass or metal gobos, 9 static positions for metal gobos, and 9 positions for interchangeable dichroic glass color filters in special holders. This section describes how to replace these items.

Gobo specifications

For best results, MAC 500/E gobos should meet the following specifications.

Glass gobos

- Coating: dichroic or enhanced aluminum
- Material: high temperature, Borofloat or better
- Thickness: 1.1- 4.0 mm
- Outside diameter: 27.9 + 0 /- 0.3 mm
- Maximum image diameter: 23 mm

Glass gobos should be made with the artwork reversed on the coated side. This orientation gives the best focus but is not critical. We do not recommend using chrome-coated glass gobos in the MAC 500/E. They absorb more heat than enhanced aluminum gobos and are likely to break or oxidize. If used, their lifetime can be extended somewhat by inserting the gobos with the coated side towards the lamp.

Metal gobos

- Material: aluminum
- Thickness: 0.5 mm
- Outside diameter: 27.9 + 0 /- 0.3 mm
- Maximum image diameter: 23 mm

*Steel metal gobos may give acceptable short term performance. Gobos less than 0.5 mm thick may need to be secured with a drop of high temperature silicone adhesive when used in the static positions.

Gobo orientation and positions

Glass gobos

Note: Glass gobos may be used in the rotating-gobo wheel only. They are too thick for use in the static-gobo wheel.

For correct projection of text and images, the side with the true image must be installed facing in, towards the lamp. For best focus, the coated side of glass gobos should face out, away from the lamp. Textured glass gobos must be inserted with the smooth side facing in, towards the lamp.

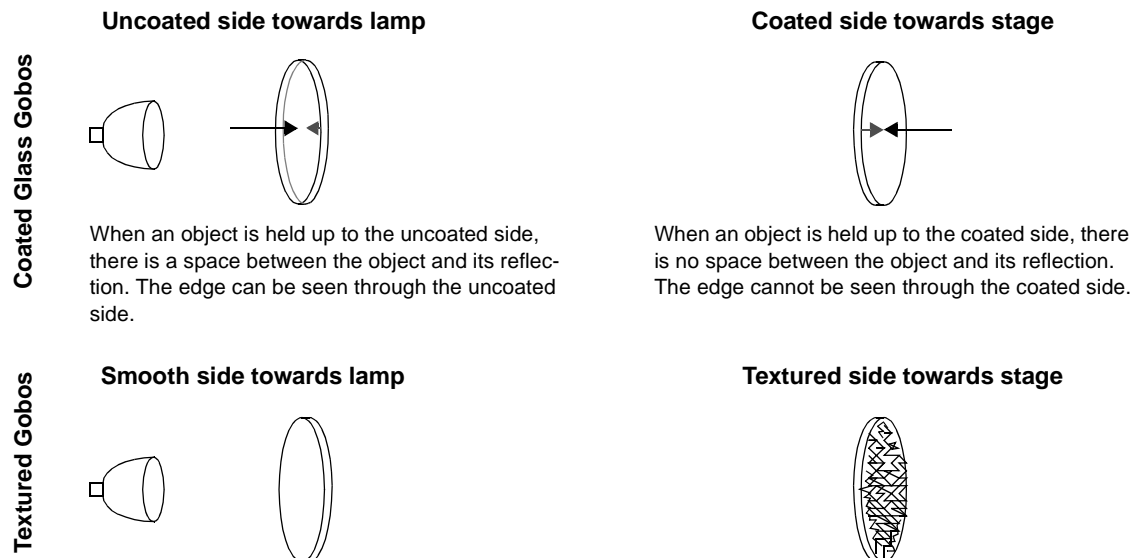

Metal and image gobos

The metal gobos supplied with the MAC 500/E may be used in either wheel. They are black on one side to reduce reflections; the black side must face out, away from the lamp. For correct projection of text and images, the side with the true image must be installed facing in, towards the lamp.

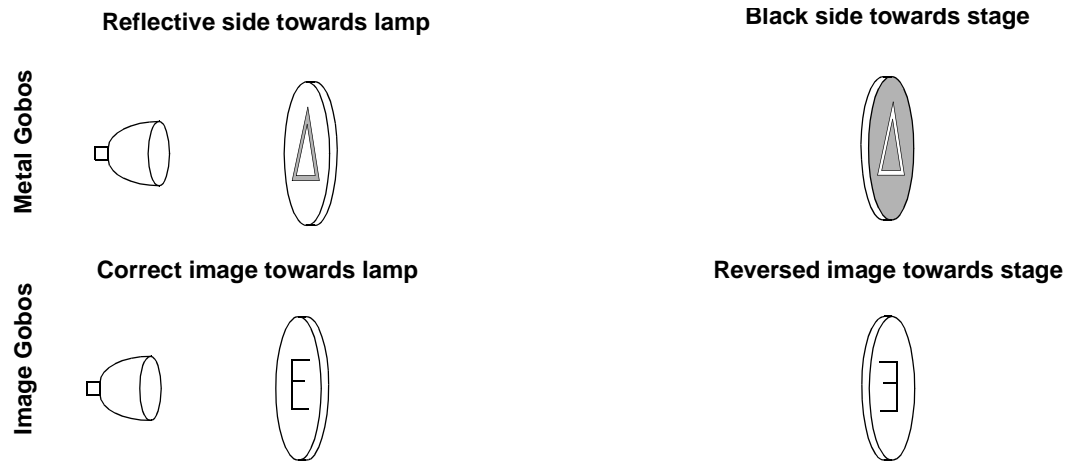

Default gobo layout

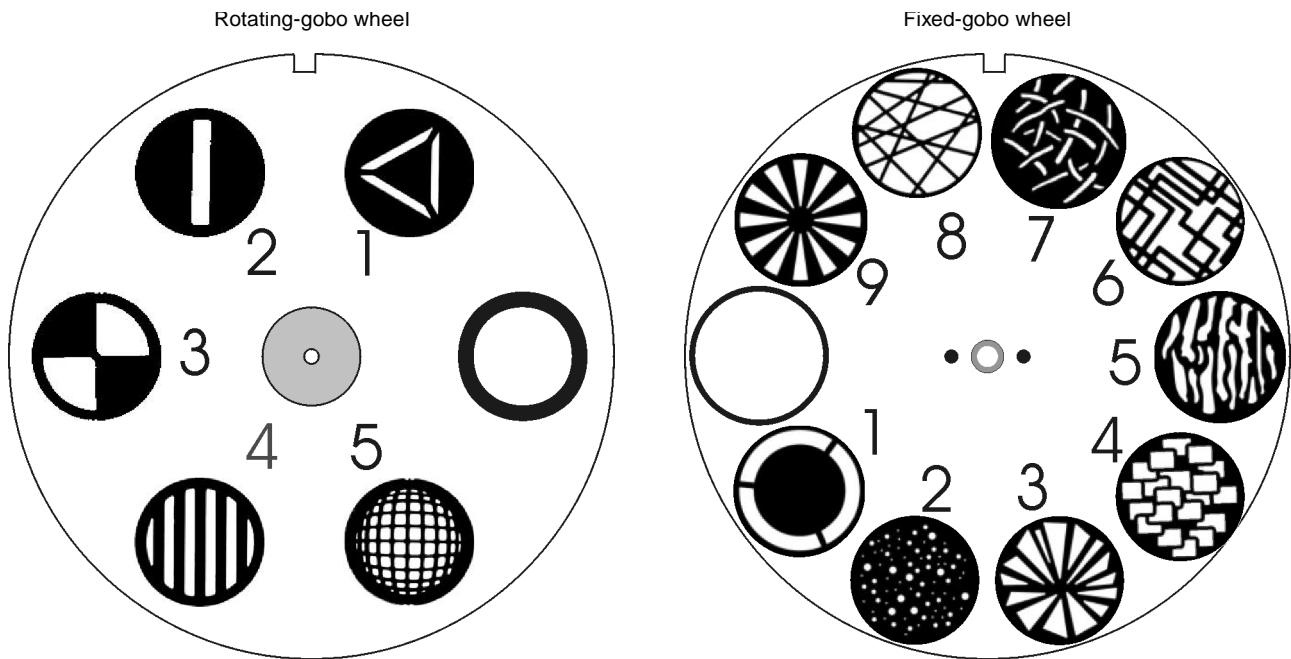

Gobo wheels as seen from front, in open position.

Position	1	2	3	4	5	6	7	8	9
Rotating gobo wheel	Triangle	Bar	Fan	Thin bars	Grid ball	-	-	-	-
	43076004	43076002	43076006	43076005	43076011				
Static gobo wheel	Cone	Dots	Lotus	Bricks	Clouds	Machine	Bamboo	Threads	Pling
	43076012	43076013	43076014	43076015	43076016	43076017	43076018	43076019	43076020

Changing rotating gobos

WARNING!

Disconnect the fixture from AC power before removing any cover.

Without tools

1. Remove the top head cover as described under “Accessing parts” on page 21.
2. Turn the gobo wheel until the easiest access to the desired gobo position is obtained. Turn the color wheel until the open position is over the gobo position.
3. Tilt the head so the lens points down. Push the gobo and retaining spring out of the back of the holder. Avoid letting the spring and gobo fall into the head.
4. Insert the new gobo. See below for proper gobo orientation.
5. Insert the retaining spring with the bend facing out, away from the gobo. Working through the open position in the color wheel, push the gobo and spring all the way down into the gobo holder.

With needlenose pliers

With a little practice, this method is faster than the above method.

1. Turn the gobo wheel until the easiest access to the desired gobo position is obtained. Turn the color wheel until the open position is over the gobo position.
2. Turn the gobo holder until you can see the tab on the holder retaining spring.
3. Grip the tab on the retaining spring with a pair of small (needlenose) pliers. Place your index finger over the spring to prevent it from falling into the fixture. Open the spring and remove it from the gobo holder.
4. Remove the gobo holder from the bearing by pulling it forwards towards the lens.
5. Push the gobo and gobo retaining spring out of the holder.
6. Insert the new gobo. See below for proper gobo orientation. Insert the gobo retaining spring. The bend in the spring faces out, away from the gobo. Push the gobo and spring all the way down into the gobo holder.
7. Replace the gobo holder in the bearing. Do not force the holder into the bearing: it will go in easily if it is installed straight.
8. Grip the retaining ring by the tab with the pliers. Place your thumb on the back of the gobo holder to press it all the way down in the bearing and use your index finger to hold the other end of the spring on the holder. Open the spring and place it in the groove.

Changing static gobos

1. Remove the top head cover as described under “Accessing parts” on page 21.
2. Manually turn the fixed-gobo wheel until the desired gobo is accessible. Turn the color wheel until the open position aligns with the gobo.
3. Using your forefinger, release the gobo by pushing in back slightly towards the lamp. Grasp the gobo by bringing your thumb to the back, and slide the gobo out of the wheel.
4. To place a gobo in the wheel, first turn the gobo so that the black side faces the front and the reflective side faces the lamp. Then, using your thumb and forefinger, slide the gobo into position between the spring clips on the back of the gobo wheel.
5. Verify that the gobo is fully seated in the recessed groove by gently sliding it back and forth. If the gobo is seated correctly, you will be able to feel a tiny amount of movement.

Default color filter positions

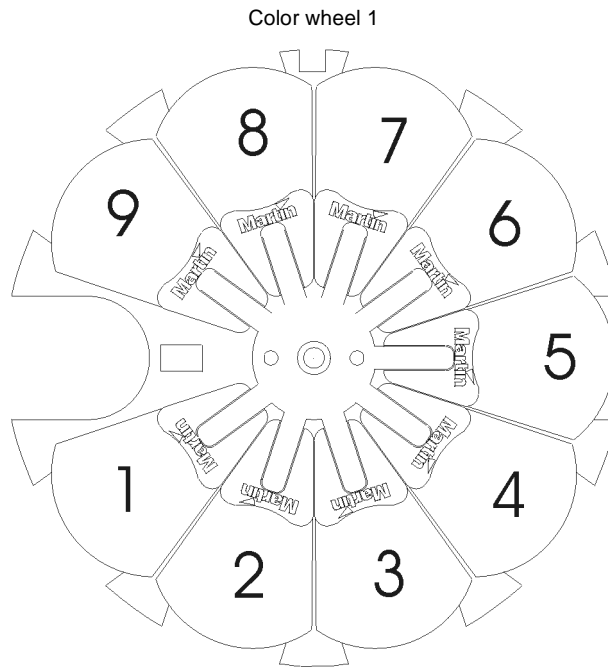

Wheel as seen from front, in open position.

1	2	3	4	5	6	7	8	9
Blue 111	Red 301	Magenta 507	Green 202	Yellow 604	Purple 502	Blue 101	Pink 312	Cyan 401
62327015	62327021	62327023	62327018	62327019	62327025	62327016	62327022	62327017

Changing color filters

WARNING!

Disconnect the fixture from AC power before removing any cover.

1. Remove the top head cover as described under "Accessing parts" on page 21.
2. Manually turn the color wheel until the desired filter is accessible.
3. Using a soft cloth or gloves, gently tilt the outside edge of the filter towards the front lens and remove.
4. To place a filter in the wheel, insert the plastic holder between the spring clip - with the protruding tab facing the lamp - until it snaps into place.

section 6
MAINTENANCE AND BASIC SERVICE

The MAC 500/E operates under challenging conditions presented by heat, humidity, dust, and touring. It requires regular cleaning and lubrication to keep performing at its peak. The maintenance schedule will depend heavily on the application and should be discussed with your Martin technician. This section describes basic maintenance. Refer any service procedure not described here to a qualified technician.

IMPORTANT!

Excessive dust, grease, and smoke fluid buildup degrades performance and causes overheating and damage to the fixture that is not covered by the warranty. If you do not feel completely competent to perform the service, consult qualified service personnel.

Accessing parts

WARNING!

Disconnect the fixture from AC power before removing any cover.

Opening the head

1. Disconnect the fixture from AC power and allow it to cool.
2. Remove the top shell (look at the label on the back of the head to see which side is the top) by turning the 2 fasteners 1/4 turn counterclockwise with a large screwdriver, and lift off the shell.

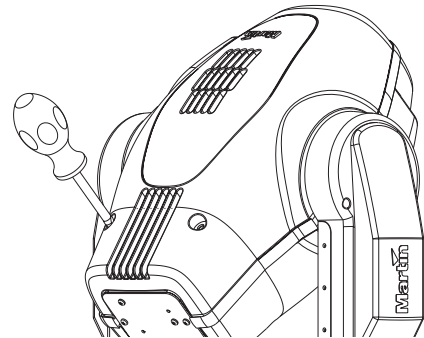

Opening the base

To access base components, remove the 2 cover plates from the top of the base. Each plate is fastened with 4 screws. *Do not remove the curved plates from the side of the base.*

Removing the printed circuit board

1. Disconnect the fixture from AC power. Remove the cover plate from the front of the fixture.
2. Unplug the white plastic wire connectors from the top of the printed circuit board. To unplug a connector, hold the plastic connector - never pull the wires - and pull it straight off the pins.
3. Grasp the black pins on either end of the circuit board and gently pull it out. You may have to guide some wires past the motor housing. Be careful not to knock the copper heat sinks.
4. To replace the circuit board, gently put it back in the base. You may have to guide some wires past the motor housing. Push the black pins down to lock the board in place.
5. Reconnect the wire connectors. The connectors are labelled on the side that faces up, away from the ICs. The connection order is:

PL201: display
PL202: OPT01
PL203: OPT02
PL303: FAN
PL304: 2-pin fan
PL301: GOBO2
PL701: PRISM
PL401: ROPRI
PL411: FOCUS
PL421: IRIS
PL431: GOBO1
PL441: ROGO
PL501: COL1
PL511: COL2
PL521: DIM
PL531: PAN
PL551: TILT

6. Replace the cover before applying power.

Replacing fuses

The MAC 500/E has 4 fuses. The main fuse is located on the power-switch panel and may be replaced without opening the fixture.

The fuses for each of the 3 low-voltage power supplies are located on the printed circuit board. If one of the circuit board LEDs does not light, one of these fuses may be blown.

1. Remove the printed circuit board.
2. Locate and replace the defective fuse with one of the same rating. The fuses are shown on the PCB layout diagram and their values are listed in the specifications.
3. Replace the printed circuit board.

Changing the XLR pin-out

1. Remove the printed circuit board.
2. Position the jumpers for the desired XLR pin-out as shown.
3. Replace the printed circuit board.

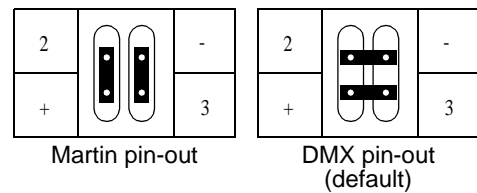

Changing voltage and frequency settings

The voltage and frequency settings must match the local AC power supply! These settings are printed on the serial number label on the bottom of the base. If the voltage is not within 5 percent of the local supply or the frequency (50/60 Hz) is different, then the magnetic ballast and/or transformer must be rewired.

MAC 500 with magnetic ballast

1. *Disconnect the MAC 500 from AC power.* Remove the top covers.
2. Find the correct transformer and ballast terminals for your AC supply in the table below. Consult a qualified electrician if you do not know the AC frequency and voltage.

AC Supply		Transformer		Magnetic Ballast	
Frequency	Voltage	Voltage	Terminal	Setting	Terminal
50 Hz	200-210 V	210 V	4	200 V / 50 Hz	7
50 Hz	210-220 V	210 V	4	230 V / 50 Hz	10
50 Hz	220-235 V	230 V	6	230 V / 50 Hz	10
50 Hz	235-240 V	230 V	6	245 V / 50 Hz	12
50 Hz	240-260 V	250 V	8	245 V / 50 Hz	12
60 HZ	200-217 V	210 V	4	208 V / 60 Hz	4
60 HZ	217-240 V	230 V	6	227 V / 60 Hz	7

3. Locate the transformer: it is on the left end, near the power switch. Move the BROWN and RED transformer wires to the correct terminal. The terminal number is printed in front of the connection tab.
4. Locate the magnetic ballast: it is on the opposite end from the transformer, near the control panel. Move the BROWN ballast wire to the correct terminal. The terminal number is printed in front of the connection tab.
5. Replace the top covers before applying power.

MAC 500 E with electronic ballast

Electronic ballast models that come factory set for 100 V or 120 V have a 10 A main fuse, which is located near the power switch. Units set at 210 V and above have a 6.3 A main fuse. Use a 6.3 A fuse when the *transformer* is set at 200, 210, 220, 230, or 240 V. Use a 10 A time-delay fuse when it is set at 100, 110, or 120 V.

No rewiring of the electronic *ballast* is necessary; it works at any voltage between 100 and 250 volts, and at any frequency between 50 and 60 Hz. The *transformer* must be tapped for the local supply voltage as shown below.

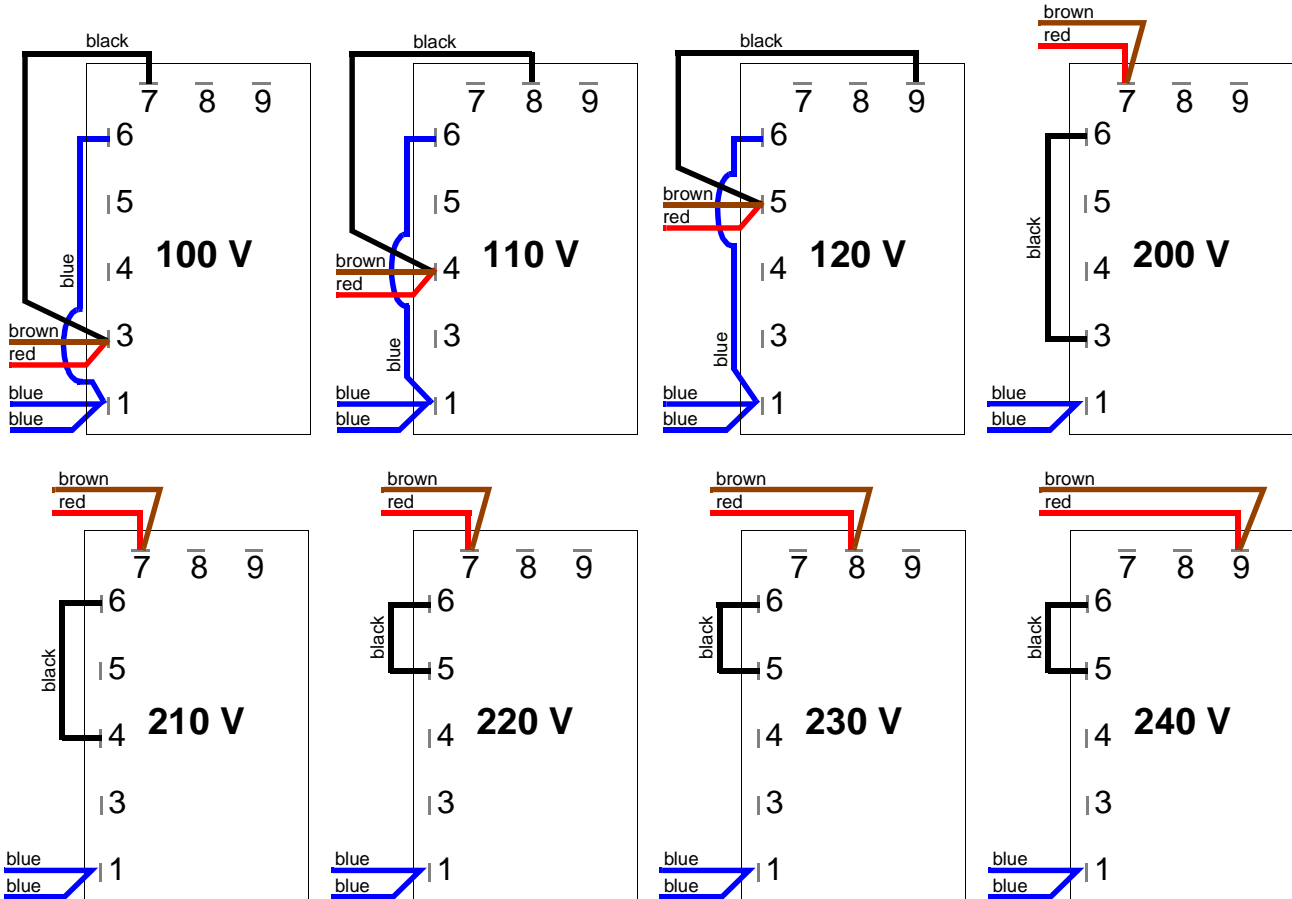

MAC 500 E Transformer Settings

Updating software

The latest software for the MAC 500/E is available from your Martin dealer and the Martin Professional web site. Please read the update notes bundled with the software. Update software is uploaded to the MAC 500/E using a Martin uploader such as the MBPP1.

Normal upload

Connect the uploader to the fixture just like a controller. Under normal conditions, software can be installed from a remote location - there is no need to set the MAC 500/E to boot mode. Please refer to the uploader manual for further instructions.

Boot mode upload

If the data is corrupted during transmission, a check-sum error (CSER) will occur and after 15 seconds the fixture will automatically switch to boot mode (UPLD) and be ready for a boot-mode upload as described below and in the uploader manual.

If a software upload to the MAC 500/E is interrupted, the fixture must be powered off for at least 10 seconds before a new upload can be attempted. When powered on, a check-sum error will occur and it will automatically go into boot mode, ready for a second upload attempt. Select boot mode upload on the uploader.

If there is no functional software in memory, the fixture must be set to boot mode manually before starting the upload. If the control panel works, select UPLd from the SPEC menu and confirm when SURE is displayed by pressing [ENTER].

If the control panel does not work, boot mode can be engaged by moving jumper PL121 on the main circuit board to pins 1 and 2 as follows.

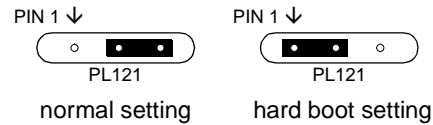

1. Remove the printed circuit board. It may not be necessary to unplug the connectors.
2. Position jumper PL121 to upload mode (INIT) as shown. See also the circuit board layout diagram on page 33.
3. Plug in unplugged connectors, apply power to the MAC 500/E, and proceed with the upload. Refer to the MPBB1 manual for instructions.
4. After the upload, disconnect the fixture from the electricity, move the jumper back to the normal setting, and replace the circuit board.

Changing lenses

Accessory lenses are available to change the standard 17° beam angle to 23.5°. Both the focus lens and the front lens must be changed.

1. Remove the top and bottom head covers.
2. Unscrew and remove the front lens from chassis. Move the dimmer blades out of the way.
3. Slide the focus assembly forward, grasp the focus lens and turn it 60° counterclockwise to unlock. (A service tool is available, see the list of accessories on page 35.) Pull the lens out of the moving bracket.
4. Find the small round notch in the rim of the new focus lens. Turn the lens so that the tabs align with the holes in the bracket and the small notch is at 10 o'clock.
5. Insert the new focus lens squarely into the bracket. Turn the lens 60° clockwise until the locking spring snaps into the notch in the rim.
6. Set the new front lens on the front of the chassis and replace the screws.
7. Replace the top and bottom covers.

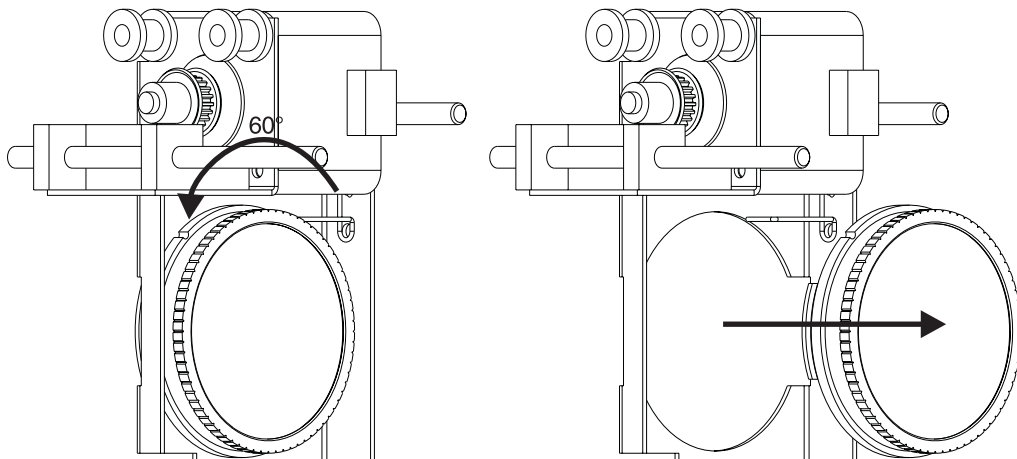

Replacing the lamp

The risk of lamp explosion increases with lamp hours as the quartz envelope gradually weakens. It is recommended that lamp usage not exceed 125 percent of the lamp's rated average life.

The procedure for installing the lamp is described on page 5. After installing the lamp, reset the lamp usage counters as described under "Readouts" on page 14.

Optimizing lamp alignment

The lamp alignment is set at the factory. If, the light distribution is uneven, lamp alignment may be adjusted as follows. A 3 mm Allen wrench is required.

1. **Disconnect the fixture from AC power supply and allow the lamp to cool for 15 minutes.**
2. Make a preliminary adjustment: remove the lamp assembly and turn the 3 lamp adjustment screws to position the lamp-socket plate a distance of 38 mm (1.5") from the access plate (outside measurement) as shown. Replace the lamp assembly.

lamp adjustment screws (3 mm Allen)

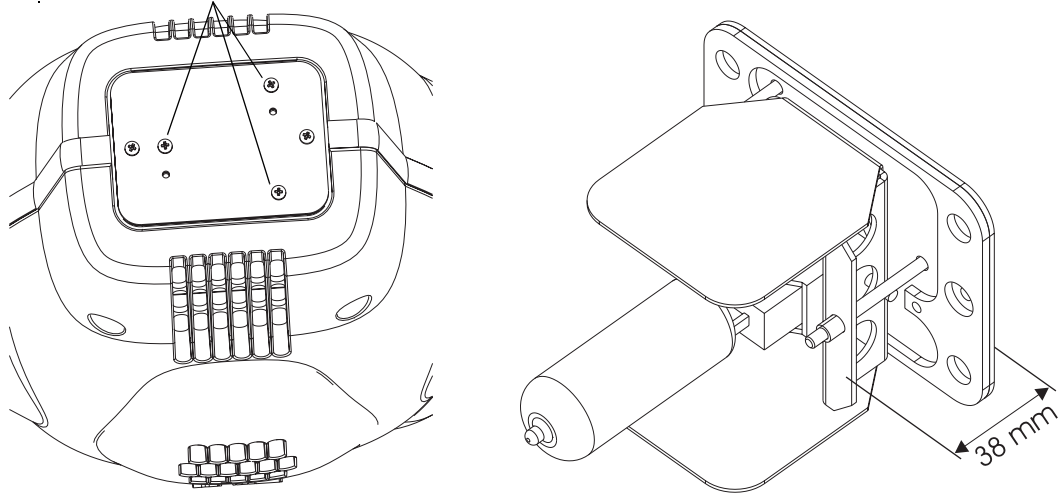

3. Switch on the MAC 500/E and allow it to reset. Using either a controller or the control panel, strike the lamp and focus the light on a flat surface.
4. Center the hot-spot (the brightest part of the beam) by turning the 3 adjustment screws. Turn one screw at a time to drag the hot-spot diagonally across the projected image. If there is no hot-spot, adjust the lamp until the light is even.
5. To reduce a hot-spot, pull the lamp in by turning all three screws clockwise 1/4-turn at a time until the light is evenly distributed.
6. If the light is brighter around the edge than it is in the center, or if light output is low, the lamp is too far back in the reflector. "Push" the lamp out by turning the screws counterclockwise 1/4-turn at a time until the light is bright and evenly distributed.

Installing the optional head shell safety wire

An optional wire (P/N 50300502) for secondary attachment of the plastic shells is available. Two wires are required per fixture. The wire has a closed loop at one end and a hook at the other end. To secure the shell:

1. Remove the head shells as described above.
2. Place the closed loop under a washer and screw in the lamp housing counterweight as shown. Replace the washer and screw and tighten well.
3. Loop the wire around a cross rib between the shell ventilation slots and hook the wire to itself. **Do not attach the hook directly to the plastic rib.**

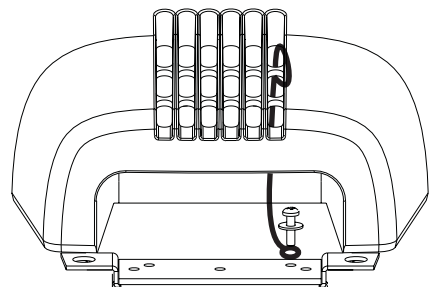

Maintenance schedule

The maintenance schedule will depend heavily on the application and should be discussed with your Martin technician. Cleaning, lubricating and servicing the fixture is best left to a qualified technician. He has the knowledge, experience, tools, lubricants and other materials required to keep the MAC 500/E performing at its best.

Cleaning

Optical components

Be very careful when cleaning the optical components. The colored surface on the dichroic filters is achieved by means of special multi-layer coatings and even small scratches may be visible. Residues from cleaning fluids can bake onto components and ruin them.

1. Allow the components to cool completely.
2. Wash dirty lenses and filters with isopropyl alcohol. A generous amount of regular glass cleaner may also be used, but no residues may remain.
3. Rinse with distilled water. Mixing the water with a small amount of wetting agent such as Kodak Photoflo will help prevent streaking and spotting.
4. Dry with a clean, soft and lint-free cloth or blow dry with compressed air.

Fans

To ensure proper cooling of the fixture, it is important that the fans are free of dust. Vacuum or gently wipe the fans clean if they are dirty.

Lubrication

Use only Martin silicone lubricant, P/N 37302003 (500 ml) or P/N 37302004 (200 ml, in applicator bottle), to lubricate the MAC 500/E. No other lubricant is approved for use. Be careful not to get oil on drive belts or other parts.

The focus mechanism slides back and forth on 2 metal pins. These pins must be lubricated periodically with a drop or two of silicone oil. Check the focus mechanism whenever the head is open for service and lubricate the slides if movement is rough or noisy, or if the slides seem dry.

Check the rotating-gobo bearings whenever the unit is being serviced and lubricate them if movement is rough or noisy. Apply a few drops of oil to the bearings from above. Avoid applying excess lubricant and be careful not to get oil on the other parts.

Depending on conditions, these bearings may need to be cleaned and lubricated periodically by a qualified technician.

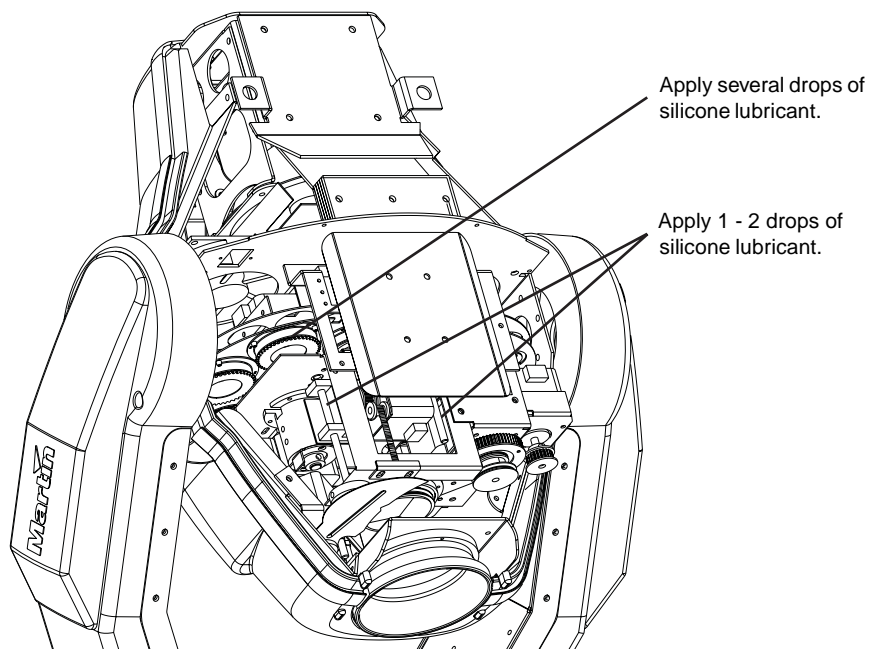

section 7
APPENDICES

DMX protocol

DMX Channel				Start code = 0		
DMX1	DMX2	DMX3	DMX4	Value	Percent	Function
<p style="text-align: center;">1</p> <p>¹ If DMX reset is disabled, a reset command may be sent if color wheel 1 is set to cyan 401(144-148) and color wheel 2 is set to red 308 (157-160).</p> <p>² If DMX lamp off is disabled, a lamp off command may be sent if color wheel 1 is set to cyan 401 (144-148) and color wheel 2 is set to red 308 (157-160).</p>				Shutter, Strobe, Reset, Lamp On/Off		
				0 - 19	0 - 7	Shutter closed
				20 - 49	8 - 19	Shutter open
				50 - 72	20 - 28	Strobe, fast→slow
				73 - 79	29 - 31	Shutter open
				80 - 99	31 - 39	Opening pulse, fast →slow
				100 - 119	39 - 47	Closing pulse, fast →slow
				120 - 127	47 - 50	Shutter open
				128 - 147	50 - 58	Random strobe, fast
				148 - 167	58 - 65	Random strobe, medium
				168 - 187	66 - 73	Random strobe, slow
				188 - 190	74 - 75	Shutter open
				191 - 193	75 - 76	Random opening pulse, fast
				194 - 196	76 - 77	Random opening pulse, slow
				197 - 199	77 - 78	Random closing pulse, fast
				200 - 202	78 - 79	Random closing pulse, slow
				203 - 207	80 - 81	Shutter open
				208 - 217	82 - 85	Reset fixture, see note 1
				218 - 227	85 - 89	Shutter open
				228 - 237	89 - 93	Lamp power on
238 - 247	93 - 97	Shutter open				
248 - 255	97 - 100	Lamp power off: time > 5 seconds, see note 2				
2				0 - 255	0 - 100	Intensity 0 → 100%
3				COLOR 1		
				Color Scroll		
				0 - 16	0 - 6	White → Blue 111
				16 - 32	6 - 13	Blue 111 → Red 301
				32 - 48	13 - 19	Red 301 → Magenta 507
				48 - 64	19 - 25	Magenta 507 → Green 202
				64 - 80	25 - 31	Green 202 → Yellow 604
				80 - 96	31 - 38	Yellow 604 → Purple 502
				96 - 112	38 - 44	Purple 502 → Blue 101
				112 - 128	44 - 50	Blue 101 → Pink 312
				128 - 144	50 - 56	Pink 312 → Cyan 401
				Fixed Colors		
				145 - 148	57 - 58	Cyan 401
				149 - 152	58 - 60	Pink 312
				153 - 156	60 - 61	Blue 101
				157 - 160	62 - 63	Purple 502
				161 - 164	63 - 64	Yellow 604
				165 - 168	65 - 66	Green 202
				169 - 172	66 - 67	Magenta 507
				173 - 176	68 - 69	Red 301
177 - 180	69 - 71	Blue 111				
181 - 184	71 - 72	White				
Continuous Rotation						
185 - 215	73 - 84	CW, fast → slow				
216 - 245	85 - 96	CCW, slow → fast				
246 - 255	96 - 100	Enable alternate color functions on channel 4.				

DMX Channel				Start code = 0		
DMX1	DMX2	DMX3	DMX4	Value	Percent	Function
				COLOR 2: Normal Functions		
				Color Scroll		
				0 - 16	0 - 6	White → CTC 3200-4100
				16 - 32	6 - 13	CTC 3200-4100 → CTC 3200-5600
				32 - 48	13 - 19	CTC 3200-5600 → Blue 104
				48 - 64	19 - 25	Blue 104 → Blue 108
				64 - 80	25 - 31	Blue 108 → Green 206
				80 - 96	31 - 38	Green 206 → Red 308
				96 - 112	38 - 44	Red 308 → Yellow 603
				112 - 128	44 - 50	Yellow 603 → CTC 5500-2900
				128 - 144	50 - 56	CTC 5500-2900 → CTC 5500-4200
				Fixed Colors		
				145 - 148	57 - 58	CTC 5500-4200
				149 - 152	58 - 60	CTC 5500-2900
				153 - 156	60 - 61	Yellow 603
				157 - 160	62 - 63	Red 308
				161 - 164	63 - 64	Green 206
				165 - 168	65 - 66	Blue 108
				169 - 172	66 - 67	Blue 104
				173 - 176	68 - 69	CTC 3200-5600
				177 - 180	69 - 71	CTC 3200-4100
				181 - 184	71 - 72	White
				Continuous Rotation		
				185 - 215	73 - 84	CW, fast → slow
				216 - 245	85 - 96	CCW, slow → fast
				Random Color		
				246 - 248	96 - 97	Fast
				249 - 251	98 - 98	Medium
				252 - 255	99 - 100	Slow
				Alternate Functions (Enable on channel 3.)		
				0-255	0 - 100	67 different colors in following order: white, purple, pink, magenta, red, orange, yellow, green, cyan, blue, black
				Rotating Gobo Selection		
				Set index, direction, and speed on channel 6.		
				0 - 55	0 - 22	Open gobo
				56 - 75	22 - 29	Gobo 1 - Indexing
				76 - 95	30 - 37	Gobo 2 - Indexing
				96 - 115	38 - 45	Gobo 3 - Indexing
				116 - 135	45 - 53	Gobo 4 - Indexing
				136 - 155	53 - 61	Gobo 5 - Indexing
				156 - 175	61 - 69	Gobo 5 - Cont. Rotation
				176 - 195	69 - 76	Gobo 4 - Cont. Rotation
				196 - 215	77 - 84	Gobo 3 - Cont. Rotation
				216 - 235	85 - 92	Gobo 2 - Cont. Rotation
				236 - 255	93 - 100	Gobo 1 - Cont. Rotation
				Rotating Gobo Index and Rotation		
				Select gobo and function on channel 5.		
				Indexing		
				0 - 126	0 - 49	Index CCW
				127	50	Default index
				128 - 255	50 - 100	Index CW
				Continuous Rotation		
				0 - 2	0 - 1	No rotation
				3 - 127	1 - 50	CW, slow → fast
				128 - 252	50 - 98	CCW, fast → slow
				253 - 255	99 - 100	No rotation

DMX Channel				Start code = 0		
DMX1	DMX2	DMX3	DMX4	Value	Percent	Function
				Fixed Gobos		
				Fixed gobo positions		
				0 - 9	0 - 4	Open gobo
				10 - 19	4 - 8	Gobo 1
				20 - 29	8 - 11	Gobo 2
				30 - 39	12 - 15	Gobo 3
				40 - 49	16 - 19	Gobo 4
				50 - 59	20 - 23	Gobo 5
				60 - 69	24 - 27	Gobo 6
				70 - 79	27 - 31	Gobo 7
				80 - 89	31 - 35	Gobo 8
				90 - 102	35 - 40	Gobo 9
7 Gobo mode = fixed (default)				Gobo shake, fast → slow		
				103 - 119	40 - 47	Gobo 9
				120 - 136	47 - 53	Gobo 8
				137 - 153	54 - 60	Gobo 7
				154 - 170	60 - 67	Gobo 6
				171 - 187	67 - 73	Gobo 5
				188 - 204	74 - 80	Gobo 4
				205 - 221	80 - 87	Gobo 3
				222 - 238	87 - 93	Gobo 2
				239 - 255	94 - 100	Gobo 1
				Fixed Gobos		
				0 - 180	0 - 70	Continuous scroll
				Full positions:		
				0	0	Open
				20	8	Gobo 1
				40	16	Gobo 2
				60	24	Gobo 3
				80	31	Gobo 4
				100	39	Gobo 5
				120	47	Gobo 6
				140	55	Gobo 7
				160	63	Gobo 8
				180	70	Gobo 9
7 Gobo mode = scroll (optional)				Gobo shake		
				181 - 183	71 - 72	Gobo 9 shake
				184 - 186	72 - 73	Gobo 8 shake
				187 - 189	73 - 74	Gobo 7 shake
				190 - 192	74 - 75	Gobo 6 shake
				193 - 195	75 - 76	Gobo 5 shake
				196 - 198	77 - 78	Gobo 4 shake
				199 - 201	78 - 79	Gobo 3 shake
				202 - 204	79 - 80	Gobo 2 shake
				205 - 207	80 - 81	Gobo 1 shake
				Continuous rotation		
				208 - 231	82 - 91	CW, fast → slow
				232 - 255	92 - 100	CCW, slow → fast
8				Focus		
				0 - 255	0 - 100	Infinity → 2 meters
				Iris		
				0 - 199	0 - 78	Open → close
				200 - 215	78 - 84	Close
				216 - 229	85 - 90	Pulse opening, fast → slow
				230 - 243	90 - 95	Pulse closing, fast → slow
				244 - 246	96 - 96	Random pulse opening, fast
				247 - 249	97 - 98	Random pulse opening, slow
				250 - 252	98 - 99	Random pulse closing, fast
				253 - 255	99 - 100	Random pulse closing, slow
9						

DMX Channel				Start code = 0		
DMX1	DMX2	DMX3	DMX4	Value	Percent	Function
10 Fixture type = prism (default)				0 - 19	0 - 7	Prism Prism off
				20 - 79	8 - 31	Rotating prism, CCW fast → slow
				80 - 89	31 - 35	No rotation
				90 - 149	35 - 58	Rotating prism, CW slow → fast
				150 - 215	59 - 84	Prism off
				Combined Rotating Prism and Gobo Macros		
				216 - 220	84 - 86	Macro 1
				221 - 225	87 - 88	Macro 2
				226 - 230	89 - 90	Macro 3
				231 - 235	91 - 92	Macro 4
10 Fixture type = frost (optional)				0 - 255	0 - 100	Variable Frost No frost → full frost
11	11	11	11	0 - 255	0 - 100	Pan Left → right (128 = neutral)
-	12	-	12	0 - 255	0 - 100	Pan Fine (LSB) Left → right
12	13	12	13	0 - 255	0 - 100	Tilt Up → down (128 = neutral)
-	14	-	14	0 - 255	0 - 100	Tilt Fine (LSB) Up → down
-	-	13	15	0 - 2 3 - 245 246 - 248 249 - 251 252 - 255	0 - 1 1 - 96 96 - 97 98 - 98 99 - 100	Pan/Tilt Speed Tracking Fast → slow Tracking, normal speed (override PTSP FAST) Tracking, fast speed (override PTSP NORM) Blackout while moving
n/a	n/a	14	16	0 - 2 3 - 245 246 - 248 249 - 251 252 - 255	0 - 1 1 - 96 96 - 97 98 - 98 99 - 100	Effects Speed Dimmer, iris, focus and gobo indexing Tracking mode Fast → slow Tracking with shortcuts disabled, overrides SCUT ON Tracking with shortcuts enabled, overrides SCUT OFF Maximum speed Color 1, color 2, and fixed gobo if gMod = SCRL Tracking mode Speed, fast → slow Tracking with shortcuts disabled, overrides SCUT ON Tracking with shortcuts enabled, overrides SCUT OFF Blackout while moving Fixed gobo if gMod = FIX Normal (as set on effect channel), no blackout Normal, shortcuts disabled, overrides SCUT ON Normal, shortcuts enabled, overrides SCUT OFF Blackout while moving Rotating gobo and prism Normal (as set on effect channel), no blackout Blackout while moving Gobo shake speed if gMod = SCRL Fast Speed, fast → slow Fast
				0 - 2 3 - 245 246 - 255	0 - 1 1 - 96 96 - 100	

Error messages

Display readout	Appears if...	What to do
LERR (Lamp error)	... the lamp doesn't ignite within 10 minutes of receiving the 'Lamp ON' command. Likely reasons are a missing or defective lamp, or insufficient AC voltage.	<ul style="list-style-type: none"> • Check the lamp • Check that the voltage and frequency settings match the local supply.
MERR (Memory error)	...the EEPROM memory cannot be read.	<ul style="list-style-type: none"> • Contact Martin service personnel for assistance.
CSER (Check-sum error)	...a software upload is unsuccessful.	<ul style="list-style-type: none"> • Reload software, see page 23.
****	... there is no communication between the control panel and motherboard. This readout appears briefly when switching on the fixture.	<ul style="list-style-type: none"> • Check fuses and replace accordingly. • Check that cable between control panel and motherboard is connected properly. • Reinstall software.
ShER (Short error)	... the fixture detects the lamp is ON but no 'Lamp ON' command has been received. This can occur if the lamp relay is stuck or if the lamp-power feedback circuit fails. The fixture may be operated but remote lamp on/off may be effected.	<ul style="list-style-type: none"> • Contact Martin service personnel for assistance.
Hot (Hot lamp)	... you attempt to strike the lamp within 8 minutes after having switched it off. The fixture will store the 'Lamp ON' instruction and strike the lamp once the 8 minutes period has elapsed.	<ul style="list-style-type: none"> • Wait until the lamp strikes.
bTER (Base temperature error) HTER (Head temperature error)	...there is a malfunction in the base or head temperature sensing circuit.	<ul style="list-style-type: none"> • Contact Martin service personnel for assistance.
FbEP (Feedback error pan) FbET (Feedback error tilt) FbER (Feedback error pan/tilt)	...pan (FbEp), tilt (FbET) or both (FbER) feedback circuits are malfunctioning. It will still be possible to operate the fixture, though it goes into a "safe" mode where maximum speed is reduced, thus preventing the fixture from losing track of its home position (losing step).	<ul style="list-style-type: none"> • Contact Martin service personnel for assistance.
PAER (Pan time-out) TIER (Tilt time-out)	...the pan or tilt indexing circuit is malfunctioning. The fixture will, after the time-out, establish a mechanical stop, and continue to work normally.	<ul style="list-style-type: none"> • Contact Martin service personnel for assistance.
C1ER (Color wheel 1 time-out) C2ER (Color wheel 2 time-out) FgER (Fixed gobo time-out) RgER (Rot. gobo time-out)	...the magnetic-indexing circuit malfunctions (e.g. sensor defective or magnet missing). After the time-out, the effect in question stops in a random position.	<ul style="list-style-type: none"> • Contact Martin service personnel for assistance.

Troubleshooting

Problem	Probable cause(s)	Remedy
One or more of the fixtures is completely dead.	No power to fixture.	Check that power is switched on and cables are plugged in.
	Primary fuse blown (located at the mains inlet cable).	Disconnect fixture and replace fuse.
	Secondary fuse(s) blown (located on PCB inside base).	Disconnect fixture. Check fuses on PCB and replace.
Fixtures reset correctly but all respond erratically or not at all to the controller.	The controller is not connected.	Connect controller.
	XLR pin-out of the controller does not match pin-out of the first fixture on the link (i.e. signal is reversed).	Install a phase-reversing cable between the controller and the first fixture on the link.
Fixtures reset correctly but some respond erratically or not at all to the controller.	Bad data link connection	Inspect connections and cables. Correct poor connections. Repair or replace damaged cables.
	Data link not terminated with 120Ω termination plug.	Insert termination plug in output jack of the last fixture on the link.
	Incorrect addressing of the fixtures.	Check fixture address and protocol settings.
	One of the fixtures is defective and disturbs data transmission on the link.	Bypass one fixture at a time until normal operation is regained: unplug the XLR in and out connectors and connect them directly together. Have the fixture serviced by a qualified technician.
	XLR pin-out on fixtures does not match (pins 2 and 3 reversed).	Install a phase-reversing cable between the fixtures or swap pins 2 and 3 in the fixture that behaves erratically.
Magnetically indexed effect resets correctly but wanders after fixture reaches operating temperature.	Effect wheel or magnetic sensor requires mechanical adjustment.	Disable effects feedback (page 13). Contact Martin technician for service.
Mechanical effect loses position.	The transformer setting does not match local voltage.	Disconnect fixture. Check transformer setting and correct if necessary.
	Mechanical train requires cleaning, adjustment, or lubrication.	Contact Martin technician for service.
Lamp fails to strike after turning the fixture off and on again, or after a power failure. (MAC 500 E)	Electronic ballast does not recognize that the lamp is off.	Send LAMP OFF command before sending another LAMP ON command. The lamp will strike after an 8 minute delay. See protocol for override if dLOF is set to OFF
No light and "LERR" error message displayed.	The ballast and transformer settings do not match local AC voltage and frequency.	Disconnect fixture. Check ballast and transformer settings and correct if necessary.
	Lamp blown	Disconnect fixture and replace lamp.
	Lamp not installed	Disconnect fixture and install lamp.
Lamp cuts out intermittently.	Fixture is too hot.	Allow fixture to cool. Reduce ambient room temperature. Recalibrate temperature sensors.
	The ballast and transformer settings do not match local AC voltage and frequency.	Disconnect fixture. Check ballast and transformer settings and correct if necessary.

Circuit board layout

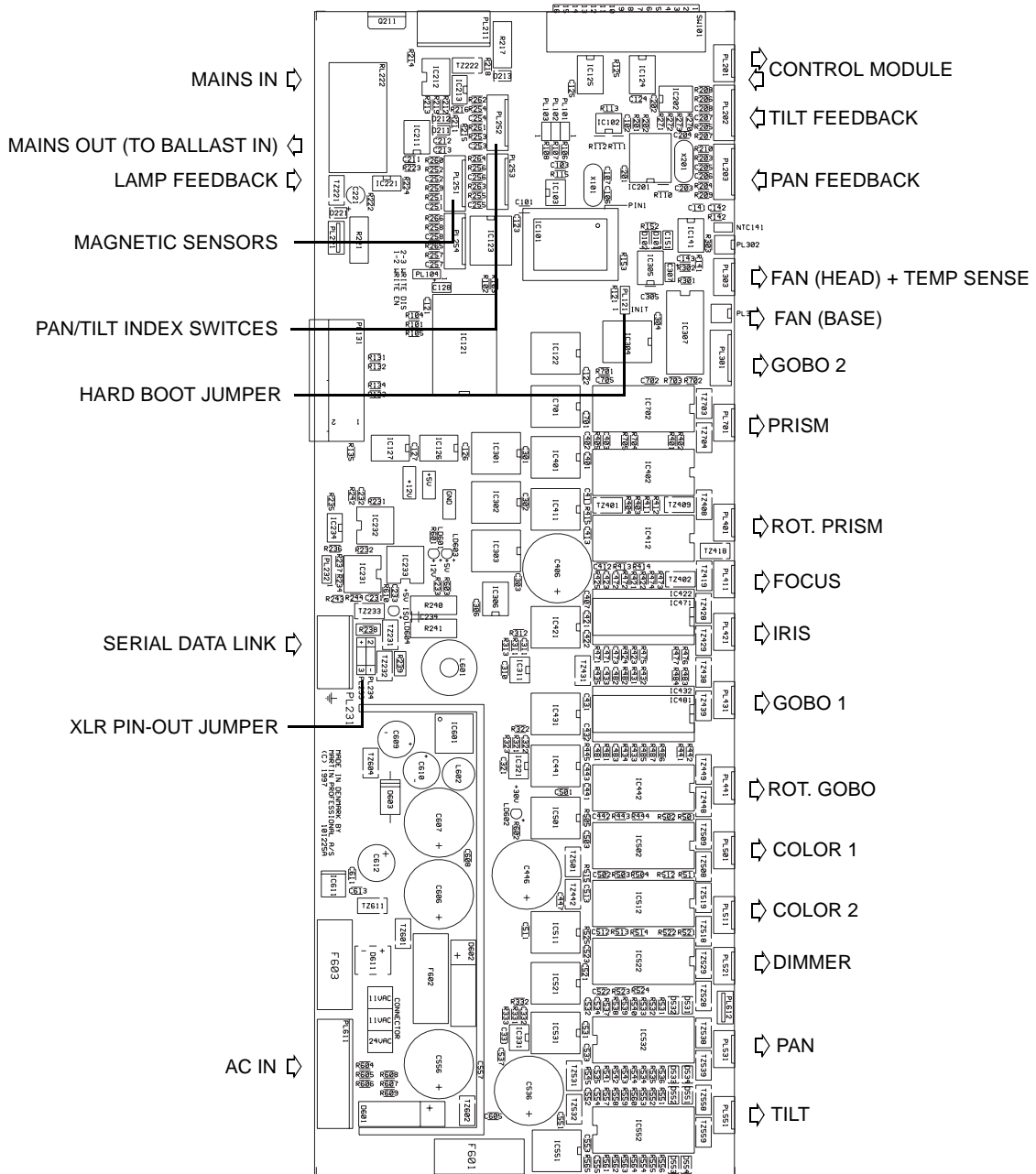

Specifications

Measurements

- Length..... 356 mm (14.0 in)
- Width 481 mm (18.9 in)
- Height (head at tilt limit) 673 mm (26.5 in)
- Weight, MAC 500..... 32.8 kg (72.1 lbs)
- Weight, MAC 500 E 26.1 kg (57.4 lbs)

Electrical, MAC 500

- Ballast taps..... 200/230/245V @ 50 Hz; 208/227V @ 60 Hz
- Power and current* 750 W, 3.4 A @ 230 V / 50 Hz; 750 W, 4.3 A @ 208 V / 60 Hz
- Power factor (PF)* 0.85

Electrical, MAC 500 E

- Transformer taps 100/110/120/200/210/220/230/240 @ 50 - 60 Hz
- Power and current* 690 W, 3.2 A @ 230 V / 50 Hz
- Power factor (PF)* 0.94

Fuses

- Main fuse, MAC 500, MAC 500 E wired between 200 - 240 V time-delay 6.3 A / 250 V, P/N 05020020
- Main fuse, MAC 500 E wired between 100 - 120 V time-delay 10.0 A / 250 V, P/N 05020025
- Fuse F601 time-delay 5.0 A / 250 V, P/N 05020018
- Fuse F602 time-delay 4.0 A / 250 V, P/N 05020016
- Fuse F603 time-delay 0.315 A / 250 V, P/N 05020004

Communication

- Hardware standard RS-485
- Protocols USITT DMX512 (1990) / Martin RS-485
- DMX start code 0
- Recommended cable 24 AWG (min.), low capacitance, 85-150 Ω shielded twisted pair
- Connector type 3-pin XLR male/female (pin 1 = screen, pins 2 and 3 configurable +/-)

Compatible lamps

- Osram HSR-575/2 575 W, 85 lm/W, 1000 h avg. life, 6000K, P/N 97010200
- Philips MSD-575 575 W, 75 lm/W, 2000 h avg. life, 5700K, P/N 97010202
- Philips MSR-575/2 575 W, 85 lm/W, 1000 h avg. life, 6100K, P/N 97010201

Photometric

- Center intensity w/ standard 17° lens set* 246,000 cd
- Center intensity w/ optional 23.5° lens set* 134,000 cd
- Total integrated luminous flux* 9000 lm

Thermal

- Maximum ambient temperature..... 40° C (104° F)
- Maximum surface temperature under normal operating conditions..... 80° C (176° F)

Accessories

Please see the online gobo catalog at <http://www.martin.dk> for additional gobos available from Martin.

• Outdoor Protection Dome.....	90525010
• MPBB1 Uploader	90758410
• Single unit MAC 500/600 flight case	91510001
• Double unit MAC 500/600 flight case.....	91510002
• Triple unit MAC 500/600 flight case.....	91510003
• Optional wide angle (23.5°) lens set w/ bayonet-mount focus lens	91610015
• MAC 500 focus lens retrieval tool.....	50521600
• Frost filter for MAC 500/RS 918, assembled	91611003
• G-clamp	91602003
• Half-coupler clamp	91602005
• Safety wire for head shell (1 piece required for each shell)	50300502
• Retention spring for rotating-gobo holder	17760040
• Rotating-gobo holder.....	17320090
• Retention spring for rotating gobo.....	17760210

* Measured with Philips MSR 575/2 lamp installed

Start code = 0

Implemented from CPU software version 1.7

MAC 500 DMX Protocol



		MODE																																																																				
		1	2	3	4	25					50					75					100					125					150					175					200					225					250																			
L I G H T	1	closed				SHUTTER					STROBE					DIMMER PULSE					RANDOM STROBE					RND PULSE					RESET					OPEN					LAMP ON					OPEN					LAMP OFF*																			
	2	open				←					←					fast					med					slow					open					close					*					218 227					228 237					238 247					248 255									
C O L O R	3	CONTINUOUS COLOR SCROLL (WHEEL 1)																									STEPPED SCROLL										CONTINUOUS ROTATION										CH. 4 ALT																							
	3	position	1	2	3	4	5	6	7	8	9																																																											
	0	white	blue 111	red 301	magenta 507	green 202	yellow 604	purple 502	blue 101	pink 312	cyan 401	145	149	153	157	161	165	169	173	177	181	185	←	215	216	→	245	246	255																																									
4	CONTINUOUS COLOR SCROLL (WHEEL 2)																									STEPPED SCROLL										CONTINUOUS ROTATION										RND COLOR																								
0	white	ctc+	ctc++	blue 104	blue 108	green 206	red 308	yellow 603	ctc--	ctc-	9	8	7	*	5	4	3	2	1	0	145	149	153	157	161	165	169	173	177	181	185	←	215	216	→	245	f m s																																	
Alternate function (enable on ch. 3) 67 colors: white, purple, pink, magenta, red, orange, yellow, green, cyan, blue, black																																																																						
G O B O S	5	OPEN										INDEXED GOBO SELECTION										ROTATING GOBO SELECTION																																																
	0	55					56					G 1					G 2					G 3					G 4					G 5					G 5					G 4					G 3					G 2					G 1													
	6	GOGO ROTATION																																																																				
	0	index ccw										127 128										index cw										255																																						
st 3	continuous cw →										127 128										← continuous ccw										252 st																																							
7	STATIC GOBO SCROLL (STEPPED)															STATIC GOBO SHAKE																																																						
0	open	G 1	G 2	G 3	G 4	G 5	G 6	G 7	G 8	G 9	G 9	G 8	G 7	G 6	G 5	G 4	G 3	G 2	G 1	0	9	10	19	20	29	30	39	40	49	50	59	60	69	70	79	80	89	90	102	103	←	119	120	←	136	137	←	153	154	←	170	171	←	187	188	←	204	205	←	221	222	←	238	239	←	255				
optional	STATIC GOBO SCROLL (CONTINUOUS)										GOBO SHAKE										CONTINUOUS ROTATION																																																	
0	open	G 1	G 2	G 3	G 4	G 5	G 6	G 7	G 8	G 9	9	8	7	6	5	4	3	2	1	208	←	231	232	→	255																																													
8	FOCUS																																																																					
infinity	2 meters																																																																					
E F F E C T S	9	IRIS																				IRIS PULSE																																																
	0	open										close										closed																																																
	0	199										200					215					216 ←					229 ←					230 ←					243																																	
10	PRISM																																																																					
0	out										ccw rotation										stop					cw rotation					out																																							
0	19 20					←					79 80 89 90					→					149 150					215					216					221					226					231					236					241					246					251				
optional	FROST																																																																					
off	full																																																																					
P / T	11	PAN																																																																				
	left	right																																																																				
	- 12 - 12	PAN FINE (LSB)																																																																				
	left	right																																																																				
12 13 12 13	TILT																																																																					
up	down																																																																					
- 14 - 14	TILT FINE (LSB)																																																																					
up	down																																																																					
13 15	PAN/TILT SPEED																																																																					
T 3 fast	slow 245																																																																					
S P E E D	14 16	EFFECTS SPEED																																																																				
	T 3	dimmer, iris, focus, and gobo indexing										←										* Set ch. 3 + ch. 4 as shown to override disabled function.					245					T _s T _f f																																						
	T 3	colors										←										S = normal pan/tilt or shortcuts off (246-248)					245					T _s T _f «»																																						
	0	fixed gobos										no change										F = fast pan/tilt or shortcuts on (249 -251)					245					T _s T _f «»																																						
0	rotating prism and gobo										no change										«» = blackout speed (252-255)					245					S F«»																																							
0											← = variable speed, points to fast															251					«»																																							

Martin Professional A/S

Olof Palmes Allé 18 8200 Aarhus N Denmark Tel.: +45 8740 0000 Fax: +45 8740 0010 www.martin.dk