

CX-2 user manual



P/N 35000080

Martin

Introduction	3
Parts key	5
Lamp installation	6
AC power connection	7
Installation	9
DIP-switch settings	10
Data connection	13
Operation	15
Basic service	18
Troubleshooting	20
DMX protocol	21
Specifications	23

©1999 Martin Professional A/S, Denmark.

All rights reserved. No part of this manual may be reproduced, in any form or by any means, without permission in writing from Martin Professional A/S, Denmark.

Printed in Denmark.

P/N 35000080, Rev. B

INTRODUCTION

1

Thank you for selecting the Martin CX-2. The CX-2 is an automated profile spotlight designed for a 250 watt halogen source. It provides separate color and gobo/effect wheels, continuous electronic dimming, adjustable focus, strobe effects, and multiple control options.

CX-2 SAFETY INFORMATION

Warning! *This product is for professional use only. It is not for household use.*

This product presents risks of lethal or severe injury due to fire and heat, electric shock, and falls. **Read this manual** before powering or installing the fixture, follow the safety precautions listed below and observe all warnings in this manual and printed on the fixture. If you have questions about how to operate the fixture safely, please contact your Martin dealer or call the Martin 24-hour service hotline at +45 70 200 201.

To protect yourself and others from electric shock

- Disconnect the fixture from AC power before removing or installing the lamp, fuses, or any part, and when not in use.
- Always ground (earth) the fixture electrically.
- Use only a source of AC power that complies with local building and electrical codes and has both overload and ground-fault protection.
- Do not expose the fixture to rain or moisture.
- Refer any service operation not described in this manual to a qualified technician.
- Never operate the fixture with missing or damaged lenses and/or covers.

To protect yourself and others from burns and fire

- Never attempt to bypass the thermostatic switch or fuses. Always replace defective fuses with ones of the specified type and rating.
- Keep all combustible materials (for example fabric, wood, paper) at least 0.1 meters (4 inches) away from the fixture. Keep flammable materials well away from the fixture.
- Replace the lamp if it becomes defective or worn out. When replacing the lamp, allow the fixture to cool for at least 5 minutes before opening the fixture or removing the lamp. Protect your hands and eyes with gloves and safety glasses.
- Do not illuminate surfaces within 0.3 meters (12 inches) of the fixture.
- Provide a minimum clearance of 0.1 meters (4 inches) around fans and air vents.
- Never place filters or other materials over the lens.
- The exterior of the fixture can reach temperatures up to 65° C (149° F). Allow the fixture to cool for at least 5 minutes before handling.
- Do not modify the fixture or install other than genuine Martin parts.
- Do not operate the fixture if the ambient temperature (Ta) exceeds 40° C (104° F).

To protect yourself and others from injury due to falls

- When suspending the fixture above ground level, verify that the structure can hold at least 10 times the weight of all installed devices.
- Verify that all external covers and rigging hardware are securely fastened and use an approved means of secondary attachment such as a safety cable.
- Block access below the work area whenever installing or removing the fixture.

UNPACKING

The packing material is carefully designed to protect the fixture during shipment - always use it to transport the fixture.

The CX-2 comes with:

- 1 3-meter, 3-wire IEC power cable
- 1 user manual

PARTS KEY

2

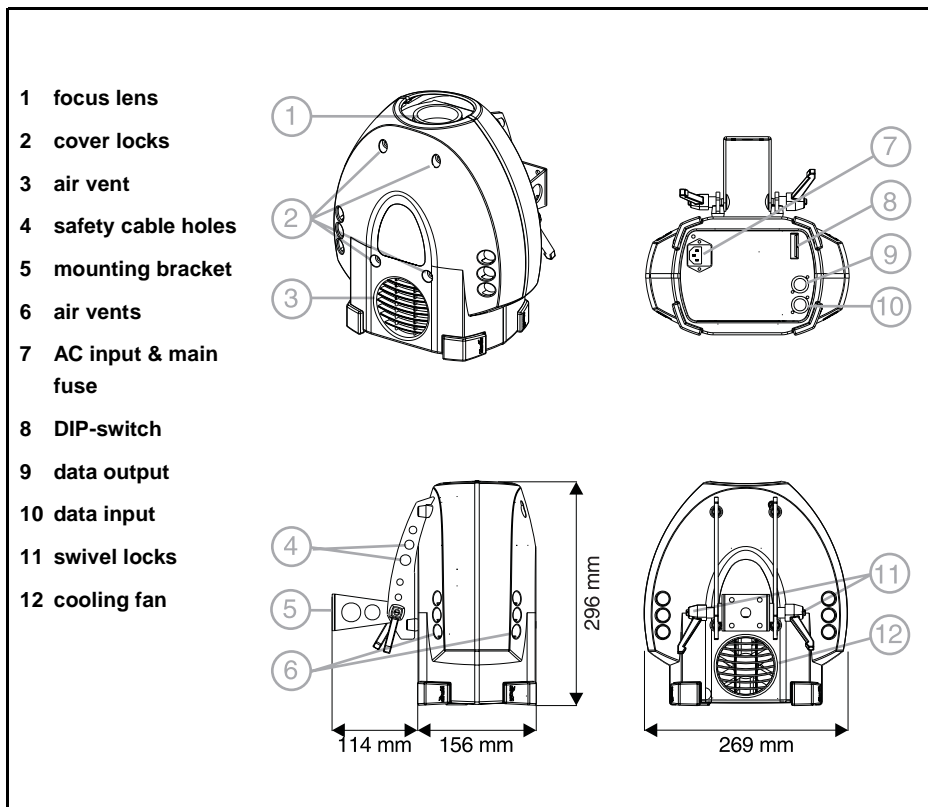

LAMP INSTALLATION

3

The CX-2 uses a 24V, 250W ELC halogen lamp. Two models are available, an economical 300 hour lamp from Philips and a high-output 50 hour lamp from Osram. Installing any other lamp may damage the fixture.

Allow the lamp to cool for at least 5 minutes before packing and moving the fixture. To avoid possible damage, remove the lamp when shipping the fixture.

To install a lamp in the CX-2

Warning! *Always disconnect the fixture from AC power and allow the fixture to cool for 5 minutes before installing a new lamp.*

- 1 Disconnect the fixture from AC power. If replacing a hot lamp, allow it to cool for 5 minutes before removing the cover. The lamp cools faster with the cover in place.
- 2 Release the 4 cover locks by turning them a quarter-turn counterclockwise. Lift the cover straight off.
- 3 To remove the lamp, grasp it by the reflector and pull it out of the holder. Pull the socket straight back off the metal pins. Do not pull the wires.
- 4 Push the socket fully onto the pins of the new lamp.
- 5 Gently push the lamp into the holder until it snaps into place.
- 6 Replace the top cover. To lock the 4 cover locks, turn them a half to a quarter turn clockwise until you feel them click. *Do not overtighten.*

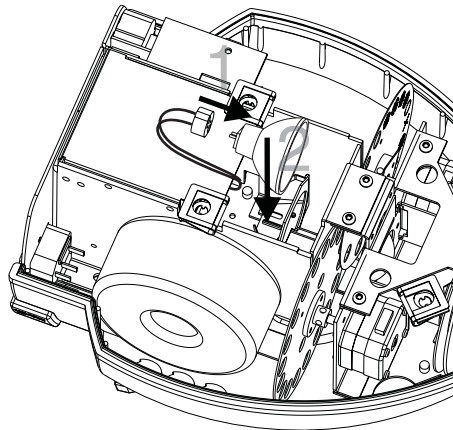

AC POWER CONNECTION

4

Warning! For protection from dangerous electric shock, the fixture must be grounded (earthed). The AC mains supply shall have overload and ground-fault protection.

Important! Check voltage setting before applying power. Do not connect the CX-2 to an electrical dimmer system: doing so can damage the electronics.

Before use verify that the fixture's power supply is correctly tapped for the local AC voltage. The default voltage setting is printed on the serial number label near the AC input. The "EU" version may be set to 230 or 245 V AC and the "US" version may be set to 110 or 120 V AC. Use the setting that is closest to the local supply voltage.

To change the voltage setting

- 1 Disconnect the fixture from AC power. Release the 4 cover locks by turning them a quarter-turn counterclockwise. Lift the cover straight off.
- 2 Locate and disconnect plug PL124 on the back edge of the printed circuit board. It has red, yellow, and blue wires.
- 3 To select 230 V AC (EU version) or 110 V AC (US version), flip and move the plug *up* so that the *red* wire connects to the *top* pin.
- 4 To select 245 V AC (EU version) or 120 V AC (US version), flip and move the plug *down* so that the *red* wire connects to the *bottom* pin.
- 5 Replace the top cover before applying power.

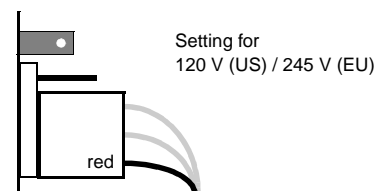
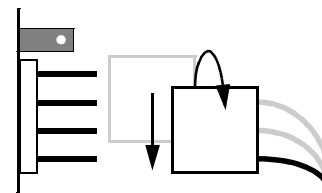
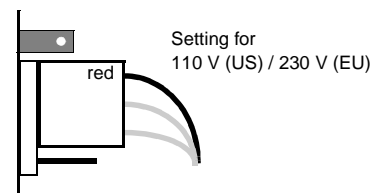

To install a plug on the mains lead

The fixture's mains lead must be fitted with a grounding-type cord cap that fits your power distribution cable or outlet. Consult a qualified electrician if you have any doubts about proper installation.

Important! *Verify that the feed cables are undamaged and rated for the current requirements of all connected devices before use.*

- Following the cord cap manufacturer's instructions, connect the yellow and green wire to ground (earth), the brown wire to live, and the blue wire to neutral. The table below shows some pin identification schemes.

Wire	Pin	Marking	Screw color
brown	live	"L"	yellow or brass
blue	neutral	"N"	silver
yellow/green	ground		green

INSTALLATION

5

The CX-2 can be fastened directly to a suitable surface or to a rigging clamp by means of its adjustable mounting bracket.

Do not lay the fixture flat on its mounting bracket arms or position it so that there is less than 10 cm (4 in.) clearance around the fan and air vents.

For maximum lamp life, do not place the fixture directly on or beside a speaker cabinet or other source of strong vibrations.

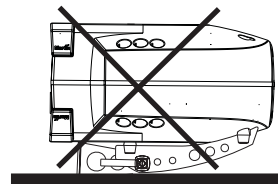

To rig the CX-2

Warning! *Always use a secure means of secondary attachment. Block access below the work area before proceeding.*

- 1 Verify that the clamp (not included) is undamaged and can bear at least 10 times the fixture's weight. Bolt the clamp securely to the bracket with a grade 8.8 (minimum) M12 bolt and lock nut, or as recommended by the clamp manufacturer, through the 13 mm hole in the center of the mounting bracket.
- 2 If permanently installing the fixture, verify that the hardware (not included) and mounting surface can bear at least 10 times the fixture's weight. The four 6.2 mm holes and/or the 13 mm hole in the mounting bracket may be used.
- 3 Verify that the structure can support at least 10 times the weight of all installed fixtures, clamps, cables, auxiliary equipment, etc.
- 4 Working from a stable platform, clamp or fasten the fixture to the structure.
- 5 Install a safety cable that can hold at least 10 times the weight of the fixture through/over the support and through a hole in one of the aluminum arms.
- 6 Loosen the swivel locks and tilt the fixture to the desired angle. Turn the swivel locks clockwise to tighten. If a swivel lock does not tighten fully, pull the handle out, turn it counterclockwise, and retighten. Repeat as necessary.
- 7 Verify that the fixture is located at least 0.3 meters (12 in.) away from the surface to be illuminated and at least 0.1 meters (4 in.) from any combustible materials. Verify that the clearance around the fan and air vents is at least 0.1 meters (4 in.). Verify that there are no flammable materials nearby.

DIP-SWITCH SETTINGS

6

This section describes how to select the DMX address and special settings using the DIP-switch on the end panel.

Important! ***Disconnect the fixture from AC power before changing the DIP-switch setting. Changes take effect after the fixture has been turned off and back on.***

DMX ADDRESS SELECTION

If the CX-2 is to be used with a DMX protocol controller, then the DIP-switch must be set to a DMX control address. The address, also known as the start channel, is the first channel used to receive instructions from the controller. The CX-2 uses 4 channels for full DMX operation. For independent control, each fixture must be assigned its own address and non-overlapping control channels. Two CX-2s may share the same address only if they are to respond identically: they will receive the same instructions and individual control will not be possible.

To set the DMX address

- 1 Select an address for the fixture on your controller.
- 2 Look up the DIP-switch setting for the address on page 11.
- 3 Disconnect the fixture from AC power.
- 4 Set pins 1 through 9 to the ON (1) or OFF (0) position as listed in the table.
- 5 Set pin 10 to the OFF position.
- 6 Set pin 11 to the OFF position for full 4-channel DMX operation or to the ON position for 1-channel DMX operation.

DIP-SWITCH ADDRESS TABLE

Find the address in the table below. Read the settings for pins 1 - 5 to the left and read the settings for pins 6 - 9 above the address. "0" means OFF and "1" means ON.

Important! Pins 10 and 11 must be OFF for full DMX control. Pin 10 must be OFF and pin 11 must be ON for 1-channel DMX control.

DIP-Switch Setting					#9	0	0	0	0	0	0	0	0	1	1	1	1	1	1	1	1
0 = OFF					#8	0	0	0	0	1	1	1	1	0	0	0	0	1	1	1	1
1 = ON					#7	0	0	1	1	0	0	1	1	0	0	1	1	0	0	1	1
#1	#2	#3	#4	#5	#6	0	1	0	1	0	1	0	1	0	1	0	1	0	1	0	1
0	0	0	0	0		32	64	96	128	160	192	224	256	288	320	352	384	416	448	480	
1	0	0	0	0	1	33	65	97	129	161	193	225	257	289	321	353	385	417	449	481	
0	1	0	0	0	2	34	66	98	130	162	194	226	258	290	322	354	386	418	450	482	
1	1	0	0	0	3	35	67	99	131	163	195	227	259	291	323	355	387	419	451	483	
0	0	1	0	0	4	36	68	100	132	164	196	228	260	292	324	356	388	420	452	484	
1	0	1	0	0	5	37	69	101	133	165	197	229	261	293	325	357	389	421	453	485	
0	1	1	0	0	6	38	70	102	134	166	198	230	262	294	326	358	390	422	454	486	
1	1	1	0	0	7	39	71	103	135	167	199	231	263	295	327	359	391	423	455	487	
0	0	0	1	0	8	40	72	104	136	168	200	232	264	296	328	360	392	424	456	488	
1	0	0	1	0	9	41	73	105	137	169	201	233	265	297	329	361	393	425	457	489	
0	1	0	1	0	10	42	74	106	138	170	202	234	266	298	330	362	394	426	458	490	
1	1	0	1	0	11	43	75	107	139	171	203	235	267	299	331	363	395	427	459	491	
0	0	1	1	0	12	44	76	108	140	172	204	236	268	300	332	364	396	428	460	492	
1	0	1	1	0	13	45	77	109	141	173	205	237	269	301	333	365	397	429	461	493	
0	1	1	1	0	14	46	78	110	142	174	206	238	270	302	334	366	398	430	462	494	
1	1	1	1	0	15	47	79	111	143	175	207	239	271	303	335	367	399	431	463	495	
0	0	0	0	1	16	48	80	112	144	176	208	240	272	304	336	368	400	432	464	496	
1	0	0	0	1	17	49	81	113	145	177	209	241	273	305	337	369	401	433	465	497	
0	1	0	0	1	18	50	82	114	146	178	210	242	274	306	338	370	402	434	466	498	
1	1	0	0	1	19	51	83	115	147	179	211	243	275	307	339	371	403	435	467	499	
0	0	1	0	1	20	52	84	116	148	180	212	244	276	308	340	372	404	436	468	500	
1	0	1	0	1	21	53	85	117	149	181	213	245	277	309	341	373	405	437	469	501	
0	1	1	0	1	22	54	86	118	150	182	214	246	278	310	342	374	406	438	470	502	
1	1	1	0	1	23	55	87	119	151	183	215	247	279	311	343	375	407	439	471	503	
0	0	0	1	1	24	56	88	120	152	184	216	248	280	312	344	376	408	440	472	504	
1	0	0	1	1	25	57	89	121	153	185	217	249	281	313	345	377	409	441	473	505	
0	1	0	1	1	26	58	90	122	154	186	218	250	282	314	346	378	410	442	474	506	
1	1	0	1	1	27	59	91	123	155	187	219	251	283	315	347	379	411	443	475	507	
0	0	1	1	1	28	60	92	124	156	188	220	252	284	316	348	380	412	444	476	508	
1	0	1	1	1	29	61	93	125	157	189	221	253	285	317	349	381	413	445	477	509	
0	1	1	1	1	30	62	94	126	158	190	222	254	286	318	350	382	414	446	478	510	
1	1	1	1	1	31	63	95	127	159	191	223	255	287	319	351	383	415	447	479	511	

SPECIAL SETTINGS

DIP-switch pins 1 - 9 are used to select special options in stand-alone and master/slave mode. *To enable these options, pin 10 must be ON.*

Pin 11 toggles between 1 and 4 channel DMX control. It must be OFF for master/slave operation.

Lamp life can be extended by reducing the voltage slightly. Set DIP-switch pin 12 to ON for longer lamp life, or OFF for full output intensity.

Note: the fixture shall be disconnected from AC power when changing DIP-switch settings. Changes take effect after the fixture has been turned off.

Important! Pin 10 must be ON to enable special settings on pins 1 - 9.

Pin	Setting	Effect
1	ON	Music trigger
	OFF	Automatic trigger
2	ON	Stand-alone mode on, single or master fixture
	OFF	Stand-alone mode off / slave fixture
3	ON	Test program for service use
	OFF	Normal operation
4	ON	Slow color and gobo change
	OFF	Fast color and gobo change
5	ON	No effect
	OFF	No effect
6	ON	Random slave color wheel position (set on slave fixture)
	OFF	Slave color wheel position same as master
7	ON	Random slave gobo wheel position (set on slave fixture)
	OFF	Slave gobo wheel position same as master
8	ON	Invert slave color wheel position (set on slave fixture)
	OFF	Slave color wheel position same as master
9	ON	Invert slave gobo wheel position (set on slave fixture)
	OFF	Slave gobo wheel position same as master
10	ON	Enable special settings with pins 1 - 9
	OFF	Enable DMX address with pins 1 - 9
11	ON	1-channel mode on
	OFF	1-channel mode off
12	ON	Reduced power / longer lamp life
	OFF	Full power / maximum intensity

DATA CONNECTION

7

This section describes how to connect fixtures to a controller.

RECOMMENDED CABLE

A reliable data connection begins with the right cable. Standard microphone cable cannot transmit DMX data reliably over long runs. For best results, use cable specifically designed for RS-485 applications. Your Martin dealer can supply high quality cable in various lengths.

CONNECTIONS

The CX-2's XLR data sockets are wired with pin 1 to ground, pin 2 to signal - (cold), and pin 3 to signal + (hot). This is the standard pin assignment for DMX devices.

One or more adaptor cables may be required to connect the CX-2 to the controller and/or other lights because many devices have 5-pin connectors and others may have reversed signal polarity, that is, pin 2 hot and pin 3 cold.

5-pin to 3-pin Adaptor	
Male	Female
1	1
2	2
3	3
4	
5	

P/N 11820005

3-pin to 5-pin Adaptor	
Male	Female
1	1
2	2
3	3
	4
	5





P/N 11820004

3-pin to 3-pin Phase-Reversing Adaptor	
Male	Female
1	1
2	3
3	2

P/N 11820006

To connect the data link

- 1 Connect a data cable to the controller's data output. If controller has a 5-pin output, use a 5-pin male to 3-pin female adaptor cable (P/N 11820005).
- 2 Lead the data cable from the controller to the first fixture. Plug the cable into the fixture's data input.
- 3 Connect the output of the fixture closest to the controller to the input of the next fixture. If connecting to a fixture with reversed-polarity (pin 3 cold), insert a phase-reversing cable between the two fixtures.
- 4 Continue connecting fixtures output to input. Up to 32 devices may be connected on a serial link.
- 5 Terminate the link by inserting a male termination plug (P/N 91613017) into the data output of the last fixture. A termination plug is simply an XLR connector with a 120 ohm, 0.25 W resistor soldered across pins 2 and 3.

Male Termination Plug	Female Termination Plug
Male XLR 1 2  120 3  120	Female XLR 1 2  120 3  120
P/N 91613017	P/N 91613018

OPERATION

8

FULL DMX OPERATION

For DMX operation, the CX-2 must be connected to a DMX controller as described under “Data connection” on page 13. DIP-switch pins 1 - 9 must be set to the DMX address as described on page 10. Pins 10 and 11 must be set to OFF.

DMX CHANNEL DESCRIPTION

See also the DMX protocol on page 21.

Channel 1 controls the light intensity and the strobe rate. It also allows you to execute a “stand-alone” program with random color and gobo change using automatic or music trigger.

All effect wheels are reset to their home position when the fixture is powered up; they can also be reset from the controller by sending a reset command on channel 1.

Channel 2 controls the position of the color wheel. When set to 100 percent, the wheel moves to random positions using the trigger selected on channel 1.

Channel 3 controls the position of the gobo wheel. When set to 100 percent, the wheel moves to random positions using the trigger selected on channel 1.

Channel 4 controls the speed of effect wheel rotation, allowing you to vary the speed on controllers without cross-faders. If your controller has cross-faders, and you use them, then set channel 4 to the “tracking” speed (0 percent).

1-CHANNEL DMX OPERATION

The CX-2 may be operated in 1-channel mode with the MC-1 or any DMX controller. For 1-channel operation, connect the controller as described on page 13. *DIP-switch pin 11 must be set to ON.*

If using the MC-1, select DMX channel 1. If using a DMX controller, any channel within the controller’s range may be assigned.



The single-channel functions are shown below.

DMX value	Percent	Function
0 - 10	0 - 4	Blackout (light off)
11 - 20	5 - 7	Open (light on)
21 - 80	8 - 31	Strobe
81 - 115	32 - 45	Random action with slow music trigger
116 - 140	46 - 55	Random action with medium music trigger
141 - 175	56 - 68	Random action with fast music trigger
176 - 210	69 - 82	Random action with random music trigger
211 - 255	83 - 100	Manual trigger area, crossover at 240 (94%)

STAND-ALONE OPERATION

The CX-2 automatically operates in stand-alone mode with music trigger if there is no control signal.

Operation can be modified using the special settings described on page 12. To enable the special settings, DIP-switch pin 10 must be ON.

Important! *The fixture transmits control signals on the data link when operated in stand-alone mode (with DIP-switch pins 2 and 10 ON). To prevent damage to the electronics, do not connect a stand-alone fixture to other stand-alone fixtures or to a controller.*

MASTER / SLAVE OPERATION

Multiple CX-2s can be connected together, without a controller, for synchronized “master/slave” operation in which the slave fixtures mimic the behavior of the master fixture.

To connect units for master / slave operation

- 1 Disconnect all fixtures from AC power.
- 2 Connect the output of one CX-2 to the input of the next CX-2.
- 3 Connect additional CX-2s output to input. Up to 32 may be connected.
- 4 Terminate the link on both ends by inserting a female termination plug into the data input of the first fixture and a male termination plug into the data output of the last fixture. A termination plug is simply an XLR connector with a 120 ohm, 0.25 W resistor soldered across pins 2 and 3.

To set the master

Important! Set only 1 fixture as master (with DIP-switch pin 2 and 10 ON): errors and damage can occur if there is more than 1 master.

- 1 Set DIP-switch pins 2 and 10 to ON.
- 2 Set DIP-switch pins 3, 5, 6, 7, 8, 9, and 11 to OFF.
- 3 Set DIP-switch pins 1, 4, and 12 ON or OFF, as desired, to select the options described on page 12.

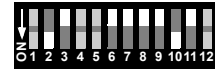

To set a slave

OPTION 1 (SPECIAL OPTIONS DISABLED)

- 1 Set DIP-switch pin 1 to ON.
- 2 Set pins 2 - 11 to OFF.
- 3 Set pin 12 ON for longer lamp life or OFF for higher intensity.



OPTION 2 (SPECIAL OPTIONS ENABLED)

- 1 Set DIP-switch 10 to ON.
- 2 Set pins 1, 2, 3, 4, 5 and 11 to OFF.
- 3 Set DIP-switch pins 6, 7, 8, 9, and 12 ON or OFF, as desired, to select the options described on page 12.



BASIC SERVICE

9

The CX-2 requires simple routine maintenance. The maintenance schedule depends heavily on the operating environment; please consult a Martin service technician for recommendations.

Any service procedure not described here should be referred to a qualified technician.

Important! *Excessive dust, grease, and smoke fluid buildup degrades performance and causes overheating and damage to the fixture that is not covered by the warranty.*

Warning! *Disconnect the fixture from AC power before removing any cover.*

CLEANING

To clean optical components

Use care when cleaning optical components. The surface of the color filters is fragile and small scratches may be visible.

- 1 **Disconnect the fixture from AC power and allow the components to cool completely.**
- 2 **Release the 4 cover locks by turning them a quarter-turn counterclockwise. Lift the cover straight off.**
- 3 **Blow or vacuum away loose dust. Remove residues from lenses and filters with a soft cloth or cotton swabs wetted with isopropyl alcohol. Regular glass cleaner may also be used, but no residues may remain.**
- 4 **Rinse with distilled water. Mixing the water with a small amount of wetting agent such as Kodak Photoflo will help prevent streaking and spotting.**
- 5 **Dry with a clean, soft and lint-free cloth or blow dry with compressed air.**
- 6 **Replace the top cover. To lock the 4 cover locks, turn them a half to a quarter turn clockwise, until you feel them click. *Do not overtighten.***

To clean the fan and air vents

To maintain adequate cooling, dust must be cleaned from the fan and air vents periodically.

- 1 Remove the data and power cables and stand the fixture on end.
- 2 Remove dust and dirt from the fan blades and vent grills using a soft brush, cotton swab, vacuum, or compressed air.

REPLACING FUSES

The CX-2 has 2 fuses. The main fuse holder is built in to the mains input socket. The secondary fuse is located on the printed circuit board.

Warning! *Never replace fuses with ones of a different rating!*

To replace the main fuse

- 1 Unplug the mains cable from the input socket. Pry open the fuse holder and remove the fuse.
- 2 Replace the fuse with one of the same type. The fuse rating is listed on serial number label.

To replace the secondary fuse

- 1 Disconnect the fixture from AC power. Release the 4 cover locks by turning them a quarter-turn counterclockwise. Lift the cover straight off.
- 2 The fuse is located right behind the data input connector. Pry out the defective fuse and replace it with one of the same rating.
- 3 Replace the cover before applying power.

TROUBLESHOOTING

10

Problem	Probable cause(s)	Remedy
One or more of the fixtures is completely dead.	No power to fixture.	Check that power is switched on and cables are plugged in.
	Primary fuse blown.	Replace fuse.
	Secondary fuse blown.	Replace fuse.
Fixtures reset correctly but all respond erratically or not at all to the controller.	The controller is not connected.	Connect controller.
	XLR pin-out of the controller does not match pin-out of the first fixture on the link (i.e. signal is reversed).	Install a phase-reversing cable between the controller and the first fixture on the link.
Fixtures reset correctly but some respond erratically or not at all to the controller.	Bad data link connection	Inspect connections and cables. Correct poor connections. Repair or replace damaged cables.
	Data link not terminated with 120Ω termination plug.	Insert termination plug in output jack of the last fixture on the link.
	Incorrect addressing of the fixtures.	Check DIP-switch settings.
	One of the fixtures is transmitting as a master or is defective.	Bypass one fixture at a time until normal operation is regained: unplug both connectors and connect them directly together. Have the defective fixture serviced by a qualified technician.
An effect fails to reset correctly.	The effect requires mechanical adjustment.	Contact Martin technician for service.
No light.	Lamp missing or blown	Disconnect fixture and replace lamp.
Lamp cuts out intermittently or burns out too quickly.	Fixture is too hot.	Allow fixture to cool.
	The transformer setting does not match local AC voltage.	Check AC setting.

DMX PROTOCOL

A

Channel	Value	Percent	Function
1	0 - 4	0 - 1	Dimmer, Strobe, Reset Light off
	5 - 154	2 - 60	Dimmer, closed to open
	155 - 169	61 - 66	Dimmer full open
	170 - 229	67 - 89	Strobe, fast to slow
	230 - 239	90 - 93	Stand-alone, music trigger
	240 - 249	94 - 97	Stand-alone, auto trigger
	250 - 255	98 - 100	Reset
	2	0 - 5	0 - 1
6 - 11		2 - 4	Open / Light blue 101
12 - 17		4 - 6	Light blue 101
18 - 23		7 - 9	Light blue 101 / Fern green 205
24 - 29		9 - 11	Fern green 205
30 - 35		11 - 13	Fern green 205 / Red 304
36 - 41		14 - 16	Red 304
42 - 47		16 - 18	Red 304 / Yellow 603
48 - 53		18 - 20	Yellow 603
54 - 59		21 - 23	Yellow 603 / Magenta 507
60 - 65		23 - 25	Magenta 507
66 - 71		26 - 27	Magenta 507 / Medium blue 108
72 - 77		28 - 30	Medium blue 108
78 - 83		30 - 32	Medium blue 108 / Deep orange 302
84 - 89		33 - 35	Deep orange 302
90 - 95		35 - 37	Deep orange 302 / Light green 204
96 - 101		37 - 39	Light green 204
102 - 107		40 - 42	Light green 204 / Cyan 104
108 - 113		42 - 44	Cyan 104
114 - 119		44 - 46	Cyan 104 / Pink 312
120 - 125		47 - 49	Pink 312
126 - 131		49 - 51	Pink 312 / Blue 111
132 - 137		52 - 53	Blue 111
138 - 143		54 - 56	Blue 111 / Amber 604
144 - 149		56 - 58	Amber 604
150 - 155		59 - 61	Amber 604 / Primary red 308
156 - 161		61 - 63	Primary red 308
162 - 167		63 - 65	Primary red 308 / Primary green 206
168 - 173		66 - 68	Primary green 206
174 - 179		68 - 70	Primary green 206 / Orange 306
180 - 185		70 - 72	Orange 306
186 - 191		73 - 75	Orange 306 / Split-color 1
192 - 197	75 - 77	Split-color 1	
198 - 203	78 - 79	Split-color 1 / Split-color 2	
204 - 209	80 - 82	Split-color 2	
210 - 255	82 - 100	Random "stand-alone" position w/ music or auto trigger	

Channel	Value	Percent	Function
2	0 - 11	0 - 4	Gobo Wheel
	12 - 23	5 - 8	Open
	24 - 35	9 - 13	Frost
	36 - 47	14 - 18	Virus
	48 - 59	19 - 23	Dot circle
	60 - 71	24 - 27	Spokes
	72 - 83	28 - 32	Atomic
	84 - 95	33 - 37	Dot cross
	96 - 107	38 - 41	Dot cone
	108 - 119	42 - 46	Holes 3
	120 - 131	47 - 51	Clouds 2
	132 - 143	52 - 55	Highways
	144 - 155	56 - 60	Worms 3
	156 - 167	61 - 65	XL iris
	168 - 179	66 - 70	L iris
	180 - 191	71 - 74	M iris
	192 - 203	75 - 79	S iris
	204 - 215	80 - 84	XS iris
216 - 255	85 - 100	Closed	
			Random "stand-alone" position w/ music or auto trigger
4	0 - 2	0 - 1	Color / Gobo Speed
	3 - 255	2 - 100	Tracking (speed function off)
			Fast to slow

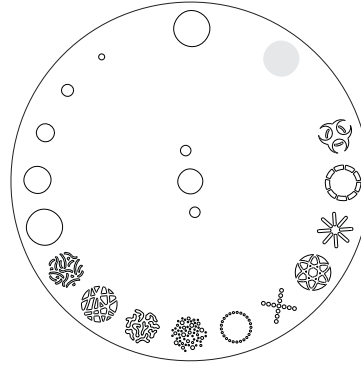

SPECIFICATIONS

B

PHYSICAL

Size (L x W x H):296 x 269 x 270 mm (11.7 x 10.6 x 12.1 in)
Weight:5.5 kg (12.1 lbs)

THERMAL

Maximum ambient temperature (Ta): 40° C (104° F)
Maximum surface temperature: 65° C (149° F)

CONTROL AND PROGRAMMING

DMX-512 (1990) control: 1 / 4 channel, tracking and vector
Stand-alone control: automatic & music trigger, master/slave configurable
Data pinout: 3-pin XLR - pin 1 shield, pin 2 cold (-), pin 3 hot (+)

AC SUPPLY

AC input: 3-pin IEC male socket
Wiring options, "EU" model: 230/245 V, 50-60 Hz
Wiring options, "US" model: 110/120 V, 50-60 Hz
Maximum power and current: 250 W, 1.1 A @ 230 V

FUSES

Primary fuse, EU model: 2.5 AT / 250 V, P/N 05020010
Primary fuse, US model: 5.0 AT / 250 V, P/N 05020018
Secondary fuse: 2.0 AT / 250 V, P/N 05020009

CONSTRUCTION

Housing: UV-resistant fiber-reinforced composite
Finish: black, integral color

INSTALLATION

Minimum distance to combustible materials: 0.1 m (4 in)
Minimum distance to illuminated surfaces: 0.3 m (12 in)
Minimum clearance around fan and air vents: 0.1 m (4 in)

ACCESSORIES

MC-1 Controller, EU: 90718000
MC-1 Controller, US: 90718100
OSRAM 50 h ELC halogen lamp: 97000104
Philips 300 h ELC halogen lamp: 97000106
G-clamp: 91602003
Half-coupler clamp: 91602005



CX-2 4-Channel DMX Protocol

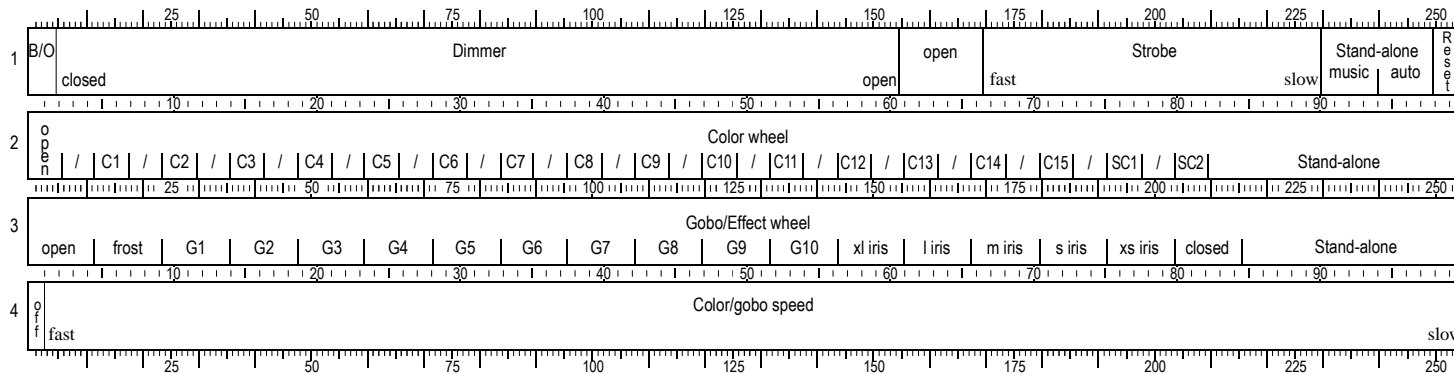

CX-2 1-Channel DMX Protocol

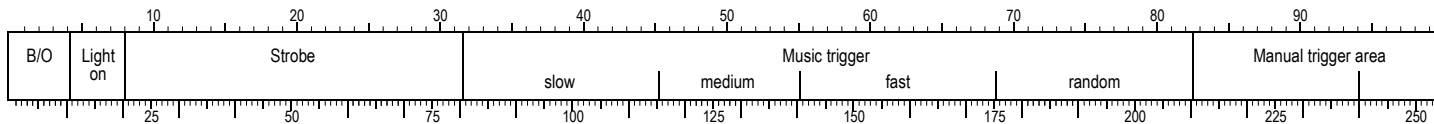

Martin Professional A/S

Olof Palmes Allé 18 8200 Aarhus N Denmark Tel.: +45 8740 0000 Fax: +45 8740 0010 Internet: www.martin.dk