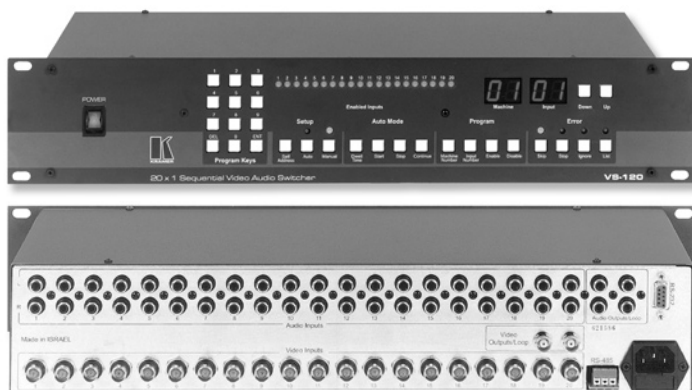
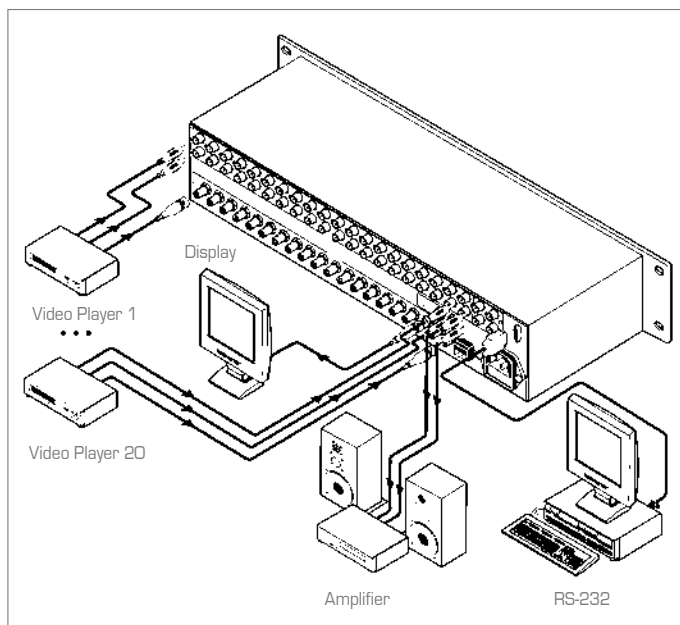

VS-120**20x1 Composite Video & Stereo Audio Switcher/Scanner**

The **VS-120** is a high performance switcher and scanner for composite video and unbalanced audio signals. When configured as a scanner, it will cycle through selected inputs at pre-determined intervals.

**FEATURES**

- **Bandwidth** - 25MHz (-3dB).
- **Dual Outputs** - 2 composite video and stereo audio.
- **Dual Mode** - Configure as a 20x1 switcher or scanner.
- **Expandable** - Cascade multiple units up to 200 Inputs.
- **Vertical Interval Switching.**
- **Control** - Front panel switching & set up, RS-232 (K-Router™ Windows® - based software is included), & RS-485.
- **Standard 19" Rack Mount Size** - 2U.

TECHNICAL SPECIFICATIONS

INPUTS:	20 video 1Vpp/75Ω on BNC connectors. 20 audio stereo, 1Vpp/50kΩ on RCA connectors.
OUTPUTS:	1 video, 1Vpp/75Ω on 2 BNC connectors, parallel connected. 1 audio stereo, 1Vpp/100Ω on 2 x 2 RCA connectors, parallel connected. DB-9 for RS-232, terminal block connectors for RS-485.
VIDEO BANDWIDTH (-3dB):	25MHz.
AUDIO BANDWIDTH (-3dB):	20kHz.
DIFF. GAIN:	1.3%.
K-FACTOR:	< 0.05%.
DISPLAY:	4 seven - segment display LEDs, 20 LED status display.
SWITCHING:	Vertical interval.
DWELL TIME:	1 Sec - 60 Sec.
ERROR DETECTION:	Sync detection.
CONTROL:	12 key keypad control, 17 touch switch setup controls, RS-232, RS-485.
POWER:	230VAC, 50/60Hz (115VAC, U.S.A) 6.7VA.
DIMENSIONS:	19 inch (W), 7 inch (D), 2U (H) rack mountable.
WEIGHT:	4.1kg. (9.1lbs.) approx.
ACCESSORIES:	Power cord, Windows® - based control software, Null modem adapter.

