

VM-5AD

1:5 Audio Distribution Amplifier



The Kramer **VM-5AD** is a high performance distribution amplifier for balanced mono or unbalanced stereo audio signals on XLR connectors. It takes a mono or stereo input and distributes the signal to five identical outputs.

FEATURES

- **Level (Gain) Controls.**
- **Mic or Line Input Level Selection.**
- **Balanced/Unbalanced Input Selection.**
- **S/N Ratio - 88dB.**
- **Desktop Size** - Compact size. Can be rack mounted in a 1U rack space with the optional RK-MEDN adapter.

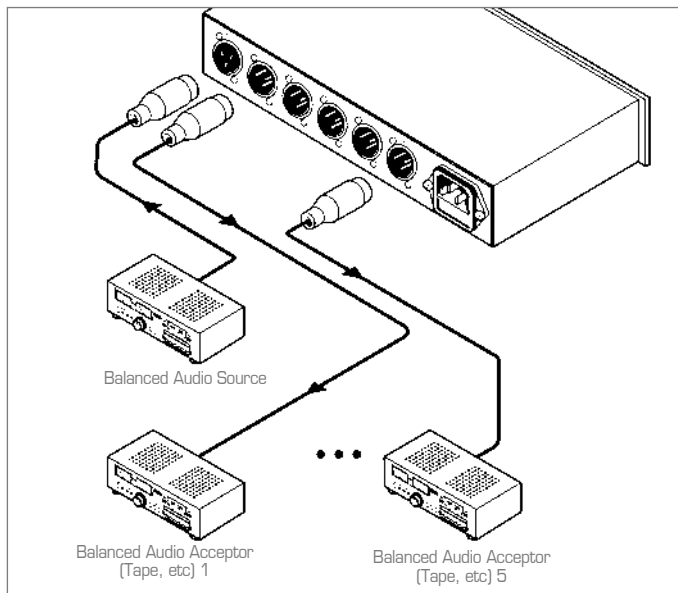

TECHNICAL SPECIFICATIONS

INPUT:	One balanced mono audio, or unbalanced stereo, up to 18Vpp/50k Ω on a female XLR connector. Mic state - one balanced mono Mic or unbalanced stereo Mic - 5mV/10k Ω .
OUTPUTS:	5 balanced mono audio or unbalanced stereo, up to 20Vpp/50 Ω on male XLR connectors.
AUDIO BANDWIDTH (-3dB):	80kHz.
S/N RATIO:	88dB.
CHANNEL MATCHING:	> 60dB.
THD:	0.011%.
LEVEL RANGE:	20dB.
POWER SOURCE:	230VAC, 50/60Hz (115V U.S.A.), 3.4VA.
DIMENSIONS:	24.5cm x 18cm x 4.5cm (9.6" x 7" x 1.8", W, D, H).
WEIGHT:	1.2kg. (2.7lbs.) approx.
ACCESSORIES:	Power cord.
OPTIONS:	RK-MEDN rack kit holds one unit in one 19" vertical rack space.

