



---

**KRAMER ELECTRONICS, Ltd.**

# **USER MANUAL**

**Vertical Interval Switcher**

**Model:**

**VS-4X4YC**

**IMPORTANT: Before proceeding, please read paragraph entitled  
"Unpacking and Contents"**

# USER MANUAL ADDENDUM

## Vertical Interval Switcher

### Model VS-4x4YC

---

---

Responding to customer demand, the factory default of the VS-4x4YC switcher is now set for Protocol 2000 (and not as section 13.1 states).

Your VS-4x4YC switcher has 2 built-in communication protocols. Choose to operate your VS-4x4YC switcher using:

- Protocol 2000 (via the K-ontrol or K-Router software) to control different switchers or switchers/matrix groups from one screen
- The old protocol (via the K-switch software) for simple and fast control of a single switcher or several interconnected machines

When not using the K-switch, K-ontrol or K-Router software, it is recommended to operate using Protocol 2000, which provides more control over the switchers, and is more advanced than the old protocol supported by the K-switch software.

Set your VS-4x4YC switcher to Protocol 2000 by setting DIP 5 OFF. Set your VS-4x4YC switcher to the old protocol by setting DIP 5 ON.

Get full details of Protocol 2000 via the Technical Support section of our web site (<http://www.kramerelectronics.com>).

---

---

## Table Of Contents

Section	Name	Page
1	INTRODUCTION	1
1.1	A Word on Video/Audio Switchers	1
1.2	Factors Affecting Quality of Results	1
2	SPECIFICATIONS	2
3	HOW DO I GET STARTED?	2
4	UNPACKING AND CONTENTS	2
4.1	Optional Accessories	3
5	KRAMER VS-4X4YC MATRIX	4
6	SOLUTIONS PROVIDED WITH THE VS-4X4YC	4
7	THE VS-4X4YC CAN BE USED AS	4
8	A QUICK REFERENCE GUIDE	4
9	INSTALLATION	5
9.1	Rack Mounting	5
10	CONNECTING TO VIDEO DEVICES	5
11	CONNECTING TO AUDIO DEVICES	5
12	USING THE VS-4X4YC	6
12.1	Turning On The Matrix	6
12.2	Using The Front Panel Controls	6
12.2.1	Keystrokes	6
12.3	DIP SWITCH Settings	6
13	RS-232 CONTROL	7
13.1	Protocol Used for RS-232 Communication	7
14	TAKING CARE OF YOUR MATRIX	9
15	TROUBLESHOOTING	9
15.1	Power and Indicators	9
15.2	Video Signal	9
15.3	Audio Signal	10
15.4	Control	10
	Limited Warranty	11

## 1. INTRODUCTION

Congratulations on your purchase of this Kramer switcher. Since 1981 Kramer has been dedicated to the development and manufacture of high quality video/audio equipment. The Kramer industrial line has become an integral part of many of the best video/audio production and presentation facilities around the world. In recent years, Kramer has redesigned and upgraded most of the industrial line, making the best even better. Kramer's line of professional video electronics is one of the most versatile and complete available, and is a true leader in terms of quality, workmanship, price/performance ratio and innovation. In addition to the Kramer line of high quality video switchers, such as the one you have just purchased, Kramer also offers a full line of high quality industrial and broadcast distribution amplifiers, processors, interfaces, controllers and computer-related products. Kramer welcomes your inquiries for Kramer equipment or custom-manufactured products, engineering, private labeling and OEM manufacturing per your specifications. This manual includes configuration, operation and option information for the **VS-4x4YC**.

### 1.1 A Word on Video/Audio Switchers

A video/audio switcher switches between several sources (inputs) and one or more acceptors (outputs). A switcher that allows several inputs to be connected to several outputs simultaneously is called a matrix switcher. Switchers may be of the electronic or mechanical type. Most matrices, with many cross points, are of the active electronic type. Vertical interval switching is needed when recording or transmitting a video program involving several video sources, as in live broadcast, to ensure clean, undisturbed picture transitions. Frequently used in video, vertical interval switching ensures that the transition from one video source to another (such as switching between two genlocked cameras) is smooth and without interference. The switching and changeover is done during the blanked vertical interval period, when the transition is hidden. Switchers can be controlled by touch buttons on the front panel or by a PC, via the switcher's built-in communication ports, which may be RS-232 or RS-485/422. Each of these latter options is a way of remotely controlling a video/audio device (switcher, SEG, etc.) using a PC with a serial port, or another device that uses a similar communication protocol. Finally, the wide bandwidth of the video signal permits Kramer switchers to be used in the most demanding of applications. Switchers can be interconnected and cascaded to multiply inputs or connected in parallel to multiply outputs. Several machines may be operated simultaneously via PC control or looped through.

### 1.2 Factors Affecting Quality of Results

- There are many factors affecting the quality of results when signals are transmitted from a source to an acceptor:
- **Connection cables** - Low quality cables are susceptible to interference; they degrade signal quality due to poor matching and cause elevated noise levels. They should therefore be of the best quality.
- **Sockets and connectors of the sources and acceptors** - So often ignored, they should be of highest quality, since "Zero Ohm" connection resistance is the target. Sockets and connectors also must match the required impedance (75ohms in video). Cheap, low quality connectors tend to rust, thus causing breaks in the signal path.
- **Amplifying circuitry** - Must have quality performance when the desired end result is high linearity, low distortion and low noise operation.
- **Distance between sources and acceptors** - Plays a major role in the result. For long distances (over 15 meters) between sources and acceptors, special measures should be taken in order to avoid cable losses. These include using higher quality cables or adding line amplifiers.
- **Interference from neighboring electrical appliances** - These can have an adverse effect on signal quality. Balanced audio lines are less prone to interference, but unbalanced audio and video lines should be installed far from any mains power cables, electric motors, transmitters, etc. even when the cables are shielded.

## 2. SPECIFICATIONS

	<b>VS-4x4YC</b>
<b>Function</b>	4x4 Composite Video - Y/C - Audio Stereo Vertical Interval Matrix
<b>Inputs</b>	4 video, 1Vpp/75 $\Omega$ Composite on BNCs, 4 Y/C - Y=1Vpp/75 $\Omega$ , C=0.3Vpp/ 75 $\Omega$ 4 stereo audio 1Vpp/ 50k $\Omega$ on RCAs.
<b>Outputs</b>	4 video, 1Vpp/75 $\Omega$ Composite on BNCs, 4 Y/C - Y=1Vpp/75 $\Omega$ , C=0.3Vpp/ 75 $\Omega$ 4 stereo audio 1Vpp/ 100 $\Omega$ on RCAs.
<b>Video S/N Ratio</b>	>65 dB
<b>Audio S/N Ratio</b>	>75 dB
<b>Video Bandwidth</b>	>50MHz (-3dB)
<b>Audio Bandwidth</b>	10-100000 Hz (-3dB)
<b>Audio THD</b>	<0.1%
<b>Differential Gain</b>	0.15%
<b>Differential Phase</b>	0.1Deg
<b>Video Crosstalk</b>	-47dB (Luma)
<b>Audio Crosstalk</b>	-53 dB
<b>Switch System</b>	During vertical interval
<b>Switch Time</b>	< 1 frame
<b>Control Type</b>	1 DB-9 connector for RS-232, or touch switches
<b>Weight</b>	2.9 kg. (6.4 lbs.) approx
<b>Dimensions (W x D x H)</b>	19 " x 7 " x 1U; 48 cm x 17.78 x 4.5cm
<b>Power Source</b>	230 VAC 50/60 Hz (115VAC U.S.A), 10.3 VA.

## 3. HOW DO I GET STARTED?

The fastest way to get started is to take your time and do everything right the first time. Taking 15 minutes to read this manual may save you a few hours later. You don't even have to read the whole manual. If the section doesn't apply to you, you don't have to spend your time reading it.

## 4. UNPACKING AND CONTENTS

The items contained in your Kramer VS switcher package are listed below. Please save the original box and packaging materials for possible future transportation and shipment of the video switcher.

- The **VS-4x4YC** Matrix
- AC power cable
- User Manual
- DB-9 to DB-25 or DB-9 to DB-9 Serial (Null Modem) Adapter
- PC-Control Software
- A Concise Directory of KRAMER Products

## 4.1 Optional Accessories

The following accessories, which are available from Kramer, can enhance implementation of your switcher. For information regarding cables and additional accessories, contact your Kramer dealer.

- **BNC "Y" Connector** - Used for looping purposes and splits the incoming signal to connect an additional machine.
- **FC-10D** - (Composite-YC Comb Filter/Transcoder) can be serially connected to the switcher for video format conversion between two popular video formats - composite video and YC (Super-Video). The decoding from composite to Y/C is done digitally using an adaptive comb filter and DSP techniques to minimize dot-crawl and cross-color. A built-in vertical enhancer circuit reduces noise and dot-crawl on the Y signal. In addition, the **FC-10D** provides an independent Y/C to Composite route, for simultaneous bi-directional operation. The Kramer **FC-10D** is very small, and is fed from an external 12VDC supply, thus ideal for fieldwork.
- **FC-4041C** - (Genlock RGB/Component to Composite Video/YC Encoder) can be serially connected to the switcher for video format conversion. It is full broadcast, state-of-the-art, designed for studio and other demanding applications. The **FC-4041C** encodes RGBS or Y, R-Y and B-Y signals to composite video and Super-Video signals. All inputs are looped through with termination switches, allowing parallel connection to other RGBS / Component acceptors. The **FC-4041C** allows the user, via front panel switches, to select whether the Sync is separate or riding on Green. The user can also select whether to convert RGBS or Component (Y, R-Y, B-Y) signals to Composite and Y/C. The outputs are DC coupled and Black-Level clamped.
- **VM-19N** - (RGB Decoder) can be serially connected to the switcher for video format conversion. It is an industrial level decoder, which converts both composite video and super-Video to their RGB components.
- **VM-1411** (Video/Balanced Stereo Audio Distribution Amplifier) can be serially connected between the switcher and the acceptors for video and audio distribution. It is a full broadcast, state-of-the-art machine, designed for studio and other applications. The VM-1411 has two inputs, video and audio, each splitting to 5 outputs. The user may select 2 x 1:5 or 1:10 operation via front panel control switches. Several VM-1411 units may be chained through the looping inputs. Output signals are (user selectable) DC or AC coupled for highest flexibility. Audio outputs are buffered and isolated from each other, allowing Hi-Fi Balanced audio distribution.
- **SP-11** - (Video/Audio Processor) can be serially connected between the video/audio source and the switcher for video and audio control/correction. The machine provides camera control and luminance/white balance correction. The SP-11 is also capable of performing composite to Y/C conversion and bi-directional transcoding. The machine allows full control over the video signal: video gain down to full fade, log or linear definition control, log or linear contrast control, color saturation control, black level control, red, green and blue controls and a screen splitter control for "before-after" comparison. The input switch control is "audio-follow-video".
- **VIDEO TESTER** - A new, unique, patented, indispensable tool for the video professional, the Video Tester is used to test a video path leading to/from an amplifier. By pressing only one touch switch it can trace missing signals, distinguish between good and jittery (VCR sourced) signals, and identify the presence of good signals. Whenever a video signal is missing, because of bad connections, cable breaks or faulty sources, the Video Tester is all you need.

## 5. KRAMER VS-4X4YC MATRIX

This section shows you all of the controls and connections of your switcher. Understanding all of the controls and connections helps you realize its full power. The switcher described in this manual is equipped with an RS-232 connector (for PC control) and the connector wiring is described later on.

The Kramer **VS-4x4YC** is a high performance 4x4 vertical interval matrix switcher for composite and/or s-Video and stereo audio signals. It is a true matrix, allowing the user to route any input to any or all outputs simultaneously. Since the **VS-4x4YC** switches during the vertical interval, transitions are glitch-free when sources share a common reference sync.

The **VS-4x4YC** provides composite video and s-Video connectors allowing it to be used for either format. Mixing formats is possible but composite video sources need to be routed to composite video outputs and, likewise, s-Video sources must be routed to s-Video outputs. It is very important to note that the VS-4x4YC does not perform any signal format conversion.

The **VS-4x4YC** can be controlled by front panel buttons or RS-232 serial commands. For applications requiring remote control via a Windows-based personal computer, K-Switch software is provided at no additional cost. The machine is easy to use, dependable, rugged, and fits in one vertical space of a standard 19" rack.

## 6. SOLUTIONS PROVIDED WITH THE VS-4X4YC

Video recording and playback frequently involve the use of several devices, such as: video cassette recorders, video disc players, cameras, video monitors, video processors, Special Effects Generators, live or satellite feeds or any combination of the above.

Hooking up a complex setup of several devices can result in a maze of wires, which is difficult to manage, cumbersome and possibly dangerous.

The **VS-4x4YC Vertical Interval Switcher** offers an innovative solution to many of the problems arising from switching, editing and signal distribution.

The **VS-4x4YC Vertical Interval Switcher** is simple-to-operate having four Super/Composite video and four stereo audio inputs; and four Super/Composite video and four stereo audio outputs. This allows you to simultaneously connect four sources and four acceptors.

## 7. THE VS-4X4YC CAN BE USED AS:

- a. *Fully buffered and amplified matrix switching system.*
- b. *Four output Super/Composite video and stereo-audio distribution amplifier.*
- c. *Production, routing and program/preview switcher.*

In the **VS-4x4YC**, video signals are switched by means of digital control pulses during the vertical interval and are microprocessor controlled.

## 8. A QUICK REFERENCE GUIDE:

The following description provides information about the controls and display on the front panel of the **VS-4x4YC** and the connections on the back panel.

### Front Panel:

#### ➤ Power

This is the main **VS-4x4YC** Power ON/OFF switch.

#### ➤ Output/input Selectors

There are eight switches on the front panel of the **VS-4x4YC** for input and output selection. These switches electronically control the connection of any of four input sources to any of the four output acceptors. When depressed, as will be explained later, the status read-out will show the connection. Two more switches marked as "ALL" and "OFF" appear on the front panel, their function will be explained later.

The "video sync signals" of input position "1" are used by the **VS-4x4YC** as the basic reference for the timing of the vertical interval switching.

#### **Back Panel:**

##### ➤ **Video Inputs**

A variety of Super-Video / Composite input sources may be used such as videocassette recorders and cameras.

##### ➤ **Audio Inputs**

Up to four stereo-audio input sources can be connected to the **VS-4x4YC**. Audio sources can be the audio section of the video equipment used, or another audio source such as a tape recorder.

##### ➤ **Video Outputs**

Up to four super-Video / composite output acceptors can be hooked up to these connectors. A variety of acceptors may be utilized such as videocassette recorders or video monitors.

##### ➤ **Audio Outputs**

Up to four stereo-audio acceptors can be hooked up to these connectors. Audio acceptors may be the audio section of videocassette recorders, tape recorders or audio amplifiers.

The **VS-4x4YC** may be utilized for die duplication, switching and editing of just stereo-audio sources. In this situation, you would utilize the audio outputs only.

##### ➤ **AC Power Socket**

Connect the appropriate cable to the AC power socket and plug it into a proper AC receptacle. (117 Volts AC, U.S.A.: 230 Volts AC, Europe.)

##### ➤ **RS-232 Connector Socket**

This socket connects via an appropriate adapter, or, as illustrated in the figure at the end of this manual to a PC serial port for RS-232 controlled switching.

## **9. INSTALLATION**

### **9.1 Rack Mounting**

The **VS-4x4YC** may be rack mounted in a standard 19" (1U) EIA rack assembly and includes rack "ears" at the ends of the front panel. The device does not require any specific spacing above or below the unit for ventilation. To rack mount the matrix, simply place the unit's rack ears against the rack rails of the rack, and insert standard screws through each of the four corner holes in the rack ears.

## **10. CONNECTING TO VIDEO DEVICES**

Video sources (such as cameras and VCRs) and output devices (such as monitors, projectors or recorders) may be connected to the switcher through the connectors located on the back of the unit. Please keep in mind that the input signal format must match that of the output signal format. (Example: If the input is composite video, then the output is composite video.) For signal formats that use more than one interconnecting cable between devices, the cables should be of equal length.

## **11. CONNECTING TO AUDIO DEVICES**

Audio sources and output devices (such as amplifiers or recorders) may be connected to the **VS-4x4YC** switcher through the RCA type connectors located on the back of the unit. The **VS-4x4YC** supports unbalanced stereo audio signal types.



## 12. USING the VS-4X4YC

### 12.1 Turning on the Matrix

The matrix should only be turned on after all connections are completed, and all source devices have been turned on. Do not attempt to connect or disconnect any video, audio or control signals to the switcher while it is turned on. Pressing the toggle switch on the far-left front panel to the up position . turns on the matrix. In the up position, the toggle switch glows.

### 12.2 Using the Front Panel Controls

The front panels of Kramer switchers and matrices are designed to be simple to operate, and accomplish the basic function of selecting an input source and output device.

#### 12.2.1 Keystrokes

1. Press the appropriate output key followed by the appropriate input key in order to switch an input to an output.
2. Press "ALL" followed by the appropriate input key to connect an input to all the outputs.
3. Press "ALL" followed by the appropriate output key to connect all the outputs according to the way the selected one is connected.
4. Pressing "OFF" instead of an input key will disconnect an output.
5. Any of the above instructions may be executed by pressing the two keys simultaneously rather than pressing them consecutively. When using two keys, the display will flash the appropriate output(s) while waiting for the second keystroke (if the second key is not pressed within a period of one minute, the pending operation is canceled).
6. Pressing input keys 1, 2 and 3 simultaneously will reset the machine.

### 12.3 DIP SWITCH Settings

1. If only one machine is used in the system, it must be set up as the master.
2. If more than one machine is used, setup one as file master, and the others as slaves, each slave having its own unique "slave number" - except for file case where machines are hooked up in parallel (see below).
3. The **VS-4x4YC** only reads the dip-switch setting on initialization, so if the switch settings are changed while the machine is on, the machine must be turned off and then on again, (or input keys 1, 2 and 3 pressed together) in order that the new switch settings are realized.
4. If several machines are to be used "in parallel" to switch together, e.g. when using 4 machines together to make a 4X4 RGBS switcher, then all the parallel machines should be set up to have the same slave number.
5. If the **VS-4x4YC** is to be used as a VIS-4x4, then dip-switch 2 should be OFF. Note that when simulating a VIS-4x4, the "OFF" key is not relevant, and is ignored.
6. The dip-switch settings are as follows:

	1	2*	3	4	5	6	7	8
<b>UNIT 1 (master)</b>	ON	ON	ON	OFF	OFF	OFF	OFF	OFF
<b>UNIT 2 (slave 1)</b>	OFF	ON	OFF	OFF	OFF	OFF	OFF	ON
<b>UNIT 3 (slave 2)</b>	OFF	ON	OFF	OFF	OFF	OFF	ON	OFF
<b>UNIT 4 (slave 3)</b>	OFF	ON	OFF	OFF	OFF	OFF	ON	ON
<b>UNIT 5 (slave 4)</b>	OFF	ON	OFF	OFF	OFF	ON	OFF	OFF
<b>UNIT 6 (slave 5)</b>	OFF	ON	OFF	OFF	OFF	ON	OFF	ON
<b>UNIT 7 (slave 6)</b>	OFF	ON	OFF	OFF	OFF	ON	ON	OFF
<b>UNIT 8 (slave 7)</b>	OFF	ON	OFF	OFF	OFF	ON	ON	ON*

\*See note 5 above.

### 13. RS-232 CONTROL

1. To control the **VS-4x4YC** using RS-232, connect the "9 pin to 9 pin adapter" (provided with the machine) to the 9 pin serial port of the PC. Use a flat cable to connect from the 9 pin of the **VS-4x4YC** to the 9 pin of the adapter. (The adapter is a null-modem plug and 9-pin to 9-pin converter - see diagram below).
2. The DOS based PC program may be downloaded from the Internet at the Kramer Website / Technical support section. The website address is: [www.kramerelectronics.com](http://www.kramerelectronics.com) .The program allows control and monitoring of the **VS-4x4YC** via an IBM compatible PC. Please read the readme.txt file before installation.
3. The Windows™ based program – the K-SWITCH - that comes with the machine is fully described in the K-SWITCH manual. Please follow the instructions carefully. If needed, you may download the latest version of the program from the website above.
4. The protocol used for controlling the **VS-4x4YC** may be found in the appendix.
5. If several machines are used (in a master / slave setup, or if they are connected in parallel to switch together), then the machines should be daisy-chained via their 9 pin interface sockets using a flat-cable.

#### 13.1 Protocol used for RS-232 Communication

Communication with the **VS-4x4YC** is defined using 2 bytes of information. Data transfer is at 9600 baud, with no parity, 8 data bits and one stop bit.

<b>MSB</b>	1st byte	<b>LSB</b>	<b>MSB</b>	2nd byte	<b>LSB</b>
<b>N7N6 N5 N4 N3 N2 N1 N0</b>			<b>N15N14N13N12N11N10N9N8</b>		

Where N7-0 (continue bit).

N6N5N4N3 = 1000 (transmitted by the machine to the PC, but not necessary when transmitting to the machine).

N2N1N0 is the binary value of the machine being addressed (or of the machine sending its data) minus one, e.g., N2N1N0=000 to address machine #1 (the master); N2N1N0=101 to address machine #6.

N15 = 1 (continue bit).

N14 = 0 for all communication to and from the PC.

N13 is high if N12N11N10N9N8 is an op code. The op codes are defined as:

N12N11N10N9N8 = 00001 instructs a machine to send its present status.

N12N11N10N9N8 = 00010 success code (change in status was performed).

N12N11N10N9N8 = 00011 non-success (change in status not was performed).

N.B.: - Success/non-success codes, (according to the validity of the request), are returned from the machine, which was instructed to change its status.

N13 is low when a change in the machine's status is made (via the front panel switches), or when a change in the status is requested (by R5-232). N13 is also low when the machine sends its present status (when answering to op code 00001, and when the machine is turned on). When N13 is low, the value of N12N11N10N9N8 corresponds to the status (or the required change in status) of the machine, as described below:

	OUT1	OUT2	OUT3	OUT4	ALL
From Inputs	1	2	3	4	21
From Input2	5	6	7	8	22
From Input 3	9	3 0	11	12	23
From Input 4	13	14	15	16	24
OFF	17	18	19	20	25

For example, to connect input 4 to output 2, N12N11N10N9N8 should be set up as 01110 (=14). To connect input 3 to all the outputs, N12N11N10N9N8 = 10111(=23). To disconnect output 1, N12N11N10N9N8 = 10010 (=17). Similarly, if the front panel switches were pressed to connect input 2 to output 3, then N12N11N10N9N8 would be transmitted as 00111 (=7).

# RS-232 Null Modem Connection

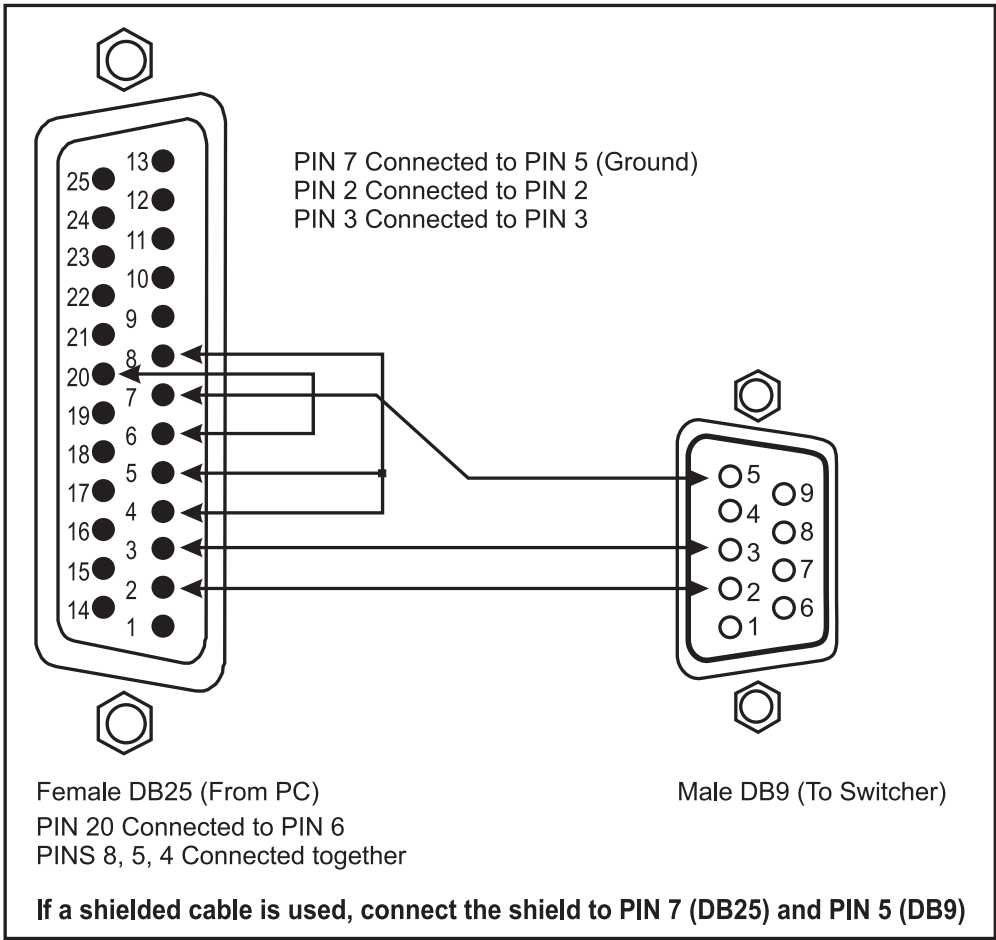
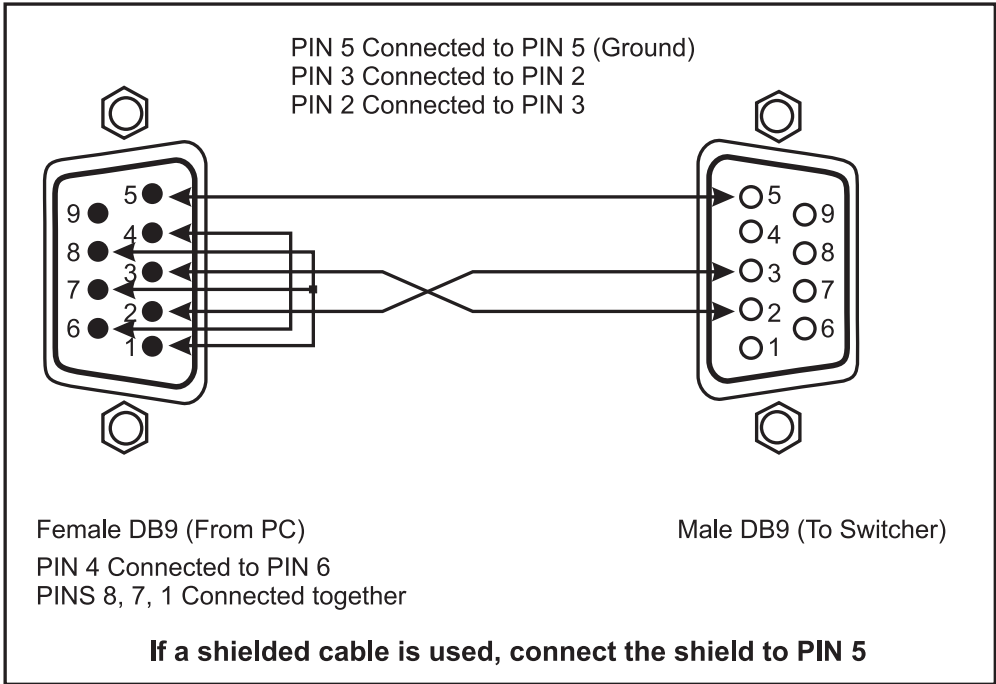

## 14. TAKING CARE OF YOUR MATRIX

Do not locate your matrix in an environment where it is susceptible to dust or moisture. Both of these may damage the electronics, and cause erratic operation or failure. Do not locate your switcher where temperature and humidity may be excessive. Doing so may also damage the electronics, and cause erratic operation or failure of your switcher. Do not clean your switcher with abrasives or strong cleaners. Doing so may remove or damage the finish, or may allow moisture to build up. Take care not to allow dust or particles to build up inside unused or open connectors.

## 15. TROUBLESHOOTING

### NOTES

1. *Please note that if the output signal is disturbed or interrupted by very strong external electromagnetic interference, it should return and stabilize when such interference ends. If not, turn the power switch off and on again to reset the machine.*
2. *If the following recommended actions still do not result in satisfactory operation, please consult your KRAMER Dealer.*

### 15.1 Power and Indicators

Problem	Remedy
No power	<ol style="list-style-type: none"> <li>1. Confirm that the rocker switch is in the "ON" position, and that the lamp is illuminated.</li> <li>2. Confirm that power connections are secured at the amplifier and at the receptacle. Make sure the receptacle is active, outputting the proper mains voltage.</li> <li>3. If there is still no power, check the fuse. Remove power cord from the AC outlet and from the machine and then, using a flat head screwdriver, remove the fuse holder located directly below the power connector. Confirm that the fuse is good by looking at the wire connected to the ends of the fuse. If the wire is broken, replace the fuse with another.</li> </ol>

### 15.2 Video Signal

Problem	Remedy
No video at the output device, regardless of input selected.	<ol style="list-style-type: none"> <li>1. Confirm that your sources and output device are powered on and connected properly. Video signals connected to the input of your switcher should be of an identical signal format at the output of your source. Video signals at the output of your switcher should be of an identical signal format as at the input of your display or recorder.</li> <li>2. Confirm that any other switchers in the signal path have the proper input and/or output selected.</li> <li>3. Use the Video Tester to test the video path leading to/from your switcher (see section 4.1 " Video Tester")</li> </ol>
Video level is too high or too dim.	<ol style="list-style-type: none"> <li>1. Verify that the video line is well matched through 75ohm impedance, otherwise it results in a video level that is too high or too dim when looping is performed and the termination switches are not in proper position.</li> <li>2. Confirm that the connecting cables are of high quality, properly built and terminated with 75ohm BNC connectors. Check level controls located on your source input device or output display or recorder.</li> </ol>

Problem	Remedy
<p>Noise bars “roll” up or down in the output image</p> <p>or:</p> <p>Low frequency hum in the output signal</p>	<p>Hum bars (ground loop) are caused by a difference in the ground potential of any two or more devices connected to your signal path. This difference is compensated by passing that voltage difference through any available interconnection, including your video cables.</p> <p style="text-align: center;"><b>WARNING!</b> <i>Do not disconnect the ground from any piece of video equipment in your signal path!</i></p> <p>Check the following to remove hum bars:</p> <ol style="list-style-type: none"> <li>1. Confirm that all interconnected equipment is connected to the same phase of power, if possible.</li> <li>2. Remove equipment connected to that phase that may introduce noise, such as motors, generators, etc.</li> <li>3. Disconnect all interconnect cables and reconnect them one at a time until the ground loop reappears. Disconnect the affected cable and replace, or insert an isolation transformer in the signal path.</li> </ol>

### 15.3 Audio Signal

Problem	Remedy
<p>No audio at the output device, regardless of input selected</p>	<ol style="list-style-type: none"> <li>1. Confirm that your sources and output device are powered on and connected properly. Audio signals connected to the input of your switcher should be properly wired to the output of your source. Audio signals connected to output of your switcher should be properly wired to the input of your switcher or recorder.</li> <li>2. Confirm that any other switchers in the signal path have the proper input and/or output selected.</li> </ol>
<p>Audio level is too low</p>	<ol style="list-style-type: none"> <li>1. Confirm that the connecting cables are of high quality and properly built. Take special care in noting the wiring configuration of balanced to unbalanced cables.</li> <li>2. Check level controls located on your source input device or output display or recorder.</li> </ol>

### 15.4 Control

Problem	Remedy
<p>No control of switcher from PC software</p>	<ol style="list-style-type: none"> <li>1. Confirm the wiring of the connecting cable. Cable length should not exceed 25 feet.</li> <li>2. Confirm that all DIP switches on the switcher have been set properly. Keep in mind that if you are only controlling one switcher on a specific port, that switcher must be assigned the ID of “1”.</li> <li>3. Confirm that the baud rate of your computer COM port is set to the same as that of your switcher (9600-Baud). Confirm that the proper COM port is selected in the control software.</li> <li>4. Confirm that bi-directional communication is enabled on all switchers. With custom software, do not send multiple commands at the same time. The switcher must complete one command before receiving another.</li> </ol>



---

## **LIMITED WARRANTY**

Kramer Electronics (hereafter Kramer) warrants this product free from defects in material and workmanship under the following terms.

### **HOW LONG IS THE WARRANTY**

Labor and parts are warranted for three years from the date of the first customer purchase.

### **WHO IS PROTECTED**

Only the first purchase customer may enforce this warranty.

### **WHAT IS COVERED AND WHAT IS NOT COVERED**

Except as below, this warranty covers all defects in material or workmanship in this product. The following are not covered by the warranty:

- 1) Any product which is not distributed by Kramer, or which is not purchased from an authorized Kramer dealer. If you are uncertain as to whether a dealer is authorized, please contact Kramer at one of the agents listed in the web site [www.kramerelectronics.com](http://www.kramerelectronics.com).
- 2) Any product, on which the serial number has been defaced, modified or removed.
- 3) Damage, deterioration or malfunction resulting from:
  - a) Accident, misuse, abuse, neglect, fire, water, lightning or other acts of nature.
  - b) Product modification, or failure to follow instructions supplied with the product.
  - c) Repair or attempted repair by anyone not authorized by Kramer.
  - d) Any shipment of the product (claims must be presented to the carrier).
  - e) Removal or installation of the product.
  - f) Any other cause, which does not relate to a product defect.
  - g) Cartons, equipment enclosures, cables or accessories used in conjunction with the product.

### **WHAT WE WILL PAY FOR AND WHAT WE WILL NOT PAY FOR**

We will pay labor and material expenses for covered items. We will not pay for the following:

- 1) Removal or installations charges.
- 2) Costs of initial technical adjustments (set-up), including adjustment of user controls or programming. These costs are the responsibility of the Kramer dealer from whom the product was purchased.
- 3) Shipping charges.

### **HOW YOU CAN GET WARRANTY SERVICE**

- 1) To obtain service on you product, you must take or ship it prepaid to any authorized Kramer service center.
- 2) Whenever warranty service is required, the original dated invoice (or a copy) must be presented as proof of warranty coverage, and should be included in any shipment of the product. Please also include in any mailing a contact name, company, address, and a description of the problem(s).
- 3) For the name of the nearest Kramer authorized service center, consult your authorized dealer.

## LIMITATION OF IMPLIED WARRANTIES

All implied warranties, including warranties of merchantability and fitness for a particular purpose, are limited in duration to the length of this warranty.

## EXCLUSION OF DAMAGES

Kramer's liability for any defective products is limited to the repair or replacement of the product at our option. Kramer shall not be liable for:

- 1) Damage to other property caused by defects in this product, damages based upon inconvenience, loss of use of the product, loss of time, commercial loss; or
- 2) Any other damages, whether incidental, consequential or otherwise. Some countries may not allow limitations on how long an implied warranty lasts and/or do not allow the exclusion or limitation of incidental or consequential damages, so the above limitations and exclusions may not apply to you.

This warranty gives you specific legal rights, and you may also have other rights, which vary from place to place.

**NOTE:** All products returned to Kramer for service must have prior approval. This may be obtained from your dealer.

---

## NOTICE

This equipment has been tested to determine compliance with the requirements of:

- EN-50081:** "Electromagnetic compatibility (EMC);  
generic emission standard.  
Part 1: Residential, commercial and light industry"
- EN-50082:** "Electromagnetic compatibility (EMC) generic immunity standard. Part 1:  
Residential, commercial and light industry environment".
- CFR-47** FCC Rules and Regulations:  
Part 15- "Radio frequency devices:  
Subpart B- Unintentional radiators"

## CAUTION!

- ☒ Servicing the machines can only be done by an authorized Kramer technician. Any user who makes changes or modifications to the unit without the expressed approval of the manufacturer will void user authority to operate the equipment.
- ☒ Use the supplied DC power supply to feed power to the machine.
- ☒ Please use recommended interconnect cables to connect the machine to other components.

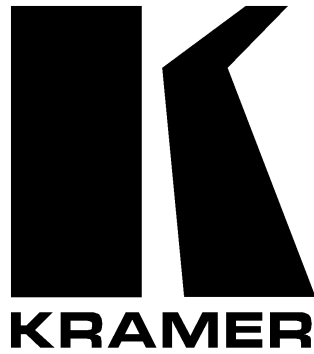

**The list of Kramer distributors appears on our web site:  
[www.kramerelectronics.com](http://www.kramerelectronics.com)  
From the web site it is also possible to e-mail factory headquarters.  
We welcome your questions, comments and feedback.**

---

**KRAMER ELECTRONICS, LTD.**

3 Am VeOlamo Street. Jerusalem 95463, Israel Tel: (972-2)-654-4000. Fax: (972-2)-653-5369  
E-mail: [kramere@netvision.net.il](mailto:kramere@netvision.net.il)