

JVC[®]

The Perfect Experience / —

SYSTEMS &
PORTABLE AUDIO
2005



TOWER of POWER

HX SERIES

TWIN GIGA-TUBE

Twin GIGA-TUBE
with Staggered Bass-Reflex Technologies

**MORE POWER,
MORE EXCITEMENT**

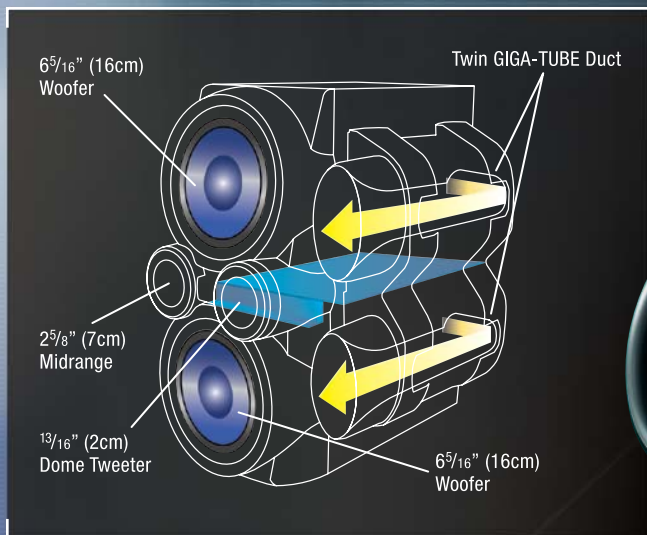

The new speakers deliver an intensified listening experience with even deeper bass. The unit features twin GIGA-TUBE ducts and twin woofers each housed in a separate chamber differing in size and structure. This design effectively staggers the tuning frequencies of both the twin-woofer and the bass-reflex port broadening the low-frequency sound range.



Throbbing power. Deeper bass with stronger beats. Endless tracks and movies from a 5-disc changer. The compact and stylish HX-D7 offers all this with a wide range of playable formats including DVD-Audio/Video. With the amazing features of the HX-D7 and HX-C6 Compact Component Systems, discover a new world of exciting entertainment.

Rhythmfix

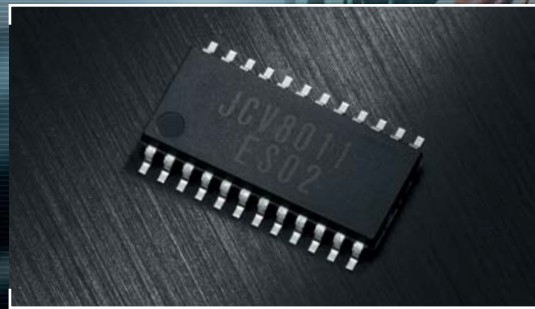

One touch of the RHYTHMAX button boosts your excitement — even at low sound levels! This smart, JVC-exclusive technology enables the system to detect and boost a song's rhythmical tones, like the beats from bass percussion. RHYTHMAX intensifies your listening experience even when the song has no "beats", such as with classical music. The "Loudness Function" automatically builds up the bass tones recorded at low levels, which are typically inaudible at low volumes.

**MORE VERSATILITY,
— THE HX SERIES**



DVD AUDIO/VIDEO

DVD-Audio/Video Playback

The HX-D7 puts you in control of more dynamic, sensitive, and crisper sound than that of any ordinary CD player! DVD-Audio's superior specifications and multi-channel compatibility will transport you into another dimension of the listening experience. Of course, the unit also plays DVD-Video — allowing you to enjoy movies with enhanced dynamism and excitement.

5-DVD PLAY & EXCHANGE

Play and Exchange 5-DVD Tray Changer

Load up to five discs to scan through an expanded number of movies, albums, and tracks with ease. This also enables you to change discs without interrupting your currently playing audio/video content.



Front AUX Input

An auxiliary input is conveniently located on the front panel. Enjoy sound from external sources, such as digital audio players.

Front USB Input

A USB input located on the front panel of your Compact Component System allows for an easy connection with your PC. You can now listen to the audio content stored on your PC's hard drive through the sound quality of your JVC Compact Component System, and listen to your music the way it was meant to be heard.



HX Series

"Tower of Power" Rocks... and Rocks You

TWIN
GIGA-TUBE

520W
TOTAL POWER



HX-D7

DVD Compact Component System

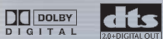

Digital Direct
Progressive Scan

EXPRESS
PLAY START

CD-R/RW
PLAYBACK

MP3
PLAYBACK

JPEG
PLAYBACK



5.1
SPEAKERS

USB
Terminal

AV COMPU LINK

520W high-power Component System with 5-DVD-Audio/Video changer — featuring Twin GIGA-TUBE Low-Pass Advanced Labyrinth Aero TUBE Subwoofers and USB audio input

- Twin GIGA-TUBE Low-Pass Advanced Labyrinth Aero TUBE Subwoofers deliver a more dynamic and intensified sound
- 5-DVD Tray Changer with Play & Exchange System — discs not in play can be replaced even during playback
- Dolby Digital/DTS Decoders (2ch) Built-in
- USB Input for easy PC connection
- Front AUX Input for enjoying songs from external devices with ease
- RHYTHMAX — intensifies the sound by amplifying signals comprising "rhythm" of a tune
- Digital Direct Progressive Scan Output
- 3D-PHONIC (Action/Drama/Theater) for virtual surround sound
- Bi-Amp Configuration — separately drives the main speakers and subwoofers for lower distortion
- Live Surround (3 Modes): DANCE CLUB/HALL/STADIUM
- Sound Modes: ROCK/POP/CLASSIC
- Extended Super Bass
- Eco Mode
- Power Output: 520 Total Watts, Subwoofer: 180 watts per channel; Main Speaker: 80 watts per channel
- Sources: DVD-Audio/Video, DVD-R/RW (Video Format), CD, CD-R/RW, SVCD/VCD, MP3/JPEG (CD-R/RW), Tuner, USB Input
- Staggered 4-Way Bass-Reflex: 6⁵/₁₆" (16cm) Cone Woofer, 2⁵/₈" (7cm) Cone Midrange, 1³/₁₆" (2cm) Dome Tweeter, and 6⁵/₁₆" (16cm) Cone Subwoofer
- 192kHz/24-bit Audio D/A Converter
- 99-Track Program Play
- Magnetically Shielded

Notice: It should be noted that it may be unlawful to re-record pre-recorded tapes, records, or discs without the consent of the owner of copyright in the sound or video recording, broadcast or cable program and in any literary, dramatic, musical, or artistic work embodied therein.

"Dolby," the double-D symbol and "Dolby Digital" are trademarks of Dolby Laboratories Licensing Corporation. "DTS" is a trademark of Digital Theater Systems, Inc.



**TWIN
GIGA-TUBE**
500W
TOTAL POWER



HX-C6

Compact Component System



5-CD Changer Component System with 500W high power — featuring Twin GIGA-TUBE Low-Pass Advanced Labyrinth Aero TUBE Subwoofers, RHYTHMAX, and MP3 playback

- Twin GIGA-TUBE Low-Pass Advanced Labyrinth Aero TUBE Subwoofers deliver a more dynamic and intensified sound
- 5-CD Tray Changer with Play & Exchange System — discs not in play can be replaced even during playback
- USB Input for easy PC connection
- Front AUX Input for enjoying songs from external devices with ease
- RHYTHMAX — intensifies the sound by amplifying signals comprising “rhythm” of a tune
- Bi-Amp Configuration — separately drives the main speakers and subwoofers for lower distortion
- Live Surround (3 Modes): DANCE CLUB/HALL/STADIUM
- Sound Modes: ROCK/POP/CLASSIC
- Extended Super Bass
- Eco Mode
- Power Output: 500 Total Watts, Subwoofer: 170 watts per channel; Main Speaker: 80 watts per channel
- Sources: CD, CD-R/RW, MP3 (CD-R/RW), Tuner, USB Input
- Staggered 4-Way Bass-Reflex: 6⁵/₁₆” (16cm) Cone Woofer, 2⁵/₈” (7cm) Cone Midrange, 1³/₁₆” (2cm) Dome Tweeter, and 6⁵/₁₆” (16cm) Cone Subwoofer
- 1-bit Dual D/A Converter
- 32-Track Program Play

MX Series

Geared for Maximum Power and Intensity

Ear-Blasting, Mind-Blowing Sound

The MX Series is all about stylish looks, a compact body, supreme sound, and endless excitement. Massive power from large-size speakers and astounding bass from matching subwoofers deliver a musical impact boosted with even stronger beats via the RHYTHMAX button.

GIGA-TUBE

Low-pass Advanced Labyrinth Aero TUBE Subwoofer (MX-GC5)

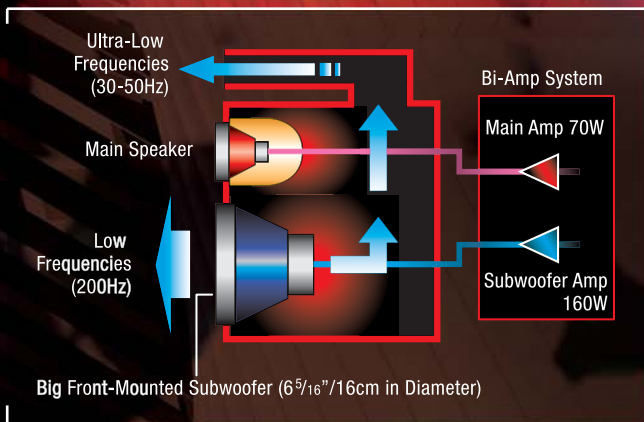

The Multi-Amplifier System comes with four separate high-power amps to individually drive the main speakers and subwoofers with minimal distortion. A large-diameter subwoofer and an optimally-tuned duct give you substantial bass and rich, full mids.



GIGA-TUBE

460W
TOTAL POWER



MX-GC5

Compact Component System

Rhythmfix

CD-R/RW
PLAYBACK

MP3
PLAYBACK



3-CD Changer Component System with GIGA-TUBE Low-Pass Advanced Labyrinth Aero TUBE Subwoofers, RHYTHMAX, and 460W high power

- GIGA-TUBE Low-Pass Advanced Labyrinth Aero TUBE Subwoofers — Heart-pounding bass and rich, full mids
- 3-CD Carousel Changer with Play & Exchange System — discs not in play can be replaced even during playback
- USB Input for easy PC connection
- Front AUX Input for enjoying songs from external devices with ease
- RHYTHMAX — intensifies the sound by amplifying signals comprising “rhythm” of a tune
- Bi-Amp Configuration — separately drives the main speakers and subwoofers for lower distortion
- Live Surround (3 Modes): DANCE CLUB/HALL/STADIUM
- Sound Modes: ROCK/POP/CLASSIC
- Extended Super Bass
- Eco Mode — for saving power consumption
- Power Output: 460 Total Watts, Subwoofer: 160 watts per channel; Main Speaker: 70 watts per channel
- Sources: CD, CD-R/RW, MP3 (CD-R/RW), Tuner, USB Input
- 3-Way Bass-Reflex: 4³/₄” (12cm) Cone Woofer, 2” (5cm) Cone Tweeter, and 6⁵/₁₆” (16cm) Cone Subwoofer
- 1-bit Dual D/A Converter
- 32-Track Program Play

360W
TOTAL POWER



MX-KC4

Compact Component System

Rhythmfx

CD-R/RW
PLAYBACK

MP3
PLAYBACK

High-power 3-CD Changer Component System featuring intensified sound by RHYTHMAX

- 3-CD Carousel Changer with Play & Exchange System — discs not in play can be replaced even during playback
- Front AUX Input for enjoying songs from external devices with ease
- MP3 Text Display
- RHYTHMAX — intensifies the sound by amplifying signals comprising “rhythm” of a tune
- Sound Modes: ROCK/POP/CLASSIC
- Power Output: 360 Total Watts, 180 watts per channel
- Sources: CD, CD-R/RW, MP3 (CD-R/RW), Tuner, Cassette
- 3-Way Bass-Reflex: 6⁵/₁₆” (16cm) Cone Woofer, 2” (5cm) Cone Midrange, and 1³/₁₆” (2cm) Dome Tweeter
- 1-bit Dual D/A Converter
- 32-Track Program Play
- Full-Logic Control Cassette Deck

Experience LCD from JVC

The perfect match for your JVC Gigatube system with DVD might just be a JVC high definition LCD monitor. Just like your audio system, JVC LCD monitors offer high performance in a sleek, space saving design.



JVC 40" LCD: LT-40X776

A new flat panel LCD display is equal parts performance and design. You'll marvel at the stunning picture quality provided by the high definition panels with up to full 1920 x 1080 resolution, meaning they can display every pixel, or picture element, found in a full high definition

signal. Most new models are powered by the next generation JVC exclusive D.I.S.T. (Digital Image Scaling Technology), which uses JVC's new 32 bit GENESSA chip. This single chip provides optimum scaling of any input signal to your LCD display. The picture fits perfectly, with the highest possible resolution. Also part of D.I.S.T. are 5-Point Color Management and Dynamic Gamma Control. The new 5-Point Color Management insures perfect color, even with skin tones, while Dynamic Gamma makes sure the grayscale is correct and that detail is maintained in the darker/shadow portions of the picture.

Screen picture is simulated.

There are also a variety of other noise reduction and picture enhancement technologies. Whether your source is progressive scan DVD or true high definition, you will be impressed!

JVC provides the performance you need with the aesthetics you want. For both wall mount and traditional table top applications, you'll admire the arc shape design elements and cool blue illumination which complement your JVC Gigatube system.

Ease of operation is also paramount with JVC. The exclusive Smart Input simplifies connection to other components, while the EZ Fill makes it simple to adjust any picture to fill the full screen, eliminating most letterbox bars if you choose.

All new JVC widescreen LCD displays are HD ready and ATSC HD Tuners are included on our new premium 26" & 32" sizes. ATSC tuners are standard on our new 37" & 40" displays.



5 Point Color Management at Work

- POINT 1 - Green
- POINT 2 - Yellow
- POINT 3 - Red
- POINT 4 - Blue
- POINT 5 - Flesh

CD Portable Systems

Bring the Beats Wherever You Go

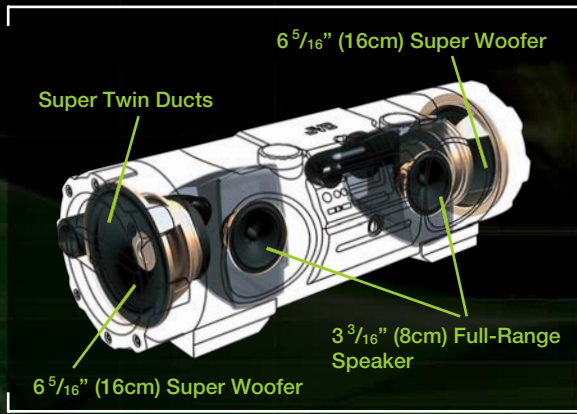

Twin 6 ⁵/₁₆" (16cm) Super Woofers and Super Twin Ducts for Rock-Bottom Bass

A pair of extra-large 6 ⁵/₁₆" (16cm) Super Woofers gives you powerful, deep bass sound in combination with a number of JVC technologies. Units are mounted back-to-back to cancel out vibrations, while the Super Twin Ducts deliver crisp, extended bass sound. A weight ring coupled to the woofer helps extend response down to under 100Hz. A 6-layer voice coil shifts down the lowest resonance frequency and increases driving power. The woofer units also feature foamed rubber surround to achieve both high linearity and low distortion.



Microphone/Guitar Input with Level Control



kaboom!



Shoulder Strap



RV-NB1

Powered Woofer CD System

CD-R/RW
PLAYBACK

MP3
PLAYBACK

Powerful CD/MP3 Component System with a Built-in Guitar Amp — featuring Twin Super Woofers and Super Twin Ducts for massive sound with deep bass

- Twin 6 ⁵/₁₆" (16cm) Super Woofers with Level Controls • Super Twin Ducts • Mic/Guitar Input with Level Control • Built-in Guitar Amp • 4-Amp Configuration • Digital Tuner with 15 AM and 30 FM Preset Stations • Compu Play — turn on the system and automatically start the radio, disc player, or cassette deck with a single touch of a button • MP3 Text (Track Titles and ID3 Tags) displayed on LCD in two lines • 4 Preset EQ Patterns • Program (50 Tracks)/Random/Repeat Play • CD Synchro-Start Recording • Full-Function Remote Control • Remote Control Case on Shoulder Strap Provided

- Power Output: Full Range: 6 watts per channel; Super Woofer: 20 watts per channel • Sources: CD, CD-R/RW, MP3 (CD-R/RW), Tuner, Cassette • 3 ³/₁₆" (8cm) Full-Range Speakers • Back-Illuminated LCD (Blue) • 1-bit D/A Converter

PC-X290

CD Portable Component System

CD-R/RW
PLAYBACK

HBS

CD Portable Component System featuring dynamic sound from Twin Woofers, Twin Tweeters, and Hyper-Bass Sound System

- Digital Tuner with 10 AM and 10 FM Preset Stations • Hyper-Bass Sound System • 5 Preset EQ Patterns
- Program (20 Tracks)/Random/Repeat Play • Intro Scan • CD Synchro-Start Recording • Remote Control
- Power Output: 5 watts per channel • Sources: CD, CD-R/RW, Tuner, Cassette • 3¹⁵/₁₆" (10cm) Woofer x 2, 2" (5cm) Tweeter x 2
- Back-Illuminated LCD (Amber) • 1-bit D/A Converter

RC-EX36

CD Portable System

CD-R/RW
PLAYBACK

MP3
PLAYBACK

HBS

Stylish CD Portable System featuring MP3 Playback and AM/FM Digital Tuner

- Digital Tuner with 10 AM and 20 FM Preset Stations
- MP3 Text (Track Titles and ID3 Tags) displayed on LCD
- Hyper-Bass Sound System • 5 Preset EQ Patterns
- Program (40 Tracks)/Random/Repeat Play • Intro Scan (CD Only) • CD Synchro-Start Recording • Remote Control
- Power Output: 2 watts per channel • Sources: CD, CD-R/RW, MP3 (CD-R/RW), Tuner, Cassette • 3⁹/₁₆" (9cm) Full-Range Speakers
- Back-Illuminated LCD (Blue) • 1-bit D/A Converter

RC-EX26

CD Portable System

CD-R/RW
PLAYBACK

HBS

CD Portable System with AM/FM Digital Tuner, Equalizer, and Remote Control

- Digital Tuner with 10 AM and 10 FM Preset Stations
- Hyper-Bass Sound System • 5 Preset EQ Patterns
- Program (20 Tracks)/Random/Repeat Play • Intro Scan (CD Only) • CD Synchro-Start Recording • Remote Control
- Power Output: 2 watts per channel • Sources: CD, CD-R/RW, Tuner, Cassette • 3⁹/₁₆" (9cm) Full-Range Speakers • Back-Illuminated LCD (Amber) • 1-bit D/A Converter

RC-EX16

CD Portable System

CD-R/RW
PLAYBACK

HBS

Stylish CD Portable System with Cassette Deck, AM/FM Tuner, and Remote Control

- Hyper-Bass Sound System for dynamic bass at the touch of a button • Program (20 Tracks)/Random/Repeat Play
- CD Synchro-Start Recording • Remote Control
- Power Output: 2 watts per channel • Sources: CD, CD-R/RW, Tuner, Cassette • 3⁹/₁₆" (9cm) Full-Range Speakers • 1-bit D/A Converter

Digital Audio Player

Stylish Digital Sound — Wear It

Clip-on “Digital Player” Headphones

Enjoy MP3/WMA sound while on the go with the player built directly into clip-style headphones. It's a smart 2-in-1 solution for enhanced listening pleasure.

MP3/WMA/WMA-DRM* Compatibility

The XA-A50CL stores and plays MP3, WMA, and WMA-DRM music files. The unit's 128MB Flash Memory can hold nearly 30 files of MP3 or 60 files of WMA content. Enjoy digital music with near-CD-quality sound anytime, anywhere.

* Windows Media™ DRM - Microsoft® Windows Media™ Digital Rights Management

USB 1.1 Connection

The digital audio player comes with USB 1.1 input for easy “drag and drop” music file transfer from PC. The unit also permits USB 2.0 connection.

Intuitive Control with Voice Guidance

The XA-A50CL is a comfortable-to-wear, ear-clip digital audio player that permits intuitive, “no-look” control. The unit also features “Voice Guidance” function — which tells you what operation is being performed — for error-free setup and unit control.

4 SRS Modes and 5 Preset EQ Modes

The JVC digital audio player lets you customize the sound with 9 preset modes. The unit provides 4 SRS modes, including SRS TruBass, WOW MODE 1, WOW MODE 2, and WOW MODE 3. The unit also offers 5 preset EQ modes — FLAT, CLASSIC, ROCK, POP, and LIVE.

A “Wear and Go” Player

The XA-A50CL takes “portable” to a new level. The compact digital audio player is a set of headphones with a built-in player and comfortable clip-on design — another smart solution from JVC.





XA-A50CL

Digital Audio Player

WMA
PLAYBACK

MP3
PLAYBACK

JVC's first Headphone-type Digital Audio Player featuring a stylish design and extremely light weight

- Built-in 128MB Flash Memory that stores up to approximately 30 MP3 files or 60 WMA files • 20-hour continuous playback with one AAA alkaline battery • Voice Guidance Function for assisting setup and playback operations • A wide range of surround sound modes (SRS WOW) • Supports Windows Media™ Player 9
- Compatible audio playback formats: MP3, WMA, WMA-DRM (copyright protected) • USB 1.1 Connection (USB 2.0 Compatible) • System Requirements: Windows® 98SE or later

Experience Mobile Entertainment from JVC

JVC high power home audio systems are perfect when you crave bass and want to pump up the volume. That same experience is also available in your car with our new line of mobile entertainment products.

The 2005 JVC Mobile Entertainment lineup offers more choices than ever in both audio and video. High Power MOS-FET and Hybrid Feedback Digital Amplifiers give the sound quality you demand. Advanced Digital Signal Processing lets you dial in the sound to your exact tastes with Parametric Equalization, Selectable High Pass and Low Pass Filters, Time Alignment and more.

A full range of speaker systems and amplifiers can take you from mild to wild in any vehicle. Whether you are looking for a single pair of speakers, or separate component speakers with advanced crossover networks and high power subwoofers, JVC has you covered.

Select JVC in-dash receivers include the latest multi-zone DVD technology and built-in 3" or 7" screens. Multi-zone means the passengers up front can enjoy their favorite music through the vehicle's speaker system, while the passengers in the back watch DVD video and enjoy that sound on wireless headphones. Both headrest and overhead monitors are available in a variety of sizes and configurations.

JVC is ready for the newest digital audio formats. "Giga MP3" makes it possible to store over 1,000 of your favorite songs on

a single DVD in either MP3 or WMA format. Or, store music on an SD card and play it back on select JVC in-dash receivers with a built in SD card slot.

Most JVC in-dash receivers are Sirius

Ready, which assures easy connection to a matching Sirius tuner and convenient control via the receiver's front panel. All Sirius music channels are 100% commercial free, and Sirius has the widest variety of sports on satellite radio, including full NFL coverage, as well as top college sports. In total, Sirius offers over 120 channels of music, sports, news and entertainment, making it easy to find just what you are looking for.

JVC Mobile is the way to go, in style!

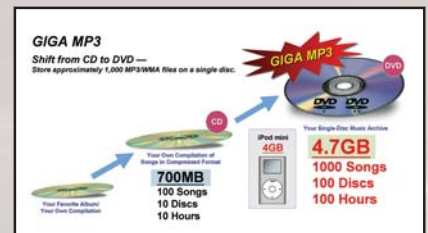

Giga MP3



KD-AVX1

Portable CD Players

Spin the Disc, and the Disc Spins You



Grip Band for Active Listeners

The Grip Band lets you jog, in-line skate, or skateboard with your player firmly affixed to your hand. There is no need to take a break from the action with JVC's intuitive control key layout — ease of operation is at your fingertips.



XL-PR70

Portable Tuner CD Player

Portable CD/MP3/WMA Player with 40-Sec. (CD), 100-Sec. (MP3) Anti-Shock Memory and Built-in FM Tuner

ANTI-SHOCK PROTECTION
EX CD-R/RW
PLAYBACK

WMA
PLAYBACK **MP3**
PLAYBACK

HBS Grip Band

- Digital Tuner with 20 FM Preset Stations
- MP3 Text (Track Titles and ID3 Tags) displayed on dot-matrix LCD
- Hyper-Bass Sound
- Anti-Shock Protection EX — For interruption-free reproduction even while jogging
- 40-Sec. (CD), 100-Sec. (MP3) Anti-Shock Memory for skip-free performance
- Program (64 Tracks)/Random/Repeat Play
- 20-Hour Continuous Playback (CD/MP3/WMA)
- Group Skip during MP3/WMA Playback (Forward/Reverse)
- Slim Design
- Grip Band

- Playable Formats: CD, CD-R/RW, MP3/WMA (CD-R/RW)
- Heat-Resistant Body
- 1-bit D/A Converter
- Auto Power Off
- Hold Switch
- DC Input Jack
- Backband-type Headphones

XL-PM6

Portable CD Player

ANTI-SHOCK PROTECTION
EX

Portable CD/MP3 Player with 40-Sec. (CD), 100-Sec. (MP3) Anti-Shock Memory and ID3 Tags Display

CD-R/RW
PLAYBACK

MP3
PLAYBACK

HBS

Grip  Band

- MP3 Text (Track Titles and ID3 Tags) displayed on dot-matrix LCD
- Hyper-Bass Sound
- Anti-Shock Protection EX — For interruption-free reproduction even while jogging
- 40-Sec. (CD), 100-Sec. (MP3) Anti-Shock Memory for skip-free performance
- Program (64 Tracks)/Random/Repeat Play
- 20-Hour Continuous Playback (CD/MP3)
- Group Skip during MP3 Playback (Forward/Reverse)
- Slim Design
- Grip Band
- Playable Formats: CD, CD-R/RW, MP3 (CD-R/RW)
- Heat-Resistant Body
- 1-bit D/A Converter
- Auto Power Off
- Hold Switch
- DC Input Jack
- Backband-type Headphones



XL-PM5

Portable CD Player

ANTI-SHOCK PROTECTION
EX

Portable CD/MP3 Player with 40-Sec. (CD), 100-Sec. (MP3)

CD-R/RW
PLAYBACK

Anti-Shock Memory

MP3
PLAYBACK

HBS

Grip  Band

- Hyper-Bass Sound
- Anti-Shock Protection EX — For interruption-free reproduction even while jogging
- 40-Sec. (CD), 100-Sec. (MP3) Anti-Shock Memory for skip-free performance
- Program (64 Tracks)/Random/Repeat Play
- 20-Hour Continuous Playback (CD/MP3)
- Slim Design
- Grip Band
- Playable Formats: CD, CD-R/RW, MP3 (CD-R/RW)
- Heat-Resistant Body
- 1-bit D/A Converter
- Auto Power Off
- Hold Switch
- DC Input Jack
- Backband-type Headphones



XL-PG3

Portable CD Player

ANTI-SHOCK PROTECTION
EX

Portable CD Player with 45-Sec. Anti-Shock Memory

CD-R/RW
PLAYBACK

- Hyper-Bass Sound
- Anti-Shock Protection EX — For interruption-free reproduction even while jogging
- 45-Sec. (CD)

HBS

Grip  Band

- Anti-Shock Memory for skip-free performance
- Program (32 Tracks)/Random/Repeat Play
- 20-Hour Continuous Playback
- Slim Design
- Grip Band
- Playable Formats: CD, CD-R/RW
- Heat-Resistant Body
- 1-bit D/A Converter
- Auto Power Off
- Hold Switch
- DC Input Jack
- Backband-type Headphones



Specifications

Portable CD Players

		XL-PR70	XL-PM6	XL-PM5	XL-PG3
CD PLAYER					
Playable Formats	CD	●	●	●	●
	CD-R/RW	●	●	●	●
	MP3 (CD-R/RW)	●	●	●	
	WMA (CD-R/RW)	●			
Display					
MP3 Text Display	Track Title	● (Dot-Matrix)	● (Dot-Matrix)	●	●
	ID3 Tag	●	●		
ANTI-SHOCK PROTECTION EX					
Anti-Shock Memory	CD	40 Sec.	40 Sec.	40 Sec.	45 Sec.
	MP3	100 Sec.	100 Sec.	100 Sec.	
Hyper-Bass Sound					
Heat-Resistant Body					
1-bit D/A Converter					
Program Play		● (64 Tracks)	● (64 Tracks)	● (64 Tracks)	● (32 Tracks)
Random Play		●	●	●	●
Repeat Play		●	●	●	●
Group Skip	MP3	● (Forward/Reverse)	● (Forward/Reverse)	● (Forward Only)	
	WMA	● (Forward/Reverse)			
Auto Power Off					
Hold Switch					
Play Time (Alkaline)	CD	20 Hours	20 Hours	20 Hours	20 Hours
Batteries, ASP OFF)	MP3	20 Hours	20 Hours	20 Hours	
	WMA	20 Hours			
PHONES					
DC IN Jack					
TUNER					
Band					
FM					
Digital Tuner					
●					
Preset Stations					
20 FM					
PROVIDED ACCESSORIES					
Headphones	Backband-type	●	●	●	●
	Grip Band	●	●	●	●
GENERAL					
Power Output (at 10% THD, 16 ohms)	Headphones	9mW x 2	9mW x 2	9mW x 2	9mW x 2
Power Source	AC	120V, 60Hz	120V, 60Hz	120V, 60Hz	120V, 60Hz
	DC	2 x 15A, AA Size	2 x 15A, AA Size	2 x 15A, AA Size	2 x 15A, AA Size
Dimensions (W x H x D)	in.	5 ⁷ / ₁₆ x 1 ¹ / ₁₆ x 5 ⁵ / ₁₆	5 ⁷ / ₁₆ x 1 ¹ / ₁₆ x 5 ⁵ / ₁₆	5 ⁷ / ₁₆ x 1 ¹ / ₁₆ x 5 ⁵ / ₁₆	5 ⁷ / ₁₆ x 1 ¹ / ₁₆ x 5 ⁵ / ₁₆
	mm	138 x 26 x 138	138 x 26 x 138	138 x 26 x 138	138 x 26 x 138
Weight (Without batteries)	oz.	9.1	8.8	8.5	8.1
	g	260	250	240	230

Compact Component Systems

		HX-D7	HX-C6	MX-GC5	MX-KC4
AMPLIFIER/TUNER					
Power Output	Subwoofer	180 watts per channel, min. RMS, driven into 6 ohms, at 63Hz, with no more than 10% total harmonic distortion	170 watts per channel, min. RMS, driven into 6 ohms, at 63Hz, with no more than 10% total harmonic distortion	160 watts per channel, min. RMS, driven into 6 ohms, at 63Hz, with no more than 10% total harmonic distortion	
	Main Speaker	80 watts per channel, min. RMS, driven into 4 ohms, at 1kHz, with no more than 10% total harmonic distortion	80 watts per channel, min. RMS, driven into 4 ohms, at 1kHz, with no more than 10% total harmonic distortion	70 watts per channel, min. RMS, driven into 6 ohms, at 1kHz, with no more than 10% total harmonic distortion	180 watts per channel, min. RMS, driven into 6 ohms, at 1kHz, with no more than 10% total harmonic distortion
Total Harmonic Distortion at Half-Rated Power		0.07% (63Hz, at Subwoofer)	0.07% (63Hz, at Subwoofer)	0.08% (1kHz, at Main Speaker)	0.08% (1kHz)
RHYTHMAX		●	●	●	●
Live Surround (DANCE CLUB/HALL/STADIUM)		●	●	●	
Sound Mode (ROCK/POP/CLASSIC)		●	●	●	●
Multi-Amp Configuration		●	●	●	
Subwoofer Level Control (3-Step)		●	●	●	
Extended Super Bass		●	●	●	
Eco Mode		●	●	●	
AUX Input (Stereo Mini Jack on Front Panel)		●	●	●	●
USB Input			●		
Preset Stations		15 AM, 30 FM	15 AM, 30 FM	15 AM, 30 FM	15 AM, 30 FM
DVD/CD PLAYER					
Playable Formats	DVD-Audio	●			
	DVD-Video	●			
	DVD-RW (Video Format)	●			
	DVD-R	●			
	CD	●	●	●	●
	CD-R/RW	●	●	●	●
	SVCD	●			
	VCD	●			
	MP3 (CD-R/RW)	●	●	●	●
	JPEG Digital Still (CD-R/RW)	●			
Mechanism Type		5-DVD Tray	5-CD Tray	3-CD Carousel	3-CD Carousel
Play & Exchange System		●	●	●	●
Horizontal Resolution		500 Lines			
Output Signal Level	Component - Y	1Vp-p/75 ohms			
	Component - Pb/Pr	0.7Vp-p/75 ohms			
	S-Video - Y	1Vp-p/75 ohms			
	S-Video - C	0.286Vp-p/75 ohms			
	Composite	1Vp-p/75 ohms			
Dynamic Range		90dB	90dB	85dB	85dB
Signal-to-Noise Ratio		90dB	90dB	85dB	85dB
Total Harmonic Distortion		0.01%	0.01%	0.08%	0.08%
Digital Direct Progressive Scan Output		●			
Express Play Start		●			
Rolling Pickup		●			
1-bit Dual D/A Converter			●	●	●
10-bit/54MHz Video D/A Converter		●			
Video Output Component		●			
Zoom/Multi Angle/Slow Motion		●			
VFP (Video Fine Processor)		Normal/Cinema/User 1/User 2			
Audio Decoder		● (2ch Downmix) DOLBY DIGITAL dts ● (2ch Downmix)			
3D-PHONIC (Action/Drama/Theater)		●			
192kHz/24-bit Audio D/A Converter		●			
Number of Programs		99	32	32	32
Repeat Play (1 Track/1 CD/ALL CDs)		●	●	●	●
Continuous Play		●	●	●	●
Smart Random Play		●	●	●	●
Optical Digital Output		●			
Tray-Lock Function		●	●	●	●
CASSETTE DECK					
Frequency Response					63 - 12,500Hz (Normal)
Signal-to-Noise Ratio (Measured at peak level, weighted.)					45dB (Normal)
Wow and Flutter					0.15% (WRMS)
Type					Double Deck
Full-Logic Control					●
Disc Synchro-Start Recording					●
Disc Rec Start/Stop Button					●
Dubbing					●
GENERAL					
Programmable Timer (Daily/Rec/Sleep)		● (except Rec)	● (except Rec)	● (except Rec)	●
COMPU PLAY					
Level Meter		●	●	●	●
Rotary Encoder Volume Control		●	●	●	●
Headphone Output		●	●	●	●
Demo Mode		●	●	●	●
BEEP Sound		●	●	●	●
Dimensions (W x H x D)	in.	6 ¹⁵ / ₁₆ x 14 ¹¹ / ₁₆ x 15 ³ / ₈	6 ¹⁵ / ₁₆ x 14 ¹¹ / ₁₆ x 15 ³ / ₈	10 ¹¹ / ₁₆ x 12 ¹ / ₁₆ x 19 ⁹ / ₁₆	10 ¹¹ / ₁₆ x 12 ¹ / ₁₆ x 18
	mm	175 x 373 x 389	175 x 373 x 389	270 x 305 x 490	270 x 306 x 456
Weight	lbs.	22.3	21.6	18.3	19
	kg	10.1	9.8	8.3	8.6
SPEAKERS					
GIGA-TUBE Low Pass Advanced Labyrinth Aero TUBE Subwoofer		●	●	●	
Magnetically Shielded		●			
Punched Metal Grilles		●	●	●	●
Type		4-Way, Bass-Reflex	4-Way, Bass-Reflex	3-Way, Bass-Reflex	3-Way, Bass-Reflex
	Subwoofer	6 ⁷ / ₁₆ " (16cm), Cone	6 ⁷ / ₁₆ " (16cm), Cone	6 ⁷ / ₁₆ " (16cm), Cone	
	Woofer	6 ⁷ / ₁₆ " (16cm), Cone	6 ⁷ / ₁₆ " (16cm), Cone	4 ⁹ / ₁₆ " (12cm), Cone	6 ⁷ / ₁₆ " (16cm), Cone
	Midrange	2 ⁷ / ₁₆ " (7cm), Cone	2 ⁷ / ₁₆ " (7cm), Cone		2" (5cm), Cone
	Tweeter	1 ³ / ₁₆ " (2cm), Dome	1 ³ / ₁₆ " (2cm), Dome	2" (5cm), Cone	1 ³ / ₁₆ " (2cm), Dome
Power Handling Capacity	Subwoofer	180 watts per channel, 6 ohms, 63Hz	170 watts per channel, 6 ohms, 63Hz	160 watts per channel, 6 ohms, 63Hz	
	Main Speaker	80 watts per channel, 4 ohms, 1kHz	80 watts per channel, 4 ohms, 1kHz	70 watts per channel, 6 ohms, 1kHz	180 watts per channel, 6 ohms, 1kHz
Impedance	Subwoofer	6 ohms	6 ohms	6 ohms	
	Main Speaker	4 ohms	4 ohms	6 ohms	6 ohms
Dimensions (W x H x D)	in.	11 ³ / ₈ x 17 ¹³ / ₁₆ x 15 ³ / ₈	11 ³ / ₈ x 17 ¹³ / ₁₆ x 15 ¹ / ₄	9 ⁹ / ₁₆ x 17 ¹ / ₈ x 12 ¹ / ₁₆	10 ¹ / ₂ x 13 ¹ / ₈ x 9 ¹ / ₂
	mm	295 x 452 x 390	295 x 452 x 387	242 x 454 x 315	266 x 333 x 241
Weight	lbs.	19.7	19	13.7	8.6
	kg	8.9	8.6	6.2	3.9

CD Portable Systems

		RV-NB1	PC-X290
CD PLAYER			
Playable Formats	CD	●	●
	CD-R/RW	●	●
	MP3 (CD-R/RW)	●	●
1-bit D/A Converter			
Number of Programs		50	20
Random Play		●	●
Repeat Play		●	●
Intro Scan		●	●
Twist Auto Lock CD Door		●	●
AMPLIFIER			
Power Output	FTC (with no more than 10% THD)	Full-Range: 6 watts per channel, min. RMS, driven into 4 ohms, from 150Hz to 15kHz; Super Woofer: 20 watts per channel, min. RMS, driven into 4 ohms, at 60Hz	5 watts per channel, min. RMS, driven into 3.2 ohms, at 1kHz
MP3 Text Display	Track Title ID3 Tag	●	●
EQ Patterns		4 Presets (FLAT/BEAT/POP/CLEAR)	5 Presets (FLAT/CLASSIC/ROCK/JAZZ/POP)
4-Amp Configuration			
Hyper-Bass Sound System		●	●
Bass Sound System		Super Woofer (with Volume Control)	
ACS (Active Clear Sound)		●	●
COMPU PLAY		●	●
Independent Guitar and Mic Inputs with Level Controls		Guitar/Mic Input x 1	
Built-in Guitar Amp		●	●
TUNER			
Band		AM/FM	AM/FM
Preset Stations		15 AM, 30 FM	10 AM, 10 FM
Digital Tuner		●	●
Auto Preset		●	●
CASSETTE DECK			
Full-Logic Control		●	●
Auto-Reverse		●	●
Dual Cassette		●	●
Full Auto Stop		●	●
CD Synchro-Start Recording		●	●
Twist Auto Lock Cassette Door		●	●
SPEAKERS			
Type	Full-Range	3 ⁹ / ₁₆ " (8cm) x 2	
	Super Woofer	6 ⁷ / ₁₆ " (16cm) x 2	
	Woofer		4" (10cm)
	Tweeter		2" (5cm)
Bass-Reflex Design		●	●
Detachable		●	●
Duct		Super Twin Long Ducts	
Super Woofer with 6-Layer Voice Coil		●	●
GENERAL			
Back Illuminated LCD		● (Blue)	● (Amber)
Clock/Daily Timer		●	●
Sleep Timer		●	●
Remote Control		● (Full Function)	●
Shoulder Strap with Remote Control Case Provided		●	●
Volume Jog Control		●	●
AUX IN			
PHONES/AC IN Jacks		●●	●●
Power Source	AC	120V, 60Hz	120V, 60Hz
	DC/Battery	R20 x 10	D (13F) x 8
	DC/External Battery	DC 12V	DC 12V
Dimensions (W x H x D)	in.	27 ⁷ / ₁₆ x 9 ⁷ / ₁₆ x 11 ¹¹ / ₁₆	25 ¹ / ₄ x 10 ⁹ / ₁₆ x 11 ³ / ₄
	mm	690 x 239 x 296	640 x 274 x 298
Weight (Without batteries)	lbs.	20.9	16.6
	kg	9.5	7.5

		RC-EX36	RC-EX26	RC-EX16
CD PLAYER				
Playable Formats	CD	●	●	●
	CD-R/RW	●	●	●
	MP3 (CD-R/RW)	●	●	●
1-bit D/A Converter				
Number of Programs		40	20	20
Random Play		●	●	●
Repeat Play		●	●	●
Intro Scan		● (CD Only)	● (CD Only)	
AMPLIFIER				
Power Output	FTC (with no more than 10% THD)	2 watts per channel, min. RMS, driven into 4 ohms, at 1kHz	2 watts per channel, min. RMS, driven into 4 ohms, at 1kHz	2 watts per channel, min. RMS, driven into 4 ohms, at 1kHz
MP3 Text Display	Track Title ID3 Tag	●		
EQ Patterns		5 Presets (FLAT/CLASSIC/ROCK/JAZZ/POP)	5 Presets (FLAT/CLASSIC/ROCK/JAZZ/POP)	
Hyper-Bass Sound System				
TUNER				
Band		AM/FM	AM/FM	AM/FM
Preset Stations		10 AM, 20 FM	10 AM, 10 FM	
Digital Tuner		●	●	●
CASSETTE DECK				
CD Synchro-Start Recording		●	●	●
SPEAKERS				
Type	Full-Range	3 ⁹ / ₁₆ " (9cm) x 2	3 ⁹ / ₁₆ " (9cm) x 2	3 ⁹ / ₁₆ " (9cm) x 2
	Super Woofer			
GENERAL				
Back Illuminated LCD		● (Blue)	● (Amber)	
Remote Control		●	●	●
PHONES/AC IN Jacks		●●	●●	●●
Power Source	AC	120V, 60Hz	120V, 60Hz	120V, 60Hz
	DC	R20 x 6	R20 x 6	R20 x 6
Dimensions (W x H x D)	in.	16 ⁹ / ₁₆ x 7 ¹ / ₁₆ x 9 ¹³ / ₁₆	16 ⁶ / ₁₆ x 7 ¹ / ₁₆ x 9 ¹³ / ₁₆	16 ⁹ / ₁₆ x 7 ¹ / ₁₆ x 9 ¹³ / ₁₆
	mm	420 x 178 x 249	420 x 178 x 249	420 x 178 x 249
Weight (Without batteries)	lbs.	7.1	7.1	7.1
	kg	3.2	3.2	3.2

Digital Audio Player

		XA-A50CL
GENERAL		
Type		Flash Memory
Storage Capacity		128MB
Supported OS		Windows® XP/Windows® Me, Windows® 2000, Windows® 98SE
Audio Support		MP3, WMA*
Connectivity		USB 1.1 Connection (USB 2.0 Compatible)
Windows Media DRM** Support		● (DRM9)
Music Play by Sort (Artist/Album/Genre/Track/Playlist)		● (Playlist)
Program Play		● (Playlist)
Digital Surround		● (SRS TruBass/WOW)
Preset EQ		● (5-Mode)
Bass Boost		● (SRS TruBass)
Repeat Mode		●
Play Mode		Repeat/All Repeat/Random/Random Repeat
Playback Time (MP3 128Kbps Playback)		20 Hours
Menu Languages		Eng./Fre./Ger./Ita./Spa./Dut./Swe./Por./Chi.
Playback Time		20 Hours
Voice Control Guide		●
Dimensions (W x H x D)	in.	1 ¹⁵ / ₁₆ x 2 ⁷ / ₈ x 1
	mm	45 x 53 x 25 (Right side w/o ear hook)
Weight	lbs.	1.26
	g	57 (Including battery)
PROVIDED ACCESSORIES		
USB Cable		USB 1.1 Cable
Battery Type		1 x AAA Alkaline
CD-ROM		● (USB Driver for Windows® 98SE, Instructions, 9 Voice Guide Languages)

* MP3/WMA files stored in the PLAYER cannot be transferred to external devices. Stored files without DRM protection are automatically deleted when the unit is connected to a PC via USB.

** Windows Media™ DRM - Microsoft® Windows Media™ Digital Rights Management



Newport Jazz Festival is a registered service mark of George Wein and Festival Productions, Inc. Jamie Cullum photographed at the 2004 JVC International Jazz Festival.

Design and specifications subject to change without notice. The photos of the products featured in this brochure may not be of actual products that are available in your country.

All brand or product names may be trademarks and/or registered trademarks of their respective owners. Any rights not expressly granted herein are reserved.

Copyright © 2005, Victor Company of Japan, Limited (JVC). All Rights Reserved.



DISTRIBUTED BY

JVC COMPANY OF AMERICA
DIVISION OF JVC AMERICAS CORP.
1700 Valley Road, Wayne, N.J. 07470
CONSUMER INFORMATION CENTER
1-800-252-5722

<http://www.jvc.com>

"JVC" is the trademark or registered trademark of Victor Company of Japan, Limited.