

# JVC

SYSTEMS &  
PORTABLE  
AUDIO

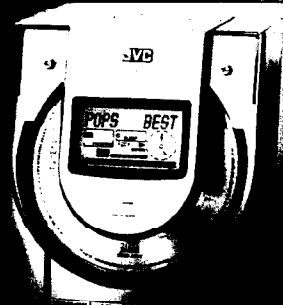
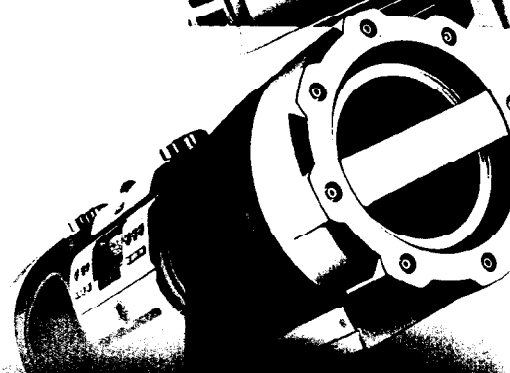
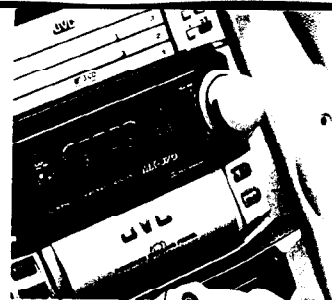

FS Series  
MrX Series

Portable Freedom!

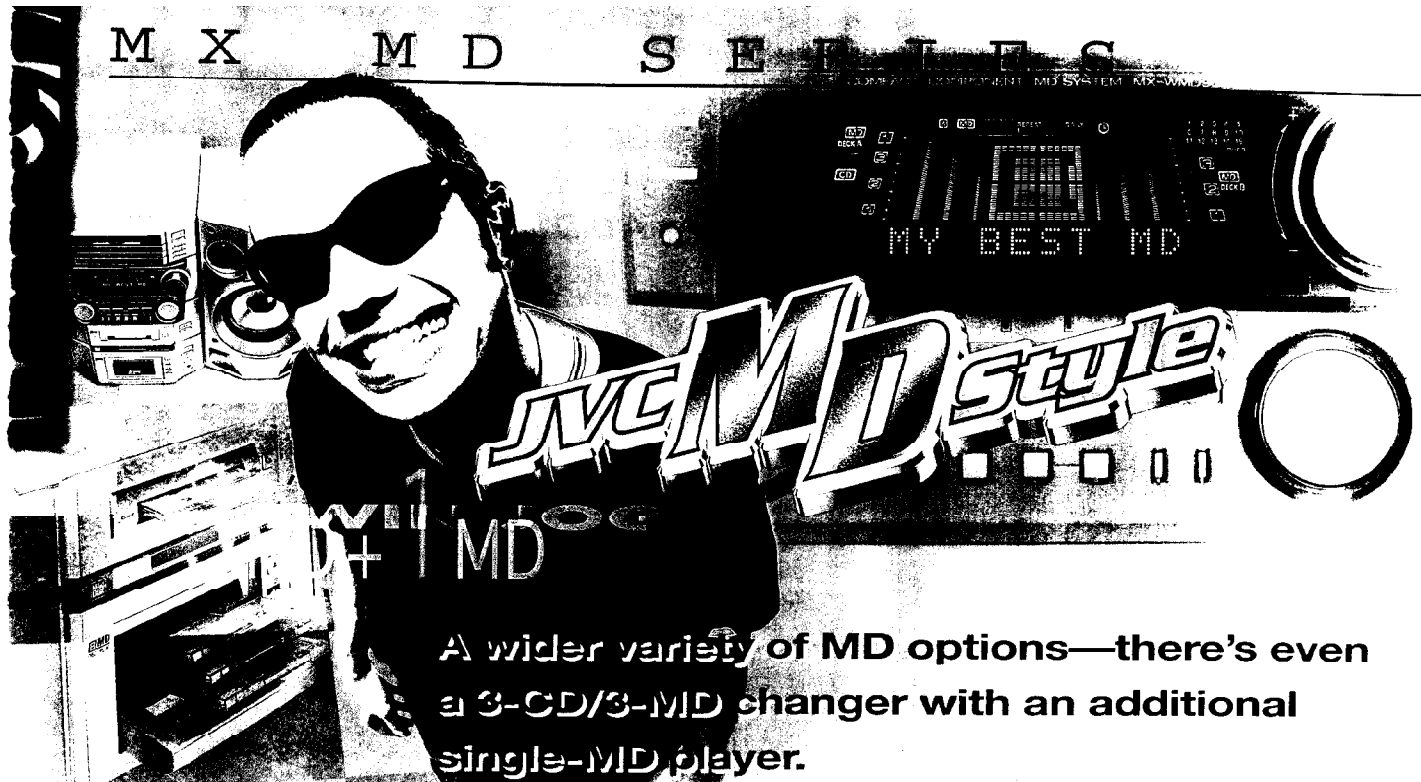

A wider variety of MD options—there's even a 3-CD/3-MD changer with an additional single-MD player.

**3-MD recorder/3-CD changer**

The MX-WMD90 features both high-quality digital sound and exceptional editing versatility, thanks to the combination 3-MD

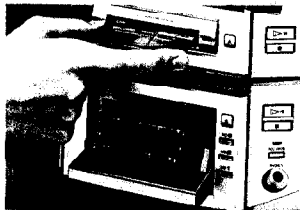

recorder, 3-CD changer and single-MD player. Here are the unique assemble edit functions this versatile system offers:

- **TRIPLE REC:** Sequentially dubs three CDs on three MDs. With the MX-WMD90, you can dub while enjoying an MD in the single MD player or AUX program at the same time.
- **1ST TRACK REC:** Sequentially records the first track of each CD onto an MD.
- **LONG REC:** Records any source (CD, FM program, tape, etc.) on up to three MDs in sequence.
- **MD-to-MD DUBBING (MX-WMD90):** Titles and other data on the master MD are

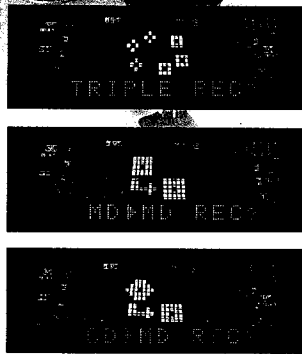

● **MD TITLE RESERVE (MX-WMD90):** You can input the titles of 16 tracks ahead of time, even while recording is under way.

Moreover, the 3-MD recorder's **power-loading system** allows easy one-touch loading and unloading of up to three discs. MD trays are conveniently angled to facilitate loading and unloading.

The MX-MD70 is another dual-disc format combining a 3-disc CD changer and a single-MD recorder with **1ST TRACK REC** capability and easy MD title input. Also like the MX-WMD90, this MD/CD

combination features the Play & Exchange System, letting you change two discs while the third is being played, all without stopping music.

**Multi Jog Control**

The Multi Jog Control is one device that does it all. It makes system use amazingly simple—fingertip control at its best. Using a single control, you can choose a track from a CD or an MD, give names to MD tracks, and set the built-in clock/timer.

● **Twin Jog Controls (MX-WMD90):** The Recording Jog is used to select the record mode and program sources, while the Multi Jog is convenient for title display, title entry, track search, timer setting and MD editing. Edge lights in the jog dials guide you through operations.

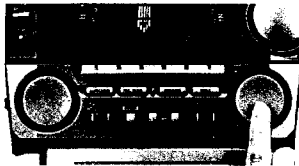

● **Cylindrical Multi Jog (MX-MD70):** This is a backlit cylinder that you turn to scroll through tracks, track names, character set, etc., displayed on

the 4-line LCD. To input a title, you scroll through a row/column matrix of letters and numbers, quickly accessing desired alphanumerics on the large LCD.

**Live Surround**

The Live Surround Circuit features three settings for processing the input signals for a sound that spreads beyond the stereo speakers.

**Dual Cannon Duct System**

The Dual Cannon Duct System is a JVC innovation that extracts clean bass from a compact enclosure. It has an internal construction just like a car's muffler, with a succession of narrow, wide, and finally, narrow passages. The design intensifies low-frequency sound pressure for dynamic bass. The bass remains clean and sharp because as it passes through the duct, unwanted high-frequency sound is filtered out.

**Angled surround speaker (MX-WMD90)**

The 3 way, 4 speaker system features an extra speaker angled outward that helps expand the width of the virtual soundstage.

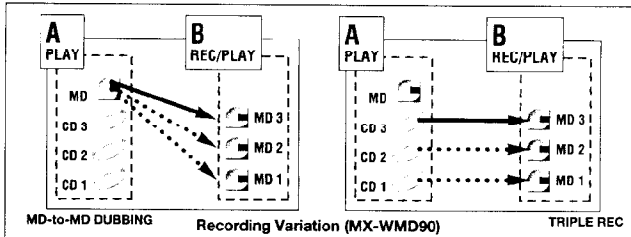
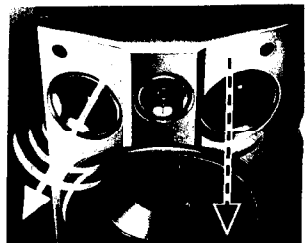

## MX-WMD90

Compact Component MD System



- ◆ 3-CD/3-MD/Single-MD system
- ◆ CD-to-MD dubbing while listening to Single MD, TAPE or AUX
- ◆ MD-to-MD dubbing with auto title copy
- ◆ "MD title reserve" function
- ◆ Continuous 4-MD playback
- ◆ Twin jog controls: Multi Jog and Record Jog

### Amplifier/General

- ◆ Power output: 50 watts per channel (3% THD)
- ◆ Graphical fluorescent display
- ◆ Active Bass Extension (on/off)
- ◆ SPI (Spectro Peak Indicator)
- ◆ Live Surround
- ◆ 6 preset electronic equalizations plus 1 manual setting
- ◆ AUX/TAPE inputs
- ◆ COMPU PLAY
- ◆ Remote control with MD title input



JVC MD Style

DOUBLE-MD DECK

### Tuner

- ◆ 15 AM and 30 FM station memory
- ◆ Programmable timer (Daily, Record, Sleep)

### 3-CD Triple-Tray Changer

- ◆ 3 trays with Play & Exchange System
- ◆ Dual 1-bit D/A converters
- ◆ 15-track program chart
- ◆ 3-disc program (32 tracks)/smart random/repeat play

### 3-MD Changer and Single-MD Player

- ◆ Play & Exchange System
- ◆ 1-bit D/A and A/D converters
- ◆ 5-mode MD edit functions (DIMDE/JOIN/MOVE/ERASE/ALL ERASE)
- ◆ Program (32 tracks)/smart random/repeat play
- ◆ TRIPLE REC: To record 3 CDs on 3 MDs
- ◆ 1st TRACK REC: To record the first track of each CD
- ◆ LONG REC: To make recording on 3 MDs consecutively for up to 222 minutes

- ◆ Listening edit
- ◆ CD synchro start recording
- ◆ Auto/manual track marking
- ◆ Sampling rate converter
- ◆ Optical digital input

### Speaker System

- ◆ 3-way, 4-speaker bass-reflex design: 5<sup>15</sup>/<sub>16</sub>-inch (15cm) cone woofer, 2<sup>1</sup>/<sub>2</sub>-inch (6cm) and 2<sup>1</sup>/<sub>2</sub>-inch (5cm) cone midrange, 1<sup>3</sup>/<sub>8</sub>-inch (1.5cm) dome tweeter
- ◆ Dual Cannon Duct System
- ◆ Magnetically shielded

## MX-MD70

Compact Component MD System



- ◆ Large aquamarine-blue LCD panel
- ◆ Cylindrical Multi Jog Control with back light

### Amplifier/General

- ◆ Power output: 50 watts per channel (3% THD)
- ◆ Large aquamarine-blue LCD panel: Remote enlargement function and 4-MD title display
- ◆ Active Bass Extension (on/off)
- ◆ 2-mode level meters
- ◆ Live Surround
- ◆ 3 preset electronic equalizations plus 1 manual setting
- ◆ AUX/TAPE inputs
- ◆ COMPU PLAY
- ◆ Remote control with MD title input

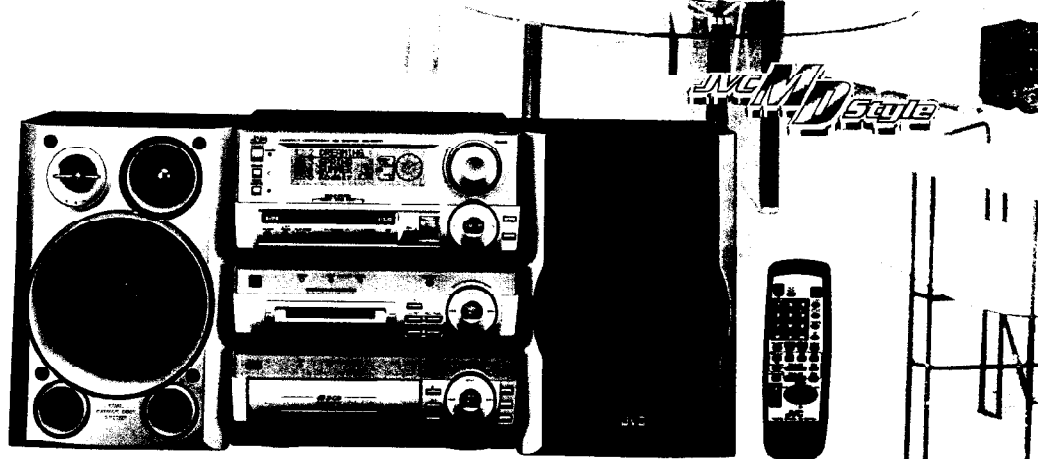

JVC MD Style

### Tuner

- ◆ 15 AM and 30 FM station memory
- ◆ Programmable timer (Daily, Record, Sleep)

### 3-CD Triple-Tray Changer

- ◆ 3 trays with Play & Exchange System
- ◆ Dual 1-bit D/A converters
- ◆ 3-disc program (32 tracks)/smart random/repeat play

### MD Recorder

- ◆ Title input during recording or playback—even from remote
- ◆ 1-bit D/A and A/D converters
- ◆ 5-mode MD edit functions (DIMDE/JOIN/MOVE/ERASE/ALL ERASE)
- ◆ Program (32 tracks)/smart random/repeat play
- ◆ 1st TRACK REC: To record the first track of each CD at a touch
- ◆ Listening edit

- ◆ CD synchro start recording
- ◆ Auto/manual track marking
- ◆ Sampling rate converter
- ◆ Optical digital input

### Speaker System

- ◆ 3-way bass-reflex design: 5<sup>9</sup>/<sub>16</sub>-inch (13.5cm) cone woofer, 2<sup>1</sup>/<sub>2</sub>-inch (5cm) cone midrange, 5<sup>8</sup>/<sub>16</sub>-inch (1.5cm) dome tweeter
- ◆ Dual Cannon Duct System
- ◆ Magnetically shielded

Notice: It should be noted that it may be unlawful to re-record pre-recorded tapes, records, or CDs without the consent of the owner of copyright in the sound or video recording, broadcast or cable program and in any literary, musical, or artistic work embodied therein.

# M X S E R I E S

The functional and smart **Powered Rolling Panel** breaks new ground in ease of use. The line highlights a wider selection of speaker configurations. Choose the system that best suits your hi-fi needs.



## POWERED ROLLING PANEL

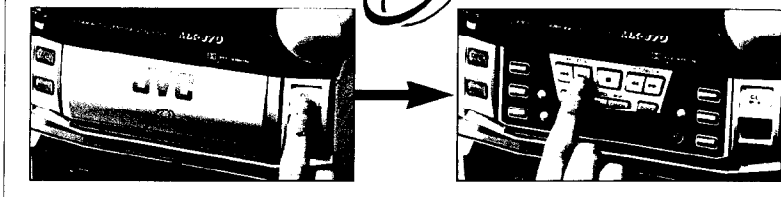

### Powered Rolling Panel

To start the music, touch any key on the front panel: the rolling control panel comes into view, revealing keys for sound adjustment and source control. With a touch of the PANEL OPEN/CLOSE key, the system presents a clean look, concealing the secondary controls. The Powered Rolling Panel gives the JVC Compact Component Systems a clean and sharp look, while improving ease of use.

### Labyrinth Aeroport Speaker Design (MX-J50)

JVC's exclusive labyrinth aeroport speaker design has been further improved. Back-generated bass sound is routed to the front through a newly configured labyrinth port, giving powerful, tight bass. The 6<sup>5</sup>/<sub>16</sub>-inch (16cm) woofer features double dampers to improve linearity and assure better high-power performance.

### Dual Cannon Duct System (MX-J70)

The Dual Cannon Duct System is a JVC innovation that extracts clean bass from a compact enclosure. It has an internal construction just like a car's muffler, with a succession of narrow, wide, and finally, narrow

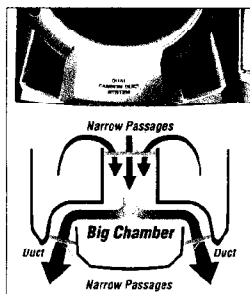

passages. The design intensifies low-frequency sound pressure for dynamic bass. The bass remains clean and sharp because as it passes through the duct, unwanted high-frequency sound is filtered out.

### S.A. BASS (Signal Adaptive Bass System) (MX-J70/J50)

Bass frequencies suffer from poor power linearity and are harder to hear than mid and treble frequencies—which is why many compact systems come with a bass boost circuit. Conventional bass boost circuits

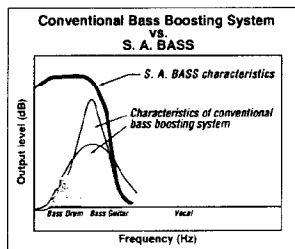

are designed to increase a specific frequency range, which sometimes alters the tonal character of the vocals and instruments.

Enter JVC's intelligent S.A. BASS (Signal Adaptive Bass System). First, the Bass Level Detection Circuit checks the level of low frequencies in the incoming signal and sets the optimum boosting levels. Then the Level Compensation Circuit applies the optimum amount of bass boost. You fully enjoy wide dynamic range as well as solid, rich bass from any music source—irrespective of volume level and program type.

### 3-CD Triple-Tray changer

The 3-disc changer comes with three separate disc trays on which to load discs. You can even pull out trays not currently in use and put in new discs for nonstop music. Separate 'OPEN/CLOSE' and DISC play keys for each tray make the changer easy to use.

### Velocity-sensitive rotary encoder volume control (all models)

The rotary encoder volume control provides a smooth controlled feel and features two operation modes. Turn the knob quickly to instantly increase or decrease the level, or turn it slowly to fine-adjust the level. Level is displayed on an attractive, easy-to-read fluorescent display.

### JVC Home-Theater Audio—Dolby Pro Logic with a package of five speakers (MX-J70)

Dolby Pro Logic is a must for the complete enjoyment of exciting theater sound at home: the MX J70 features a center speaker and a pair of surround speakers, as well as a Dolby Pro Logic decoder, a separate amp for each channel, and front speakers.

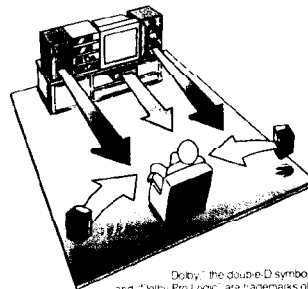

Dolby, the double-D symbol and "Dolby Pro Logic" are trademarks of Dolby Laboratories Licensing Corporation.

### COMPU PLAY (all models)

Just touch a single button to choose a source (CD, cassette or tuner), and the system will automatically turn on and initiate all steps to start the music.

# MX-J70

Compact Component System



**POWERED ROLLING PANEL**

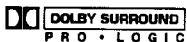

**S.A. BASS**

### Amplifier/General

- ◆ Power output: Front: 120 watts per channel; Center: 30 watts; Rear: 15 watts per channel
- ◆ Powered Rolling Panel
- ◆ Dolby Pro Logic Surround—complete with 5 speakers
- ◆ Dolby 3 Stereo
- ◆ SPI (Spectro Peak Indicator)
- ◆ 3 preset electronic equalizations plus 3 manual settings
- ◆ AUX input/output
- ◆ Subwoofer output
- ◆ Live Surround
- ◆ S.A. BASS (2-step)
- ◆ Full-function remote control
- ◆ COMPU PLAY

### Tuner

- ◆ 15 AM and 30 FM station memory
- ◆ Programmable timer (Daily, Record, Sleep)

### 3-CD Triple-Tray Changer

- ◆ 3 trays with Play & Exchange System
- ◆ Dual 1-bit D/A converters
- ◆ 16-track program chart
- ◆ 3-disc program (32 tracks)/smart random/repeat play
- ◆ Auto edit functions
- ◆ Optical digital output

### Cassette Deck

- ◆ Double auto-reverse transports
- ◆ Full-logic control
- ◆ CD rec start button
- ◆ Auto tape selector (Normal/CrO<sub>2</sub>)
- ◆ Music Scan

### Speaker System

- ◆ Dual Cannon Duct System
- ◆ 3-way bass-reflex design:
  - ◆ 6<sup>3</sup>/<sub>16</sub>-inch (16cm) cone woofer
  - ◆ 2-inch (5cm) cone midrange
  - ◆ 1<sup>3</sup>/<sub>16</sub>-inch (2cm) dome tweeter
- ◆ Magnetically shielded
- ◆ Punched metal grilles (for midrange and tweeter)

### Center and Surround Speakers (included)

- ◆ 3<sup>3</sup>/<sub>16</sub>-inch (8cm) cone center speaker—magnetically shielded
- ◆ 3<sup>3</sup>/<sub>16</sub>-inch (8cm) cone surround speaker x 2

# MX-J50

Compact Component System

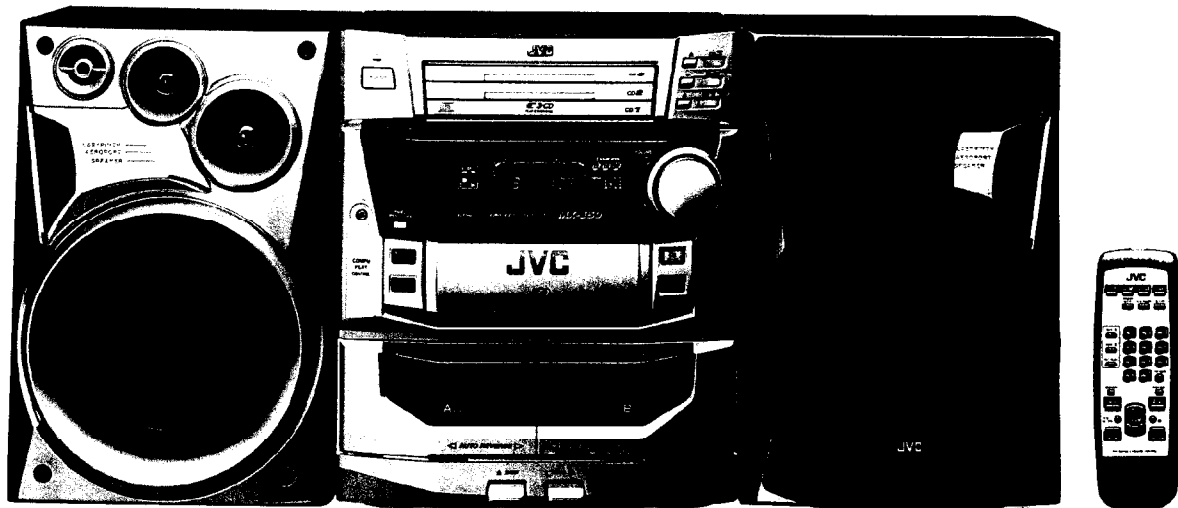

**POWERED ROLLING PANEL**

**S.A. BASS**

#### Amplifier/General

- ◆ Power output: 120 watts per channel
- ◆ Powered Rolling Panel
- ◆ SPI (Spectro Peak Indicator)
- ◆ 3 preset electronic equalizations plus 3 manual settings
- ◆ AUX input/output
- ◆ Subwoofer output
- ◆ Live Surround
- ◆ S.A. BASS (2-step)
- ◆ Full-function remote control
- ◆ COMPU PLAY

#### Tuner

- ◆ 15 AM and 30 FM station memory
- ◆ Programmable timer (Daily, Record, Sleep)

#### 3-CD Triple-Tray Changer

- ◆ 3 trays with Play & Exchange System
- ◆ Dual 1-bit D/A converters
- ◆ 16-track program chart
- ◆ 3-disc program (32 tracks)/smart random/repeat play
- ◆ Auto edit functions
- ◆ Optical digital output

#### Cassette Deck

- ◆ Double auto-reverse transports
- ◆ Full-logic control
- ◆ CD rec start button
- ◆ Auto tape selector (Normal/CrO<sub>2</sub>)
- ◆ Music Scan

#### Speaker System

- ◆ Labyrinth Aeroport Speaker System
- ◆ 4-way bass-reflex design:
  - 6<sup>5</sup>/<sub>16</sub>-inch (16cm) cone woofer
  - 2-inch (5cm) cone midrange
  - 1<sup>5</sup>/<sub>8</sub>-inch (4cm) cone tweeter
  - 1<sup>3</sup>/<sub>16</sub>-inch (2cm) dome supertweeter

# MX-J30

Compact Component System

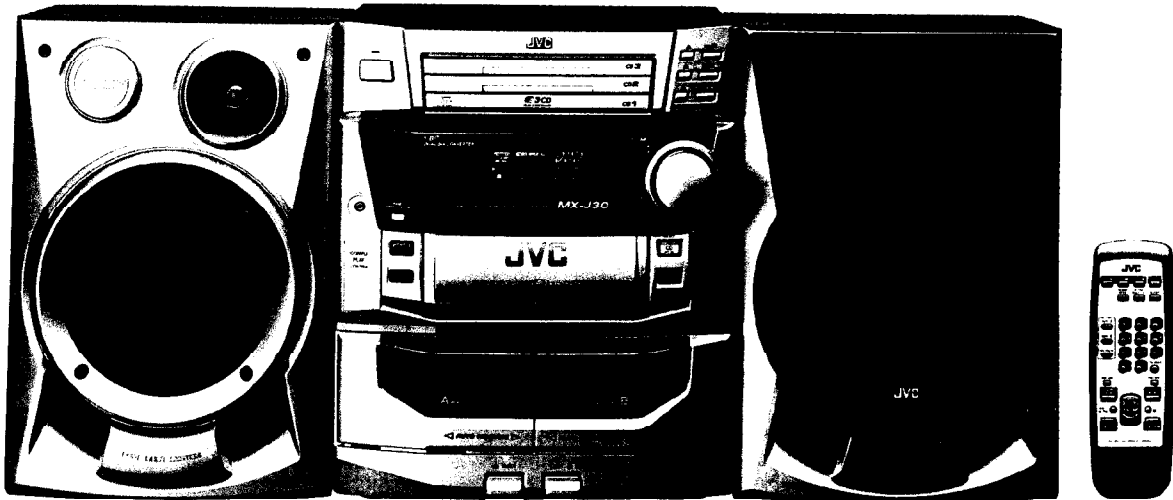

## POWERED ROLLING PANEL

### Amplifier/General

- ◆ Power output: 100 watts per channel
- ◆ Powered Rolling Panel
- ◆ 3 preset electronic equalizations
- ◆ Active Bass Extension (on/off)
- ◆ AUX input
- ◆ Live Surround
- ◆ Full-function remote control
- ◆ COMPU PLAY

### Tuner

- ◆ 15 AM and 30 FM station memory
- ◆ Programmable timer (Daily, Record, Sleep)

### 3-CD Triple-Tray Changer

- ◆ 3 trays with Play & Exchange System
- ◆ Dual 1-bit D/A converters
- ◆ 3-disc program (32 tracks)/smart random/repeat play

### Cassette Deck

- ◆ Double auto-reverse transports
- ◆ Full-logic control
- ◆ CD rec start button
- ◆ Auto tape selector (Normal/CrO<sub>2</sub>)
- ◆ Music Scan

### Speaker System

- ◆ 2-way bass-reflex design: 5<sup>15</sup>/<sub>16</sub> inch (15cm) cone woofer, 2-inch (5cm) dome tweeter
- ◆ Dual Duct System



# MX-J10

Compact Component System

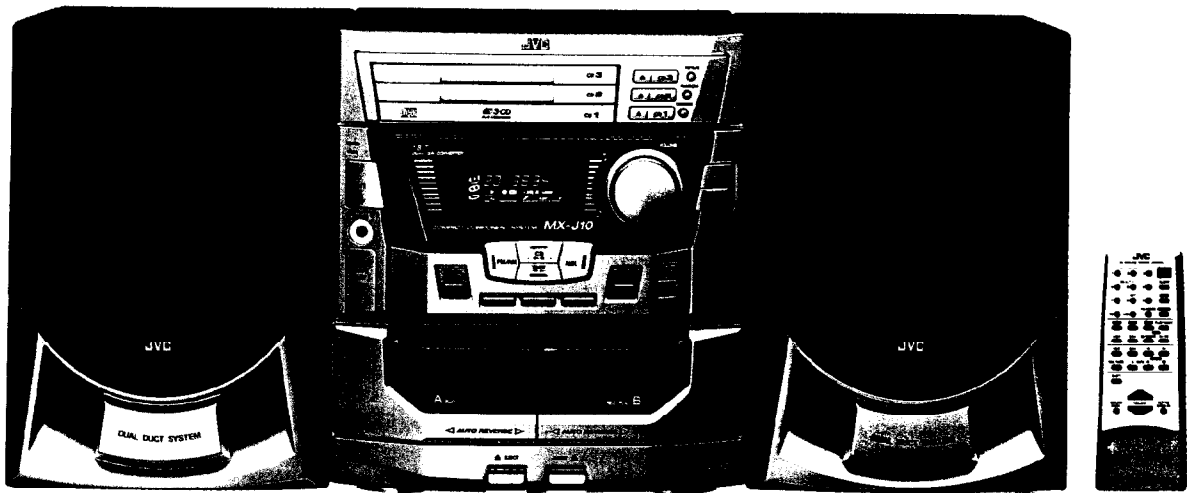

### Amplifier/General

- ◆ Power output: 60 watts per channel
- ◆ 3 preset electronic equalizations
- ◆ Active Bass Extension (on/off)
- ◆ AUX input
- ◆ Live Surround
- ◆ Full-function remote control
- ◆ COMPU PLAY

### Tuner

- ◆ 15 AM and 30 FM station memory
- ◆ Programmable timer (Daily, Record, Sleep)

### 3-CD Triple-Tray Changer

- ◆ 3 trays with Play & Exchange System
- ◆ Dual 1-bit D/A converters
- ◆ 3-disc program (20 tracks)/smart random/repeat play

### Cassette Deck

- ◆ Double auto-reverse transports
- ◆ Full-logic control
- ◆ CD rec start button
- ◆ Auto tape selector (Normal/CrO<sub>2</sub>)
- ◆ Music Scan

### Speaker System

- ◆ 2-way bass-reflex design:
  - 4<sup>3</sup>/<sub>4</sub>" each (12cm) cone woofer
  - 2-inch (5cm) cone tweeter
- ◆ Dual Duct System

# F S E R I E S

Your all-day musical companion—designed to match today's interiors and lifestyles. Stylish and easy to use as ever.

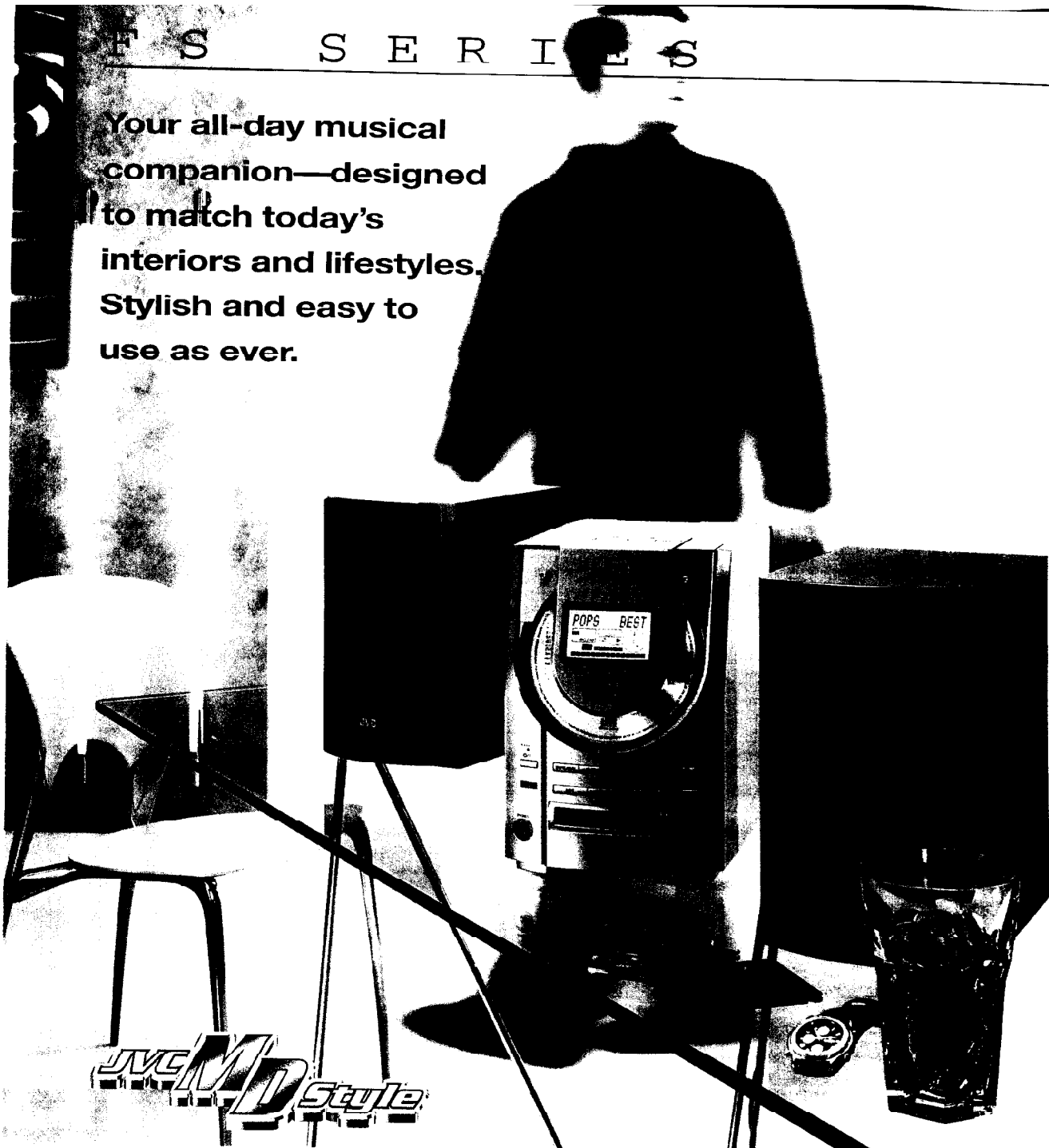

**JVC MD Style**

### Vertical CD loading system

This system is JVC's stylish approach to ease of use. Discs

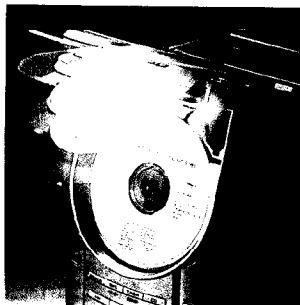

are mounted vertically at an angle. You can see the disc being played as it spins behind the glass.

### Motor-driven CD door with backlit LCD

Open or shut the CD door at the touch of a button, even from the

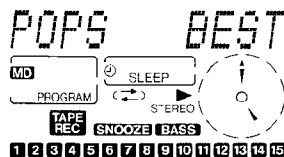

remote. This is another way to simplify audio operations.

### Active Hyper-Bass PRO

The Active Hyper-Bass PRO Sound System features a "Q" (bandwidth) control circuit instead of a cut-off frequency circuit. Dynamically controlling the range of the boost frequencies through feedback according to output level, it's capable of dynamic bass response and clear vocals, with no drop in the midrange response. The Active Hyper-Bass PRO Sound System actively controls the bass boost to let you

enjoy enriched bass response as well as clear vocals.

### COMPU PLAY

Just touch a single button to choose a source (CD, MD [cassette] or tuner), and the system will automatically turn on and initiate all steps to start the music.

### MDF (Medium-Density Fiberboard)

The MDF (Medium-Density Fiberboard) enclosure helps each system deliver crisp sound.

## FS-V9MD

FS Series MD  
Component System



### AHB PRO

#### Amplifier/General

- ◆ Power output: 17 watts per channel
- ◆ Active Hyper-Bass PRO
- ◆ Electronic bass/treble controls
- ◆ AUX input
- ◆ COMPU PLAY
- ◆ Clock/timer with snooze function

#### Tuner

- ◆ Digital tuner with auto preset
- ◆ 15 AM/30 FM station memory

#### CD Player

- ◆ Vertical loading system
- ◆ Motor-driven CD door with blue backlit LCD panel
- ◆ 1-bit D/A converter
- ◆ Program (20 tracks)/random/ repeat play
- ◆ 15-track program chart

#### MD Recorder

- ◆ 1-bit D/A and A/D converters
- ◆ 5-mode MD edit functions (Divide/Join/Move/Erase/ All Erase)
- ◆ Sampling rate converter (32kHz/44.1kHz/48kHz)

- ◆ Program (32 tracks)/random/ repeat play
- ◆ CD synchro start recording
- ◆ 15-track program chart
- ◆ Auto/manual track marking
- ◆ Optical digital input

#### Speaker System

- ◆ 2-way bass-reflex design: 3<sup>9</sup>/<sub>16</sub>-inch (96mm) cone woofer, 1<sup>1</sup>/<sub>2</sub>-inch (38mm) tweeter
- ◆ MDF (Medium-Density Fiberboard) enclosure
- ◆ Removable grilles
- ◆ Wood finish



JVC MD Style

VERTICAL  
LOADING  
CD SYSTEM

## FS-V5

FS Series Component  
System

### AHB PRO

#### Amplifier/General

- ◆ Power output: 16 watts per channel
- ◆ Champagne-gold front panel
- ◆ Active Hyper-Bass PRO
- ◆ Electronic bass/treble controls
- ◆ AUX input
- ◆ COMPU PLAY
- ◆ Clock/timer with snooze function

#### Tuner

- ◆ Digital tuner with auto preset
- ◆ 15 AM/30 FM station memory

#### CD Player

- ◆ Vertical loading system
- ◆ Motor-driven CD door with amber backlit LCD panel

- ◆ 1-bit D/A converter
- ◆ Program (20 tracks)/random/ repeat play
- ◆ 15-track program chart
- ◆ Optical digital output

#### Cassette Deck

- ◆ Full-logic control
- ◆ Auto-reverse record/play
- ◆ CD synchro/complete recording
- ◆ Auto tape selector (Normal/CrO<sub>2</sub>)

#### Speaker System

- ◆ Bass-reflex design: 3<sup>9</sup>/<sub>16</sub>-inch (8cm) full-range speakers
- ◆ MDF (Medium-Density Fiberboard) enclosure
- ◆ Wood finish



VERTICAL  
LOADING  
CD SYSTEM

# KABOOM BOX

The KABOOM BOX from JVC!  
It's an unshakable tubular  
CD portable that shakes you  
with deep bass sound.  
It's a guitar amp too for  
budding players.

# *Kaboom!*



**Super Twin Ducts (RV-B55)**  
 The KABOOM BOX has Super Twin Ducts for rock-bottom bass (RV-B55).

The Super Twin Ducts give your speakers a rich, deep sound. In your car, you'll hear a number of higher frequencies. A weight ring outside the woofer helps control the cone down to under 100 Hz. This woofer unit also has a foamed back to help to control

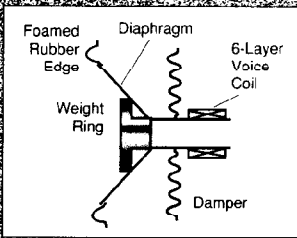

any vibrations caused by the Super Twin Ducts. They deliver crisp, extended bass sound with high radiation efficiency. A 6-layer voice coil cuts down the lowest resonance frequency and increases driving power. The woofer units also feature a foamed rubber surround to achieve both high clarity and low distortion.

**Built-in guitar amp (RV-B99)**

Brush up your guitar-playing skills or play quiet with your favorite musician on CD. The RV-B99 features a built-in guitar amp to let you rock with the greatest. The standard input jack connects to a guitar or mic. The level control switch adjusts volume, or changes sensitivity and frequency response according to the input. And the mixing facility lets you mix guitar or mic sound with CD sound.



**Super Twin Ducts**

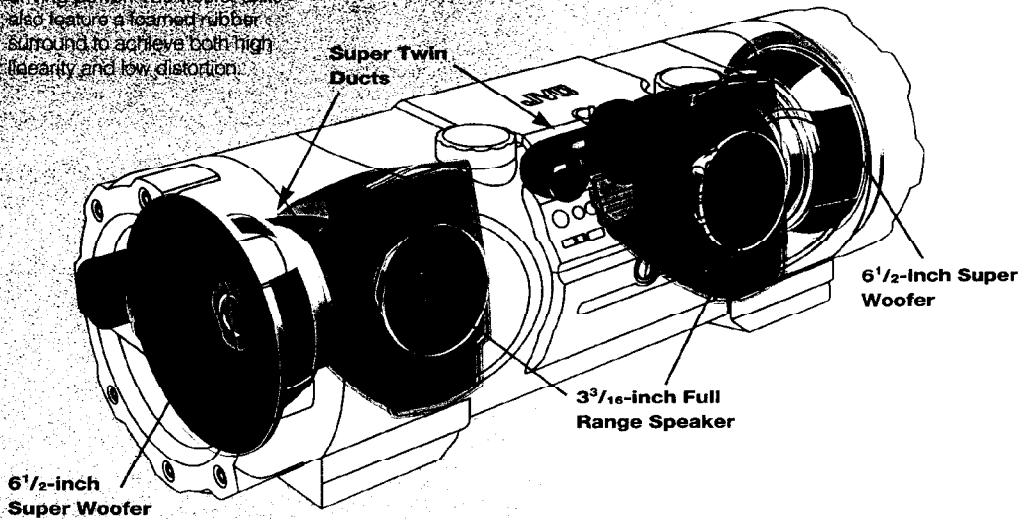

**Total 52W output—dynamic high power (RV-B99)**

The KABOOM BOX comes with two Super Woofers and two 3<sup>3</sup>/<sub>16</sub>-inch (8cm) full-range units—a total of four speakers. And there are two amps for the full-range units and another two exclusively for the dual woofers, delivering total power output of 52 watts. Using the Super Woofer volume control, you can add deep bass to the overall sound and adjust it to your liking.

**Long labyrinth ducts (RV-B55)**

The sound from the rear is routed through long, winding labyrinth ducts to extend the frequency response down to the lowest frequencies. This is another JVC approach to delivering a big sound from a small package.

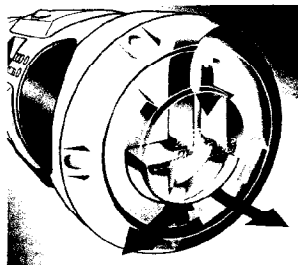

**Super Exciter Bass Circuit**

This is a compressor circuit that achieves deep, rich bass. It works by shifting inaudibly low frequencies into an audible, higher frequency range and adding them to the original sound, with the audible sounds boosted.

**ACS (Active Clear Sound)**

ACS actively controls high frequencies to prevent deterioration of the signal-to-noise ratio and improve clarity for better balance with deep lows. The circuit delivers balanced response over the entire audible range by activating only when a high-frequency signal occurs.



**RV-B99BK**



**RV-B99GV**

## RV-B99

### Powered Woofer CD System

- ◆ Standard jack for guitar/mic input with level control
- ◆ Built-in guitar amp
- ◆ Mixing CD with guitar sound
- ◆ Twin 6 1/2-inch (16cm) Super Woofers with 6-layer voice coil and weight ring
- ◆ Super Woofer volume control
- ◆ Full-function remote control
- ◆ Super twin ducts
- ◆ Rugged tubular construction
- ◆ Super Exciter Bass circuit
- ◆ High power: Total 52 watts
- ◆ Twist lock CD and cassette doors
- ◆ Full-logic auto-reverse cassette deck
- ◆ AUX input
- ◆ Backlit LCD
- ◆ 3 preset equalization patterns (Beat/Pop/Clear)
- ◆ ACS (Active Clear Sound)
- ◆ Digital tuner with auto preset
- ◆ 15 AM/30 FM station memory
- ◆ 1-bit D/A converter
- ◆ Program (20 tracks)/repeat/random play
- ◆ CD synchro-start recording
- ◆ Clock/timer (with sleep and wake-up)
- ◆ PHONES/AC inputs
- ◆ DC input
- ◆ Remote control case provided on shoulder strap

The sound generated behind the diaphragm is routed through long, winding labyrinth ducts to outside, to extend the frequency response down to the lowest frequencies. This is another JVC innovation that allows incredibly rich bass from a small package.

RV-B55LTD

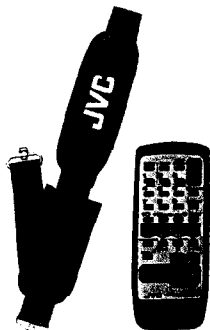
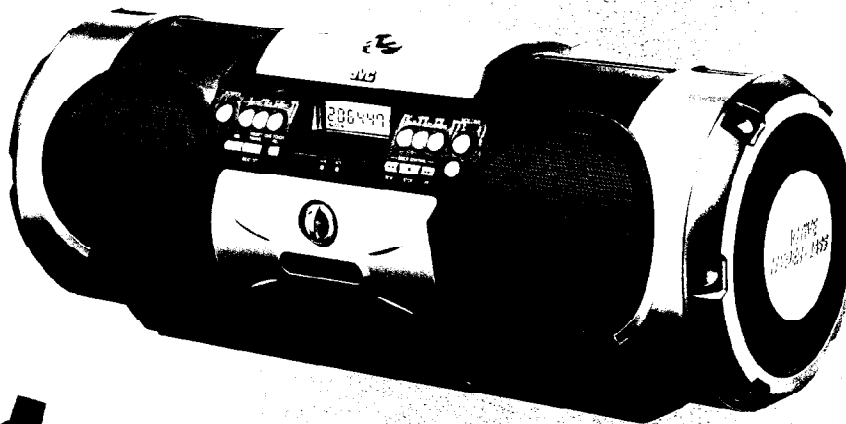

RV-B55GY

RV-B55BU



## RV-B55

CD Portable System

## AHB PRO

- ◆ Active Hyper-Bass PRO (2 steps and OFF)
- ◆ Long labyrinth ducts
- ◆ Rugged tubular construction
- ◆ 12 watts per channel
- ◆ 4-inch (10cm) full-range speaker × 2
- ◆ 4-layer voice coil
- ◆ Full-function remote control

- ◆ Twist auto lock CD and cassette doors
- ◆ Full-logic auto-reverse cassette deck
- ◆ AUX input
- ◆ Backlit LCD
- ◆ 3 preset equalization patterns (Beat/Pop/Clear)
- ◆ ACS (Active Clear Sound)

- ◆ Digital tuner with auto preset
- ◆ 15 AM/30 FM station memory
- ◆ 1-bit D/A converter
- ◆ Program (20 tracks)/repeat/random play
- ◆ CD synchro-start recording
- ◆ Clock/timer (with sleep and wake-up)
- ◆ PHONES/AC inputs

- ◆ DC input
- ◆ Remote control case provided on shoulder strap

# CD PORTABLE SYSTEMS

## PC-XC12

CD Changer  
Portable  
Component System

- ◆ Dual cassette decks
- ◆ 3-CD Triple-Tray changer (Play & Exchange System)
- ◆ Active Hyper-Bass PRO (on/off)
- ◆ Digital tuner with auto preset
- ◆ 1-bit D/A converter

- ◆ 3-CD continuous/program (20 tracks)/repeat/random play
- ◆ 15 AM/15 FM station memory
- ◆ CD synchro-start recording
- ◆ 3 preset equalizations (Beat/Pop/Clear)
- ◆ PHONES/AC inputs
- ◆ 4-inch (10cm) full-range ported speaker
- ◆ Remote control (CD, tuner, power, volume, Active Hyper-Bass PRO)

3-CD  
TRIPLE TRAY

AHB PRO

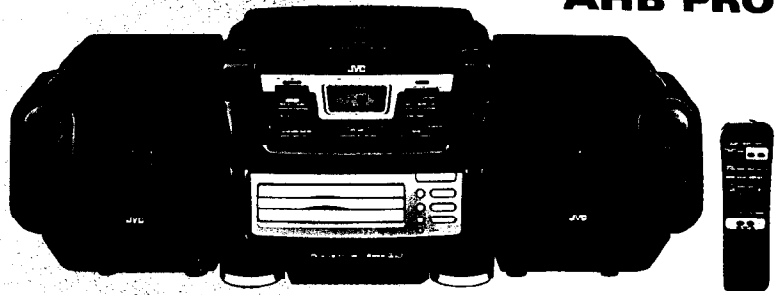

3-CD  
TRIPLE TRAY

AHB PRO

## PC-XC8

CD Changer  
Portable  
Component System

- ◆ 3-CD Triple-Tray changer (Play & Exchange System)
- ◆ Active Hyper-Bass PRO (on/off)
- ◆ Digital tuner with auto preset
- ◆ 1-bit D/A converter

- ◆ 3-CD continuous/program (20 tracks)/repeat/random play
- ◆ 15 AM/15 FM station memory
- ◆ CD synchro-start recording
- ◆ Full auto stop
- ◆ 3 preset equalizations (Beat/Pop/Clear)
- ◆ PHONES/AC inputs
- ◆ 4-inch (10cm) full-range ported speaker
- ◆ Remote control (CD, tuner, power, volume, Active Hyper-Bass PRO)



## PC-X570

CD Portable  
Component System

- ◆ Active Hyper-Bass PRO (on/off)
- ◆ 3 preset equalizations (Beat/Pop/Clear)
- ◆ Backlit LCD
- ◆ Full-function remote control
- ◆ "Feather-touch" full-logic cassette deck
- ◆ 1-bit D/A converter

- ◆ 8-times oversampling digital filter
- ◆ CD program (20 tracks)/repeat/random play
- ◆ Digital tuner with auto preset
- ◆ 15 AM/15 FM station memory
- ◆ Multi-source one-touch recording
- ◆ Sleep timer
- ◆ Full auto stop
- ◆ PHONES/AC inputs
- ◆ 2-way speakers: 4-inch (10cm) + 1 1/8-inch (2cm)

AHB PRO

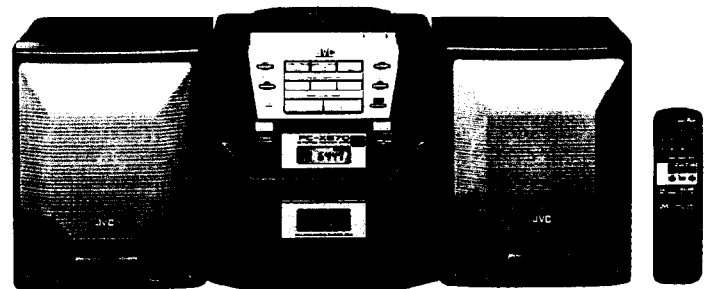

AHB PRO

## PC-X560

CD Portable  
Component System

- ◆ Active Hyper-Bass PRO (on/off)
- ◆ 3 preset equalizations (Beat/Pop/Clear)
- ◆ Full-function remote control
- ◆ "Feather-touch" full-logic cassette deck
- ◆ 1-bit D/A converter

- ◆ 8-times oversampling digital filter
- ◆ CD program (20 tracks)/repeat/random play
- ◆ Digital tuner with auto preset
- ◆ 15 AM/15 FM station memory
- ◆ Multi-source one-touch recording
- ◆ Sleep timer
- ◆ Full auto stop
- ◆ PHONES/AC inputs
- ◆ 4-inch (10cm) full-range speaker





## RC-QN3

### CD Portable System

- ◆ Active Hyper-Bass PRO (on/off)
- ◆ Auto-reverse cassette deck
- ◆ Backlit LCD
- ◆ Kaleido-Clock display
- ◆ Multi Jog Control (Clock/timer, Volume)
- ◆ Power bass-reflex ducts
- ◆ Digital tuner with auto preset
- ◆ See-through top cover
- ◆ Remote control
- ◆ COMPU PLAY
- ◆ 3 preset equalizations (Beat/Pop/Clear)
- ◆ 1-bit D/A converter
- ◆ CD synchro-start recording
- ◆ CD repeat play
- ◆ 15 AM/15 FM station memory
- ◆ PHONES/AC inputs
- ◆ 4-inch (10cm) speaker x 2

## AHB PRO



## RC-QN2

### CD Portable System

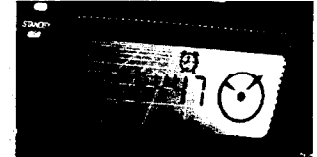

Kaleido-Clock Display with Lively Animation (RC-QN3/RC-QN2)

## AHB PRO

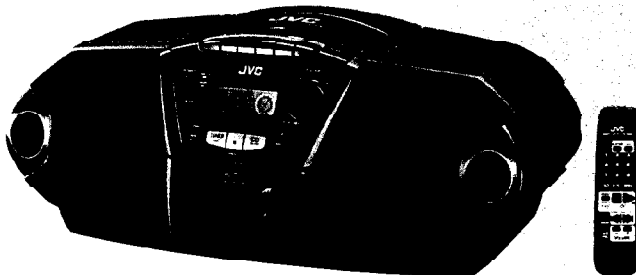

- ◆ Active Hyper-Bass PRO (on/off)
- ◆ Backlit LCD
- ◆ Kaleido-Clock display
- ◆ Multi Jog Control (Clock/timer, Volume)
- ◆ Power bass-reflex ducts
- ◆ Digital tuner with auto preset
- ◆ See-through top cover
- ◆ Remote control
- ◆ COMPU PLAY
- ◆ 3 preset equalizations (Beat/Pop/Clear)
- ◆ 1-bit D/A converter
- ◆ CD synchro-start recording
- ◆ CD repeat play
- ◆ 15 AM/15 FM station memory
- ◆ Full auto stop
- ◆ PHONES/AC inputs
- ◆ 4-inch (10cm) speaker x 2

## RC-QN1

### CD Portable System

- ◆ Digital tuner with auto preset
- ◆ Remote control
- ◆ 3 preset equalizations (Beat/Pop/Clear)
- ◆ Power bass-reflex ducts
- ◆ COMPU PLAY
- ◆ 1-bit D/A converter
- ◆ CD synchro-start recording
- ◆ CD repeat play
- ◆ Full auto stop
- ◆ 15 AM/15 FM station memory
- ◆ PHONES/AC inputs
- ◆ 4-inch (10cm) speaker x 2

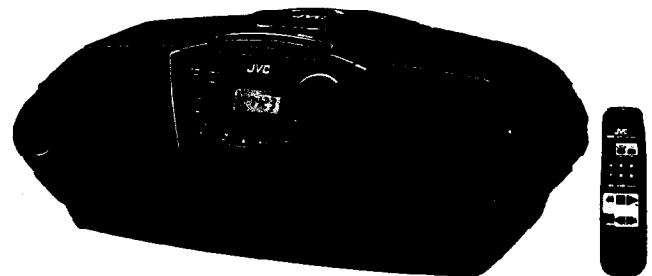

## RC-BX25

### CD Portable System



- ◆ CD remote control
- ◆ COMPU PLAY
- ◆ 1-bit D/A converter
- ◆ CD synchro-start recording
- ◆ Bass boost
- ◆ Repeat play
- ◆ AM/FM tuner
- ◆ Tone control
- ◆ PHONES/AC inputs
- ◆ ALC (Automatic Level Control)

P A B L O



... sound—  
... here, anytime.  
**A full line of portable MD players  
and CD players developed  
in-house by JVC.**



## PORTABLE MD PLAYERS

### ACB (Active Clear Bass)

ACB gives you crisp lows and clear, wide-range response irrespective of volume levels. The boost circuit is controlled according to the detected output level, ensuring low distortion, even at high volume. Low frequencies, centered at about 70Hz, are boosted without degrading clarity in the mid and high ranges. Yet ultra low frequencies are not boosted unnecessarily, minimizing distortion and impurity.

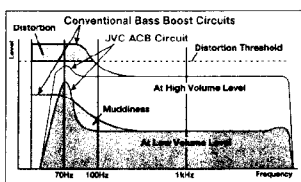

### Jog control editing

The XM-R70 is an MD recorder/player that lets you record live mic sound, an analog line source or a digital source. It's easy to edit recorded tracks thanks to the jog dial and oversized display. Just turn and click the dial to join, divide, shuffle, erase and name tracks.

### LCD remote control with jog

The on-cable remote for JVC

Portable MD Players features a jog dial that lets you adjust volume control and choose tracks with the tip of your finger. A large backlit LCD conveniently shows disc track titles (up to ten characters) of the MD in play.



Remote Control for XM-P55/XM-PJ1

### 40-Second Anti-Shock Memory

A shock or jolt won't cause breaks in your music. During playback, forty seconds of music are constantly stored in memory. When a jolt affects playback, the stored music is recalled from the memory to ensure interruption-free playback.

### Long play time

JVC Portable MD Players keep the music coming for hours on end. The XM-R70 runs for up to 30 hours, and the XM-P55 and XM-PJ1 for up to 16 hours, on the built-in rechargeable battery and an optional alkaline battery. With the XM-PJ1, the optional battery

can be housed inside; no external battery case is required.

### Slim and lightweight (XM-P55)

Nearly the size of an MD jacket, the XM-P55 is a slim and lightweight design.



### Push & Eject (XM-PJ1)

You can change discs quickly. At the touch of a button on the side, the MD container is pushed out as the loaded disc pops out.



## PORTABLE CD PLAYERS

### Triple Shock Protection Version 3.0

● **40-Second Shockproof Memory:** The newly-developed one-chip IC combines 40-second memory with the "defrag" LSI. When a jolt causes pickup mistracking, the memory stores the music in fragments. The LSI then "defrags" the music and sends it out in the correct order to the D/A converter. JVC Portable CD Players are practically shock-proof.

● **High-Speed Pickup Servo:** When mistracking occurs, the High-Speed Servo moves the pickup quickly back to its original position. The latest Version 3.0 makes the pickup highly resistant to vibrations from not only directions (1) and (2) but also direction (3). (See the figure at right)

● **Dynamic Suspension System:** Contoured butyl rubber dampers and springs protect the pickup from shocks and vibrations.

### High-Speed Pickup Servo

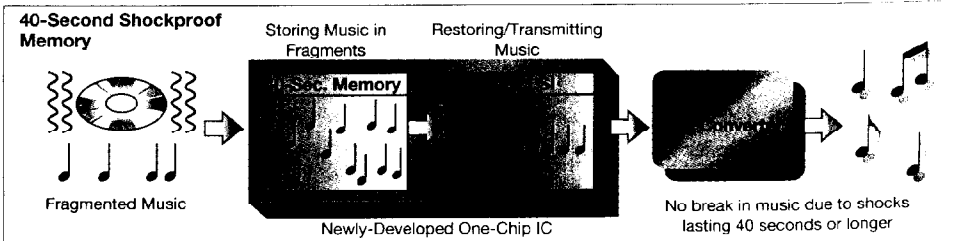
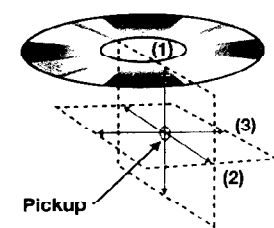

# PORTABLE MD RECORDER/PLAYERS

## XM-R70

### Portable MD Recorder

- ◆ Easy editing with side jog and large display
  - ◆ 5-mode edit functions (Join/Divide/Move/Erase/Title)
  - ◆ Sampling rate converter (32kHz/44.1kHz/48kHz)
  - ◆ Long 9-hour playback/5-hour recording with rechargeable battery\*
  - ◆ Extra-long 30-hour playback (with rechargeable and alkaline batteries)\*
  - ◆ 40-second Shock Protection
  - ◆ Remote control with backlit LCD
  - ◆ Digital synchro recording
- ◆ Mic and line (analog/digital) inputs
  - ◆ ACB (Active Clear Bass)
  - ◆ Random/repeat play
  - ◆ Hold switch
  - ◆ PHONES/DC inputs
  - ◆ Rechargeable lithium ion battery/AC adaptor/external battery case/headphones/remote control/carrying case provided
  - ◆ Slim, compact and lightweight

\* Exact recording and playback times are not final.

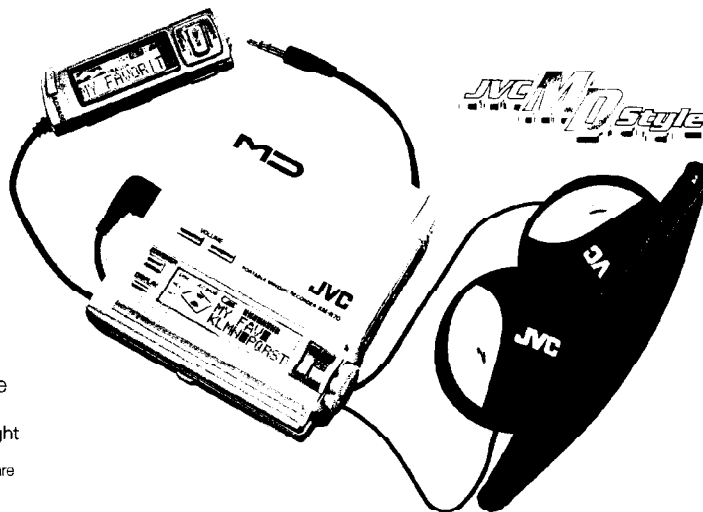

JVC MD Style

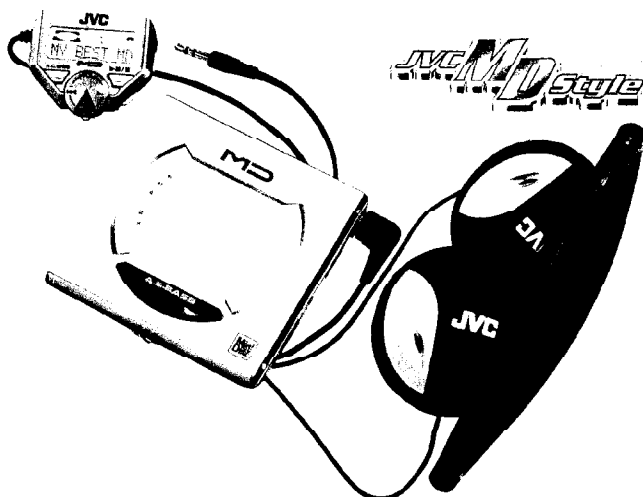

JVC MD Style

## XM-P55

### Portable MD Player



- ◆ Slim and lightweight: 4.5 oz. (128g) (with rechargeable battery)
  - ◆ Compact dimensions (W×H×D): 3<sup>3</sup>/<sub>16</sub>-inch × 1<sup>11</sup>/<sub>16</sub>-inch × 3<sup>3</sup>/<sub>16</sub>-inch (84.4mm × 16.6mm × 80.1mm)
  - ◆ Long 16-hour playback (with rechargeable and alkaline batteries)
  - ◆ 40-second Shock Protection
  - ◆ Remote control with Jog control and 10-character backlit LCD
  - ◆ ACB (Active Clear Bass)
  - ◆ Random/repeat play
- ◆ Hold switch
  - ◆ Short time recharging (Approx. 1.5 hours)
  - ◆ PHONES/DC inputs
  - ◆ Rechargeable battery/AC adaptor/headphones/remote control/carrying case provided

## XM-PJ1

### Portable MD Player



- ◆ Push & Eject mechanism
  - ◆ Eject lock
  - ◆ Convenience with rechargeable and optional alkaline batteries housed inside
  - ◆ Long 16-hour playback (with rechargeable and alkaline batteries)
  - ◆ 40-second Shock Protection
  - ◆ Remote control with Jog control and 10-character backlit LCD
  - ◆ Slim, compact and lightweight
  - ◆ ACB (Active Clear Bass)
  - ◆ Random/repeat play
  - ◆ Hold switch
- ◆ Short time recharging (Approx. 1.5 hours)
  - ◆ PHONES/DC inputs
  - ◆ Rechargeable battery/AC adaptor/charger/headphones/remote control/carrying case provided

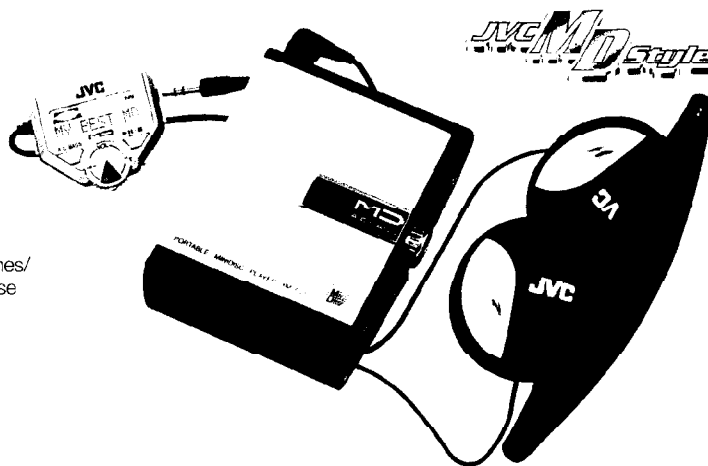

JVC MD Style

# PORTABLE CD PLAYERS

## XL-PV700

Portable CD Player

- ◆ Car and cassette adaptors included
- ◆ Long 48-hour playback (with alkaline batteries, T.S.P. on)
- ◆ 40-second Triple Shock Protection Version 3.0
- ◆ 3-key remote control
- ◆ Hyper-Bass Sound (on/off)
- ◆ Optical digital output
- ◆ "Live Sound" (on/off)
- ◆ 1-bit D/A converter
- ◆ Program (24 tracks)/repeat/random play
- ◆ Resume play
- ◆ Heat-resistant casing
- ◆ Auto power-off
- ◆ Hold switch
- ◆ Short time recharging (Approx. 1.5 hours)
- ◆ PHONES/DC inputs
- ◆ Rechargeable battery/external battery case/AC adaptor/headphones/remote control provided

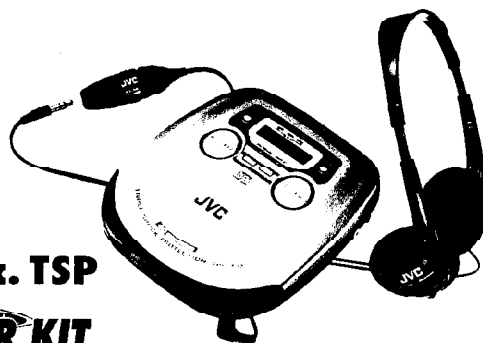

**40 Sec. TSP**



**40 Sec. TSP**

## XL-PG7

Portable CD Player

- ◆ Long 48-hour playback (with alkaline batteries, T.S.P. on)
- ◆ 40-second Triple Shock Protection Version 3.0
- ◆ 3-key remote control
- ◆ Hyper-Bass Sound (on/off)
- ◆ Optical digital output
- ◆ "Live Sound" (on/off)
- ◆ 1-bit D/A converter
- ◆ Program (24 tracks)/repeat/random play
- ◆ Resume play
- ◆ Heat-resistant casing
- ◆ Auto power-off
- ◆ Hold switch
- ◆ Short time recharging (Approx. 1.5 hours)
- ◆ PHONES/DC inputs
- ◆ Rechargeable battery/external battery case/AC adaptor/headphones/remote control provided

## XL-PG5

Portable CD Player

- ◆ 40-second Triple Shock Protection Version 3.0
- ◆ 3-key remote control
- ◆ Hyper-Bass Sound (on/off)
- ◆ Long 46-hour playback (with alkaline batteries, T.S.P. on)
- ◆ 1-bit D/A converter
- ◆ Program (24 tracks)/repeat/random play
- ◆ Heat-resistant casing
- ◆ Resume play
- ◆ Auto power-off
- ◆ Hold switch
- ◆ Short time recharging
- ◆ PHONES/DC inputs
- ◆ Rechargeable battery/external battery case/AC adaptor/headphones/remote control provided



**40 Sec. TSP**

## XL-PV400

Portable CD Player

**40 Sec. TSP**



- ◆ Car and cassette adaptors included
- ◆ 40-second Triple Shock Protection Version 3.0
- ◆ Hyper Bass Sound (on/off)
- ◆ Backlit LCD\*
- ◆ Long 21-hour playback (with alkaline batteries, T.S.P. on)
- ◆ 1-bit D/A converter
- ◆ Program (24 tracks)/repeat/random play
- ◆ Heat-resistant casing
- ◆ Resume play
- ◆ Auto power-off
- ◆ Hold switch
- ◆ PHONES/DC inputs
- ◆ AC adaptor/headphones provided



## XL-PG4

Portable CD Player

**40 Sec. TSP**

- ◆ 40-second Triple Shock Protection Version 3.0
- ◆ Hyper-Bass Sound (on/off)
- ◆ Long 21-hour playback (with alkaline batteries, T.S.P. on)
- ◆ 1-bit D/A converter
- ◆ Program (24 tracks)/repeat/random play
- ◆ Heat-resistant casing
- ◆ Resume play
- ◆ Auto power-off
- ◆ Hold switch
- ◆ PHONES/DC inputs
- ◆ AC adaptor/headphones provided



\* When power is supplied via DC IN jack or with AC adaptor

# SPECIFICATIONS

		MX-WMD90	MX-MD70	MX-J70	MXJ50	MX-J30	MX-J10
		CA-WMD90 Receiver/ 3CD/3-1MD Changer	CA-MD70 Receiver/ 3CD Changer/1MD Recorder	CA-MXJ70 Double Cassette Receiver/ 3CD Triple Tray Changer	CA-MXJ50 Double Cassette Receiver/ 3CD Triple Tray Changer	CA-MXJ30 Double Cassette Receiver/ 3CD Triple Tray Changer	CA-MXJ10 Double Cassette Receiver/ 3CD Triple Tray Changer
<b>AMPLIFIER SECTION</b>							
Output Power:	Front	50 watts per channel, min. RMS, driven into 6 ohms, at 1kHz, with no more than 3% total harmonic distortion	50 watts per channel, min. RMS, driven into 6 ohms, at 1kHz, with no more than 3% total harmonic distortion	120 watts per channel, min. RMS, driven into 6 ohms, at 1kHz, with no more than 10% total harmonic distortion	120 watts per channel, min. RMS, driven into 6 ohms, at 1kHz, with no more than 10% total harmonic distortion	100 watts per channel, min. RMS, driven into 6 ohms, at 1kHz, with no more than 10% total harmonic distortion	60 watts per channel, min. RMS, driven into 6 ohms, at 1kHz, with no more than 10% total harmonic distortion
	Center			30 watts, min. RMS, driven into 8 ohms, at 1kHz, with no more than 0.9% total harmonic distortion			
	Rear			15 watts per channel, min. RMS, driven into 16 ohms, at 1kHz, with no more than 0.9% total harmonic distortion			
Total Harmonic Distortion		0.07% (1kHz)	0.07% (1kHz)	0.05% (1kHz)	0.05% (1kHz)	0.05% (1kHz)	0.07% (1kHz)
<b>CASSETTE DECK SECTION</b>							
Frequency Response				50 — 14,000Hz (Chrome) 50 — 14,000Hz (Normal)	50 — 14,000Hz (Chrome) 50 — 14,000Hz (Normal)	50 — 14,000Hz (Chrome) 50 — 14,000Hz (Normal)	50 — 14,000Hz (Chrome) 50 — 14,000Hz (Normal)
Signal-to-Noise Ratio				57dB* (Chrome)	57dB* (Chrome)	57dB* (Chrome)	57dB* (Chrome)
Wow and Flutter				0.15% (WRMS)	0.15% (WRMS)	0.15% (WRMS)	0.15% (WRMS)
<b>MD DECK SECTION</b>							
Sampling Frequency		32kHz/44.1kHz/48kHz	32kHz/44.1kHz/48kHz				
Data Compression		ATRAC	ATRAC				
<b>CD CHANGER SECTION</b>							
Dynamic Range		92dB	92dB	85dB	85dB	85dB	85dB
Signal-to-Noise Ratio		100dB	100dB	90dB	90dB	90dB	90dB
Total Harmonic Distortion		0.020%	0.009%	0.01%	0.01%	0.01%	0.01%
<b>TUNER SECTION</b>							
Barbits		FM/AM	FM/AM	FM/AM	FM/AM	FM/AM	FM/AM
Dimensions (W x H x D)		9 1/16 x 13 5/8 x 13 3/4 inches 245 x 345 x 348 mm	9 1/16 x 11 1/16 x 13 3/8 inches 245 x 280 x 346 mm	10 7/16 x 12 7/16 x 13 3/8 inches 265 x 315 x 341 mm	10 7/16 x 12 7/16 x 13 3/8 inches 265 x 315 x 341 mm	10 7/16 x 12 7/16 x 13 3/8 inches 265 x 315 x 341 mm	10 7/16 x 11 3/8 x 14 1/4 inches 265 x 295 x 361 mm
Weight		21.6 lbs (9.8 kg)	17.4 lbs (7.9 kg)	20.9 lbs (9.5 kg)	20.7 lbs (9.4 kg)	18.3 lbs (8.3 kg)	17.7 lbs (8 kg)
Type		<b>SP-WMD90 Speaker System</b> 3-way, 4-speaker, bass-reflex, Dual Cannon Duct System, magnetically shielded	<b>SP-MD70 Speaker System</b> 3-way, 3-speaker, bass-reflex, Dual Cannon Duct System, magnetically shielded	<b>SP-MXJ77 Speaker System</b> 3-way, 3-speaker, bass-reflex, Dual Cannon Duct System, magnetically shielded	<b>SP-MXJ50 Speaker System</b> 4-way, 4-speaker, bass-reflex, Labyrinth Port Speaker System	<b>SP-MXJ30 Speaker System</b> 2-way, 2-speaker, bass-reflex, Dual Duct System	<b>SP-MXJ10 Speaker System</b> 2-way, 2-speaker, bass-reflex, Dual Duct System
Speakers:	Woofer	3 1/8-inch (10cm) cone	5 7/8-inch (13.5cm) cone	5 7/8-inch (10cm) cone	5 7/8-inch (10cm) cone	5 7/8-inch (10cm) cone	4 7/8-inch (12cm) cone
	Midrange	2 3/8-inch (6cm) and 2-inch (5cm) cones	2-inch (5cm) cone	2-inch (5cm) cone	2-inch (5cm) cone	2-inch (5cm) cone	2-inch (5cm) cone
	Tweeter	1 3/8-inch (2cm) dome	1 3/8-inch (1.5cm) dome	1 3/8-inch (2cm) dome	1 3/8-inch (4cm) cone Supertweeter: 1 3/8-inch (2cm) dome	2-inch (5cm) dome	2-inch (5cm) cone
Power Handling Capacity		50 watts	50 watts	120 watts	120 watts	100 watts	60 watts
Impedance		6 ohms	6 ohms	6 ohms	6 ohms	6 ohms	6 ohms
Dimensions (W x H x D)		8 5/8 x 13 5/8 x 10 1/8 inches 210 x 345 x 266 mm	7 1/2 x 11 1/16 x 9 7/16 inches 190 x 280 x 239 mm	8 1/2 x 12 7/16 x 10 3/4 inches 215 x 315 x 273 mm	8 1/2 x 12 7/16 x 10 3/4 inches 215 x 315 x 273 mm	8 1/2 x 12 7/16 x 9 7/16 inches 215 x 315 x 230 mm	8 1/8 x 11 3/8 x 8 7/8 inches 206 x 295 x 225 mm
Weight		8.4 lbs (3.8 kg)	6.2 lbs (2.8 kg)	7.8 lbs (3.5 kg)	8.6 lbs (3.9 kg)	7.3 lbs (3.3 kg)	8.2 lbs (3.7 kg)
<b>SP-DS99SL Center &amp; Surround Speakers</b>							
<b>CENTER SPEAKER</b>							
Type				Bass-reflex, magnetically shielded			
Speaker				3 7/8-inch (8cm) cone			
Power Handling Capacity				30 watts			
Impedance				8 ohms			
Dimensions (W x H x D)				9 1/16 x 4 3/4 x 5 3/4 inches 245 x 110 x 145 mm			
Weight				1.8 lbs (0.8 kg)			
<b>SURROUND SPEAKER</b>							
Type				Bass reflex			
Speaker				3 7/8-inch (8cm) cone			
Power Handling Capacity				30 watts			
Impedance				16 ohms			
Dimensions (W x H x D)				6 5/8 x 4 3/8 x 5 3/8 inches 160 x 110 x 136 mm			
Weight				1.3 lbs (0.6 kg)			

\*Measured at peak level, weighted, without Dolby NR.

	FS-V9MD	FS-V5
<b>AMPLIFIER SECTION</b>		
Output Power	17 watts per channel, min. RMS, at 4 ohms, from 80Hz to 20kHz, with no more than 10% total harmonic distortion	16 watts per channel, min. RMS, at 4 ohms, from 80Hz to 20kHz, with no more than 10% total harmonic distortion
<b>MD DECK SECTION</b>		
Sampling Frequency	32kHz/44.1kHz/48kHz	
Data Compression	ATRAC	
<b>CD PLAYER SECTION</b>		
Dynamic Range (1kHz)	85dB	85dB
Signal-to-Noise Ratio	90dB	90dB
<b>CASSETTE DECK SECTION</b>		
Frequency Response	60 — 15,000Hz (Chrome)	
Signal-to-Noise Ratio	52dB* (Chrome)	
Wow and Flutter	0.15% (WRMS)	
<b>TUNER SECTION</b>		
Bands	FM/AM	FM/AM
Dimensions (W x H x D)	6 1/4 x 9 1/8 x 12 1/4 inches 158 x 231 x 310.5 mm	6 1/4 x 9 1/8 x 12 1/4 inches 158 x 232 x 310.5 mm
Weight	9.1 lbs (4.1 kg)	7.7 lbs (3.5 kg)
<b>SPEAKER SECTION</b>		
Type	Bass-reflex	Bass-reflex
Speakers	Woofer: 3 7/8-inch (9cm) cone Tweeter: 1 1/8-inch (4cm) cone	Full-range: 3 7/8-inch (9cm) cone
Impedance	4 ohms	4 ohms
Dimensions (W x H x D)	5 7/8 x 9 1/8 x 8 5/8 inches 140 x 230 x 216 mm	5 7/8 x 9 1/8 x 8 5/8 inches 140 x 230 x 217 mm
Weight	4.0 lbs (1.9 kg)	3.9 lbs (1.8 kg)

\* Measured at peak level, weighted, without NR.

	RV-B99	RV-B55
<b>Bands</b>		
	FM/AM	FM/AM
Power Source:	AC DC	120V, 60Hz D (13F) x 10"
Speakers:	Full-range Subwoofer	3 7/8-inch (9cm) x 2 6 1/2-inch (16cm) x 2
Power Output:	Full-range Subwoofer	6 watts per channel, min. RMS, at 4 ohms, from 150Hz to 15kHz 20 watts per channel, min. RMS, at 4 ohms, at 60Hz
Dimensions (W x H x D)	27 1/8 x 9 7/8 x 11 1/8 inches 690 x 239 x 296 mm	21 3/8 x 8 7/8 x 10 1/4 inches 542 x 216 x 260 mm
Weight (without batteries)	2.1 lbs (9.5 kg)	13.0 lbs (6.1 kg)

\* Car battery available with optional CA-R120 or CA-R150 car battery adaptor

	XM-R70	XM-P55	XM-PJ1
Power Source:	AC DC	120V, 60Hz (AC adaptor) 15A x 3	120V, 60Hz (AC adaptor) 15A x 1
Power Output:	Headphones	5mW x 2, at 10% THD, 16 ohms	5mW x 2, at 10% THD, 16 ohms
Dimensions (W x H x D)	3 7/8 x 1 3/8 x 3 3/8 inches 63.2 x 19.3 x 91 mm	3 7/8 x 1 1/8 x 3 7/8 inches 64.4 x 16.0 x 96.1 mm	3 7/8 x 1 3/8 x 4 1/8 inches 62.9 x 20 x 103 mm
Weight (without batteries)	5.2 oz (147g)	3.6 oz (103g)	4.4 oz (124g)

	PC-XC12	PC-XC8	PC-X570	PC-X560
Bands	FM/AM	FM/AM	FM/AM	FM/AM
Power Source:	AC DC	120V, 60Hz D (13F) x 8	120V, 60Hz D (13F) x 8	120V, 60Hz D (13F) x 8
Speakers	4-inch (10cm)	4-inch (10cm)	4-inch (10cm) + 1 1/8-inch (2cm)	4-inch (10cm)
Power Output (with no more than 10% THD)	6 watts per channel, min. RMS, at 3 ohms, from 150Hz to 15kHz	6 watts per channel, min. RMS, at 3 ohms, from 150Hz to 15kHz	5.5 watts per channel, min. RMS, at 3 ohms, from 150Hz to 15kHz	5.5 watts per channel, min. RMS, at 3 ohms, from 150Hz to 15kHz
Dimensions (W x H x D)	29 1/8 x 10 7/8 x 13 inches 738 x 272 x 330 mm	29 1/8 x 10 7/8 x 13 inches 738 x 272 x 330 mm	24 1/8 x 10 7/8 x 10 9/16 inches 612 x 259 x 263 mm	24 1/8 x 10 7/8 x 10 9/16 inches 612 x 259 x 263 mm
Weight (without batteries)	17.7 lbs (8 kg)	17.2 lbs (7.8 kg)	14.2 lbs (6.4 kg)	14.2 lbs (6.4 kg)

	RC-QN3	RC-QN2	RC-QN1	RC-BX25
Bands	FM/AM	FM/AM	FM/AM	FM/AM
Power Source:	AC DC	120V, 60Hz D (13F) x 8	120V, 60Hz D (13F) x 8	120V, 60Hz D (13F) x 8
Speakers	4-inch (10cm) x 2	4-inch (10cm) x 2	4-inch (10cm) x 2	4-inch (10cm) x 2
Power Output (with no more than 10% THD)	3.6 watts per channel, min. RMS, at 3 ohms, from 150Hz to 15kHz	3.6 watts per channel, min. RMS, at 3 ohms, from 150Hz to 15kHz	3.6 watts per channel, min. RMS, at 3 ohms, from 150Hz to 15kHz	3.4 watts per channel, min. RMS, at 3 ohms, from 150Hz to 15kHz
Dimensions (W x H x D)	18 1/8 x 7 3/8 x 10 inches 480 x 186 x 254 mm	18 1/8 x 7 3/8 x 10 inches 480 x 186 x 254 mm	18 1/8 x 7 3/8 x 10 inches 480 x 186 x 254 mm	16 7/8 x 8 7/8 x 9 1/8 inches 411 x 163 x 254 mm
Weight (without batteries)	9.9 lbs (4.5 kg)	9.3 lbs (4.2 kg)	8.8 lbs (4.0 kg)	7.7 lbs (3.5 kg)

	XL-PV700	XL-PQ7	XL-PQ6	XL-PV400	XL-PQ4
Power Source:	AC DC	120V, 60Hz (AC adaptor) 15F x 2	120V, 60Hz (AC adaptor) 15F x 2	120V, 60Hz (AC adaptor) 15F x 2	120V, 60Hz (AC adaptor) 15F x 2
Power Output:	Headphones	9mW x 2, at 10% THD, 16 ohms	9mW x 2, at 10% THD, 16 ohms	9mW x 2, at 10% THD, 16 ohms	9mW x 2, at 10% THD, 16 ohms
Dimensions (W x H x D)	5 1/8 x 1 3/8 x 5 7/8 inches 128 x 27.9 x 136.1 mm	5 1/8 x 1 3/8 x 5 7/8 inches 128 x 27.9 x 136.1 mm	5 7/8 x 1 3/8 x 5 1/8 inches 128.5 x 28.9 x 144 mm	5 7/8 x 1 3/8 x 5 1/8 inches 128.5 x 28.9 x 144 mm	5 7/8 x 1 3/8 x 5 1/8 inches 128.5 x 28.9 x 144 mm
Weight (without batteries)	9.2 oz (235g)	8.2 oz (235g)	7.8 oz (220g)	7.8 oz (220g)	7.8 oz (220g)

\* Optional

## We Bring the Music to You

**JVC**  
INTERNATIONAL  
**JAZZ**  
FESTIVAL

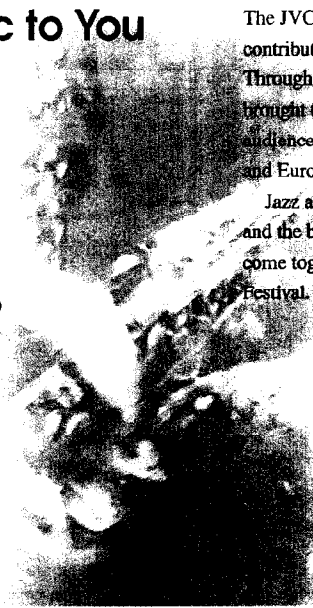

The JVC Jazz Festival is JVC's proud contribution to the world music scene. Through this annual event, JVC has brought the best of live jazz to audiences in both the United States and Europe for the past fourteen years.

Jazz and JVC—the best in music and the best in music reproduction come together at the JVC Jazz Festival. Be sure to join us.



GATO BARRIERI



LENNY WHITE

## JVC—Supporting the Best in Worldwide Entertainment

### JVC is Proud to Support Soccer

As a true "corporate citizen" of the world, JVC is dedicated to community—building activities on a global scale, like promoting the world's sport—soccer.

In the spirit of global citizenship, JVC is proud to support the most international sporting event of all—World Cup soccer. As we have done six consecutive times since 1982, we are now sponsoring the 17th FIFA World Cup that will take place in Japan and Korea in 2002. JVC is proud to support soccer.



©1974 FIFA TM

**JVC**® DISTRIBUTED BY

JVC COMPANY OF AMERICA

1700 Valley Road, Wayne, N.J. 07470

<http://www.jvc.com>

*Design and specifications subject to change.  
The photos of the products featured in this brochure are of actual products that are available.*

Copyright © 1999 Victor Company of Japan, Limited (JVC)