

# **LANEY**

## **THEATRE RANGE POWER AMPLIFIERS**

**TH9600S & TH9360S**

**OPERATING  
MANUAL**

## TH9600S & TH9360S POWER AMPLIFIERS FROM LANEY ELECTRONICS

Laney Electronics have been manufacturers of quality amplifiers for over 20 years, during which there continued appreciation of market requirements has made them a world leader in musical amplification products.

The Theatre range of power amplifiers are representative of Laney's policy to provide professional equipment using the latest available technology yet still remain cost effective to the end user.

An intensive program of research by our well respected R & D team using the latest CAD design facilities, has produced a range of power amplifiers which will stand up to the most demanding of applications whilst providing an almost transparent amplification of audio information.

With all Laney products reliability is a key factor and dependable performance is inherent right from the design stage through to the manufacture, use of proven techniques and a highly skilled work force combine to produce product you can rely on.

Mos-Fet technology provides an absolutely neutral sound quality and eliminates all forms of distortion from an audible point of view. The wide bandwidth, fast slew rate and relatively low amounts of negative feedback guarantee effortless transient performance and exceptional stability.

Because of the inherent thermal stability, protection circuits can be greatly simplified. This allows clean performance into highly reactive loads such as electrostatic loudspeakers or transformers. Laney power amplifiers will deliver high frequency, high power signals without difficulty and stay cool even under the toughest conditions.

To gain maximum benefit from your Laney power amplifier it is essential that you are familiar with all aspects of its operation time out carefully reading this manual is recommended.

### FEATURES

#### POWER MOS-FET OUTPUT STAGE

Delivering low distortion, super fast slew rate and high damping factor.

#### MASSIVE POWER SUPPLY

Toroidal mains transformer together with overrated reservoir capacitors provide stable continuous energy for increased transient performance.

#### MECHANICAL EXCELLENCE

The Theatre range are designed to set high standards in safety, performance and reliability, using proven manufacturing techniques with the latest available technology. All component assemblies are modular for ease of serviceability and reduced down time.

#### MULTIPLE PROTECTION CIRCUITS

High current relay systems protects against short and open circuit, thermal overheat, speaker mismatch and D.C. fault conditions.

#### FAN COOLING

Both amplifiers feature a quiet running 2-speed fan system, for controlled cooling without noisy fan cycling.

#### LED INFORMATION INDICATORS

Display instant status of clip point, thermal condition, load monitor and Bridged/Stereo mode.

#### SOFT START

High current relay system ensures trouble free operation even under adverse mains conditions on the TH9600S.

#### SURGE FREE TURN-ON

High current relay systems provides switch-on delay and instant speaker disconnection upon switch-off, preventing possible speaker damage from excessive cone excursions.

#### COMPREHENSIVE INPUT AND OUTPUT FACILITIES

Parallel XLR and 1/4" stereo jack inputs. XLR and Binding post outputs.

#### EXTERNAL STEREO/MONO SWITCH

Accessible from front with LED status indicator.

#### EARTH LINK SWITCH

Provides separation of "Electrical-Safety Earth" system and "Signal Earth" for minimizing possible hum loops.

#### 19" RACK MOUNTING

Accurate International Rack Standard design means Laney power amps really do stack up in a rack.

CIRCUIT SCHEMATIC A printed block schematic on the top panel shows all inter-connection details for the user.

#### PERFORMANCE GUARANTEE

Every Laney power amplifier undergoes an intensive test procedure to ensure maximum reliability and performance.

## YOUR LANEY POWER AMPLIFIER IN OPERATION

WARNING It is important these amplifiers are earthed.

### CONNECTING UP

A suitable three-pin plug must be fitted and the correct wiring code adhered to in the U.K. for example connections will be as follows.

GREEN/YELLOW	-EARTH
BROWN	-LIVE
BLUE	-NEUTRAL

### POWERFUSE/VOLTAGE SELECTOR

A safety fuse is fitted in a pull out drawer below the power inlet socket. The drawer may be inserted in two ways allowing different supply voltages to be used.

It is important before switch on you check that the voltage indicated by the fuse drawer corresponds to the supply voltage you are using.

In the unlikely event of a fuse failure it is important that a replacement fuse be of the correct type and rating. Failure to comply with this could result in a fire hazard.

### SIGNAL GROUND LINK

The Theatre range of power amplifiers are provided with a Signal Ground Link switch to eliminate possible hum loops.

There are two distinct forms of "earth"

- 1 Signal Earth i.e. the centre tap of the D.C. power supply and amplifier input signal 0 Volts.
- 2 Electrical Safety Earth, Green/yellow wire of mains power cable which is a fixed internal connection to all chassis metalwork for safe operation.

The Signal Ground Link switch at the rear of the amplifier allows you to connect or disconnect the Signal Earth from the Electrical Safety Earth.

For most applications, and particularly if Balanced inputs are being used, hum loops should not arise and the Earth Link should be left switched to the on position.

However, in situations where an amplifier is being used as part of a larger sound system where other devices, e.g. mixers, graphic equalisers etc., are being connected by unbalanced signal lines, the possibility of setting up earth loops resulting in hum, is increased. In these circumstances setting the Signal Ground Link switch to the off position, thus disconnecting "Signal Earth" and "Electrical Safety Earth" will eliminate this problem.

### INPUT ATTENUATORS

Each channel is fitted with a infinitely variable input attenuator, with a calibrated dB scale for guidance.

### INPUT CONNECTIONS

Each channel has a parallel input combination of 1/4" stereo jack or XLR socket, Both are Balanced and wiring is as fig 1.

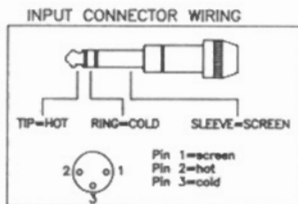

### OUTPUT CONNECTIONS

Each channel has a parallel combination of 1/4" mono jack, XLR and Binding posts, connections are as shown in fig 2.

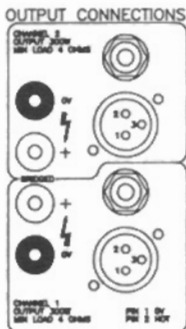

### STEREO BRIDGE SWITCH

Provides two modes of operation

1. stereo mode.
2. mono-bridge mode.

**WARNING** always ensure amplifier is switched off before operating this switch.

### STEREO MODE

Allows both channels to run independently with channel 1 inputs feeding channel 1 outputs and channel 2 inputs feeding channel 2 outputs.

### BRIDGED MONO-MODE

Delivers double the available output power into an 8 ohm load by connecting the load between the + output terminals of each channel and the input to channel 1 only.

Some important rules which must be adhered to when operating in mono/bridge mode.

- 1 Ensure load impedance is not less than 8 ohms.
- 2 Do not ground either side of the output.
- 3 Only use channel 1 input and attenuator.
- 4 Channel 2 input attenuator should be set to zero.

#### FRONT PANEL INDICATORS

There are 7 LED indicators to provide the user with the following information:

PEAK LED 1 per channel illuminates when amplifier output is 1dB below clip point.

THERMAL LED 1 per channel illuminates when the thermal cutout device has operated, The output relay will disconnect the load, the LED will extinguish automatically when the amplifier has returned to its normal operating temperature and the output relay will reconnect the load.

(see also thermal protection)

LOAD LED 1 per channel illuminates if the output relay has disconnected the load for one of the following reasons speaker mismatch, load short or D.C. fault condition.

(see also load protection)

BRIDGE LED illuminates when the stereo/bridge switch is in bridge position.

POWER LED illuminates upon amplifier switch on.

#### PROTECTION

The Theatre range of power amplifiers are protected from excessive overdrive and load impedance mismatch, but the protection circuits will not protect the loudspeakers against excessive power, care must be exercised when selecting loudspeakers.

#### LOAD PROTECTION

All amplifiers are fitted with a high current output relay, which in the unlikely event of D.C. voltages appearing at the output terminals will disconnect the loudspeaker, and the Load LED will illuminate. The output relay will reset once the fault has been rectified.

#### THERMAL PROTECTION

All amplifiers are fitted with two thermal cut-outs which protect the Mos-Fet output devices from overheating. These power amplifiers are designed to deliver the full rated power under the most severe operating conditions. The circumstances most likely to cause overheating are output short circuits or blocked cooling air flow. When a thermal trip operates the output relay disconnects the loudspeaker and the thermal led illuminates, The trip will automatically reset after a short time. It is important to locate and rectify the cause of overheating as quickly as possible.

## INSTALLATION

### FREE STANDING

All units are fitted with rubber feet to enable them to be used as bench standing units.

### RACK MOUNTING

As these amplifiers feature side entry forced air cooling by means of a quiet running two speed fan, any number of amplifiers may be racked together without the need for special ventilation arrangements: the only requirement being that there should be a reasonable free flow of air at the back of the rack housing. For rack mounting of these amplifiers all feet will need to be removed.

## OPERATING PRECAUTIONS

The following guide lines will help prevent potentially expensive 'accidents'

1. Never parallel the output connections.
2. Do not connect the amplifier output(s) to that of any other amplifier.
3. Do not connect the output ground lead to the input signal ground lead.
4. Ensure that the mains input is never more than 10% higher than the selected mains voltage marked on your amplifier.
5. Never remove fuses with power connected.
6. Never use fuses of any other value than the correct rated value.
7. Do not use speakers or transducers that are not adequately rated for the output power of the amplifier. Laney Electronics will not accept any responsibility for damage to any speaker or lead.
8. Ensure that the amplifier has a clear space at the sides of the rack to ensure a free air flow.
9. The amplifier is not recommended for high power use at frequencies above 40Khz.
10. Do not run the amplifier with the top cover removed.
11. Use care in making connections, selecting signal sources, and controlling output level.
12. Never connect the output to a power supply output, battery or power mains. Damage incurred by such a connection is not covered by the warranty.

# BLOCK SCHEMATIC

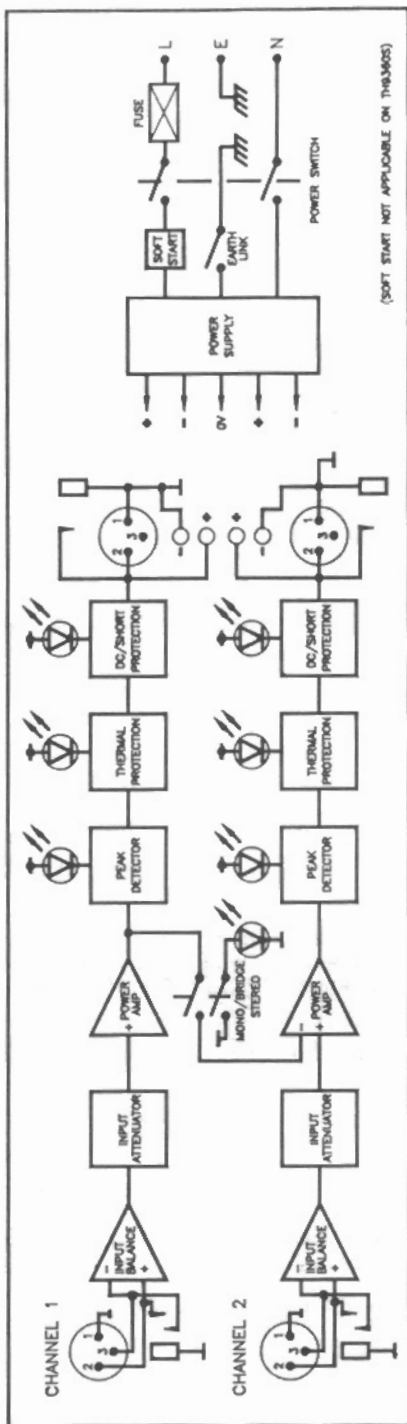





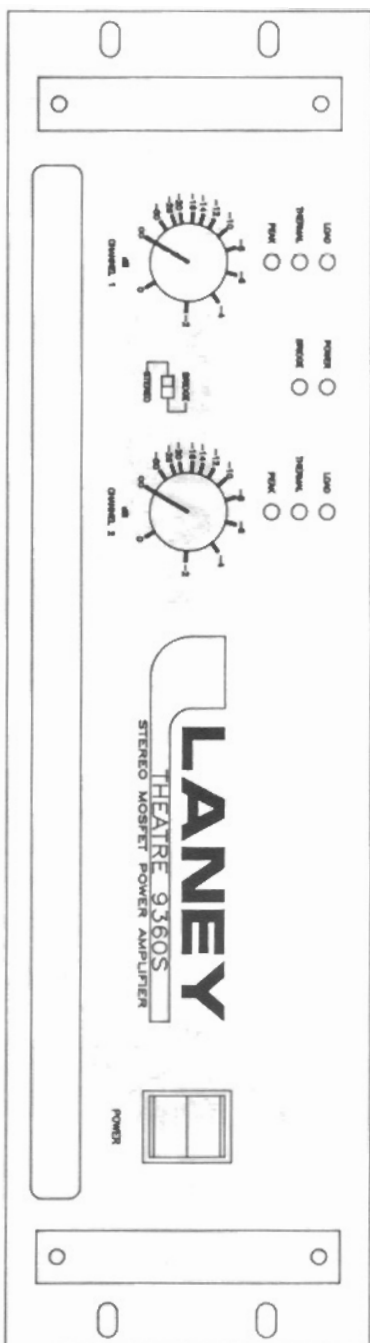
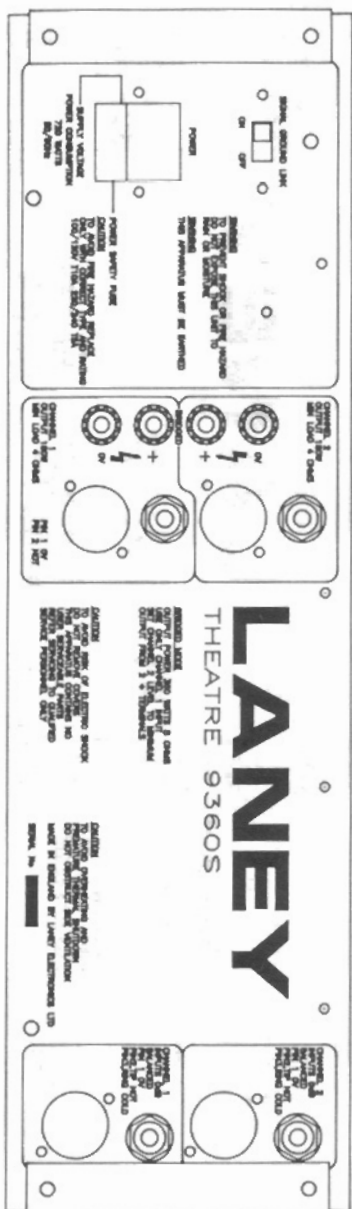

## SPECIFICATIONS

<u>MODEL</u>	<u>TH9360S</u>	<u>TH9600S</u>
Power output at clip point, both channels driven, 1Khz	180Watts, 4ohm 120Watts, 8ohm	300Watts, 4ohm 200Watts, 8ohm
Power output Bridge-mono	360Watts, 8ohm	600Watts, 8ohm
Power Frequency Response	+0dB, -1dB 15hz-20Khz	
T.H.D. @ 1Khz 4ohm load	<0.05%	<0.05%
Input Sensitivity	0.775v for full output	
Input Impedance	10Kohms minimum, Balanced	
C.M.R.R. @ 1Khz	Greater than 60dB	
Hum & Noise	Greater than 100dB	
Channel Separation	Greater than 70dB	
Output Slew Rate	45v/us	
Input Connectors	1 Stereo Jack, 1 Female XLR Per Channel	
Output Connectors	1 Mono Jack, 1 Male XLR 1 Pair Binding Posts Per channel	
Front Panel Indicators	Peak (1dB before clip) Thermal Indicator Load Monitor Bridge/Mono Indicator	
Protection	Thermal Overheat Load Mismatch Short Circuit Open Circuit D.C. Fault	
Cooling	2-Speed Fan	
Power consumption	720Watts	1200Watts
Unit Size	3U	3U

The manufacturers reserve the right to change specification without prior notice.

**LANEY  
ELECTRONICS LTD**

NEWLYN ROAD,  
CRADLEY HEATH,  
WEST MIDLANDS.  
ENGLAND

**LANEY INC**  
1043 SOUTH YORK ROAD,  
SUITE LL6,  
BENSENVILLE,  
ILL.  
USA.