

Elite SCREENS

Fixed Frame Screen

Elite Ez-Frame Series

User's Guide



MATTE WHITE & HIGH CONTRAST GRAY

ASSEMBLING

1. Insert both corner joint connectors into the long (horizontal) frame (see fig.1)

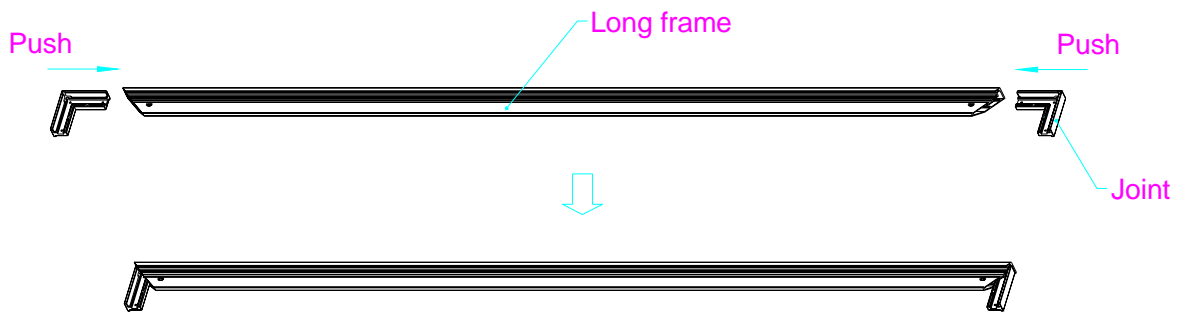

(fig.1)

2. Join all four frame parts together following the steps showed below. (fig.2)

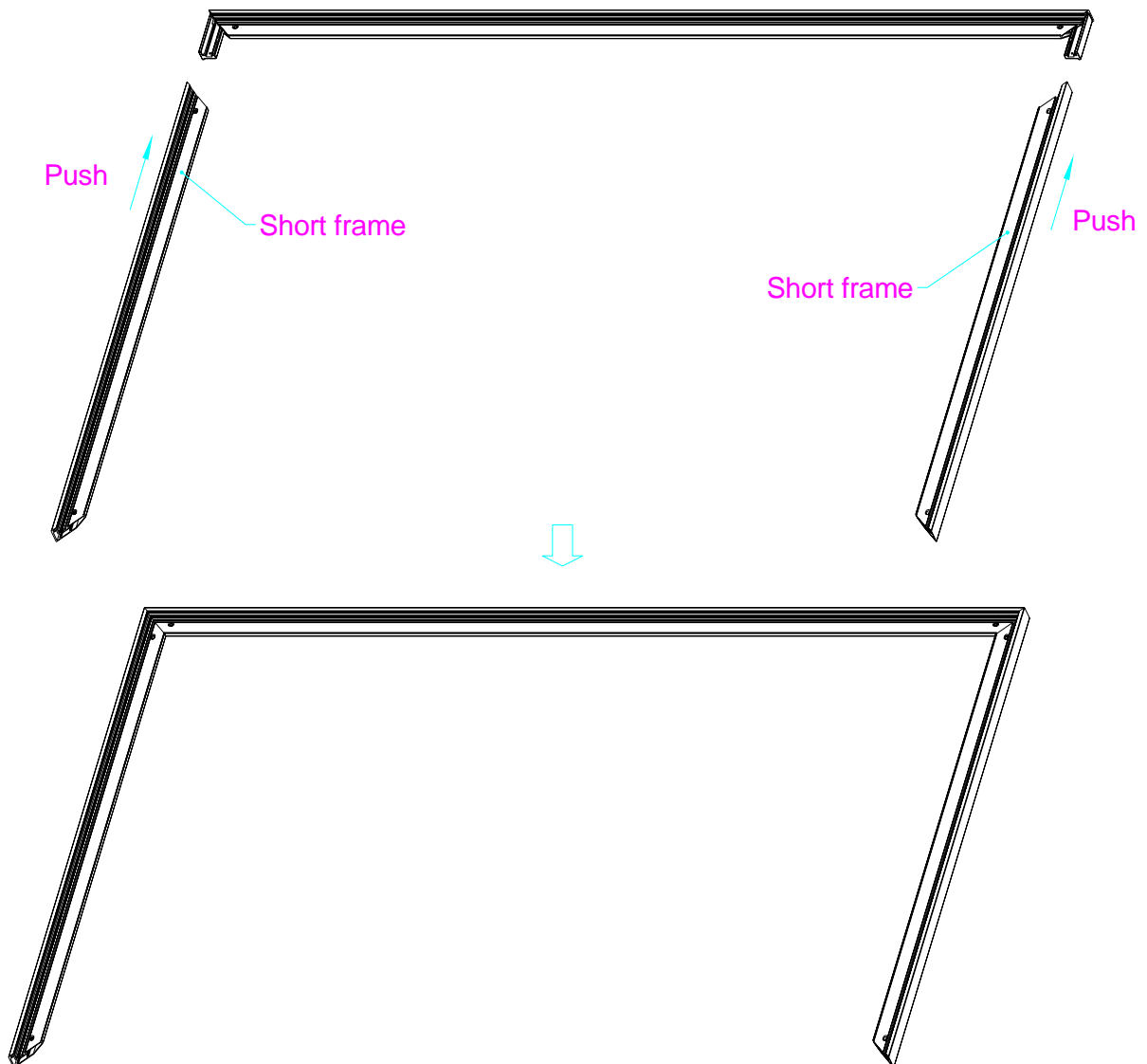

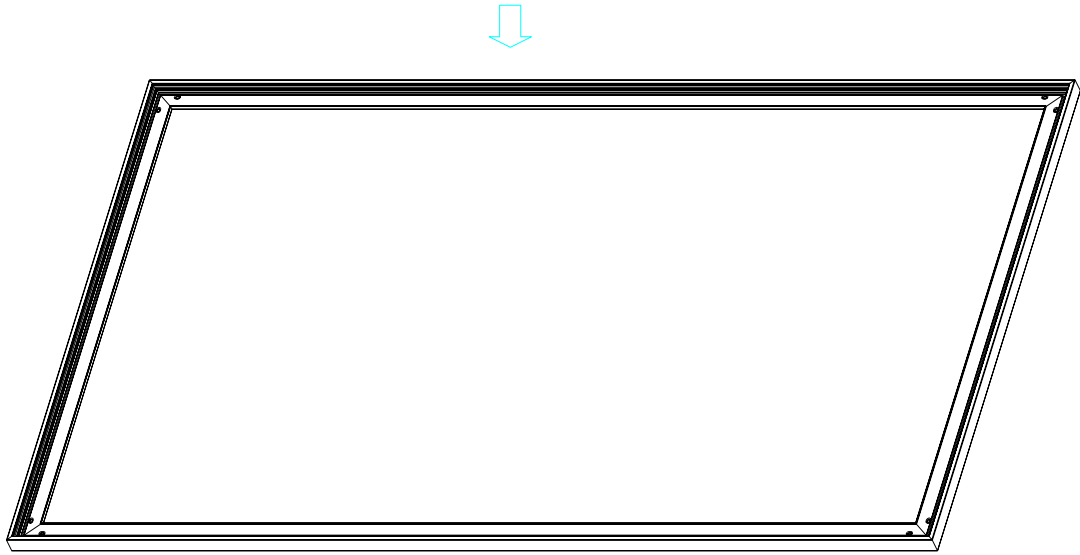
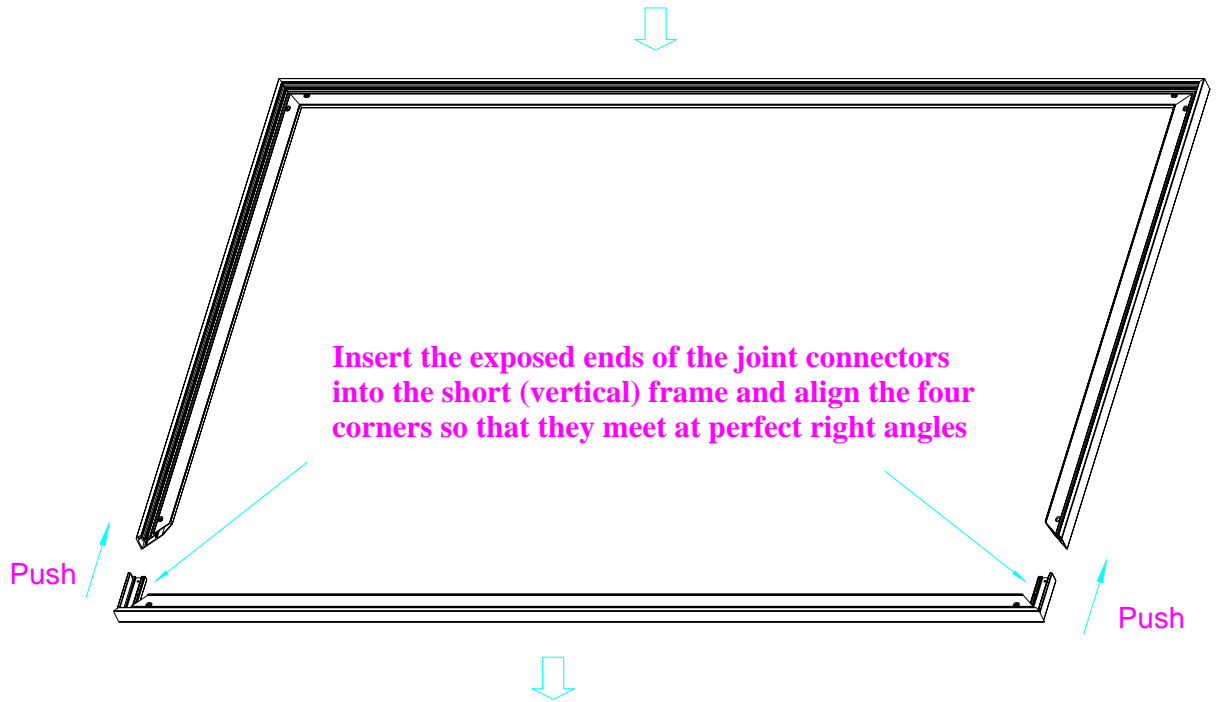

(fig.2)

3. After making sure that all four corners join at right angles to form a perfect rectangle, fasten the four angles together by using the (x8) joint screws included. (see fig.3)

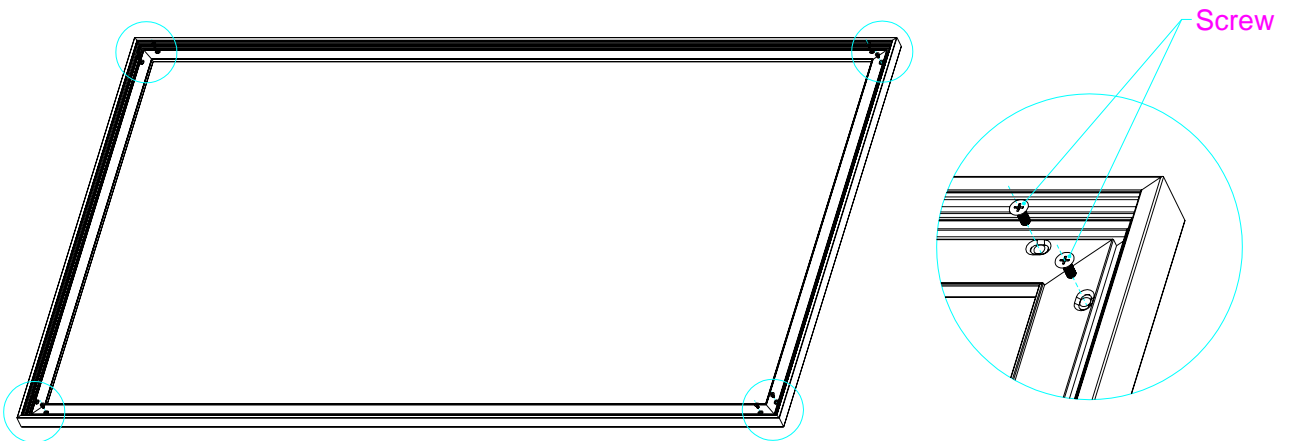

(fig.3)

4. Lay out the screen and tension rods on a clean and dry surface. Pass the screen tension rods through the sleeves according to their corresponding lengths on each edge of the screen as seen below. (see fig.4)

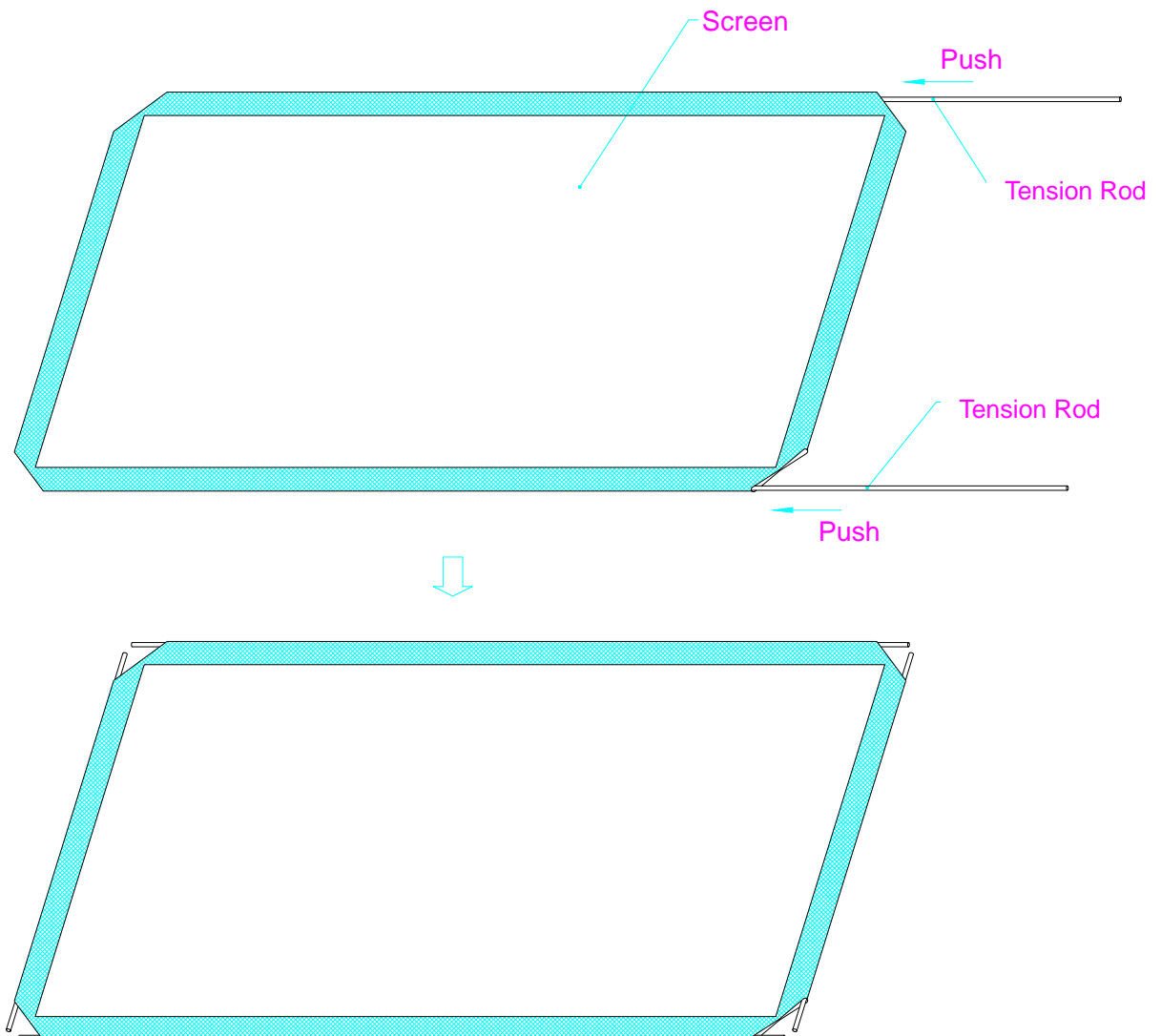

(fig.4)

5. Slip the screen tension rods into the grooves running along each side on the back of the frame. Clip on the fix plates to the back of the frame to secure the rods into place forming a tight and flat surface(see fig5 & fig6)

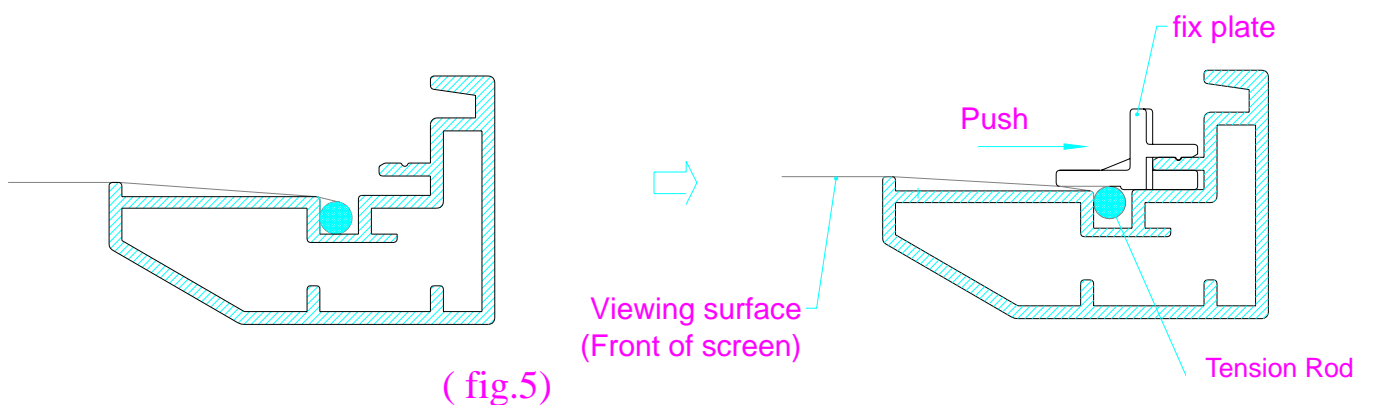

(fig.5)

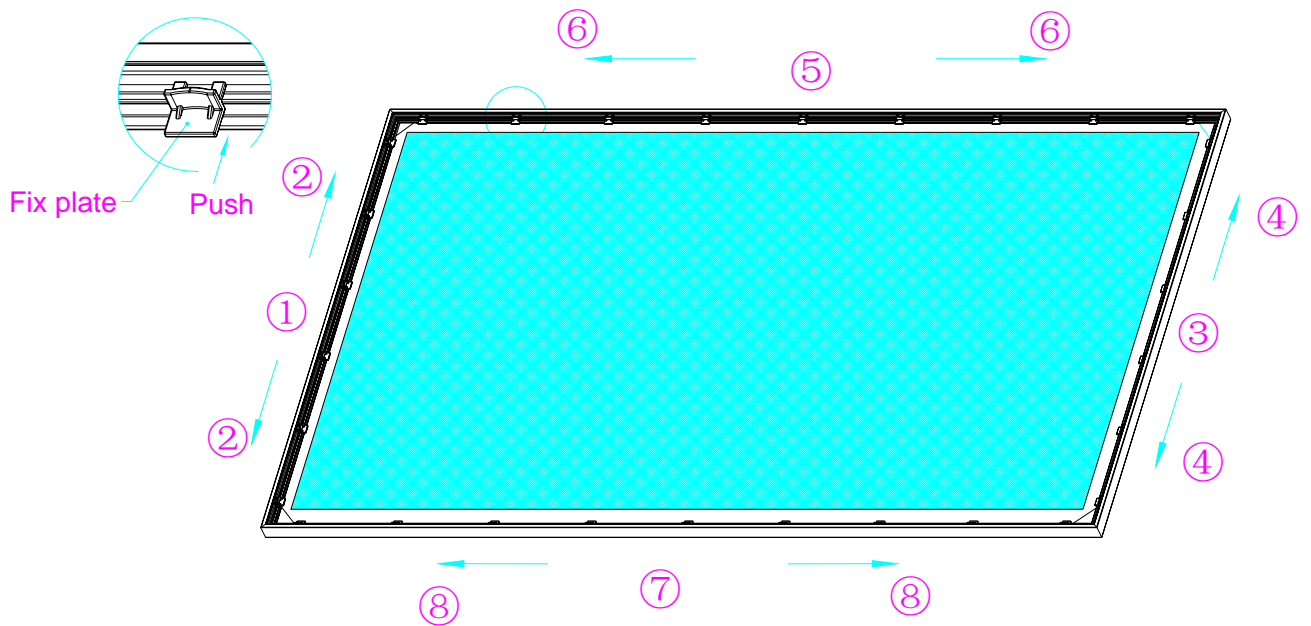

(fig.6) *Note: Numbers 1-8 indicate the recommended order that you should attach your fix plates.

Attaching Fix Plates

1. Start at the left side working toward the right and then from top to bottom of the frame attaching the screen material. Start securing the fix plates at the center of each side working outward (fig.6)
2. Some people prefer to use an alternate method in attaching the fix plates. Start on the left side and then match the opposing sides fix plate piece by piece instead of doing one entire side at a time.

INSTALLATION

Method 1 (smaller than 135" diagonals)

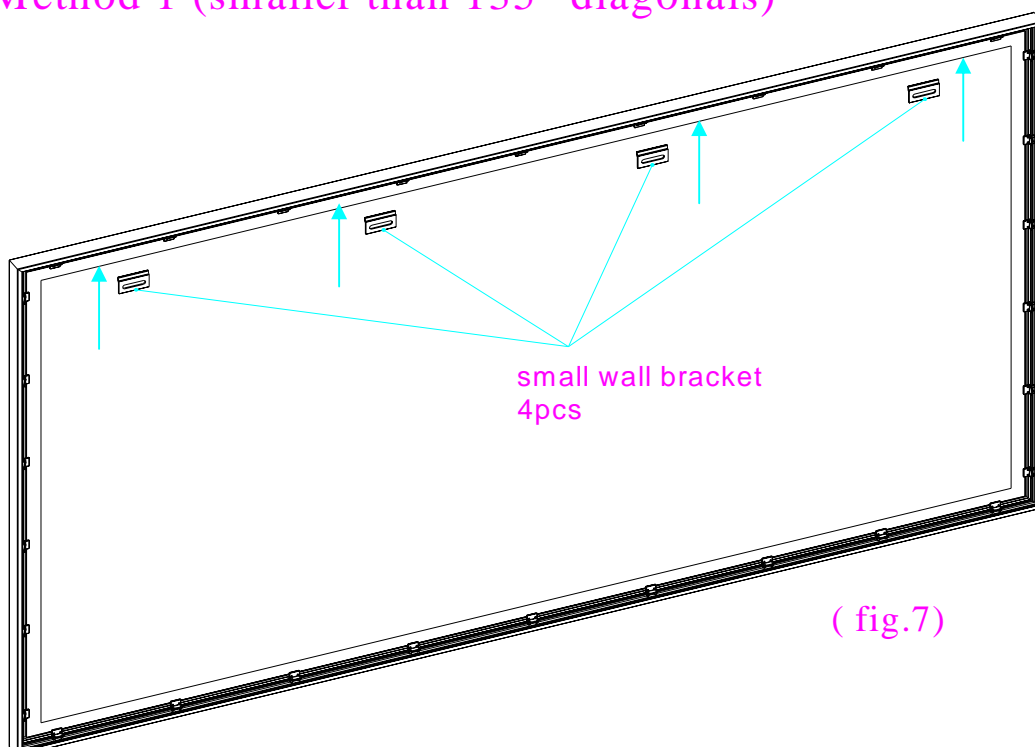

(fig.7)

Method 2 (larger than 135" diagonals)

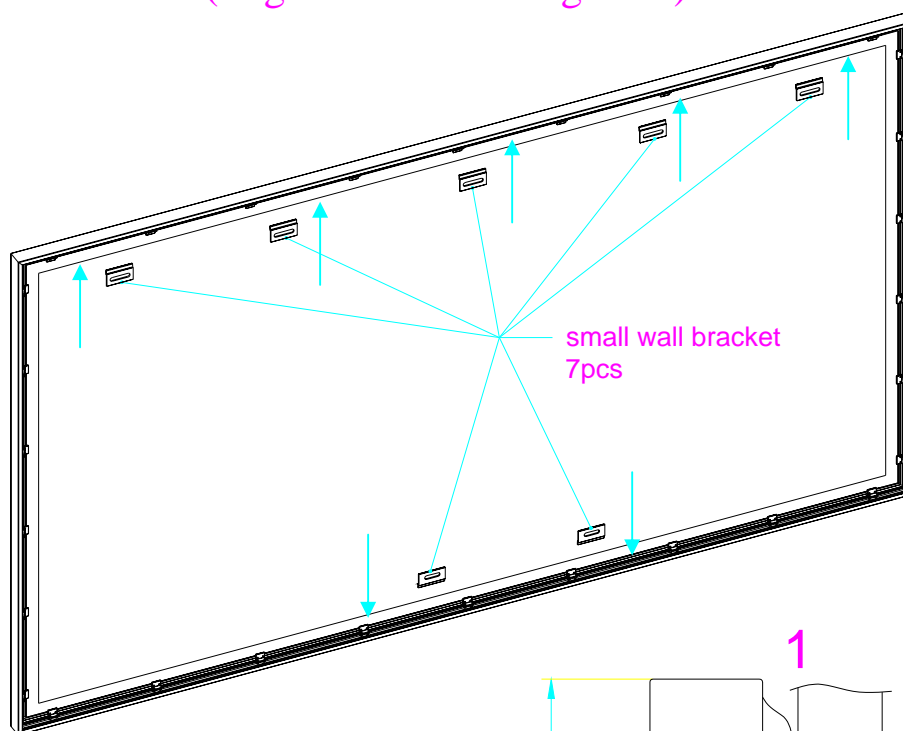

Position the screen with the attached surface onto the top wall bracket as shown in (fig.8). Push down at the center of the bottom frame rail to hook onto the lower wall bracket

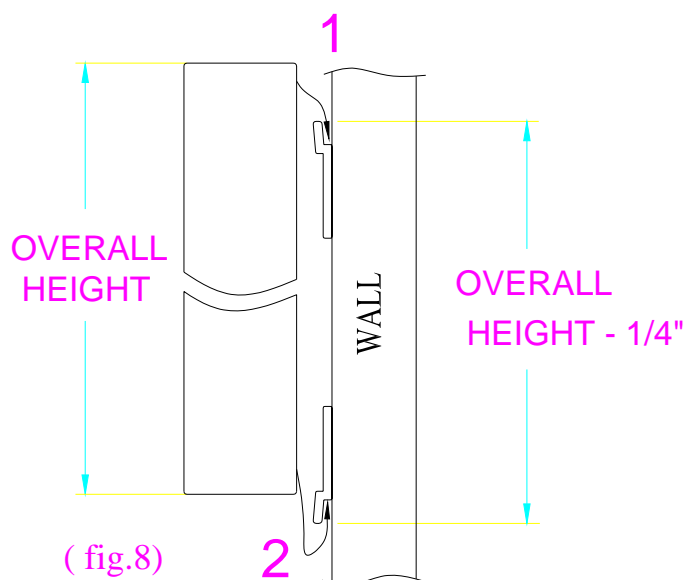

CAUTION

Please follow these instructions carefully to ensure proper maintenance and safety with your EZ-Frame Screen

1. When hanging the screen up, please make sure that no other objects such as power switches, outlets, furniture, ladders, windows, etc. occupy the space designated for your Fixed-Frame screen.
2. Regardless if the screen is hung on or installed into the wall, make sure that the proper mounting anchors are used and that the weight is supported appropriately by a strong and structurally sound surface just as any large and heavy picture frame should. (Please consult a home improvements specialist for the best advice on installation)
3. Frame parts are made of high quality velour-surfaced aluminum and should be handled with care.
4. When not in use, cover over the screen with a furniture sheet to protect it from dirt, grime, paint or any other impurities.
5. When cleaning, use a damp soft cloth with warm water to remove any marks on the frame or screen surface.
6. Never attempt to use any solutions, chemicals or abrasive cleaners on the screen surface.
7. In order to avoid damaging the screen, avoid touching it directly with your fingers, tools or any other sharp or abrasive objects.
8. Spare Parts should be placed out of reach for small children's in accordance with household safety guidelines.

Components List

1. Frame Part	4 pcs (2 long edges + 2 short edges)
2. Tension Rod	4 pcs (2 long rods + 2 short rods)
3. Screen	1 pcs
4. Joint	4 pcs
5. Fix Plate	30~60 pcs
6. Wall bracket	4~7 pcs
7. Screw	8 pcs
8. Manual	1 pcs

WARNING

The projection screen frame is made of high-quality aluminum alloy and should be handled with care.

Use a soft cloth with warm water to remove any spots on the screen surface.

To avoid damaging the screen material, never attempt to use any solutions, chemicals or abrasive cleaners on the screen itself and never attempt to touch screen with your fingers or sharps/abrasive objects.

Warranty Policy - Manual, Tripod, Floor Pull-up, and Fixed Frame Screens

**Valid in the United States of America. All international claims must go through their international distributor.*

- Two (2) year warranty on parts and labor from purchase date as follows (except for refurbished units as specified below):
- Refurbished units carry a 90-day parts and labor warranty.
- Demo units or open box items are “AS IS” items and do not carry a warranty.
- Each party will be responsible for one way shipping during the warranty return/exchange.
- DOA (Defective on Arrival): Must be reported within 7 business days of receipt. An RMA (Return Merchandise Authorization) number must be issued in order to process a replacement. Elite Screens will replace the DOA (Defective on Arrival) unit with a brand new replacement *(see exceptions below) after the DOA unit is received and/or confirmed defective. Once the product is received, Elite Screens will send out a new *unit to the customer by ground service (subject to inventory availability). Should a problem be reported after the 7-day grace period, the item must be shipped to us for warranty repair.
- Missing Parts must be reported within the 7-day (DOA) grace period. If reported after 7 days, customer will be only be responsible for shipping and handling fees up to 30 days. If reported after 30 days of receipt, customer is responsible for cost of the parts and shipping & handling fees.

Please visit the link below for full warranty information

<http://www.elitescreens.com/services.html>

REGISTER YOUR ELITE PRODUCT

TWO WAY TO REGISTER YOUR WARRANTY WITH ELITE SCREENS INC.

A. On Line (Faster and Easier) www.elitescreens.com/register.html

B. Fill out & Fax to (562) 483-8498, Attn: Customer Service Dept.

*Your Name: _____

Address: _____

City/State/Zip _____

*Email Address: _____

*Phone: _____

*Screen Model: _____

*Serial Number: _____

*Date of Purchase: _____

*Dealer / Reseller Purchased from (name of the reseller): _____

What is your Projector Model: _____

Application: Home Education Corporation Government
 Others

How would you rate this screen? Excellent Good Ok Improvement needed

Comments:

Contact info:

If you have pictures of your screen you'd like to share with us, please email your pictures to eliteinfo@elitescreens.com

or call us at 877-511-1211 EXT 203 or EXT 233

*Elite*SCREENS

www.elitescreens.com

For any technical inquiries,

techsupport@elitescreens.com