

# White Paper # 5201

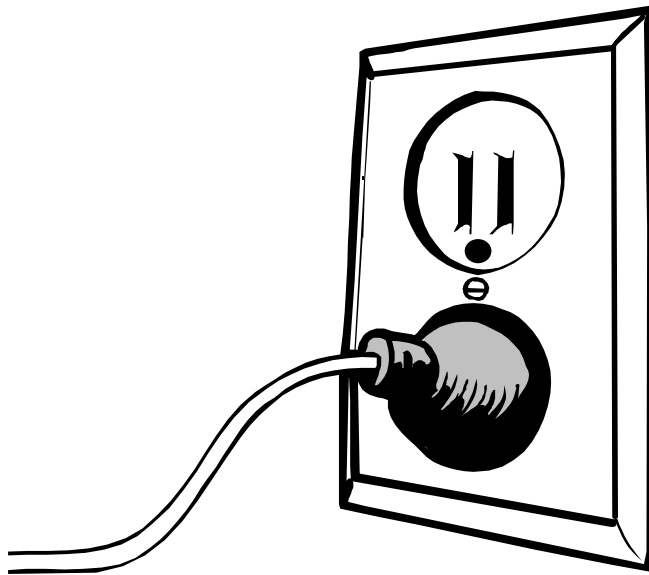

## Neutral to Ground Voltage Causes and Cures

White Papers are produced as an educational and informational tool by ETA Systems, 1450 Lakeside Drive, Waukegan, IL 60085. Comments are appreciated. Address your ideas, comments and replies to the above address. White Papers may be reproduced freely provided they remain complete and unchanged from their original form and content. Every effort is made to assure that the material presented in ETA SYSTEMS White Papers is complete, reliable, and technically accurate. For clarity and ease of presentation, however, some technical details may be simplified or omitted. Visit us on the web at [www.etasys.com](http://www.etasys.com). © 2005 - ETA Systems



**ETA SYSTEMS**

## Introduction

Neutral to ground voltage is a commonly discussed subject anytime power quality issues are the topic. What are neutral to ground voltages? Why do they occur? Why do they receive so much attention, and how can they be mitigated? These questions are all important in the operating environment of today's sophisticated electronic systems. Understanding neutral to ground voltages is a first step in assuring that modern technology operates reliably and economically.

## The Problem Defined

Common mode (CM) voltage is another term popularly applied to the neutral to ground phenomena. Neutral to ground voltage is any potential measured between the neutral (white) conductor and the safety ground (green or conduit) conductor of a building electrical system. This somewhat broad definition means that neutral to ground voltages can occur over a wide range of both frequencies and voltage amplitudes – a fact that is quickly substantiated after only a few observations.

The characteristics of neutral to ground voltage in any given environment are often unpredictable and as dynamic as the electrical environment itself. Neutral to ground voltages occur for several reasons. This discussion will examine three explanations.

## Shared Neutral Conductors

Electrical codes as well as accepted electrical practice permit the “sharing” of neutral conductors in a three-phase wye distribution. This practice allows one neutral conductor to serve three individual circuits as in Figure 1. Sharing of neutrals in a three-phase distribution is possible because of the

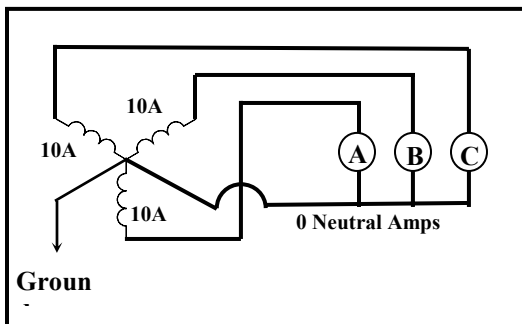

Figure 1 – Shared Neutral in 3 Phase Wye Distribution

unique vector relationship of the currents flowing in the three individual transformer phases.

In a wye distribution, each phase voltage is 120 degrees behind (lagging) the phase before it. Each phase current lags the preceding current by 120 degrees as well. If each phase carries an equal amount of current, a condition known as a “balanced

distribution”, the equivalent currents will all cancel each other out as they combine at the common neutral for return to the source. The result can be mathematically and algebraically shown to result in no (0 amps) of return current flow.

Based on this situation, one neutral instead of three will suffice for all three circuits. And since return currents are theoretically non-existent, most wiring codes permit the downsizing of the neutral conductor to a smaller gauge as well.

## Theory and Reality Collide

As is often the case, reality doesn't quite agree with theory. The previous example assumes the electrical system is powering loads that are linear in nature, that the system is resistive in nature, that the system is operating at unity power factor, and further, that the system operates in a state of complete equilibrium. In the real world, three phase systems are not as tidy. While electricians do their best to assure that currents in each leg are equal, it is not realistically possible to perfectly balance any three-phase system.

Elevators, compressors, and air handlers cycle in their operation. Computers, lights, copy machines, etc. are constantly being turned on and off. These changing conditions create imbalances in the system. The electrical environment is very dynamic and guaranteed to make a balanced three-phase system an electrician's “Holy Grail”.

As soon as currents become unbalanced in the example of Figure 1, phase currents no longer cancel and neutral current begins to flow. At this point, the laws of physics take over. As return current flows through the impedance of the neutral conductor, a voltage drop occurs. Since no return current occurs in the safety ground, a comparable voltage drop does not occur in safety ground. The result is a neutral to ground voltage differential.

## Load Balancing Difficulties

While changing load conditions make load balancing difficult, the proliferation of modern switch mode power supplies is an even larger factor. Switch mode power supplies consume current in non-linear “gulps” from the power line. In effect, they operate as though they are being rapidly turned on and off. In such installations, the electrician who perfectly balances all three RMS phase currents will find that current still flows in the neutral conductor. In some instances, instead of canceling, individual phase currents may even become additive.

Where there is current flow in the neutral, there will be neutral to ground voltage. This circumstance is to be expected in the modern facility even when good wiring practice and load balancing techniques have been observed.

## Branch Circuit Length

In the preceding example, neutral to ground voltage can be easily observed in a sub-panelboard. But many instances also occur in which neutral to ground voltage can be measured at the point of use – the electrical load.

When neutral to ground voltage is measured at a long branch receptacle, the cause is most likely not a shared neutral but the circuit length itself. The mathematical principals are the same. Consider the example of Figure 2.

This example shows a long branch receptacle at sufficient length from the source to cause a voltage drop of 4 volts AC. The voltage drop

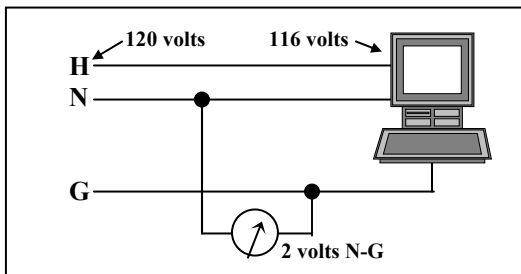

Figure 2 – Voltage Drop at Long Branch Receptacle

is a result of circuit impedance (inductive and capacitive reactance combined with conductor resistance). It's important to note that this voltage drop is due to the total circuit impedance of both the phase and the neutral.

Assuming that both the phase and the neutral are the same length and wire gauge, each conductor accounts for half the circuit impedance and, therefore, half of the observed voltage drop.

Since no return current flows in the safety-grounding conductor, it exhibits no comparable voltage drop. The result is a measured neutral to ground voltage differential of 2 volts AC.

Neutral to ground voltages at branch receptacles are directly proportional to circuit length and circuit current and inversely proportional to conductor size or cross-sectional area. In other words, making the circuit longer or increasing the circuit current will increase the neutral to ground voltage. Increasing the conductor gauge will reduce the neutral to ground voltage that occurs for any given length circuit at any given load. In fact, it is a common practice for electricians to increase the conductor size on longer or more heavily loaded circuits to reduce the observable voltage drop at the receptacle. When this is done, neutral to ground voltages are reduced as well.

## Induced/Conducted Voltages

The two previous examples explain neutral to ground voltages that occur at 60 Hz. Close

examination of numerous circuits with appropriate instrumentation will show that neutral to ground voltages also exist at higher frequencies. Often referred to as common mode “noise”, these disturbances have a different source altogether.

High frequency events may be continuous or sporadic, and they are either induced into the electrical conductor or they are conducted into it. The difference may be subtle but the results the same.

Induced disturbances couple into electrical conductors via electro-magnetic fields. Such disturbances can be the result of lightning, close physical proximity to motors or other devices with electrical windings, and the familiar static discharge associated with the dry air of winter.

Figure 3 illustrates what occurs when disturbances are induced into a current carrying conductor. Magnetic lines of force pass through the conductor resulting in disturbance current flow. Once

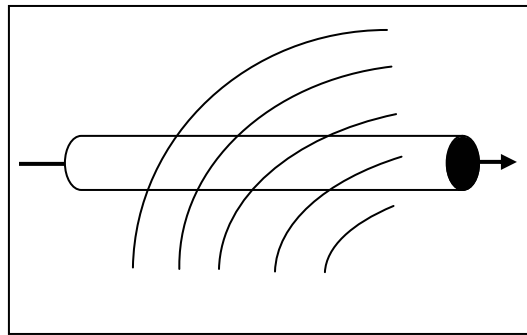

Figure 3 – Current Flow Resulting From Induced Voltage

again, the current flowing through the impedance of the conductor results in a measurable voltage drop.

Induced neutral to ground voltages are quite common since all conductors look like an antenna at some frequency. RFI and EMI from a variety of sources readily couple into not only the neutral and ground, but the phase conductor as well.

Conducted disturbances are virtually indistinguishable from the induced ones. The primary difference is in the disturbance source. Conducted disturbances are generated and inserted directly (conducted) into the electrical system by every device that uses electrical power. Conducted disturbances are the byproduct of the distribution and use of electricity.

It is an irony that many of the common mode voltage disturbances that affect systems are produced by the very systems themselves. Personal computers, copy machines, fax machines, laser printers, medical instrumentation, telephone switches, point of sale systems, audio and video systems, etc. all are significant contributors to the problem of conducted neutral to ground voltages.

Having defined neutral to ground events and the source, why are they of interest and how can their negative effects be eliminated?

## Disruptive Impact

Neutral to ground or common mode events can cause significant disruption to the operation of microprocessor based equipment. Modern logic circuits do not enjoy the electrical isolation that was part of the linear power supply that powered their predecessors. These circuits are constantly measuring logic voltages against the “zero voltage reference” of a clean safety ground. Since all of a computer’s decisions are the result of discriminating one rapidly changing low voltage signal from another, ultra-clean and quiet electrical safety grounds are essential. The microprocessor expects to see very low (less than .5 volts) of neutral to ground voltage.

Neutral to ground voltages can quickly destroy system productivity and have been observed to cause system lockups, communication errors, reduced operating throughput, unreliable data, fragmented hard drives, and operational problems that cannot be explained or duplicated.

## Finding Solutions

As mentioned earlier, neutral to ground voltages are the result of current flow through the impedance of wiring conductors. If either current flow or conductor impedance increases, the resulting voltage drop will increase, too. In addition, impedance is a characteristic that is determined by the frequency of the disturbance current. As the frequency increases, the impedance of the conductor also increases.

The implication here is plain. At some frequency, every conductor, regardless of how large, will exhibit undesirable impedance and a resultant voltage drop. This is particularly important in light of increasing microprocessor sophistication.

Common methods of reducing neutral to ground voltage include oversizing conductors in an attempt to lower impedance. Running individual neutrals instead of sharing them effectively accomplishes the same goal. But exercising total control over neutral to ground voltage means having effective control over the issue of impedance.

## Off the Shelf Technology

The most effective tool for control of neutral to ground and common mode disturbances remains the isolation transformer (Figure 4). Isolation transformers allow the bonding of neutral to ground on the transformer secondary. Disturbance current flow now occurs across the impedance of the bonding strap. Since this impedance is very low (almost zero), it is not possible to cause a voltage drop.

Full isolation of the load from the building electrical system is also provided by this technology. When used in conjunction with surge diverters and noise filters, isolation transformers eliminate the problems associated with these devices dumping

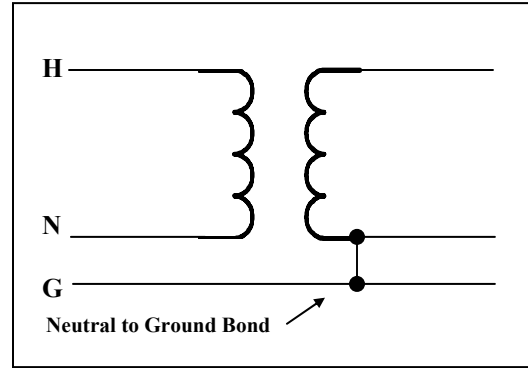

Figure 4 – Output Neutral to Ground Bond

disruptive disturbances to ground. For these reasons, ETA Systems includes an isolation transformer in every power quality solution intended for use with microprocessor based audio and video systems.