

**OWNER'S MANUAL  
OPERATION INSTRUCTIONS**

**January 2006**

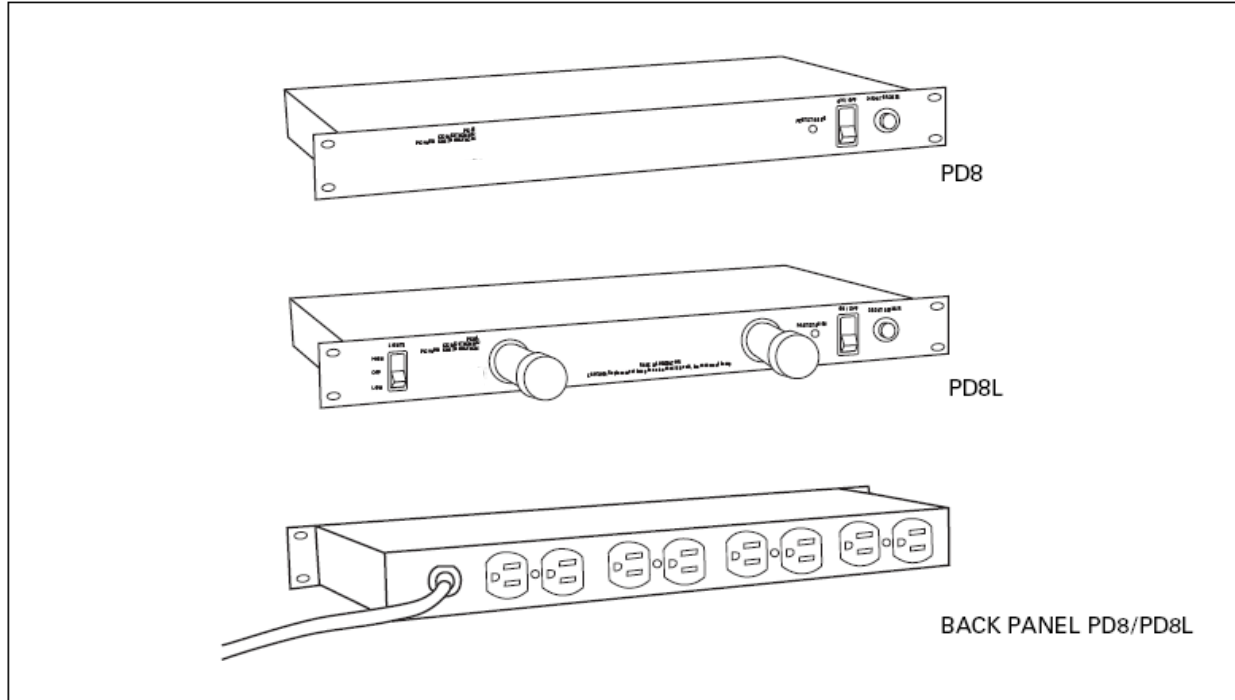

ETA's line of *Conditioned Power Distribution* units are designed to prevent electrical damage to sensitive electronic equipment from high amplitude/short duration spikes, random surges, and EMI/RFI noise, which is inherent in utility power lines.

Power line sources which are not preconditioned or filtered can affect reliable operation of sensitive audio, computer, and other electronic equipment, and may cause premature failure, expensive repairs, or unanticipated replacement from non-repairable damage.

As inherent problems in utility AC power lines increase for various reasons, and the need for noise-free, conditioned power increases, ETA is there with the units to protect your valuable electronic equipment. With present demands on the power utilities, voltage spikes, power surges, electrical noise, and power failures are

commonplace. This "garbage" in the power delivered can reduce the fidelity of audio systems, cause premature failure, or result in extensive damage or destruction of electronic equipment.

ETA Conditioned Power Distribution units feature a master power switch, conveniently located on the front control panel, that switches the rear panel AC outlets ON and OFF. An LED next to the master power switch indicates the power conditioning circuitry is working and the rear panel AC outlets are powered. Maximum total wattage input is 1800 watts and the 8 power output receptacles, located on back panel and one on front panel, are protected with a 15-amp (total unit) resettable circuit breaker.

Note: The front panel LED is normally lit when the power switch is in the ON position. If the power switch is ON and the LED is

*not* lit, power may still be present on the output AC receptacles, but the power conditioning circuitry is not working. Do not continue use of the power conditioning unit and refer trouble-shooting to a qualified electronic technician or contact ETA Customer Service for assistance.

**EASY INSTALLATION**

The PD8 and PD8L is easily mounted into a standard 19-inch rack or placed into a free-standing position. With the PD master power switch in the OFF position, plug the line cord into a convenient AC receptacle. Place the PD8 power switch into the ON position and check that the front panel LED is lit. The lit LED indicates conditioned and filtered AC power is connected. Then, with their master power switches in the OFF position, plug the equipment to be protected into the PD's rear panel AC receptacles. Turn on the power switches of the equipment plugged into the PD8.

## MODELS PD8 / PD8L : CONDITIONED POWER DISTRIBUTION

### SPECIFICATIONS:

Dimensions	19" L x 8" D x 1 3/4" H
Weight	7 lbs. (less packaging)
Housing Quality	Black powder coated chassis
Electrical	120V, 50/60 Hz, single phase
Max. amps	15/ unit
Max. watts	1800/ unit
Spike/surge protection	Line to neutral, neutral to ground, Line to ground
Surge protection alarm	yes
Response time	< 1 nanosecond
Max. clamping voltage	330V
Max. spike current	65,000 amps
Max. surge energy	1665 joules total (555 per leg)
Noise filter (EMI/RFI)	Frequency 150 kHz -100 MHz Attenuation up to 68 dB
Certification	UL 1449 Listed

### PD8 AND PD8L FEATURES

- 15 amp input – breaker protected
- 8 AC outlets
- Surge protection alarm
- Spike, surge and EMI/RFI filtered
- Watchdog protected circuitry with  
"Go/ No Go" L.E.D. display
- Rack illuminators
- 1 rack space
- 3 year limited warranty

### EASY 4-STEP BULB REPLACEMENT 120 volt 4 watt bulb (Christmas tree bulb)

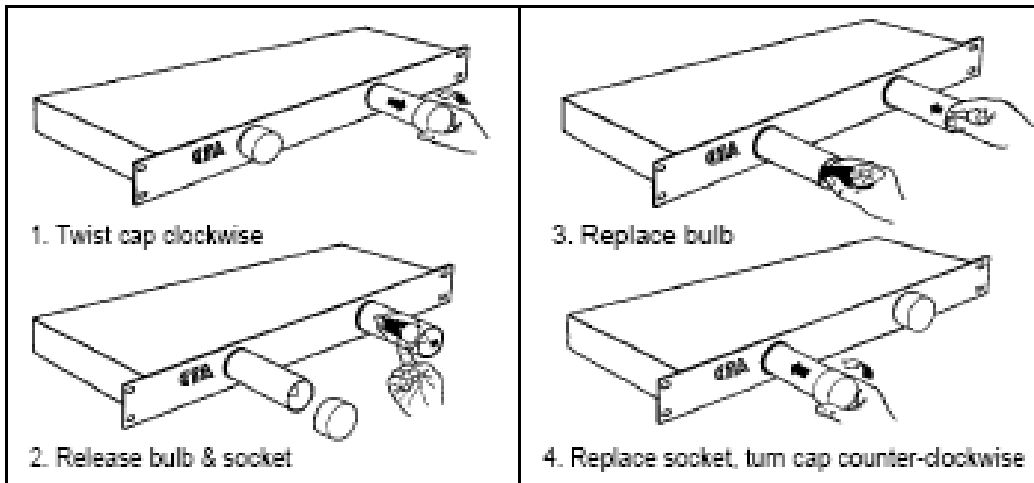

## When You're Ready to Move Up, Check Out The Complete ETA Pro Series At Your ETA Dealer

Select from UL and ETL Listed Conditioned Power Distribution Units, AC Line Voltage Regulators/Stabilizers, Sequential Power Turn-on Units and Rack Mounted High Amperage Output Distribution Boxes.

CE Compliant Models also available from authorized International Distributors

