

OWNER'S MANUAL

AC POWER REGULATOR SEQUENTIAL POWER UP / POWER DOWN



PD10VRS



PD10VRS-IQ

- Section 1 - Introduction
- Section 2 - Quick Set-Up / Check
- Section 3 - Set-Up and Operation
- Section 4 - Why Line Conditioning?
- Section 5 - IQ System Assembly & Test Procedures
- Section 6 - 230 Volt/50 Hertz Version



1450 Lakeside Drive • Waukegan, Illinois 60085 USA
330-677-4424 • 800-321-6699 • Fax: 330-677-4471
<http://www.etasys.com> E-mail eta@etasys.com

All designs and specifications are subject to change without notice. Copyright © 2006 ETA Systems. 6MAN-027

Section 1: Introduction

Thank you for purchasing an ETA Conditioned Power Distribution AC Line Regulator. We are confident that you will find this instrument to be reliable and invaluable in protecting electronic equipment. Please contact us at 1-800-321-6699 with any operation or installation questions.

Your Model PD10VRS (four-stage sequencing model) has a microcomputer to manage all operational controls and digital display functions. The result is a sophisticated system that monitors all conditions and computes performance for every power cycle. Once that information is analyzed, the microcomputer activates the required changes. The microcomputer can terminate output power within a power cycle; however, it uses more intelligent strategies to prevent unnecessary changes or shutdown due to momentary transients (e.g. transient caused by rapid switching power supplies).

The capabilities outlined below are but a brief listing. For in-depth information, proceed to Section 3.

Unique features are as follows: provides full 15 amp output; regulates within an incoming voltage range of 80 to 150 volts; maintains AC voltage within 3 volts at nominal 117 VAC (nominal 100 VAC in Japan); and always regulates to within a 107 to 125 volt range. Please note that most electrical equipment is designed to operate within the 107-125 volt range. Therefore, when incoming voltage is below 80 or above 150 volts, the regulation is terminated.

Another unique ETA feature is "Auto Restart" following a complete power outage. Automatic Restart will only restart when incoming power demonstrates a continued and confirmed flow of sustained power.

Digital Voltmeter/Message Display Interface

When the unit is initially energized or plugged into a standard 20 amp service, the display reads the non-regulated voltage. When the power switch is activated to the "ON" position, the readout displays regulated voltage. When the input voltage drops below 90 or exceeds 138 volts, the display flashes the regulated voltage indicating the unit is still regulating but voltage may be approaching a cut off level. The digital display reads "LO" or "HI" when incoming voltage drops below 80 or exceeds 150 volts and shutdown has occurred. "LO" or "HI" will flash when unregulated voltage is below 80 or above 150 volts upon initial energized or re-activated after shutdown has occurred.

Display Modes:

1. AC input line voltage
2. Flashing "HI" or "LO"
3. AC regulated output voltage
4. Flashing regulated voltage
5. Steady "HI" or "LO" if output shut down from fault condition

15 amp fast-acting fuse protects black regulated outlets

20 amp circuit breaker protects toroidal power regulation transformer and ivory outlets

Fig. 1

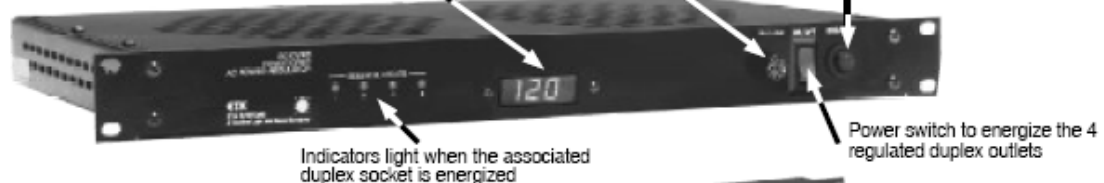
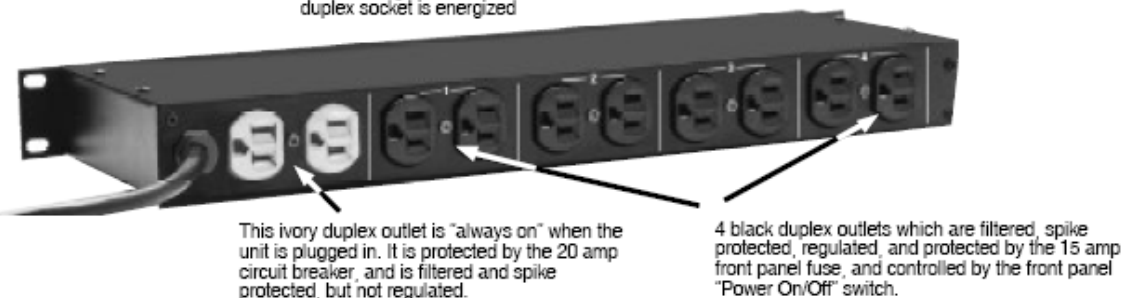

Fig. 2



Additional Features of PD10VRS:

- Spike, Surge and RFI/EMI suppression and filtering
- Zero-crossing triac switching
- Always 15 amp output in a single rack space
- High efficiency 20 amp toroidal autotransformer
- 10 conditioned and protected power outlets
- 2 "Always-On" and protected outlets
- 8 regulated power outlets
- Input and output circuit protection located on the front panel for convenient access
- L.E.D. status indicator located on the front panel

- Quick field diagnostic test procedures with visual check and test points for operational status and easy component replacement
- Automatic Restart
- True RMS conversion circuit

Filed Adjustable Features:

- Calibration for both incoming non-regulated and regulated volts (only to be used in extreme situations) see Fig. 4A. Factory calibrated to 117 volts nominal
- Time intervals from 1.5 to 34 seconds
- Density of message display from bright to off

Fig. 2A
Remote hook-up

Hook-up is made directly on the PC board on the inside of the unit. Remote wires are brought outside the unit through the vent holes in the side sheet metal.

NOTE: Remote latching switch is always subject to the master power switch on the unit. The master switch must be in the "Off" position for the remote switch to operate.

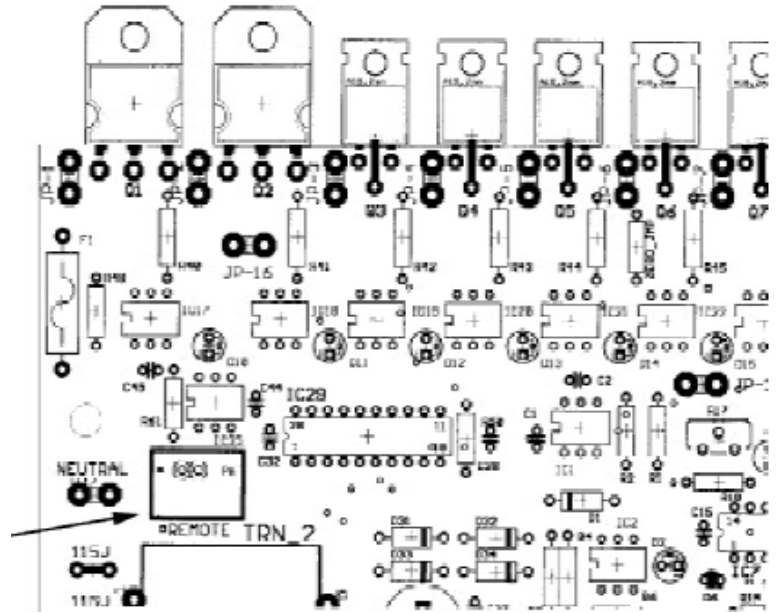
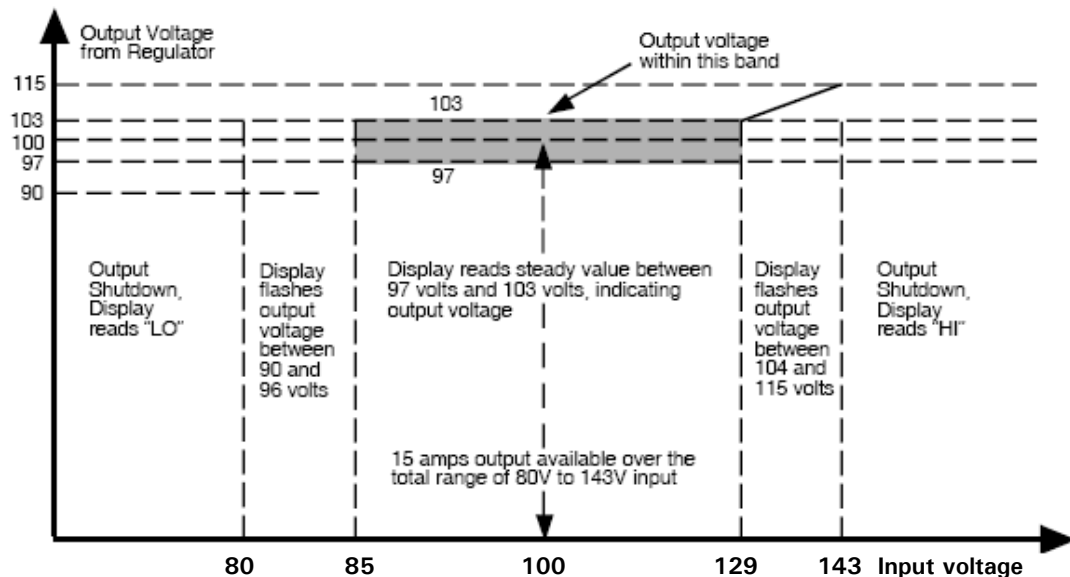
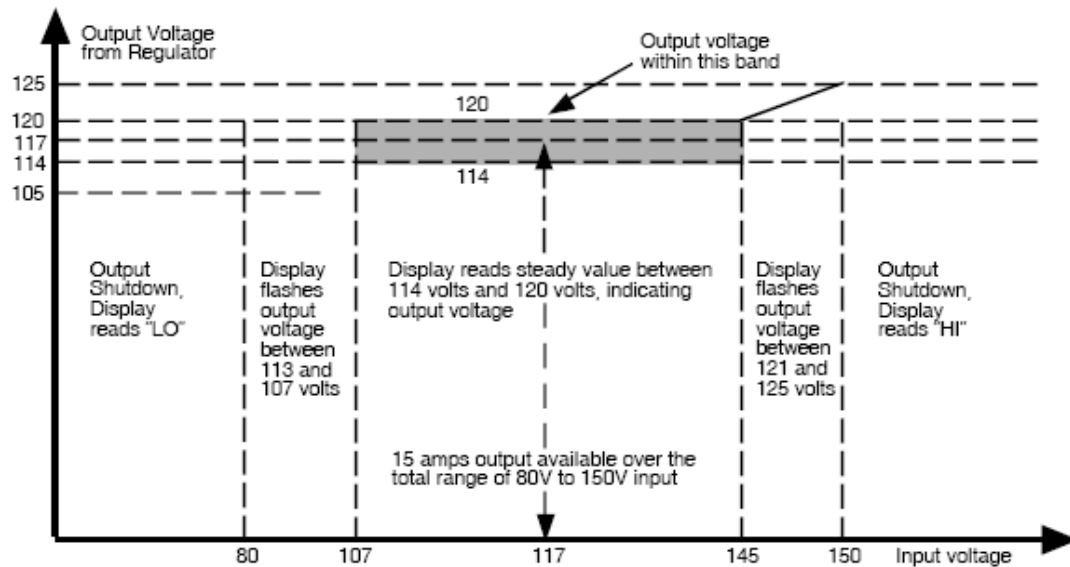

Fig. 3B



Section 2: Quick Setup & Quick Check

- 1). Plug the voltage regulator into a 20 amp power source. A 12/3 UL rated extension cord should be used if needed. (A 15 amp power source may be used, but not recommended to provide a full 15 amp output).
- 2). Verify the incoming voltage is between 80 and 150 volts to begin regulation.
- 3). Plug equipment to be regulated into the black outlets. Equipment that requires "always on" power, filtration and circuit breaker protection should be plugged into the ivory outlets.
- 3). To begin regulation or reactivate regulation, move the power switch to the "ON" position. (May require moving power switch to the "OFF" position then back to "ON" for reactivation.)
- 4). It is not unusual to experience a soft pulsation emitting from the toroidal transformer with the initial in-rush of power. It is normal mechanical interference which is temporary, and will not interfere with output regulation or create line noise.
- 5). Digital voltmeter display indicates several different operating levels.
 - A. Incoming AC line voltage when power switch is in the "OFF" position or when regulation has been terminated.
 - B. Flashing "HI" or "LO" display occurs when the power switch is in the "OFF" position (or regulation has been terminated) and the unregulated incoming AC power has fallen below 80 volts or has exceeded 150 volts.
 - C. Displays the regulated AC output voltage (the voltage your equipment is seeing). When incoming AC voltage is between 90 and 138 volts.
 - D. Display flashes a regulated AC output voltage when incoming voltage is between 80 and 89 volts or between 139 and 150 volts. The flashing display indicates the incoming voltage may be approaching the cut off voltage but at this point is still in usable range.
 - E. A steady "HI" or "LO" message indicates that during regulation the incoming AC line voltage fell below 80 volts or exceeded 150 volts. Regulation is terminated, and shut down has occurred.
 - F. Automatic restart reestablished AC power and normal operation following high or low voltage shut down.
 - G. A dark voltmeter display indicates the 20 amp circuit breaker has been tripped disconnecting power from the regulator; typically because the input current demand exceeded 20 amps. Another reason for a dark display is the digital display intensity may have been adjusted too low.
 - H. No output to the regulated outlets and a displayed voltage indicates that the fuse has been tripped; typically because of a fault in the equipment being regulated.

Reference incoming voltage with display readout when nominal AC voltage is 117 volts		When Nominal AC Voltage is 100 Volts	
Incoming Voltage	Voltmeter Displays	Incoming Voltage	Voltmeter Displays
90 - 138 volts	117V + 3V	86-127 volts	100V + 3V
80-89 volts	107-113	80-85 volts	90-96
139-150 volts	121-125	128-143 volts	104-115
Below 80 volts	"LO"	Below 80 volts	"LO"
Above 150 volts	"HI"	Above 143 volts	"HI"
Voltmeter displays incoming voltage until power is initiated		Voltmeter displays incoming voltage until power is initiated	

Section 3: Set-up And Operation

(Refer to figures 1-3)

The PD10VRS requires one rack space when mounted in a standard rack. Since the units are heavy, be sure the strength of the mounting rails on the rack are sufficiently strong to support the power regulator, especially if the rack is to be transported with equipment installed. Room for air to circulate around your equipment is necessary to carry off the heat created by all the equipment mounted in the rack.

Model PD10VRS has 8 black, filtered, protected and regulated outlets which turn on and off sequentially. Plug the equipment which needs protection and regulation into any of the 8 black outlets. The 2 ivory outlets provide continuous power, filtration and circuit breaker protection, no regulation is provided. Any outlet or combination of outlets can support up to 15 amps of load current demand.

When the regulator is connected to an AC power source, the digital voltmeter display will initially indicate the unregulated incoming AC line voltage regardless of the position of the power switch. This feature is to insure that the operator has initiated the power up of equipment which needs to be regulated. Therefore, if the power switch is in the "OFF" position when the unit is plugged in, or after there is an unexpected power outage, the operator need only place the power switch in the "ON" position. If the power switch is already in the "ON" position when the unit is plugged in or a power outage occurs, regulation will begin only when the operator resets the regulator by moving the power switch to the "OFF" position and then back to "ON".

The digital voltmeter display will indicate unregulated AC input voltage when the power switch is in the "OFF" position, unless the input voltage falls below 80 volts RMS or rises above 150 volts RMS. At below 80 volts, the display will flash a "LO" message, and above 150 volts the display will flash a "HI" message, indicating the line voltage is beyond the functional range of the equipment.

When the power switch is placed in the "ON" position, the digital voltmeter display indicates the regulated AC voltage supplied to the 8 black outlets. The digital voltmeter display will read between 114 volts and 121 volts when the incoming AC voltage is approximately 90 volts to 138 volts. The displayed value under this closely regulated condition by the microcomputer, will remain on and be updated as the output voltage varies within the bounds of 114 volts and 121 volts regardless of the variation in the input voltage.

If the incoming AC voltage goes below 90 volts, or above 138 volts, the output voltage will continue to be regulated and the voltmeter display will vary below 114 volts or above 121 volts. Since the cut-off point for the voltage supplied to your equipment has been set to 107 volts and 125 volts at the regulated outlets, the displayed output voltage will read flashing between 107 and 113 volts or between 122 and 125 volts.

The flashing display indicates the unit is outside of the tight-regulation band and approaching the cut-off voltage. If the unregulated line voltage returns to a value between 114 and 121 volts, the flashing will automatically stop.

If the unregulated incoming voltage deviates further to below 80 volts or above 150 volts, causing the regulated output to fall below 107 or rise above 125 volts, the black regulated outlets will immediately shut down and the voltmeter display will read a steady message "LO" or "HI". The voltmeter display will hold this condition until the power switch is turned off, at which time the voltmeter display will again read the unregulated AC incoming voltage or a flashing "LO" or "HI".

Fig. 3

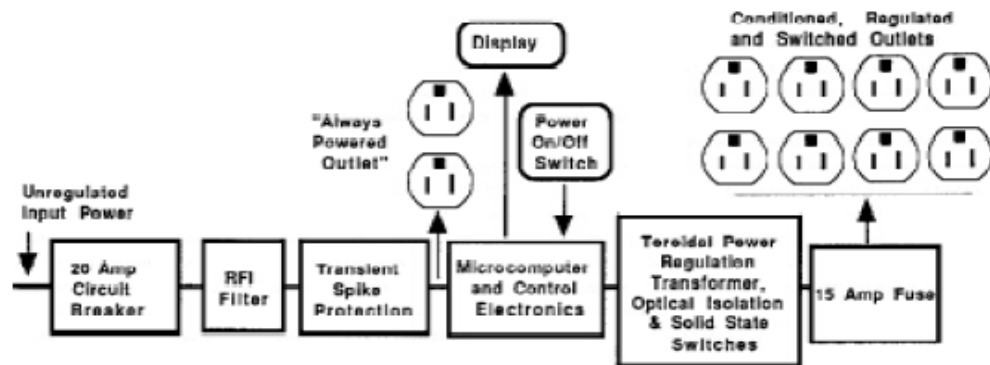

Input Voltage volts	Input Current (max)	Output Voltage volts	Output Current amps
80	15.0	117	9.6
90	15.0	117	10.8
100	15.0	117	12.0
110	15.0	117	13.2
117	15.0	117	14.0
120	15.0	117	14.4
130	15.0	117	15.0
140	15.0	117	15.0
150	15.0	117	15.0
<hr/>			
80	20.0	117	12.8
90	20.0	117	15.0
100	20.0	117	15.0
110	20.0	117	15.0
117	20.0	117	15.0
120	20.0	117	15.0
130	20.0	117	15.0
140	20.0	117	15.0
150	20.0	117	15.0

The first section of Table 1 assumes the regulator is connected to a 15 amp circuit and the second section assumes the unit is connected to a 20 amp circuit. Each section shows the maximum load current for a range of input voltages without causing the input circuit to exceed it's maximum current.

Example 1

When connected to a 15 amp breaker, the output capability drops off for input voltages below 130 volts, and a maximum of 12 amps can be delivered to the regulated output (117 volts) where the input voltage is only 100 volts. This is not a restriction due to the ETA voltage regulator, but is due to the rating of the input circuit from the wall outlet.

Example 2

When connected to a 20 amp breaker, the regulated output can deliver a full 15 amps for input voltages down to 100 volts and can deliver 14.4 amps all the way down to 90 volts.

Time Sequencing the PD10VRS

Model PD10VRS has a time-sequencing controller built into its microcomputer. This allows the regulator to activate power and regulation in a time delayed fashion to the 4 black duplex outlets. The total current from all 4 circuits must not exceed the 15 amp limit, but the individual currents can be any value up to 15 amps. The regulator will apply regulated power to multiple pieces of equipment in a specified time sequence (i.e. first turn-on device "A", the device "B", then "C" and so forth.) When this arrangement is de-energized, it is desirable to power down the devices in the reverse order from that in which they were powered up (i.e. power down "C", then "B", etc.).

The brightness of the digital voltmeter display may be adjusted along with the time delay between each circuit being activated. Adjustments within the regulator are necessary. CAUTION! ADJUSTMENTS SHOULD ONLY BE MADE BY QUALIFIED SERVICE PERSONNEL. HIGH VOLTAGES APPEAR AT MANY POINTS ON THE CIRCUIT BOARD AND MANY OTHER POINTS ON THE CHASSIS. SINCE THE COVER IS REMOVED TO MAKE THESE ADJUSTMENTS, IT IS POSSIBLE TO BE INJURED BY TOUCHING ANY OF THESE HIGH VOLTAGE POINTS.

To adjust the brightness of the digital voltmeter display unplug the regulator from the power source, remove cover and visually locate the potentiometer identified as "Voltmeter Display Adjustment (See Figure 4.) Rotate the potentiometer counterclockwise to increase display brightness, and clockwise to decrease display brightness.

To adjust the sequencing delay time, unplug the regulator from the power source, remove the cover and visually locate the potentiometer identified as the "Sequence Delay Potentiometer" (See Figure 5.) Rotate the potentiometer counterclockwise to increase the time delay to up to 35 seconds between each circuit re-

Fig. 4

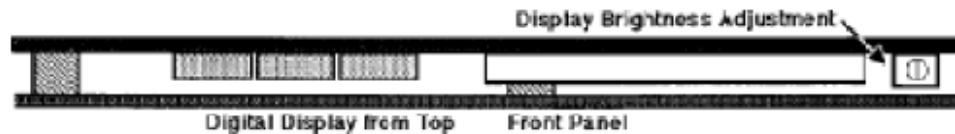

Fig. 4A

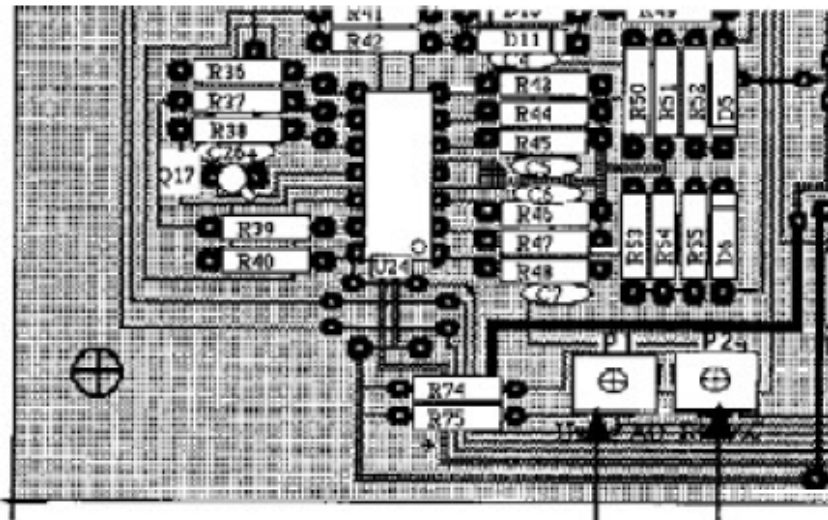
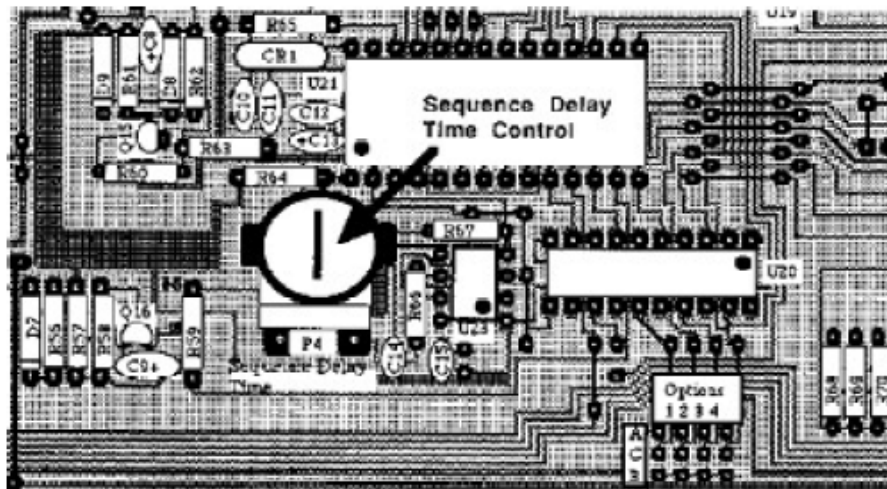

Fig. 5



Section 4: Basics of Line Regulation and Conditioning

The power delivered by the local utility company appears at the AC outlets at a standardized voltage, with an operating tolerance. In the USA this voltage is nominal 117 volts and may vary from 107 to 125 volts. (Japan's nominal is 100 volts.) Because power is not guaranteed to be stable and clean, the line voltage may be lower than 105 or higher than 125 volts, and may also have EMI (electromagnetic interference) or RFI (radio frequency interference) mixed in with the 60 Hz 117 volts power signal. ETA's AC Line Regulator Model PD10VRS is designed to resolve line voltage irregularities by providing clean, stabilized power to sensitive electrical equipment.

The unregulated voltage may also have very large "transient" voltages that are narrow in width (pulses of several hundred to several thousand volts that last millionths or thousandths of a second) due to motors turning on or off, effects from a storm, or from numerous other sources. These transients are absorbed by transient suppressors in the power conditioning equipment before they can enter your equipment and damage components by "over-voltage breakdown".

Finally, the voltage can be regulated so that the variations in line voltage is minimized, before it is supplied to your equipment. This reduces the possibility of overheating, reduces or eliminates motor speed variation in tape decks and other devices, and maintains the specified output power of amplifiers, even under low voltage conditions.

Figure 3 illustrates how the AC power from the power source is monitored and processed as it flows through before appearing at the conditioned, regulated black outlets provided for your equipment.

Section 5: Assembly & Test Procedure

PD10VRS & Crown IQ Interface

Models: PD10VRS, PD16VRS

1. EQUIPMENT NEEDED

- PD10VRS or PD16VRS
- Crown IQ Interface Kit
- IBM compatible computer, with Windows 95 or NT
- Crown IQ software package
- Varactor (Operation Test only)
- Common Tools

2. ADVISORY INFORMATION

• High Voltages are present inside of the PD10VRS units when operating. PREFORM IQ MODIFICATION ON UNPOWERED UNIT ONLY.

3. ASSEMBLY

- Open the Crown IQ Interface kit, inspect the kit for the following items:
 - a) Crown IQ expansion interface, with cable assemblies attached
 - b) 1 each PD10VRS microprocessor, VRA-xxx, xxx = 100,117,230
 - c) 1 floppy disk, ETA /Crown IQ files
 - d) 8 each of #8 x 3/8 sheet metal screws
- Remove the four sheet metal screws holding the lid on the PD10VRS unit.
- Remove the lid from the PD10VRS unit and set it aside for later use.
- Carefully replace IC13 of the PD10VRS unit with the VRA-xxx microprocessor supplied. It is located near the front left hand corner of the printed circuit board.
- Locate the autostart jumper next to IC11 marked "D" and inside of a white box outline. Carefully clip this jumper out.
- Position the Crown IQ interface over the PD10VRS unit, be careful not to pinch any of the cable assemblies between the two pieces.
- Plug in the following cable assemblies, note the cable connectors are keyed and designed to go on one way only.

Number of wires	From the Crown IQ	To the PD10VRS
10	JP6	P3
5	JP7	P1

- Pull the white wire marked neutral from the printed circuit board in the PD10VRS unit. Plug the white wire double quick disconnect from J1 on the Crown IQ interface on to the terminal marked neutral. Finally plug the white wire that was plugged on to the neutral terminal back on to the double quick disconnect.
- Pull the black wire marked JP-16 from the printed circuit board in the PD10VRS unit. Plug the black wire double quick disconnect from J1 on the Crown IQ interface on to the terminal marked JP-16. Finally plug the black wire that was plugged on to the JP-16 terminal back on to the double quick disconnect.
- Align the Crown IQ interface over the PD10VRS unit so that the eight mounting holes are aligned properly.
- Using the supplied #8 x 3/8 sheet metal screws attach the Crown IQ interface to the PD10VRS unit.
- Attach the lid removed from the PD10VRS unit on to the top of the Crown IQ interface with the four sheet

4. SYSTEM SETUP

- Connect the input and output loop of the Crown IQ/PD10VRS unit to the serial loop of the Crown IQ interface. This means the output from the Crown IQ serial interface goes to the input of the Crown IQ/PD10VRS unit. The input from the Crown IQ serial interface goes to the output of Crown IQ/PD10VRS unit. Ensure to observe polarity during this hookup.
- If you have not installed the Crown IQ software package on your computer do so now following the installation instructions supplied by Crown. Then copy the files from the ETA Software disk into the same subdirectory that was created for the Crown IQ software.
- Plug the serial port connector from the Crown IQ serial interface into the serial port of your computer.
- If you are running multiple pieces of equipment on the Crown IQ system you should set the address switches on the back of the Crown IQ/PD10VRS unit to an address that does not conflict with addresses already in use, otherwise you can just set the address to 1.

Switches	1	2	4	8	16	32	64	128
Addr 1	OFF	ON	ON	ON	ON	ON	ON	ON
Addr 3	OFF	OFF	ON	ON	ON	ON	ON	ON

5. SOFTWARE OPERATION

- Apply power to the Crown IQ PD10VRS unit and the Crown IQ interface.
- Double click on the Crown IQ icon on your desktop screen.
- Wait for roll call to be completed, your Crown IQ serial interface and the Crown IQ/PD10VRS should each then have an icon on the following screen.
- Move your mouse pointer over each of the icons, and double click on the ETA Systems PD10VRS icon.
- Use the pointer and mouse to click on the † arrow box of the CONTROL PANEL, then grasp the solid bar at the top of the PD10VRS control panel and move the panel to the center of the screen.
- The nine L.E.D. indicators at the top marked "LINE INPUT TAP" show which tap is currently being used when the PD10VRS is on. The "VOLTS AC" indicator shows either the unregulated voltage when the unit is off, or the regulated voltage when the unit is on. The four sequence L.E.D. indicators show as each output turns on in order. The Over Voltage and Under Voltage L.E.D. indicators show when the PD10VRS unit goes out of limit either high or low and switches off.
- The Autostart button, enables or disables the autostart function. When enabled, the PD10VRS unit goes either out of limit high or low and switches off, and then when the line voltage comes within limits the PD10VRS unit will switch back on.
- The Regulator Enable button turns on or off the PD10VRS unit.
- The Sequence Mode button enables or disables the sequence mode of operation. (ON 1,2,3,4, OFF 4,3,2,1)

6. OPERATIONAL TEST

- Turn OFF computer and PD10VRS, plug the PD10VRS into the Varactor. Adjust the output of the varactor for a nominal line voltage. Turn on the computer and bring up the Crown IQ software as outlined in section 5.
- Click on each of the control buttons AUTOSTART, REGULATOR, and SEQUENCE ensuring that each button is in the OFF position.
- Click on the REGULATOR button, the VOLTS AC indicator should show the regulated voltage and the Heading "REGULATED".

- The LINE INPUT TAP indicators should have one L.E.D. indicator lit indicating which tap is in use. Adjusting the varactor slowly should cause the LINE INPUT taps to change position. Do not adjust the varactor past the point of either the lowest or highest tap or the PD10VRS unit will shut off.
- All of the four SEQUENCE L.E.D. indicators should be lighted.
- Click on the SEQUENCE button, and then click the REGULATOR button off.
- The SEQUENCE L.E.D. indicators should sequence off in order 4,3,2, and then 1. The VOLTS AC indicator should show the unregulated voltage and the heading "UNREGULATED".
- Click the AUTOSTART and then the REGULATOR buttons on, the four SEQUENCE L.E.D. indicators should sequence on 1,2,3,4 and the REGULATED voltage should be displayed.
- At this point change the varactor until the AC line voltage goes LOW out of limit, the PD10VRS should shut off, and the UNDER voltage L.E.D. corresponding indicator should be lit. The PD10VRS cannot turn back on from this point, until the AC input line voltage comes back into limits, turn the varactor up until the unit comes back on.
- At this point change the varactor until the AC line voltage goes HIGH out of limit, the PD10VRS should shut off, and the OVER voltage L.E.D. corresponding indicator should be lit. The PD10VRS cannot turn back on from this point, until the AC input line voltage comes back into limits, turn the varactor down until the unit comes back on.
- Click on the AUTOSTART button turning it OFF, taking the AC input voltage high or low by using the varactor will cause the PD10VRS unit to shut off and indicate either OVERVOLTAGE or UNDERVOLTAGE. The PD10VRS units will not switch back on when you bring the AC input line voltage back into limits. You must toggle the REGULATOR button OFF and then ON to turn the PD10VRS unit back on with AUTOSTART off.

NOTES: ETA Systems provides the working files .dig, dll, and .oif for use with PD10VRS and Crown IQ interface. This software provides the CONTROL PANEL for the PD10VRS system with Crown IQ interface, under the Crown Windows operating system.

Crown provides the Crown IQ Windows operating system. Crown is responsible for installation and support relating to the Crown Windows operating system. ETA Systems provides support for questions and problems relating to the PD10VRS control panel, and PD10VRS unit.

Section 6: Model PD10VRS 230 Volt Version

Additional Features:

- Spike, Surge and RFI/EMI suppression and filtering
- Zero-crossing triac switching
- Always 8 amp output in a single rack space
- High efficiency 10 amp toroidal autotransformer
- 10 conditioned and protected power outlets
- 2 "Always-On" and protected outlets
- 8 regulated power outlets
- Input and output circuit protection located on the front panel for convenient access
- L.E.D. status indicator located on the front panel
- Quick field diagnostic test procedures with visual check and test points for operational status and easy component replacement
- Automatic restart
- True RMS conversion circuit

Filed Adjustable Features:

- Calibration for both incoming non-regulated and regulated volts (only to be used in extreme situations) — Factory calibrated to 230 volts nominal (see Fig. 4A)
- Time intervals from 1.5 to 34 seconds
- Density of message display from off to full bright

If the incoming AC voltage goes below 213 volts, or above 276 volts, the output voltage will continue to be regulated and the digital display will flash a varied value between 213 to 226 volts on the “LO” side and between 241 to 259 volts on the “HI” side. The flashing display indicates that the unit is outside of the tight regulation band and approaching the cut-off voltage. If the unregulated incoming line voltage returns to a value between 213 and 276 volts, the flashing will automatically stop.

If the unregulated incoming line voltage deviates further to below 180 volts or 296 volts, causing the regulated output to fall below 213 volts or rise above 259 volts, the 8 black outlets will immediately shut down. At this time the voltmeter display will read a steady message “LO” or “HI”. The voltmeter display will hold this condition until the power switch is turned off, at which time the voltmeter display will again read the actual unregulated incoming AC line voltage or a flashing “LO” or “HI”.

The 10 amp front panel circuit breaker may trip, disconnecting power from the regulator if the input current demand is greater than 10 amps. The voltmeter display will go dark at this time.

The 8 amp fuse may trip, shutting down power to the black outlets if a fault occurs with the equipment plugged into the regulator. Under this condition, the voltmeter display will still indicate the regulated AC output voltage, even though the voltage is not available at the black outlets. Figure 3 shows the flow of power through the regulator and the location of the control and protection components in that path.

Time Sequencing the PD10VRS (220-230 Volt Version)

Model PD10VRS has a time-sequencing controller built into its microcomputer. This allows the regulator to activate power and regulation in a time delayed fashion to the 4 black duplex outlets. The total current from all 4 circuits must not exceed the 8 amp limit, but the individual currents can be any value up to 8 amps. The regulator will apply stabilized power to the 4 circuits represented by the 4 black duplex outlets in an ordered sequence: one, then two, three, and finally four. The power down order is first circuit four, the three, two, and finally circuit one. The PD10VRS is factory set at approximately a 5 second sequencing time delay between circuits.

Field Adjustments of PD10VRS (220-230 Volt Version)

The time delay between circuits on the PD10VRS may be field adjusted as well as the brightness of the digital voltmeter. These adjustments need to be made under the cover or inside the regulator. **CAUTION! ADJUSTMENTS SHOULD ONLY BE MADE BY QUALIFIED SERVICE PERSONNEL. HIGH VOLTAGES APPEAR AT MANY POINTS ON THE CIRCUIT BOARD AND MANY OTHER POINTS ON THE CHASSIS. SINCE THE COVER IS REMOVED TO MAKE THESE ADJUSTMENTS, IT IS POSSIBLE TO BE INJURED BY TOUCHING ANY OF THESE HIGH VOLTAGE POINTS.**

Sequence Time-Delay Adjustment

Sequence delay time may be field adjusted, with option of 1.5 seconds to up to 35 seconds, using the following procedure. Unplug the regulator from the power source, remove the cover and visually locate the potentiometer identified as the “Sequence Delay Potentiometer”. (See Figure 5.) Rotate the potentiometer counterclockwise to increase the time delay to up to 35 seconds between each circuit, and clockwise to decrease the time delay to as few as 1.5 seconds between each circuit.

Digital Voltmeter Display Brightness Adjustment

The brightness of the digital voltmeter display may be adjusted using the following procedure. Unplug the regulator from the power source, remove the cover and visually locate the potentiometer identified as “Voltmeter Display Adjustment. (See Figure 4.) Rotate the potentiometer counterclockwise to increase display brightness, and clockwise to decrease display brightness.

Model PD10VRS 230 Volt/50 Hertz Version

Fig. 3

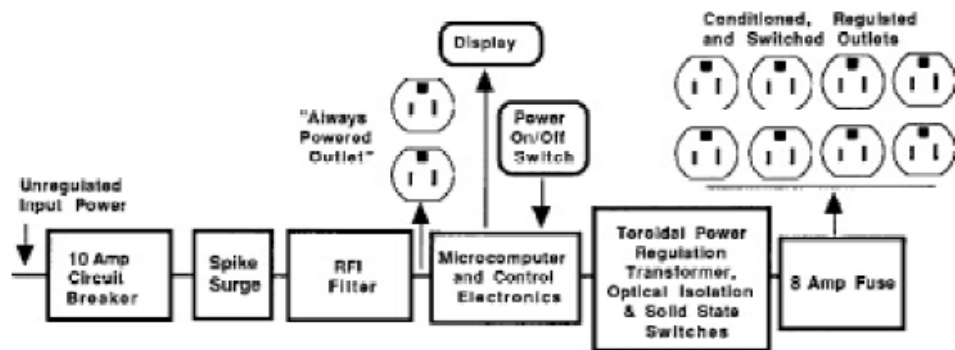

Back View



Fig. 4

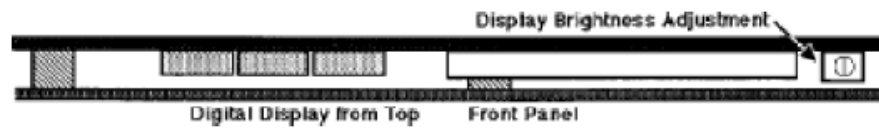
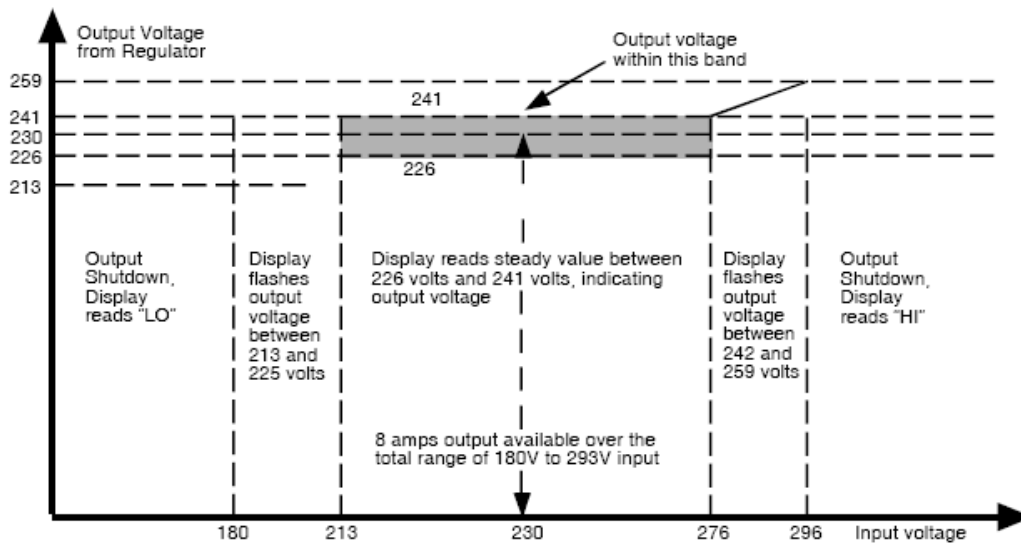

Fig. 3B

GRAPH FOR NOMINAL VOLTAGE OF 230 VOLTS / 50 HERTZ



ETA Conditioned Power Distribution... The Benchmark By Which Professionals Compare.

For over 20 years ETA has developed, manufactured, and sold high amperage theatrical lighting systems from which have evolved an extensive line of rack mounted conditioned power distribution products designed to protect today's sensitive electronic digital equipment.

The "PD" Conditioned Power Distribution Series easily deals with normal AC line power fluctuations, as well as the more drastic abnormalities of the spike and surge variety. Also, filtering of interferences caused by electromagnetic (EMI) and radio frequency (RFI) transmissions is routinely accomplished. More sophisticated ETA models utilize microprocessor technology to regulate AC power and sequence power turn-on— reducing high in-rushes of power.

ETA's sophisticated electronic protection technology is the favorite of professionals who demand flawless operation of digital mixers, processors, amplifiers and PCs—whether in the studio, in the boardroom, on tour, or in a home entertainment environment.



**Thank you for choosing ETA Systems
Power Distribution**

Your business is appreciated.

Call 1-800-321-6699 for an ETA Full Line
Brochure.



Power Conditioning Firsts from ETA

- "Always-On" Protected Outlets
- 10 Rear Panel Outlets
- Front Panel Convenience Outlets
- Digital Voltmeter Display Readouts
- Microprocessor Managed Voltage Regulators
- Programmable and Linkable Sequential Turn-on Models
- Models Adaptable for Multiple AC Adapters
- High Amp Conditioned Models
- Easy Bulb Change Feature

Standard on Every ETA Power Conditioning Model

- Spike and Surge Protection and EMI/RFI Filtration on All Three Legs of the Incoming AC Power—A Must to Ensure Protection of Electronic Components and Equipment.

Typical Uses

All Professional Permanent Installations, Recording Studios, Theatres, Schools, Clubs, Churches, any entertainment venue, business board rooms, and audio/ visual multi-use presentation rooms.

Portable Applications : On-The-Road Concert Tours, Bands, and D.J. services.

Other Important Applications: A/V racks, computer networks, and home entertainment centers.

1450 Lakeside Drive • Waukegan, Illinois 60085 USA
330-677-4424 • 800-321-6699 • Fax: 330-677-4471
<http://www.etasys.com> E-mail eta@etasys.com

All designs and specifications are subject to change without notice. Copyright © 2006 ETA Systems. 6MAN-027

Addendum

NOTE: The following pages are added as an addendum to the ETA manual. For most reliable performance of ETA Systems sequencing products, it is recommended that you use one of the cable types illustrated in the following pages. When installing any cabling in a plenum or return air space, it is the responsibility of the installer to ensure that Teflon jacketed cable is used where required by fire codes. ETA Systems assumes no responsibility for code violations or hazards that result from improper selection or installation of signaling cable.

8489 Non-Paired - Audio, Control and Instrumentation Cable

	<p>For more information please call 1-800-Belden1</p> <p><u>See Put-ups and Colors</u></p> <p>Related Documents : No. 1.pdf</p>
--	--

Description:

18 AWG stranded (19x30) tinned copper conductors, conductors cabled, PVC insulation, PVC jacket.

PHYSICAL CHARACTERISTICS:

CONDUCTOR:

Number of Conductors	4
Total Number of Conductors	4
AWG	18
Stranding	19x30
Conductor Material	TC - Tinned Copper

INSULATION:

Insulation Material	PVC - Polyvinyl Chloride
Nom. Insulation Wall Thickness	.017 in.

OVERALL CABLING:

Overall Cabling Lay Length	3 in.
Overall Cabling Twists/ft.	4

Overall Cabling Color Code Chart :

Number	Color	Number	Color
1	Black	3	Red
2	White	4	Green

OUTER SHIELD:

Outer Shield Material	Unshielded
-----------------------	------------

OUTER JACKET:

Outer Jacket Material	PVC - Polyvinyl Chloride
Outer Jacket Nominal Wall Thickness	.032 in.

OVERALL NOMINAL DIAMETER:

Overall Nominal Diameter	.257 in.
--------------------------	----------

MECHANICAL CHARACTERISTICS:

8489 Non-Paired - Audio, Control and Instrumentation Cable

Operating Temperature Range	-20°C To +60°C
UL Temperature Rating	60°C (UL AWM Style 2598)
Bulk Cable Weight	44.1 lbs/1000 ft.
Max. Recommended Pulling Tension	83 lbs.
Min. Bend Radius (Install)	2.6 in.

APPLICABLE SPECIFICATIONS AND AGENCY COMPLIANCE:

APPLICABLE STANDARDS:

NEC/(UL) Specification	CMG
CEC/C(UL) Specification	CMG
AWM Specification	UL Style 2598 (300 V 60°C)
EU CE Mark (Y/N)	Yes
EU RoHS Compliant (Y/N)	Yes
EU RoHS Compliance Date (mm/dd/yyyy):	04/01/2005

FLAME TEST:

C(UL) Flame Test	FT4
------------------	-----

PLENUM/NON-PLENUM:

Plenum (Y/N)	N
Plenum Number	88489, 82489

ELECTRICAL CHARACTERISTICS:

Nom. Capacitance Conductor to Conductor @ 1 KHz	26 pF/ft
Nom. Conductor DC Resistance @ 20 Deg. C	6.3 Ohms/1000 ft
Max. Operating Voltage - UL	300 V RMS (UL AWM Style 2598)
Max. Recommended Current	4 Amps per conductor @ 25°C

PUT-UPS AND COLORS:

Item	Description	Put-Up (ft.)	Ship Weight (lbs.)	Jacket Color	Notes
8489 060100	4 #18 PVC PVC	100	5.1	CHROME	
8489 0601000	4 #18 PVC PVC	1000	48	CHROME	C
8489 060250	4 #18 PVC PVC	250	12	CHROME	
8489 060500	4 #18 PVC PVC	500	24	CHROME	C
8489 060U1000	4 #18 PVC PVC	U1000	46	CHROME	
8489 060U500	4 #18 PVC PVC	U500	23.5	CHROME	

C = CRATE REEL PUT-UP.

Revision Number: 2 Revision Date: 05-16-2005

8489 Non-Paired - Audio, Control and Instrumentation Cable

© Copyright 2006 Belden, Inc
All Rights Reserved.

Although Belden ("Belden") makes every reasonable effort to ensure their accuracy at the time of this publication, information and specifications described herein are subject to error or omission and to change without notice, and the listing of such information and specifications does not ensure product availability.

Belden provides the information and specifications herein on an "AS IS" basis, with no representations or warranties, whether express, statutory or implied. In no event will Belden be liable for any damages (including consequential, indirect, incidental, special, punitive, or exemplary damages) whatsoever, even if Belden has been advised of the possibility of such damages, whether in an action under contract, negligence or any other theory, arising out of or in connection with the use, or inability to use, the information or specifications described herein.

All sales of Belden products are subject to Belden's standard terms and conditions of sale.

Belden believes this product to be in compliance with the following environmental regulations: California Proposition 65 Consent Judgment For Wire & Cable Mfgs. (San Francisco Superior Court Nos. 312962 And 320342); EU RoHS (Directive 2002/95/EC, 27-Jan-2003); Material manufactured prior to the compliance date may still be in stock at Belden facilities and in our Distributor's inventory. EU ELV (Directive 2000/53/EC, 18-Sept-2000); EU WEEE (Directive 2002/96/EC, 27-Jan-2003); And EU BFR (Directive 2003/11/EC, 6-Feb-2003). The information provided in this Product Disclosure, and the identification of materials listed as reportable or restricted within the Product Disclosure, is correct to the best of Belden's knowledge, information and belief at the date of its publication. The information provided in the Product Disclosure is designed only as a general guide for the safe handling, storage, and any other operation of the product itself or the one that it becomes a part of. This Product Disclosure is not to be considered a warranty or quality specification. Regulatory information is for guidance purposes only. Product users are responsible for determining the applicability of legislation and regulations based on their individual usage of the product.

Belden declares this product to be in compliance with EU LVD (Low Voltage Directive 73/23/EEC), as amended by directive 93/68/EEC.

COMMUNICATION & CONTROL

MULTICONDUCTOR, UNSHIELDED
PVC/PVC

UL TYPE CM
UL AWM 2509, CSA CMG FT 4
RoHS COMPLIANT, 300 VOLT

CHARACTERISTICS

OPERATING TEMPERATURE:

- -20°C to 80°C – AWM
- 75°C – CM

VOLTAGE RATING:

- 300 Volt – CM
- 150 Volt – CL2

COLOR DESCRIPTION:

- Color Code: Chart D Page 375
- Jacket Color: Gray

PRODUCT DESCRIPTION:

- Conductor: Stranded Tinned Copper
- Insulation: Color-Coded PVC
- Jacket: PVC

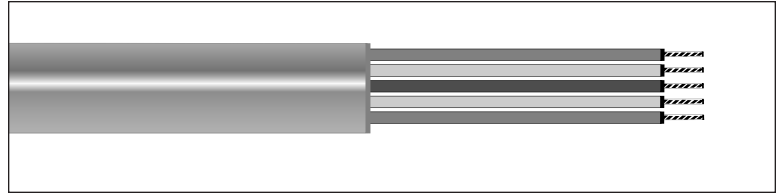

80°C 300V - UL 2509 - NEC TYPE CM

18 AWG (0,81mm²), 16/30 (16x0,25mm), Insulation Thickness: **0.016"** (0,41mm)

Alpha Part No.	No. of Cond.	Jacket Thickness		Diameter	
		Inches	mm	Inches	mm
1897C	2	0.020	0,50	0.20	5,0
1898C	3	0.020	0,50	0.21	5,3
1898/4C	4	0.020	0,50	0.24	6,1
1898/5C	5	0.020	0,50	0.26	6,6
1898/6C	6	0.020	0,50	0.29	7,4
1898/7C	7	0.020	0,50	0.29	7,4
1898/8C	8	0.025	0,63	0.31	8,0
1898/9C	9	0.025	0,63	0.34	8,8
1898/10C	10	0.025	0,63	0.37	9,4
1898/12C	12	0.025	0,63	0.38	9,8
1898/15C	15	0.030	0,76	0.44	11,3
1898/19C	19	0.030	0,76	0.47	11,9
1898/25C	25	0.035	0,88	0.56	14,1

80°C 300V - UL 2509 - TYPE CM

16 AWG (1,31mm²), 19/0.0117 (19x0,29mm), Insulation Thickness: **0.016"** (0,41mm)

Alpha Part No.	No. of Cond.	Jacket Thickness		Diameter	
		Inches	mm	Inches	mm
1899C	2	0.020	0,50	0.22	5,7
1899/3C	3	0.020	0,50	0.24	6,3
1899/4C	4	0.020	0,50	0.27	6,9

80°C 300V - UL TYPE CL2

14 AWG (2,08mm²), 41/30 (41x0,25mm), Insulation Thickness: **0.020"** (0,50mm)

Alpha Part No.	No. of Cond.	Jacket Thickness		Diameter	
		Inches	mm	Inches	mm
1891C	2	0.020	0,50	0.26	6,6
1891/3C	3	0.020	0,50	0.28	7,1

80°C 300V - UL TYPE CL2

12 AWG (3,31mm²), 65/30 (65x0,25mm), Insulation Thickness: **0.020"** (0,50mm)

Alpha Part No.	No. of Cond.	Jacket Thickness		Diameter	
		Inches	mm	Inches	mm
1892C	2	0.020	0,50	0.30	7,6
1892/3C	3	0.020	0,50	0.32	8,1

SPECIFICATIONS

- UL Type CM, AWM 2509 (18 & 16 AWG)
- UL Type CL2, (14 & 12 AWG)
- CSA CMG FT4 (18 & 16 AWG)
- CSA AWM I A/B, II A/B FT4 (14 & 12 AWG)
- Passes UL Vertical Tray Flame Test
- "C" Suffix Indicates CM or CL2 Rating as Applicable
- RoHS Compliant

UL LISTED Passes UL VW-1 Flame Test Underwriters Laboratories Inc. Certified Canadian Standards Association



AVAILABILITY

- 100 ft (30,5m), 500 ft (152m), 1000 ft (305m) put-ups



Toll Free: 1-800-52 ALPHA • Telephone: 908-925-8000 • Fax: 908-925-6923
Europe/UK Telephone: +44 (0) 1932 772422 • Europe/UK Fax: +44 (0) 1932 772433

Web Site: www.alphawire.com
Email: info@alphawire.com