

Power Protection Series PD11VBC Owner's Manual



Power Protection Series PD11VBC Owner's Manual

Congratulations on your selection of the PD11VBC as the AC power source for your audio/video system! Over 25 years of power protection experience and more than 10 years of Audio/Video noise filtration engineering experience were utilized in the

development of this model. The PD11VBC has been specifically engineered to enhance the performance and life expectancy of Audio/Video entertainment gear. The combination of sophisticated noise filtration circuitry and the world's finest surge protec-

tion has resulted in an Audio/Video power center that meets the power quality needs for each piece of equipment in your entertainment system. The styling of the PD11VBC complements even the most sophisticated Audio/Video showcase.



MODEL # PD11VBC



My PD11VBC power cable does not reach the wall outlet. Can I use an extension cord to make it reach?

Yes, but you must use only ETA extension cords to keep your warranty valid. Ask for part # GEC1410. (10 feet long) or #P12X10NEMA5-15.

Can the PD11VBC be mounted in an equipment rack?

An optional kit, #PD2MK, allows you to mount the unit in a standard 19" rack. The kit includes both brackets and screws.

The provided coax or telephone jumper cables are not long enough to reach my equipment. Can I use other cables?

Yes, any length cable of the same type meets the warranty requirements.

Outlet Bank 2 is not switching ON or OFF with the PD11VBC. How can I fix this?

These outlets may be set as either switched or Always-On outlets. The 3-position, Turn-Off Delay switch on the back panel controls this. Change the setting of this switch from Always-On to a delayed setting. This will allow the Outlet Bank 2 to become switched outlets.

The PD11VBC is ON but the Voltmeter is not lit up. What is the problem?

Check the Meter Light Dimmer control to see if the lighting is turned ON or OFF. If the control knob is turned OFF, turn it ON and continue turning until you have reached the desired light level. If the control knob is turned ON and there is no light, turn the knob to maximum. If you still have no light, call ETA Customer Service for help.

There was a lightning strike in my neighborhood and now my PD11VBC won't turn on. What is wrong?

The protection circuitry has done its job and protected your equipment from the lightning by sacrificing itself. Your PD11VBC will need to be repaired or replaced. Please refer to the preceding section on "Contacting ETA" or the warranty documentation for more information.

What is the difference between a Surge and Spike?

A spike is a high-energy pulse of electricity that lasts for short periods of time (a few milliseconds, 0.001 second) but can reach up to 6000 volts or higher. Nearby lightning strikes and ESD (Electrostatic Discharge) are the cause for most power spikes. A surge is similar to a spike, but will last for longer periods of time (15 milliseconds to 2.5 seconds) and reach up to 500 volts. Utility grid switching and motors turning on or off cause most power surges. Both surges and spikes are damaging to sensitive solid-state components present in Audio/Video equipment.

What is the difference between an Overvoltage and Undervoltage?

An overvoltage happens when power rises to an unsafe level (over 150 volts) for a long period of time (2.5 seconds to several hours). Overvoltages are usually caused by car accidents involving power poles, construction wiring accidents, wind and ice storms. An undervoltage (brownout) happens when power drops to an unsafe level (under 80 volts) for a long period of time (2.5 seconds to several hours). Undervoltages are usually caused by failures in the electric utility system or by very heavy power demands during a hot day. Both overvoltages and undervoltages will damage Audio/Video equipment power supplies.

What Does EMI and RFI stand for?

RFI (Radio Frequency Interference) and EMI (Electromagnetic Interference) refer to high frequency signals emitted through the air and induced into AC power lines. Audio/Video equipment will pick up these signals and generate enough noise to degrade picture and sound quality.

Before You Begin.....	1	Voltage Sense Trigger.....	8
Introduction.....	2	Circuit Breaker.....	8
Connection Diagram.....	3	Coaxial Line Protection.....	9
Feature Overview.....	4	AC Power Cord.....	9
Feature Details		Telephone Line Protection.....	9
Voltmeter.....	5	AC Surge Protection.....	10
Convenience Outlet.....	5	Technical Specifications.....	11
Diagnostic Lights.....	6	Contacting ETA.....	11
Sequential Startup/Shutdown.....	6	Frequently Asked Questions.....	12
Filtered Outlet Banks 1 & 2.....	7		
High-Current Outlet Bank.....	8		

BEFORE YOU BEGIN

Items included with the PD11VBC:



1 - PD11VBC



4 - Coax Cables for Satellite TV, Cable TV and/or Antennas

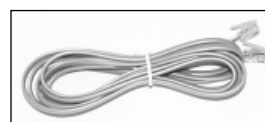

1 - RJ-11 Telephone Cable



1 - IEC 320, 120V/15A 10 ft. power cord

Please verify that you have received all these items. If not, contact ETA.

INTRODUCTION

Your Audio/Video components are constantly being bombarded by electromagnetic interference (EMI) and radio frequency interference (RFI) through their power cords. This contaminated power can affect A/V equipment and will degrade the overall performance of your entire system. Common symptoms of contaminated power include pops, hisses, hums, visual artifacts, etc. Most power filtering devices will remove some of this interference but don't provide a real solution to the problem.

The PD11VBC Sophisticated Filtration System is a Real Solution!

Outlet Banks 1 & 2:

The primary filtration system features two banks of independently filtered outlets (4 per bank) for A/V equipment. These outlet banks utilize "Balanced Double L" filter circuits which are far superior to any other design in filtering out all forms of electromagnetic and radio frequency interference in both common and normal modes. Cross-contamination between your components is also eliminated with this design. Bank 1 is Always-On, providing continuous power for those components that have programmable memory settings. Bank 2 can be set to either Always-On or switched with a shutdown delay.

High-Current Outlet Bank:

The unique power requirements of current hungry components such as amplifiers and powered subwoofers are also addressed. These components can rapidly draw large amounts of current to replenish their power supply capacitors after thunderous bass notes. Line conditioners that utilize coils (inductors) in series with the AC power line can "choke" off this large inrush current, thereby reducing the amplifiers' ability to operate at peak performance levels, resulting in a flat, dead sound. The PD11VBC high-current outlets are fed by noise filtration circuitry that does not utilize coils and provides full, unimpeded power for your amplifiers and powered subwoofers.

Other Features Enhance the Functionality:

Although the PD11VBC functionality revolves around noise filtration and power protection, many other exciting features enhance the overall entertainment experience, including:

- A backlit analog voltmeter indicates the AC line voltage coming into your system.
- A combination ON/OFF/Dimmer switch controls the meter lighting.
- An always-on, convenience outlet on the front panel for temporary AC connections.
- Sequential start-up and shut-down of your system using an A/V receiver (or other component) and the 12VDC trigger input.

As you read through the rest of this manual, you'll discover many more unique features. As audiophiles, we care about the quality of your listening and/or viewing experience. Our goal is to:

- Provide clean pure power
- Protect your investment
- Enhance the pleasure you get from your A/V system

Thank you for choosing ETA for your power quality needs. Please finish reading the instructions, install your PD11VBC and enjoy the full potential of your entertainment system.

TECHNICAL SPECIFICATIONS

GENERAL

Dimensions.....17" W x 12" D x 3.5" H, (4.1" Including Feet)
Weight.....16 lbs.

AC CIRCUIT

NOISE FILTRATION:

Filtered Outlet Banks.....55 dB (100 KHz - 1 MHz)
High-Current Outlets.....50 dB (100 KHz - 1 MHz)

SURGE PROTECTION:

UL 1449 Surge Suppression Rating.....330V
Protection Modes.....L - N, L - G, N - G
Initial Clamping Level.....200V Peak, 141V Rms
Response Time.....<1ns
Joule Rating.....1790 Joules
Peak Impulse Current.....65,000A
Catastrophic Surge Circuit.....YES

AC:

Line Voltage.....120VAC
Max Current Rating.....15A (1800 Watts)
Thermal Fuse.....YES
Over/Under Voltage Protection.....YES
Over-voltage shutoff threshold.....137±4 VAC, 10 Milliseconds
Under-voltage shutoff threshold.....95±4 VAC, 500 Milliseconds

Design and specifications subject to change without notice due to product improvement.

DC TRIGGER

Connection.....3.5mm mono mini-plug
Voltage and Polarity.....3-18VDC nominal, bi-directional
Current Requirement.....25mA

SATELLITE CIRCUIT

Clamping Level.....27V
Attenuation.....<1 dB from 950MHz - 2.2GHz
Shielded.....YES
Connections.....Gold plated, Female "F"

ANT/CATV CIRCUIT

Clamping Level.....0.7V
Attenuation.....<1 dB from 5MHz - 950MHz
Shielded.....YES
Connections.....Gold plated, Female "F"

TELEPHONE CIRCUIT

Clamping Level.....260V
Capacitance.....30pf (approx.)
Suppression Modes.....Metallic & Longitudinal
Wires Protected.....2 wire/ 1 pr. (pins 4,5)
Fuseless/Auto-Resetting.....YES
Connections.....RJ-11/45

CONTACTING ETA

For product and warranty information, dealer information, and other general information contact Customer Relations at:

- Email: eta@etasys.com
- www.etasys.com
- Fax 330-425-9700
- 800-321-6699 or 330-425-3388, 7:30 a.m.- 5:30 p.m. EST

FEATURE DETAILS

The PD11VBC provides protection against common problems on the AC power lines. This includes spikes/surges and sustained overvoltages or undervoltages. The circuitry is designed to protect against spikes/surges and special circuitry is for sustained over/under voltage protection.

AC Surge Protection

When the PD11VBC is subjected to a high voltage surge, its voltage output is limited to a safe level and the high levels of surge current are diverted away from the connected equipment.

- When subjected to a 6,000V (open circuit voltage) / 500A (short circuit current) surge, the PD11VBC limits its voltage output to less than 330V peak, UL's lowest rating. The PD11VBC will withstand, without damage, multiple 12,000A surges, far exceeding the UL maximum requirement of only 3,000 Ampere surges.
- If the magnitude of the surge is greater than the capacity of the surge protection components, the PD11VBC's circuitry will disconnect your equipment in order to protect it. The PD11VBC will need to be repaired or replaced by ETA if this occurs.

The PD11VBC constantly monitors the AC line voltage for unsafe voltage conditions such as prolonged overvoltages and undervoltages (brownouts). These unsafe conditions pose a very dangerous threat to all electronic equipment within the home. If the PD11VBC senses an unsafe power condition, it will automatically **disconnect** your equipment from the power to protect equipment from damage. Once the voltage returns to a safe level, the PD11VBC will automatically **reconnect** the power.

If the line voltage exceeds the overvoltage threshold (137VAC) or falls below the undervoltage threshold (95VAC), the PD11VBC will perform the following tasks until line voltage returns to a safe level:

1. Disconnects power to all connected equipment.
2. Unsafe Voltage LED is activated and will blink once per second during the unsafe voltage condition.

The PD11VBC requires line voltage to return to within the safe operating range for 10 seconds before returning to normal operating mode. This is referred to as "Over/Undervoltage Recovery". The safe operating range is considered 5V above the undervoltage threshold (-100V) and 5V below the overvoltage threshold (-132V). Once this safe operating range is reached, the PD11VBC will perform the following functions:

1. Unsafe Voltage LED will blink 4 times per second for Over/Undervoltage Recovery.
2. Power is restored to all connected equipment after the 10-second delay. The normal start-up sequence as determined by the "High-Current Outlets Turn-On Switch" and "Outlet Bank 2 Turn-Off Switch" will be followed.



1. Voltage reaches an unsafe level.

2. If surge is greater than PD11VBC capacity, it disconnects.

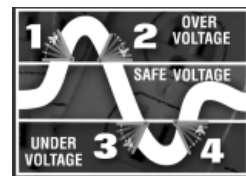

1. Voltage reaches an unsafe high level and the PD11VBC disconnects.

2. Voltage reaches a safe level and the PD11VBC automatically reconnects.

3. Voltage reaches an unsafe low level, the PD11VBC disconnects.

4. Voltage reaches a safe level and the PD11VBC automatically reconnects.



CONNECTION DIAGRAM

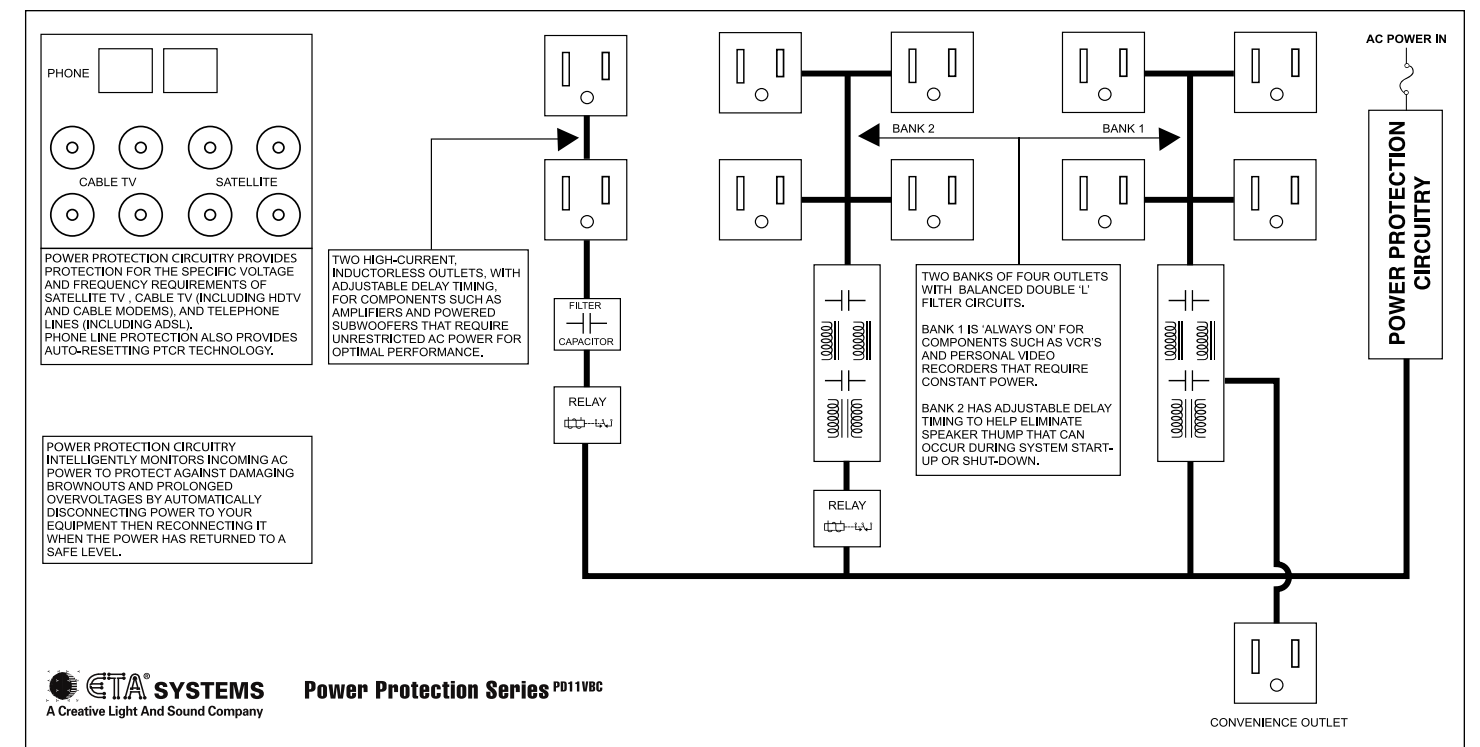
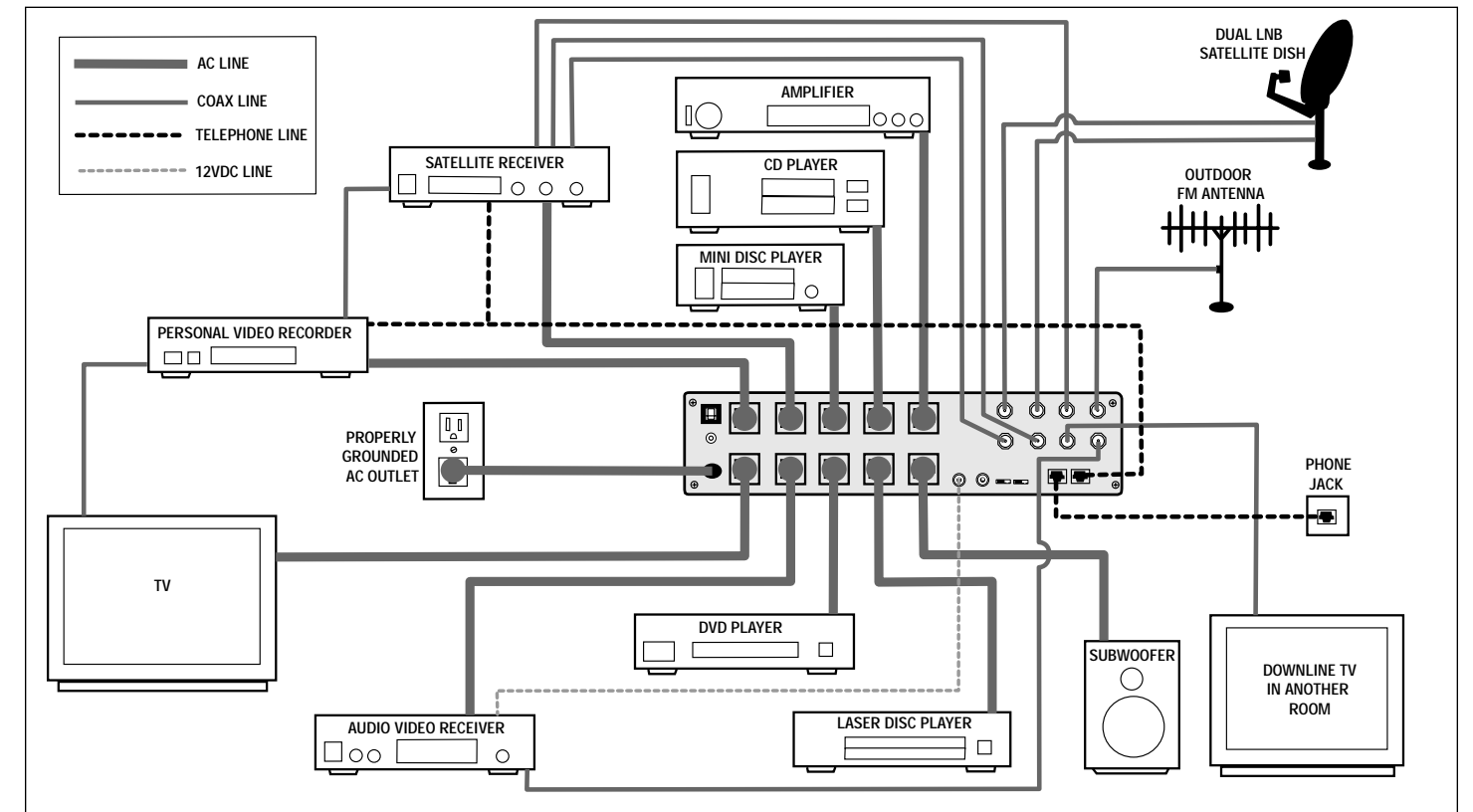

ETA SYSTEMS Power Protection Series PD11VBC
A Creative Light And Sound Company

FEATURE OVERVIEW

Switched Outlets Pushbutton:
1 of 2 Triggers that can activate a turn-on or shutdown sequence for Outlet Bank 2 and High-Current outlets.

LED Indicators:
Status indicator lights for Switched Outlets, DC Voltage Trigger, Ground OK, Line Fault and Unsafe Voltage

Meter Light Dimmer:
Controls brightness of the Voltmeter backlighting.

Voltmeter:
Backlit analog meter measures incoming voltage source from 0-150 VAC.

Convenience Outlet:
Provides a quick convenient way to plug in components such as camcorders and video game systems.



15A Circuit Breaker:
Opens in the event that equipment plugged into the PD11VBC draws too much current. When the white button of the breaker is visible, the breaker has opened. Reduce the load and push to reset.

Filtered Outlet Bank 1:
Four Always-On, Balanced Double L filtered outlets for audio/video components that require constant power to maintain programmed settings.

Filtered Outlet Bank 2:
Four switched, Balanced Double L filtered outlets for audio/video components that do not require constant power.

High-Current Outlet Bank:
Two delayed outlets designed for high-current components such as amplifiers and powered subwoofers. The current available to connected equipment is not limited by the noise filtration components.

Satellite Coax Jacks:
Two pairs of gold plated F-Connectors optimized for Satellite TV signal line protection.

Cable TV Coax Jacks:
Two pairs of gold plated F-Connectors optimized for Cable TV and non-amplified Rooftop Antenna signal line protection.

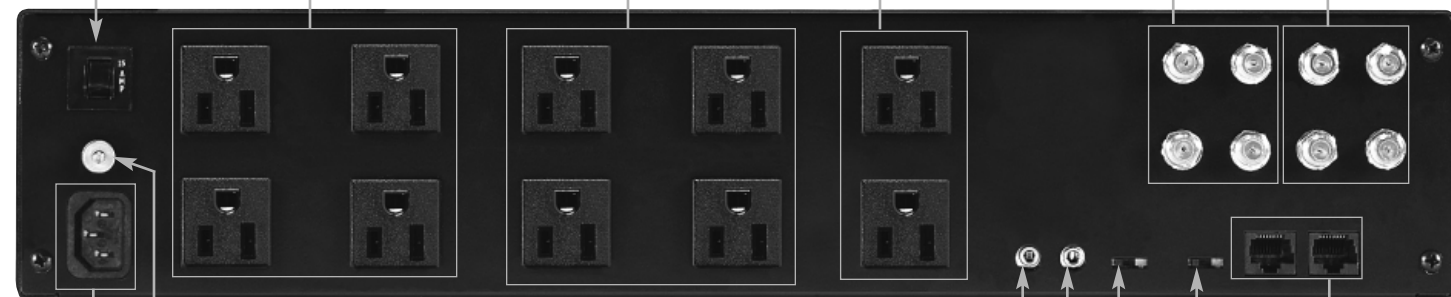

IEC Main Power Receptacle:
Power cord connects to this receptacle.

Ground Lug:
Provides a common grounding point for equipment with separate ground leads.

Voltage Sense Trigger Input:
1/8 inch Mini-Plug jack. Connect to a remote trigger device that provides 12VDC to trigger a startup/shutdown sequence. This is the second trigger that will activate the PD11VBC turn-on or shutdown sequence. (See switched outlets pushbutton on front panel).

Voltage Sense Trigger Output:
1/8 inch Mini-Plug jack. Connecting a 12VDC trigger to the Voltage Sense Circuit will allow the same signal to pass through the Voltage Sense Output to control the startup/shutdown of an additional device.

High-Current Outlets Turn-On Switch:
3-position slide switch. Allows adjustment of the Turn-On delay for the two High-Current Outlets. Choose between 0, 10 and 30 seconds.

Outlet Bank 2 Turn-Off Switch:
3-position slide switch. Allows adjustment of the Turn-Off delay for Outlet Bank 2. Choose between Always-On, 10 and 30 seconds.

Telephone Jacks:
In/Out connections for telephone line or pay-per-view line protection.

FEATURE DETAILS

Coaxial Line Protection

All coaxial cable sheaths from outdoors must be grounded to the building grounding electrode system where they enter the building (per applicable NEC/CEC code). A driven ground rod is not adequate.

The PD11VBC provides application-specific protection for your satellite and cable TV equipment. Two lines of protection are provided for each type. The satellite connections are for coaxial cables connected to a DBS (single or dual LNB) satellite dish. The antenna connection is for a non-amplified rooftop antenna or cable TV line. The Additional TV connection protects the equipment plugged into the PD11VBC from "backdoor" surges in situations where the video signal runs to another room for a downline TV.

Cable TV (Including HDTV) – TV tuners operate at approximately 10 millivolts (0.01 V) and utilize the frequency spectrum of 50Mhz to 950Mhz. The clamping level of the PD11VBC's cable TV protection circuitry is 700 millivolts (0.7 volts). That's less than 1 volt above normal operating levels. The circuitry is shielded to prevent interference and has been optimized to have less than 1dB of signal loss throughout the entire 50Mhz to 950Mhz range.

Satellite - Satellite dish LNB's can require up to 24 volts to operate and utilize the frequency range of 950Mhz to 2.2Ghz. The clamping level of the PD11VBC's satellite protection circuitry is 27 volts - just 3 volts above the maximum operating voltage. The circuitry is shielded to prevent interference and has been optimized to have less than 1dB of signal loss throughout the entire 950Mhz to 2.2Ghz range.

Telephone Line Protection

Satellite TV receivers require a telephone line connection for Pay-Per-View services. The PD11VBC also provides surge protection for this line. One pair of RJ-11/45 compatible telephone jacks is provided for this. The circuitry utilizes auto-resetting PTCRs and solid-state SIDACTors™ for reliability and unsurpassed protection. The clamping level of the PD11VBC's telephone protector is 260 volts. This will allow typical ring voltage (90-130VAC) and operating battery voltage (-48DC) to pass through the circuit and still protect the modem in your satellite receiver from damage.

Please note: *The protection circuitry will not work if the phone lines are reversed. The incoming phone cable must be connected to the "LINE" jack and the cable to the audio/video equipment must be connected to the "EQUIP" jack.*

Power Cord

The PD11VBC comes equipped with a UL recognized, 10 foot, IEC320 power cord rated for 120V, 15-Amps, minimum 14 gauge wire and the cord secured to the enclosure with a cord retention bracket. The cord is not intended to be removed.

FEATURE DETAILS

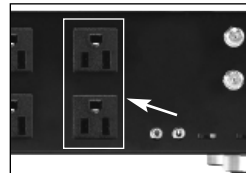

High-Current Outlet Bank

The two high-current outlets allow amplifiers and powered subwoofers to work to their full potential. When the movie thunders with a terrific explosion or when the music reaches a climactic crescendo, an amplifier has to rapidly draw large amounts of current to replenish its power supply capacitors. Traditional line conditioners impede this current draw, in effect, starving an amplifier and resulting in a flat, dead sound. The High-Current Outlet Bank provides clean, filtered power to amplifiers but has no current limiting components to impede performance.

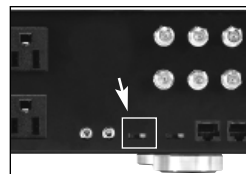

The high-current outlets are designed with a turn-on delay option of 0, 10 or 30 seconds. The 3-position, Delayed Outlet Turn-On Switch on the back of the PD11VBC is used to select the desired time delay. When a delay is selected, the high-current outlets will turn-on after Outlet Bank 2 and turn-off before Outlet Bank 2 (if they're not set to Always-On). With a delay, the connected equipment will not power up simultaneously, thus preventing loudspeaker noises such as "thumping". See the [Sequential Startup/Shutdown](#) section for more information.

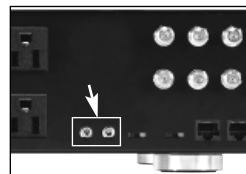

Voltage Sense Trigger

This feature provides an ON/OFF trigger for the PD11VBC using a DC remote control signal. Many components such as pre-amplifiers and receivers have a 12VDC trigger built in, and will transmit a constant power signal when turned on and in use. This power signal will initiate the startup or shutdown sequence of the PD11VBC's switched outlets. An AC Adapter of the appropriate voltage, plugged into a switched outlet, may also be used if a 12V trigger is not built in.

The PD11VBC voltage sense trigger input uses a standard 1/8" mini-plug jack. This jack has an electrically isolated switch built in. If nothing is inserted into the input jack, the voltage sense is bypassed and the PD11VBC Switched Outlets button on the front panel has sole control of the startup/shutdown sequence. If a plug is inserted into the input jack, the voltage sense becomes the startup/shutdown trigger. *Please note: The Switched Outlets pushbutton on the front panel must be left in the "ON" position if you are using the DC trigger.*

The circuitry for the voltage sense trigger also controls the DC Voltage Trigger diagnostic LED on the front panel. When a 1/8" mini-plug is connected to the voltage sense input jack and a DC voltage signal is present, the LED will light to indicate that the voltage sense circuit is ON and the PD11VBC's switched outlets are ON. When the diagnostic light is not lit, the source component is turned off and there is no DC signal.

The PD11VBC also has the ability to pass through the DC signal from the voltage sense trigger to another slave device. *Please note: The Voltage Sense Trigger Output will not operate unless the Voltage Sense Trigger Input is connected to a source.*

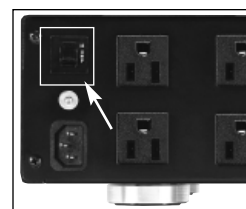

Circuit Breaker

A circuit breaker is located on the back panel of the PD11VBC. The circuit breaker will trip only if the total current draw exceeds the maximum current rating (15A). This means that collectively, all outlets must draw more than 15 Amps before the circuit breaker will trip.

FEATURE DETAILS



Voltmeter

The analog Voltmeter is backlit to provide the ability to view the reading in a dark room. LEDs (light emitting diodes) are used as the light source in order to provide durability and long life. The "Meter Light" dimmer controls the brightness level, or turns the lighting off altogether.

The Voltmeter monitors the incoming voltage from the wall receptacle and provides a visual representation of the available power. The voltmeter is ALWAYS-ON and indicates the incoming line voltage even during an unsafe voltage condition. Readings above 150VAC will not be accurate due to the meter's damping characteristics.



Convenience Outlet

A single outlet on the front panel of the PD11VBC provides an easy to reach power source for electronic equipment typically used on a part time basis. Such equipment includes anything from video game systems to camcorders.

The convenience outlet not only provides superior surge suppression, but also taps into one of the Balanced Double L Filter Circuits to provide clean power for your sensitive electronic equipment. This outlet is an Always-On outlet and will continually supply a steady source of power for your connected equipment. *It is important to remember that power will be disconnected only in the event of an unsafe voltage condition.*

FEATURE DETAILS



Diagnostic Lights

The PD11VBC is loaded with special features to save your connected equipment from many different forms of dangerous power disturbances. Five diagnostic lights on the front panel inform you in the event of a power disturbance or when a special feature is activated. The indicators are:



Switched Outlets: Green LED. This light indicates the status of the "Switched Outlets" pushbutton on the front panel and corresponds with the switch position. When the button is in the "ON" position, the light is ON. When the button is in the "OFF" position, the light is OFF. "Switched Outlets" refers to Outlet Bank 2 and the High-Current Outlets. See their respective sections for switching options.



DC Voltage Trigger: Green LED. This light indicates status of the DC voltage trigger on the back panel of the PD11VBC. The light is ON when the DC voltage trigger is activated and OFF when the DC voltage trigger is not receiving a signal. This light will also be ON if nothing is plugged into the DC voltage trigger input jack. This indicates that the DC voltage trigger is being bypassed.



Ground OK: Green LED. When this light is ON, it indicates that the wall outlet is properly wired. When the light is OFF, it indicates that the wall outlet has reversed line and neutral wires, or that there is no ground present.



Line Fault: Red LED. When this light is ON, it is indicating that the wall outlet has a reversed line and neutral wire, or there is no ground present. This light will remain OFF if the wall outlet is properly wired.



Unsafe Voltage: Red LED. Under normal voltage conditions, this light stays OFF. When this light is FLASHING slowly (once per second), it indicates an undervoltage (<95 VAC) or overvoltage (>137 VAC) condition. When the light is flashing quickly (4 times per second), it indicates a 10 second recovery period from an under/overvoltage condition. This light will flash quickly when the PD11VBC is first plugged into the wall outlet.

Sequential Startup/Shutdown

Complex audio/video systems may be susceptible to voltage transients generated internally at start-up/shutdown if all of the equipment is powered on or off at the same time. This can cause speaker "thumps" which are not only annoying but can also damage the speakers. The PD11VBC is designed to eliminate these transients by providing a "start-up" delay for the High-Current outlets and a "shutdown" delay for Outlet Bank 2. This allows the components plugged into the switched outlets to power-up and stabilize before any amplifiers and powered sub-woofers are turned on. This sequence is reversed during shutdown. The amplifiers and powered sub-woofers turn off, their power supplies drain, then the equipment plugged into Outlet Bank 2 is turned off.

Information on setting the delay times is included in the [Outlet Bank 2](#) and [High-Current Outlet Bank](#) sections that follow.

FEATURE DETAILS

Filtered Outlet Banks 1 & 2:

Eight Outlets (two banks / four outlets per bank) are fed through separate "Balanced, Double L" noise filtration circuits. These circuits are designed to eliminate AC contamination that is detrimental to the performance of audio or video components like stereo receivers, VCRs or televisions. The two dedicated filters are carefully engineered to provide power filtration and inter-component "noise isolation" for both "common mode" (line/neutral-to-ground) and "normal-mode" (line-to-neutral) EMI/RFI. This means that high-frequency interference will be drastically reduced not only from the incoming power but also from equipment plugged into the other outlet bank, regardless of what "mode" it occurs in. Even equipment with ungrounded, 2-blade plugs, receives clean power.

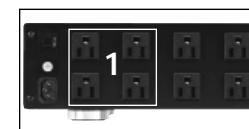

Outlet Bank 1 remains ON continually to provide a constant power source for programmable audio/video components. A personal video recorder (such as TiVo™) and VCR are two examples of components that require a constant supply of power. A TiVo™ video recorder relies on continual power to monitor the cable signal and retain its programmed information. A VCR should be connected to one of these always-on, filtered outlets to maintain correct clock time and programmed recording information.

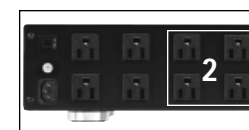

Outlet Bank 2 contains four switched outlets that will turn your connected equipment ON or OFF with one of two PD11VBC triggers (Switched Outlets push-button or Voltage Sense Trigger). A 3-position slide switch (Outlet Bank 2 Turn-Off Switch) located on the rear panel controls the timing for Outlet Bank 2. Together, these outlets can be set as Always-On or with a turn-off delay of either 10 or 30 seconds to prevent speaker "thump". This switch provides the option of having a total of eight always-on outlets (Outlet Banks 1 & 2). See the Sequential Startup/Shutdown section for more information.

When set to one of the delay positions (10 or 30 seconds), Outlet Bank 2 outlets will remain as Switched outlets, controlled by the Switched Outlets push-button and/or the DC Voltage Sense Trigger. In this situation, Outlet Bank 2 outlets will not power down until after the selected time has elapsed.