

General Specifications - Model CPC65.0-XD20Y

| | |
|---|--|
| Input Voltage | 208/240/480/600 delta connection (4 wire) |
| Output Voltage | 208/120 wye (5 wire) |
| Frequency | 60 Hz. only |
| Continuous Capacity | 65 kVA |
| BTU/Hr. Output | 3329 |
| Efficiency | >98.5% (at full load, unity power factor) |
| Step Load Change | ± 0.8% (at unity power factor) |
| Noise Rejection | With unit under power and the isolation transformer configured for a transformation ratio of 1:1 and with an ANSI/IEEE C62.41, Category A pulse applied either normal mode or common mode at the input, the noise output voltage will be less than 10 volts normal mode (-60 db) and less than .5 volts (½ of one volt) common mode (greater than -80 db from 1 Hz to 5 MHz) in all four quadrants (CM-NM, NM-NM, CM-CM, NM-CM). |
| Surge Voltage Withstand | Tested under power to ANSI/IEEE C62.41, Category A & B (formerly IEEE587-1980). Power conditioner tested to withstand up to 6000 volts @ 3000 amp ringwave and unipolar impulse. |
| Construction Materials | Transformer wires are copper and insulated with Class H materials. Windings are insulated with Nomex paper insulation before vacuum varnishing. Internal wiring is a minimum of 200 degree C rated and sleeved with Class H materials. Grain oriented silicon iron cores are constructed using 14 mil. laminations interleaved one to one. Eddy currents are minimized and external magnetic fields are below 0.1 oersted (at 12 inches distance in any direction). Complies with RoHS directives. |
| Physical Dimensions H x W x D - inches (mm.) | 47 x 22 x 39 (1194 x 559 x 990) |
| Weight in lbs. (kg.) | 1250 (568) |

Input Connection Requirements*

| Input Voltage | Input Current (FLA) | Supply Breaker Rating @ Switchgear | AIC (Current Interrupt Capacity of Input Circuit Breaker) | Minimum Input Conductor Size (includes ground) | Input Lug Maximum Wire Size |
|---------------|---------------------|------------------------------------|---|--|-----------------------------|
| 208 | 180 | 225 | 25 kAmps | 3/0 | 250 kCMIL |
| 240 | 157 | 200 | 25 kAmps | 3/0 | 250 kCMIL |
| 480 | 78 | 100 | 25 KAmps | 3 AWG | 250 kCMIL |
| 600 | 63 | 80 | 25 kAmps | 4 AWG | 250 kCMIL |

* Supply breaker ratings are determined by NEC guidelines limiting breaker loading to 80% of rated breaker capacity. Calculations for supply breaker recommended ratings are based on input full load amps multiplied by 1.25 and then selecting the next larger standard size breaker. Wire sizes shown in the input and output connection tables of this specification sheet are the minimum sizes allowed by electrical codes for each supply breaker rating and are taken from the 2002 National Electrical Code Article 310.16 table references for use in 90° C installations.



Output Connection Requirements*

| Output Voltage | Output Current (FLA) | Minimum Output Conductor Size (includes ground) | Output Lug Maximum Wire Size |
|----------------|----------------------|---|------------------------------|
| 208/120 | 181 | 2/0 | 2/0 |

Breaker Trip Current Programming (when applicable)

Some models of power conditioner may support an optional programmable circuit breaker. If so equipped reconfiguring the settings of a programmable circuit breaker (when required) is accomplished by changing the settings of DIP switch pack **I1** on the front of the circuit breaker. Each circuit breaker has a maximum ampacity rating, and the DIP switches may be set to program the circuit breaker to trip at increments of 100%, 95%, 90%, 80%, 70%, 60%, 50%, and 40% of the breaker’s maximum input ampacity as shown to the left below. The input circuit breaker of each model of CPC is programmed for the appropriate trip current as determined by the input voltage available at the installation site. Consult the following table.

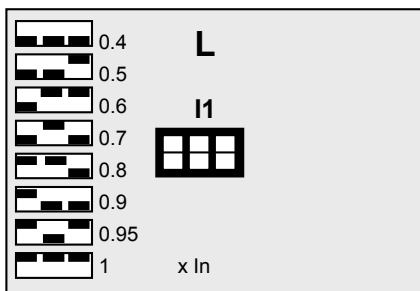

| Input Voltage (L-L) | Breaker Frame ID | Breaker Setting In amps | L1 DIP Switch Setting |
|---------------------|------------------|-------------------------|-----------------------|
| 208 | S4 | 175 | |
| 240 | S4 | 150 | |
| 480 | S4 | 80 | |
| 600 | S4 | 70 | |

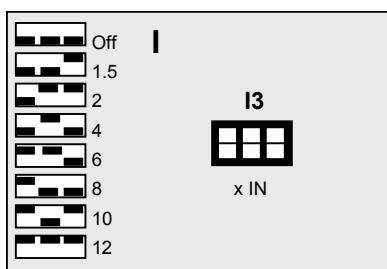

DIP switch pack **I3** defines the circuit breaker’s inrush current capability. **I3** consists of three DIP switches, which allow the breaker to be programmed to accommodate inrush current characteristics from zero to twelve times its rated steady state ampacity as shown to the left. The CPC utilizes a low impedance isolation transformer, which, when energized, results in substantial short-term inrush current. **I3** DIP switches are factory set so that the circuit breaker is configured for maximum inrush current capability. ETA Systems recommends that these settings not be changed without first consulting ETA Technical Support.

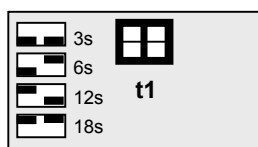

DIP switch pack **t1** determines the circuit breaker’s response time to an overload condition. Response times of three seconds, six seconds, twelve seconds, and eighteen seconds may be selected as shown to the left. The **t1** DIP switches are factory set for a response time of eighteen seconds. ETA recommends that these settings not be changed without first consulting ETA Technical Support.

| VAC | Connect each phase |
|-----|---------------------------------------|
| 208 | H1 to H3-4, H2 to H1-4 and H3 to H2-4 |
| 240 | H1 to H3-3, H2 to H1-3 and H3 to H2-3 |
| 480 | H1 to H3-2, H2 to H1-2 and H3 to H2-2 |
| 600 | H1 to H3-1, H2 to H1-1 and H3 to H2-1 |

H1, H2, H3 TO THE MAIN INPUT
CIRCUIT BREAKER

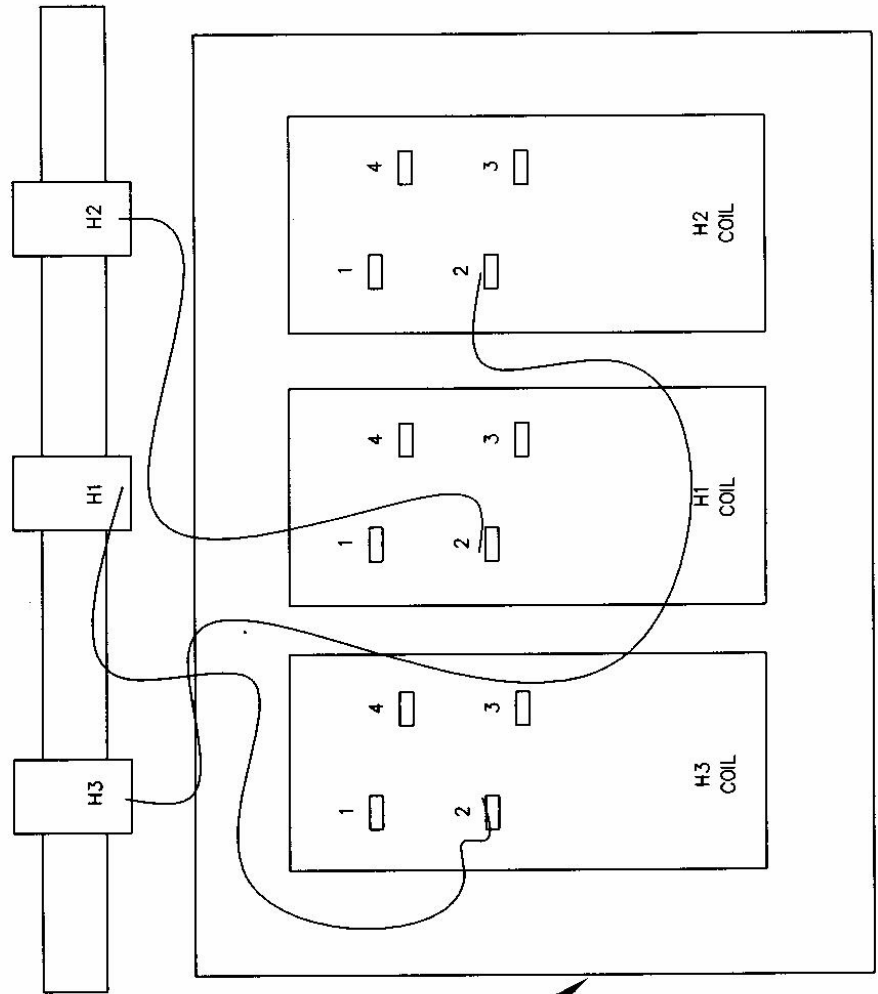

Transformer Primary Connections

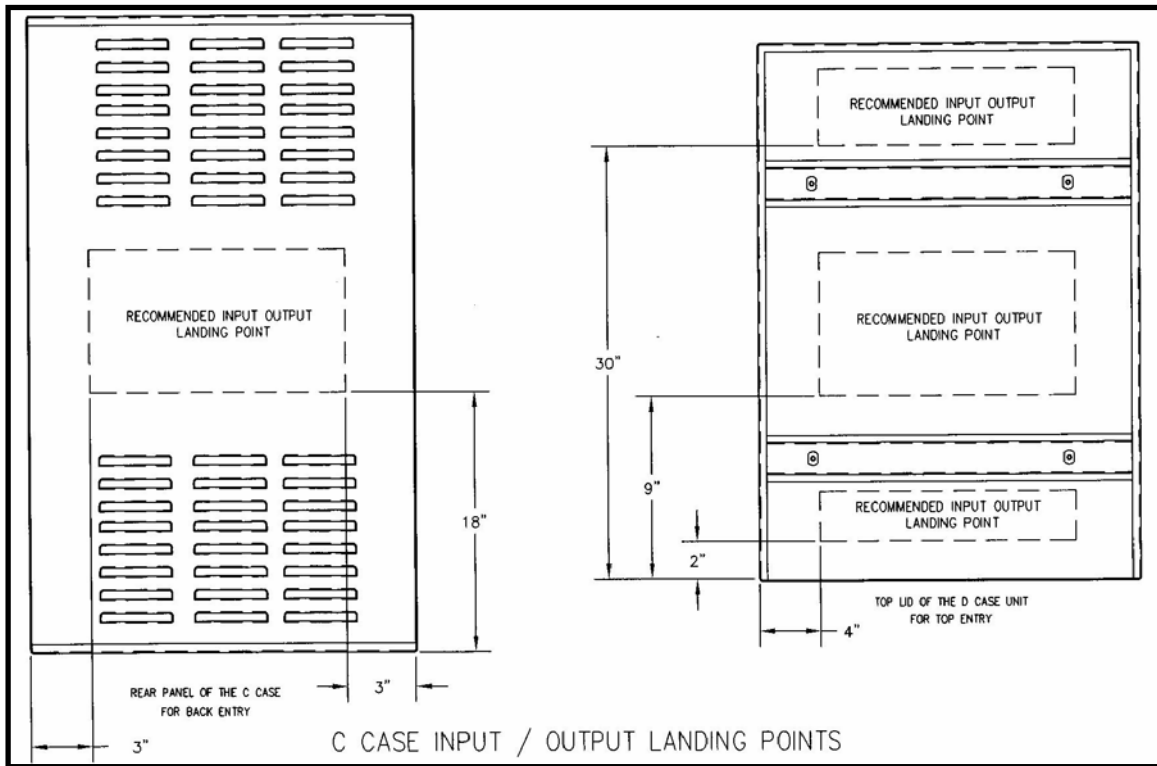

1.5" Sq. x .187" Wall Tube is welded to bottom panel of cabinet frame

5/16-18 x2.5" Grade 5 Bolts

3/8-16 Grade 5 Bolt

22.5

11.68

Seismic Anchorage Data

Max total weight in lbs. (kg.) = 1200 (545.5)

Max. weight per foot in lbs. (kg) = 437 (198.6)

39.20

46.75

20.35

17.5

7.3

24.0