



EFT-900A

*Installation and
Operations Manual*

EFT-900A Installation and Operations Manual

Copyright© 1993 by Gentner Communications Corporation. All rights reserved. No part of this manual may be reproduced in any form or by any means without permission from Gentner Communications Corporation.

Printed in the United States of America. Gentner Communications Corporation reserves specification privileges.

Information in this manual is subject to change without notice.

This manual was written and designed by Renee Gibson.

*Gentner Part No. 800-057-001
December 1993*

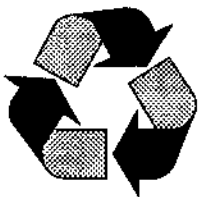

Gentner Communications Corporation is committed to protecting the environment and preserving our natural resources.

This manual has been printed entirely on recycled paper.

INTRODUCTION

Thanks for your purchase of an EFT-900! We're confident that this product will give you many years of dependable, profitable service. This manual is intended to give you all the information needed to use and operate the unit. In addition, we've provided application notes so you can get full use of your EFT-900.

Table of Contents

Introduction.....	Page 1
Table of Contents.....	Page 1
Specifications.....	Page 1
Warranty.....	Page 2
How to Operate the EFT-900	Page 3
Block Diagram and Functional Description.....	Page 5
Installation and Options.....	Page 7
Applications.....	Page 9
Quick Reference.....	Page 14

Specifications (Subject to change without notice.)

Power	120/240 VAC 50/60 Hz 6 Watts
Battery	Wall Transformer Included Optional
Input	Mic. -55 dBm 150 ohms Balanced Line 0 dBm 600 ohms Balanced Aux 0 dBm 10K ohms Unbalanced
Encoder	Freq Response 50 Hz - 3500 Hz <u>±</u> .5 dB Freq Shift +250 Hz Comrex (r) Compatible Distortion .1% THD S/N Ratio 50 dB
Output	-15 dBm into Telephone Line 0 dBm to XLR Output Jack
Decoder	Input -35 dBm from Telephone Line Freq Response 50-3500 Hz <u>±</u> 5 dB on Freq Shift -250 Hz Comrex (r) Compatible Distortion .1% S/N Ratio 50 dB

Warranty

Your satisfaction is the measure of our success. If you are not totally satisfied with this product, please call Russ Gentner direct at (801) 975-7200 so that he can resolve the problem. We're committed to your satisfaction.

GENTNER ENGINEERING COMPANY warrants that this product is free from defects in both materials and workmanship. Should any part of this equipment be defective, Gentner Engineering Company agrees, at its option, to:

A. Repair or replace any defective part free of charge (except transportation charges) for a period of one year from the date of the original purchase, provided the owner returns the equipment to Gentner Engineering Company at the address set forth below. No charge will be assessed for parts or labor during this period.

B. Replace or furnish replacement for any defective parts in the equipment for a period of one year from the date of original purchase. Replacement parts shall be furnished without charge except for labor and transportation.

This Warranty excludes assembled products not manufactured by Gentner Engineering Company, whether or not they are incorporated in a Gentner Engineering Company product or sold under a Gentner Engineering Company part or model number.

THIS WARRANTY IS VOID IF:

A. The equipment has been damaged by negligence, accident or mishandling, or has not been operated in accordance with the procedures described in the operating instructions; or,

B. The equipment has been altered or repaired by other than Gentner Engineering Company personnel or an authorized service representative of Gentner Engineering Company; or,

C. Adaptations or accessories other than those manufactured or provided by Gentner Engineering Company have been made or attached to the equipment which, in the determination of Gentner Engineering Company, shall have affected the performance, safety, or reliability of the equipment; or,

D. The equipment's original serial number has been modified or removed.

Gentner Electronics Corporation does not assume any responsibility for consequential damages, expenses or loss of revenue or property, inconvenience or interruption in operation experienced by the customer due to a malfunction in the purchased equipment. No warranty service performed on any product shall extend the applicable warranty period.

In case of unsatisfactory operation, the purchaser shall promptly notify Gentner Electronics Corporation at the address set forth below, in writing, giving full particulars as to the defects or unsatisfactory operation. Upon receipt of such notice, Gentner Electronics Corporation will give instructions respecting the shipment of the equipment, or such manners as it elects to honor this warranty as above provided. The warranty does not cover damage to the equipment during shipping, and Gentner Electronics Corporation assumes no responsibility for such damage. ALL SHIPPING COSTS SHALL BE PAID BY THE CUSTOMER.

THIS WARRANTY EXTENDS ONLY TO THE ORIGINAL PURCHASER AND IS NOT ASSIGNABLE OR TRANSFERABLE.

Gentner Electronics Corporation
P.O. Box 27647
Salt Lake City, Utah 84127-0647
(801) 975-7200

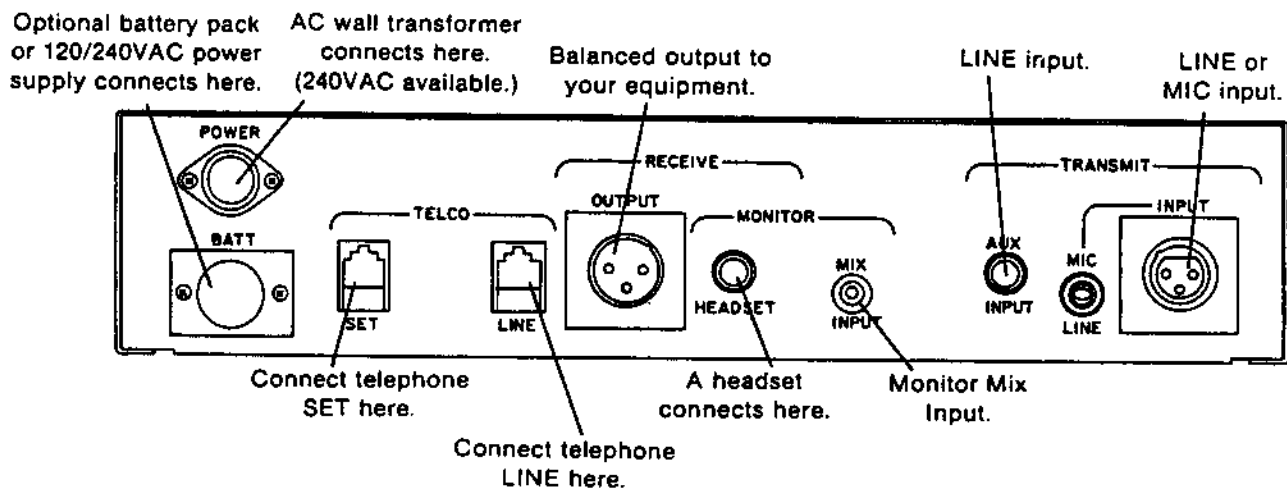
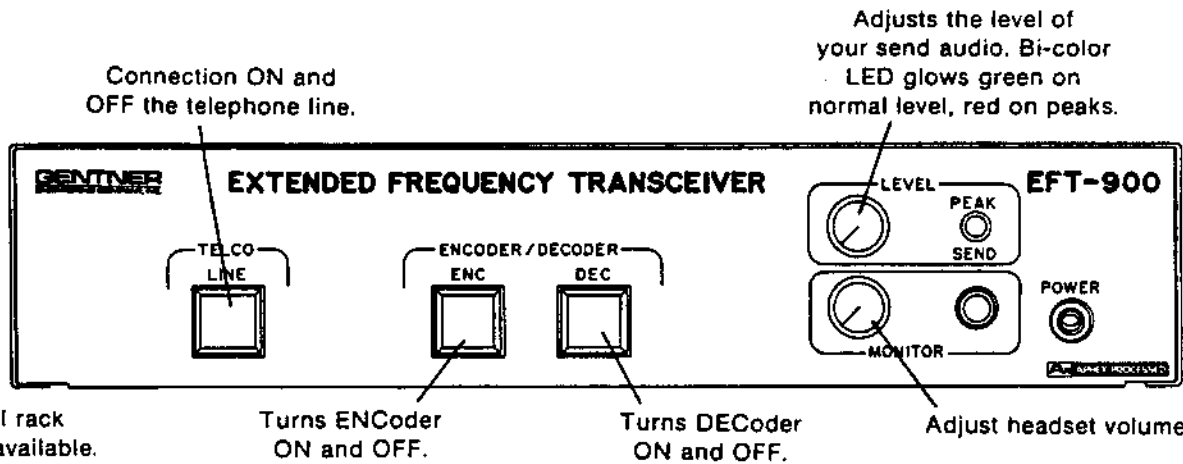

How to Operate the EFT-900

1. Installation. (A more detailed description is provided on page 9.) Connect your microphone or line level audio source to the INPUT or AUX INPUT jacks and place the MIC/LINE switch in the appropriate position. (The AUX INPUT jack is LINE level only.) Plug your headset into either the rear or front panel HEADSET jack and/or connect other monitoring equipment to the OUTPUT XLR jack. These outputs contain caller or "receive" audio. If you desire to monitor other audio in addition to EFT-900 receive audio, make connection via the MIX INPUT mini plug. Now connect the telephone line and telephone set to the standard modular jacks so designated (the red and green wires are the phone line and the yellow/black wires are A-lead; the EFT-900 will provide a closure on the yellow/black wires when the device goes off-hook). Now connect the wall transformer, optional power supply or optional battery pack to the designated connectors.

2. Telephone Line Connection. Pick up the attendant telephone set and dial the desired number. If you're calling an EFT-1000, you'll need to manually 'handshake' the device (refer to EFT-1000 operations manual). Once you have made the desired connection, depress the TELCO LINE button. This takes the set off line and places EFT-900 on line.

3. Send Level. You'll now be communicating with a microphone and headset. Adjust the front panel SEND LEVEL control so that the bi-color LED glows green on normal speech and red on peaks. You'll need to play with this adjustment until it "feels" about right. Sometimes you'll need a lot of red peaks and other times none. The best indicator is your ear...adjust it until it sounds right.

4. Monitor Level. Adjust the front panel MONITOR control so you have a comfortable listening level. This control does not adjust the level to the XLR OUTPUT jack.

5. Encoder/Decoder Switches. If you're not going to use EFT-900 as a frequency extender, leave the ENCODER/DECODER switches in the off position. If you'll be communicating with another EFT-900, an EFT-1000, or a Comrex(r) product push the ENCODER/DECODER switches to the ON position.

When you depress the ENCODE switch, your input audio is shifted up by 250 Hz and then it is sent down the telephone line. When you depress the DECODE switch, the receive audio from the telephone line is shifted down 250 Hz. Since this "shifting" process is done at both ends, you'll never even know that you've been encoded, except that audio quality will be dramatically improved. (See next section for more information.)

Functional Description

EFT-900 System Block Diagram:

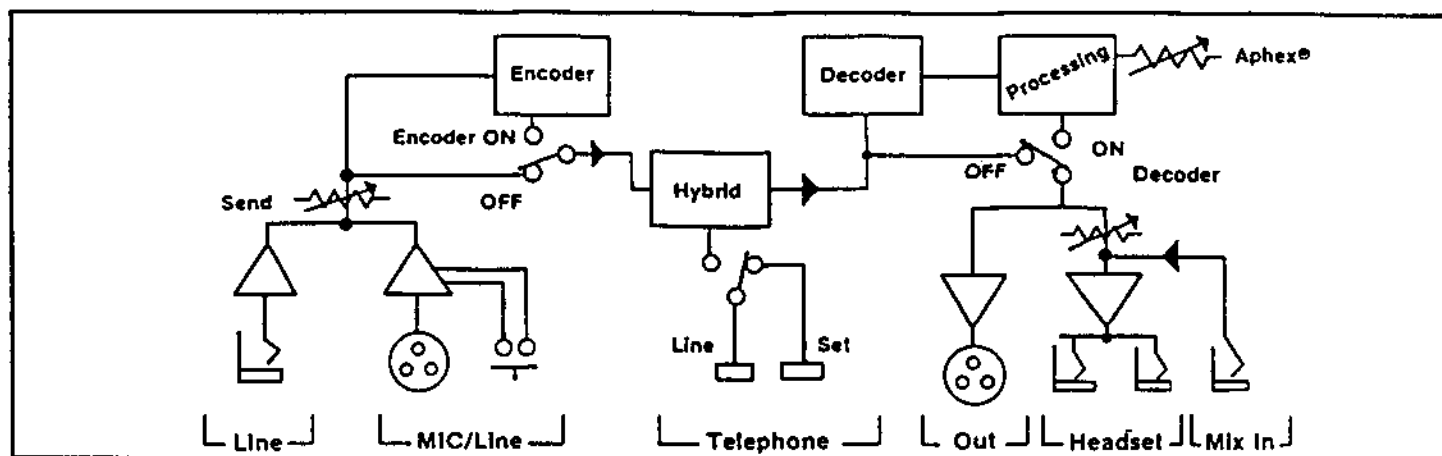

1. What is Frequency Extension? The Extended Frequency Transceiver family of products use a very simple yet sophisticated method to dramatically improve telephone audio quality. The switched telephone network provides a standard bandpass from 300 hz to 3300 hz. Unfortunately, this pass band robs about 2 1/2 octaves of audio content below 300 hz. This audio is especially important to the male voice and its elimination from the program content is very detrimental to the program's perceived audio quality. The process of frequency extension recovers the lost audio from 50hz to 300hz by simply shifting all audio up by 250 hz, sending it down the telephone line, and then shifting it back down 250 hz. For example then, 50 hz becomes 300 hz which can be passed by the telephone line. We do of course loose 250 hz on the upper end of the pass band. But, at 3300 hz this audio only contains 1/7 of an octave and is not as important to the perceived audio quality.

2. How EFT-900 Works. (Refer to block diagram.) Aux input and mic/line level input audio is mixed and sent to the "SEND LEVEL" control. This control adjusts the amount of audio sent down the phone line. There is a front panel bi-color LED that provides a relative level indication glowing green on normal level and red on peaks. Audio is sent both to the "ENCODER" switch and to the input of the encoder that shifts all frequencies up by 250 hz. Depending on the position of the "ENCODER" switch, either non-encoded or encoded audio is sent to the transmit port of the hybrid coupler.

The hybrid coupler makes direct connection to the telephone line via the front panel "TELCO LINE" switch. This switch connects the telephone line either to the "SET" jack or to the hybrid coupler. Note that an A-lead closure is provided on the yellow/black pair for 1A2 and digital type multi-line telephone systems. The hybrid coupler also provides the function of separating send and receive audio.

Receive audio is sent both to the "DECODER" switch and to the input of the decoder/processor that shifts audio down 250 Hz and restores some high audio frequencies. Depending on the position of the "DECODER" switch, either non-decoded or decoded audio is sent to the input of output amplifiers.

This audio is balanced and sent to the rear panel XLR and is mixed with the rear panel "MIX INPUT" audio before being level controlled by the front panel "MONITOR" control. Headset jacks are provided both on the front and rear panels.

3. The Importance of the Transceiver Concept. Although the telephone line is by no means the perfect communication path, it does provide the most widely used and standardized two-way communication path available. Other frequency extension systems provide a one-way path; i.e. a transmitter on one end of the phone line and a receiver on the other end. The Extended Frequency Transceiver (EFT) family of products provide a complete duplex two-way communication path. This allows you to use the telephone as it was intended; i.e. sending high quality audio with directions on the same phone line.

4. Quality Improvement. In the encode/decode position, EFT-900 improves the perceived audio quality four ways:

1. Restoration of the low frequencies (frequency extension).
2. Improved low-end passband signal-to-noise ratio by recovering 2 1/2 octaves of high content band width and by providing a 'brick wall' high pass filter at 249 Hz.
3. Improved high end signal-to-noise ratio by providing sharp low pass filters.
4. Use of Aphex(r) processing to artificially reconstruct high end frequencies by injecting even order harmonics of lower frequencies.

Installation and Options

To install the EFT-900, do the following:

1. Mount the device in a convenient location. An optional rack mount kit is available.
2. Plug the wall transformer into EFT-900 using the connector so designated.
3. Plug the wall transformer into 120VAC. (A 240VAC transformer is available, if needed.)
4. Connect to the telephone line via the rear panel modular jack marked TELCO LINE. The red/green pair is tip and ring while the yellow/black pair is A-lead. EFT-900 will provide a closure on the yellow/black pair when the TELCO LINE switch is depressed. The A-lead closure is provide for connection to 1A2 and digital telephone systems.
5. Now connect a standard telephone set to the jack marked TELCO SET.
6. Install send or transmit audio to either or both of the jacks marked INPUT. The XLR has the following pinouts:

Pin 1	Common
Pin 2	Balanced Audio - 600 ohms
Pin 3	Balanced Audio + 600 ohms

When the MIC/LINE switch is pushed in, EFT-900 will accept a microphone input level of approximately -55 dBm. In the out position, it will look for about a 0dBm input level.

The AUX INPUT jack is unbalanced with the following pinouts:

Tip	Unbalanced Audio	10K ohms
Ring	Same as Tip	
Sleeve	Common	

The AUX INPUT jack is line level only.

7. Adjust the SEND LEVEL control on the front panel for proper level.
8. Now connect output audio either from the jack marked OUTPUT or from the HEADSET jack. The output jack provides 0dBm caller level, balanced, with the same pin outs as the input connector. The headset jack provides high level output audio adjusted by the front panel MONITOR knob. The pinout configuration of these connectors is:

Tip	Headset Audio
Ring	Headset Audio
Sleeve	Common

9. If you desire to monitor any other audio sources, connect the source to the mini jack marked MIX INPUT. This audio will simply be mixed with the normal monitor audio. It will not affect the XLR OUTPUT audio.

10. The device is now ready for operation.

Optional Equipment Available from Gentner

1. 3 1/2" Rack Mounting Kit. Order Model #EFT-RACK.
2. 240VAC Wall Transformer. Order Model #EFT-240VAC.
3. Dual AC Supply (120VAC/240VAC). For use when changing voltage occurs frequently. Order Model #EFT-120VAC/240VAC.

Applications

The EFT-900 is one of the most versatile telephone interfaces you can purchase. The following are a few of the unit's many applications:

1. Remote Broadcasts. The EFT-900 is perfect for local and long distance remotes when you desire to achieve fast, quality remotes with a minimum of set-up time. Since the product has a built-in mic preamp and headset amp, your remote talent won't need to be bothered with any other equipment than the EFT-900 and his mic/headset. Operation is simple too. Since your talent will be receiving cues back from the station via his headset, you won't even need to worry about an off-air monitor. The ease of use and quality improvement will allow you to do more remotes and generate even more sales for your station.

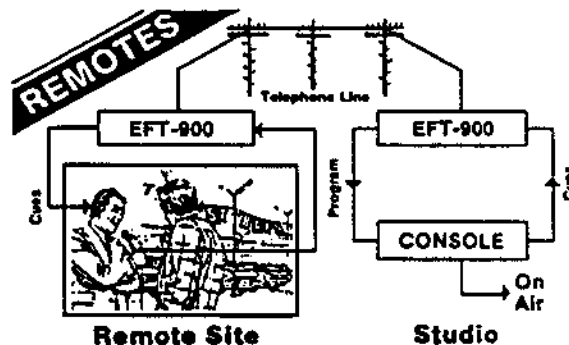

2. Sports. The EFT-900 is perfect for your sports remotes! No longer will you have worry timing spots...now your sportscaster will hear them on his headset...and if the line is dropped, he'll hear it immediately. The quality improvement will reduce listener fatigue and increase your audience share. Since EFT-900 is so easy to set up and operate, your sportscaster will be free to concentrate on the game.

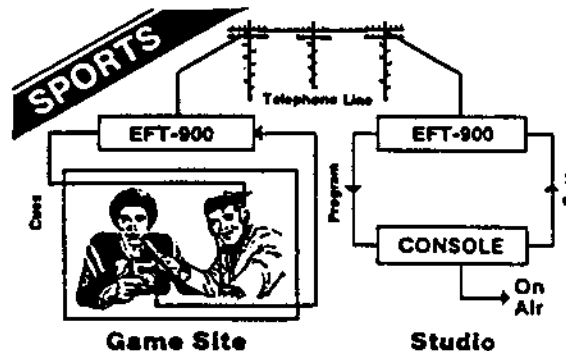

3. News. Whether it's a late breaking story or feeding actualities from one location to another, EFT-900 is the fast, hassle-free solution. Since your newsmen will be receiving return cues via his headset, you'll be able to conduct interviews and exchanges from the studio. The quality improvement will give your station the competitive edge.

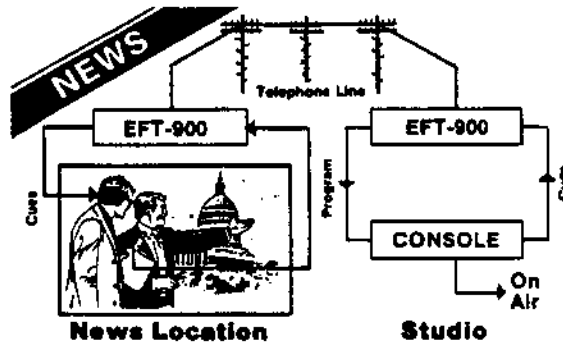

4. Call-ins. In addition to the above normal frequency extended applications, EFT-900 can also be used for call-ins. Since the product incorporates a preset internal hybrid your callers will be able to hear all the console audio for conducting normal conversations.

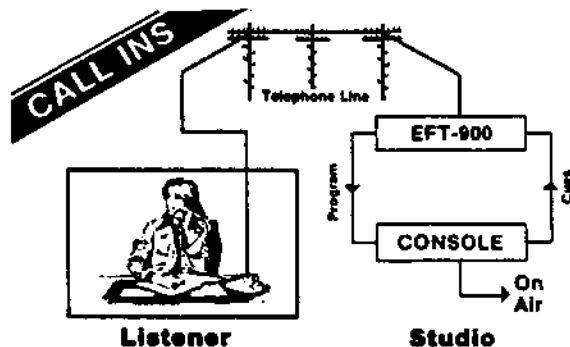

Application Notes.

The following diagrams show how to set up EFT-900 for the applications previously discussed.

1. Standard Remote Set-up. At the studio end, EFT-900 is connected directly to the telephone line. The output of the device is connected via the rear panel XLR to the input of your console. The return audio (the audio to be fed to the remote) is fed via the mic/line or aux input jack on the rear panel. This audio should not contain any of the remote site's audio (mix-minus refers to all of the audio on your console MINUS the remote audio). This permits the person at the remote site to hear all of the on-air audio so that he knows exactly what's going on. In addition, this will allow the studio talent to converse on-air with the remote site.

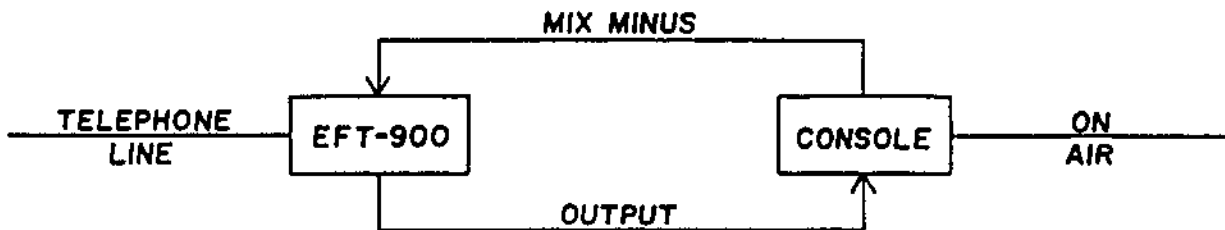

2. Off Air Cueing. Before each remote broadcast, you'll need to efficiently set up the remote. The following diagram shows how a PTT mic button is used to talk to the remote site. In this application, the console operator would listen on his cue bus and talk into the control room microphone.

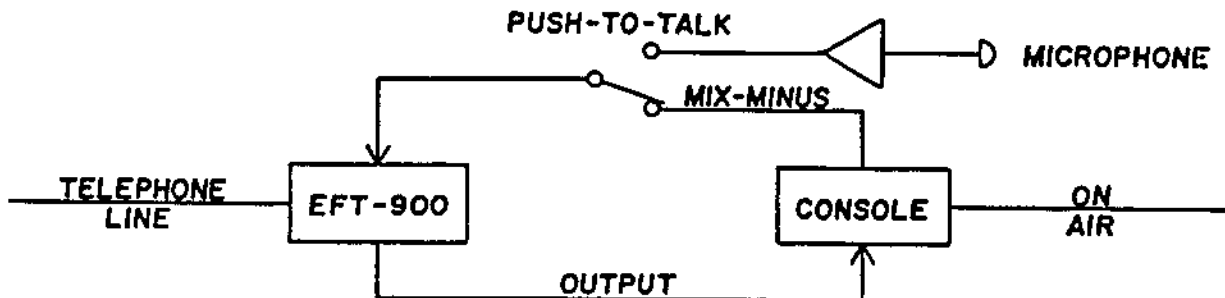

3. Cueing During the Broadcast. Normally you aren't able to cue the remote while they are on the air. This is because the cue audio is not totally rejected by the internal hybrid of the EFT-900 and therefore goes on air. For this reason, you must mute the receive audio during the cue period. If the cue is short, the short interruption in the program is hardly noticed by the

audience. The following diagram shows how this is accomplished. We recommend this circuit for all cueing applications because it eliminates the possibility of acoustic feedback when listening through the cue speaker.

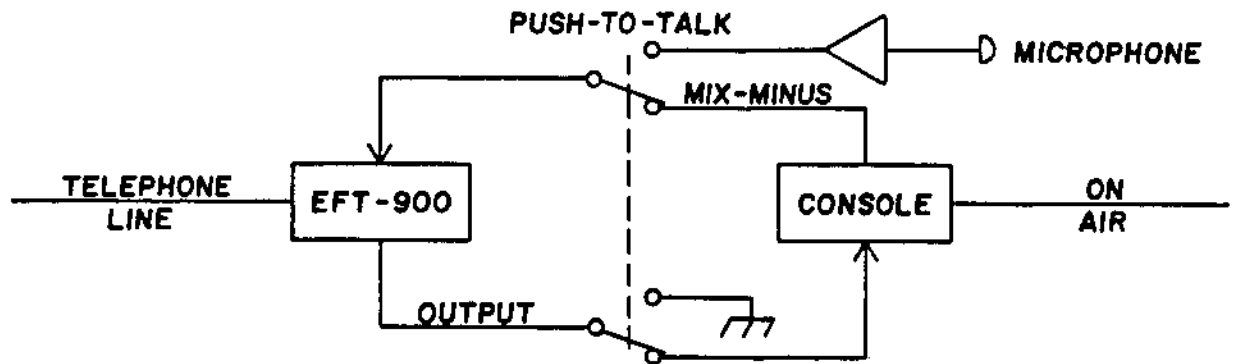

4. Using EFT-900 as a Telco Interface. When used with the ENCODE and DECODE switches in the OFF position, the EFT-900 can be used as standard telephone interface. You won't need to change your set-up either. The following diagram shows the basic set-up:

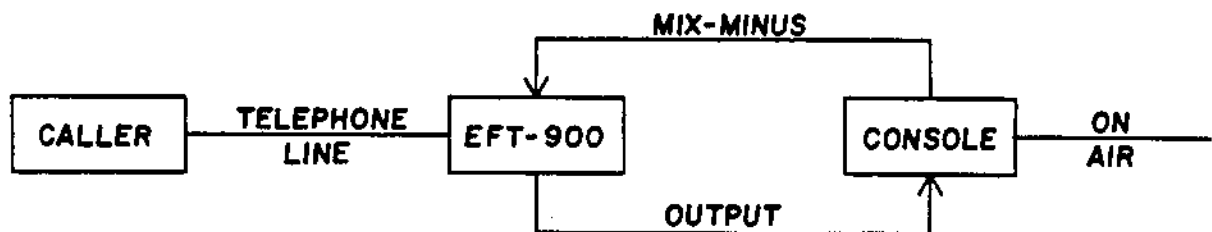

5. Using EFT-900 with TELEPROCESSOR. The EFT-900 significantly improves your telephone line quality. However, to maximize the sound of your phone line you can use the unit in conjunction with Gentner's TELEPROCESSOR, which adds equalization adjustments to your receive audio and maintains a consistent send level to your remote site. In addition, the TELEPROCESSOR has a built-in cue switch with condenser mic; this eliminates the need to build a separate cue circuit.

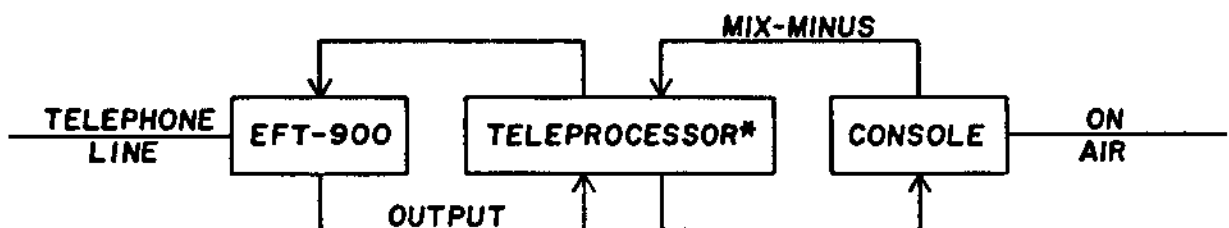

* HAS BUILT-IN MOMENTARY CUE SWITCH AND CONDENSOR MIC

Quick Reference

XLRs

Pin #	1	Common
	2	Audio (low)
	3	Audio (high)

Monitor Jacks

Pin #	Sleeve	Common
	Tip	Left Headset
	Ring	Right Headset

Telephone Jacks (USOC RJ-11C)

Color	Red	Tip
	Green	Ring
	Yellow	A-lead
	Black	A Common

(EFT-900 provides a closure on the yellow/black pair for 1A2 and other telephone systems.)

Remote Site Set-up.

1. Telephone Line to LINE modular jack.
2. Telephone Set to SET modular jack.
3. Microphone to Mic/Line XLR (depress Mic/Line button).
4. Headset to MONITOR jack (front and/or rear panels).
5. Plug wall transformer into rear POWER jack.
6. Connect wall transformer to power.

Remote Site Operation.

1. Adjust SEND LEVEL to approximately 12 O'Clock.
2. In the ENCODE mode, adjust level for GREEN LED flashes with occasional RED flashes.
3. Adjust MONITOR LEVEL for proper headset level.

WARRANTY

GENTNER COMMUNICATIONS CORPORATION (Manufacturer) warrants that this product is free of defects in both materials and workmanship. Should any part of this equipment be defective, Manufacturer agrees, at its option, to:

A. Repair or replace any defective part free of charge (except transportation charges) for a period of one year from the date of the original purchase, provided the owner returns the equipment to the Manufacturer at the address set forth below. No charge will be made for parts or labor during this period;

B. Furnish replacement for any defective parts in the equipment for a period of one year from the date of original purchase. Replacement parts shall be furnished without charge, except labor and transportation.

This Warranty excludes assembled products not manufactured by Manufacturer whether or not they are incorporated in a Manufacturer product or sold under a Manufacturer part or model number.

THIS WARRANTY IS VOID IF:

A. The equipment has been damaged by negligence, accident, act-of-God or mishandling, or has not been operated in accordance with the procedures described in the operating and technical instructions; or,

B. The equipment has been altered or repaired by other than Manufacturer or an authorized service representative of Manufacturer; or,

C. Adaptations or accessories other than those manufactured or provided by Manufacturer have been made or attached to the equipment which, in the determination of Manufacturer, shall have affected the performance, safety or reliability of the equipment; or,

D. The equipment's original serial number has been modified or removed.

NO OTHER WARRANTY, EXPRESS OR IMPLIED, INCLUDING WARRANTY OF MERCHANTABILITY OR FITNESS FOR ANY PARTICULAR USE, APPLIES TO THE EQUIPMENT, nor is any person or company authorized to assume any warranty for Manufacturer or any other liability in connection with the sale of Manufacturer's products.

Manufacturer does not assume any responsibility for consequential damages, expenses or loss of revenue or property, inconvenience or interruption in operation experienced by the customer due to a malfunction in the purchased equipment. No warranty service performed on any product shall extend the applicable warranty period.

In case of unsatisfactory operation, the purchaser shall promptly notify Manufacturer at the address set forth below in writing, giving full particulars as to the defects or unsatisfactory operation, upon receipt of such notice, Manufacturer will give instructions respecting the shipment of the equipment, or such other matters as it elects to honor this warranty as above provided. This warranty does not cover damage to the equipment during shipping and Manufacturer assumes no responsibility for such damage. All shipping costs shall be paid by customer.

This warranty extends only to the original purchaser and is not assignable or transferable.

Gentner

GENTNER COMMUNICATIONS CORPORATION

1825 West Research Way
Salt Lake City, Utah 84119
Telephone: (801) 975-7200
Facsimile: (801) 977-0087