DIGITAL HYBRID™

USER'S MANUAL

GENTNER™
ENGINEERING COMPANY, INC.

540 West 3560 South
Salt Lake City, Utah 84115
(801) 268-1117
TWX: 910-380-6909 (GENTNER UD)

DIGITAL HYBRID USER'S MANUAL

TABLE OF CONTENTS

SECTION ONE	SUMMARY	
1.1	Introduction.....	1-1
1.2	General Description.....	1-1
1.3	Product Specifications.....	1-3
1.4	Warranty Information.....	1-5
SECTION TWO	PRODUCT DESCRIPTION	
2.1	Digital Hybrid Front and Rear Panels.....	2-1
2.2	Front Panel Controls and Indicators.....	2-2
2.3	Rear Panel Controls and Connections.....	2-5
SECTION THREE	INSTALLATION	
3.1	Initial Inspection.....	3-1
3.2	AC line Voltage Configuration.....	3-1
3.3	Direct Connection to Single C.O. line.....	3-2
3.4	Connection to a 1A2 Key Service Unit.....	3-3
3.5	Connection to Digital Key Service Telephones..	3-6
3.6	Connection to Audio Equipment.....	3-8
3.7	Adjustment of Front Panel Trimmers.....	3-10
3.8	User Option Switches.....	3-12
3.9	Remote Control of Digital Hybrid Functions....	3-13
3.10	Multiple Unit Conferencing.....	3-16
SECTION FOUR	OPERATION	
4.1	Basic Operation.....	4-1
4.2	Typical Broadcast Application.....	4-1
4.3	Teleconferencing Use.....	4-2
4.4	Auditorium or Meeting Use.....	4-3
SECTION FIVE	TECHNICAL DESCRIPTION	
5.1	Send Audio Circuit.....	5-1
5.2	Telephone Line Circuitry.....	5-3
5.3	Caller (Receive) Audio Circuitry.....	5-4
SECTION SIX	GENTNER ENGINEERING CUSTOMER SERVICE	
6.1	Gentner Customer Service.....	6-1
6.2	Warranty Repair Procedures.....	6-1

SECTION ONE

SUMMARY

1.1 Introduction

The purpose of this manual is to provide the necessary installation and operational information needed for use of the Gentner Digital Hybrid telephone system. We feel that the overall performance of the system will be enhanced if the purchaser will take the time to read this brief but complete manual.

1.2 General Description

The Digital Hybrid is a state-of-the-art telephone interface that lends itself to both broadcast and teleconferencing applications. It incorporates digital signal processing to achieve the best overall hybrid performance available with current technology.

Microprocessor technology provides an easy method for studio engineers and talent to place clean telephone caller audio "on the air;" the unit can equally provide feedback-free, high-quality audio in a teleconference setting. The Digital Hybrid incorporates the following features:

A. Digital Signal Processing technology yields the lowest possible hybrid leakage, preventing feedback and discoloration of studio microphone audio.

B. Carefully designed bandpass filters on both the send and receive ports mask unwanted hum, Central Office switching noise and telephone multiplex distortion.

C. Audio processors on both send and receive ports keep the send audio and caller audio at consistent levels.

D. Caller Control circuitry momentarily reduces caller audio by an adjustable amount to allow for a smooth interchange between the announcer and the caller.

E. Microprocessor circuitry provides for auto-answer, auto-disconnect and automatic muting of caller audio.

F. Microcontroller code, DSP nulling algorithm, and complete system timing functions are contained in EPROMs, allowing for future updates of the Digital Hybrid as technology advances. This also allows for custom applications.

1.3 Product Specifications

Telephone Interconnect-

Line connection	Modular RJ-11C and DC-37P
External set	RJ-11C and DC-37P (line looped through to SET when unit is off)
Common mode voltage protection	Intentional path to ground at ± 230 V on tip or ring
Automatic answer	Selectable after 1 complete ring (45 to 130 Vrms, 15 to 90 Hz)
Automatic disconnect	Optional on loop discontinuity (loop reversal or loop drop)
Hybrid	Standard hybrid transformer with DSP leakage suppression
Key Service Compatibility	Any key system providing tip and ring to telephone instruments
Tip/Ring switching	Omron 4-pole bifurcated contact relay

Audio Interface-

Main input	All audio available on rear panel DC-37P connector
Auxiliary input	Active balanced bridging, 0dBm line level or -55dBm mic level (user selectable) Adjustable, XLR
Caller Output	0dBm line level only Non-adjustable, XLR'
Mix Output	600 Ohm active balanced XLR; +20dBm clip level into 600 Ohm load.
	600 Ohm active balanced XLR; +20 dBm clip level into 600 Ohm load.

Output gain	Unity gain, main input to mix output at line level
Frequency response	Main input to Mix output: ± 1 dB, 10Hz to 100kHz
Distortion	Main input to Mix output: .005%
SNR	>100dB below clip level
Telephone transmission-	All measurements are referenced to a -15dBm send level.
Send distortion	<.3%
Send SNR	>55dB
Send filter	± 1 dB, 350 to 2550Hz ± 30 dB, 190 to 3100Hz
Telephone receive-	All measurements referenced to a -15dBm caller level.
Receive distortion	<.4%
Receive SNR	>50dB
Receive filter	± 1 dB, 250 to 3000Hz ± 30 dB, 135 to 4200Hz
Hybrid performance-	>24dB return loss on typical line using wide band white noise, adjusted for -20dBm send level, caller circuit adjusted for 20dB gain.
Audio processors-	
Send processor:	(user selectable)
maximum shelved gain	15dB
maximum gain reduction	20dB
gate threshold	-26dBm
Receive processor:	(user selectable)
maximum shelved gain	10dB
maximum gain reduction	20dB
gate threshold	-32dBm caller level

Power- 117/234 VAC, 50/60 Hz
15 Watts maximum

Temperature range- 0 to 50 degrees C operational

Physical size- unit requires one standard rack
space (1.75" x 19" x 12")

Weight- 10 Lbs. (unit)
13 Lbs. (shipping)

Remote Control- Rear panel DC-37P
Momentary or sustained control
for ON/OFF (user selectable)
All audio and telephone connections
are available on connector.

Caller Control- Internally or externally
adjustable; 0 to 40dB linear.
May be disabled if desired.

User Options- Line or Mic level, SEND input
Auto-answer after 1 complete ring
Auto-disconnect on loop drop
Re-null/mute on loop drop
Momentary/sustained control
Send processor enable/disable
Receive processor enable/disable
Port conference enable/disable

1.4 Warranty Information

Gentner Engineering Company warrants that this product is free from defects in both materials and workmanship. Should any part of this equipment be defective, Gentner Engineering Company agrees, at its option, to:

A. Repair or replace any defective part free of charge (except transportation charges) for a period of one year from the date of the original purchase, provided the owner returns the equipment to Gentner Engineering Company at the address set forth below. No charge will be assessed for parts or labor during this period.

B. Replace or furnish replacement for any defective parts in the equipment for a period of one year from the date of the original purchase. Replacement parts shall be furnished without charge except for labor and transportation.

This warranty excludes assembled products not manufactured by Gentner Engineering Company, whether or not they are incorporated in a Gentner Engineering Company product or sold under a Gentner Engineering Company part or model number.

THIS WARRANTY IS VOID IF:

A. The equipment has been damaged by negligence, accident or mishandling, or has not been operated in accordance with the procedures described in the operating instructions; or,

B. The equipment has been altered or repaired by other than Gentner Engineering Company personnel or an authorized service representative of Gentner Engineering Company; or,

C. Adaptations or accessories other than those manufactured or provided by Gentner Engineering Company have been made or attached to the equipment which, in the determination of Gentner Engineering Company, shall have affected the performance, safety or reliability of the equipment; or,

D. The equipment's original serial number has been modified or removed.

NO OTHER WARRANTY, EXPRESS OR IMPLIED, INCLUDING WARRANTY OF MERCHANTABILITY OR FITNESS FOR ANY PARTICULAR USE, APPLIES TO THE EQUIPMENT, nor is any person or company authorized to assume any warranty for Gentner Engineering Company or any other liability in connection with the sale of Gentner products.

Gentner Engineering Company does not assume any responsibility for consequential damages, expenses or loss of revenue or property, inconvenience or interruption in operation experienced by the customer due to a malfunction in the purchased equipment. No warranty service performed on any product shall extend the applicable warranty period.

In case of unsatisfactory operation, the purchaser shall promptly notify Gentner Engineering Company at the address set forth below, in writing, giving full particulars as to the defects or unsatisfactory operation. Upon receipt of such notice, Gentner Engineering Company will give instructions respecting the shipment of the equipment, or such manners as it elects to honor this warranty as above provided. The warranty does not cover damage to the equipment during shipping and Gentner Engineering Company assumes no responsibility for such damage. ALL SHIPPING COSTS SHALL BE PAID BY THE CUSTOMER.

THIS WARRANTY EXTENDS ONLY TO THE ORIGINAL PURCHASER AND IS NOT ASSIGNABLE OR TRANSFERABLE.

Gentner Engineering Company, Inc.
540 West 3560 South
Salt Lake City, Utah 84115
(801) 268-1117

Digital Hybrid User's Manual Section Two: Product Description

SECTION TWO

DETAILED PRODUCT DESCRIPTION

2.1 Digital Hybrid Front and Rear Panels

Please reference this diagram as needed while reading the discussion that follows.

Front panel dip switch assignments

(Numbered left to right)

1. Auto-answer enable
2. Auto-disconnect enable
3. Re-nulling enable
4. Momentary control enable
5. Send AGC enable
6. Caller AGC enable
7. Caller control enable
8. Port conference enable
9. Spare
10. Spare

FRONT VIEW

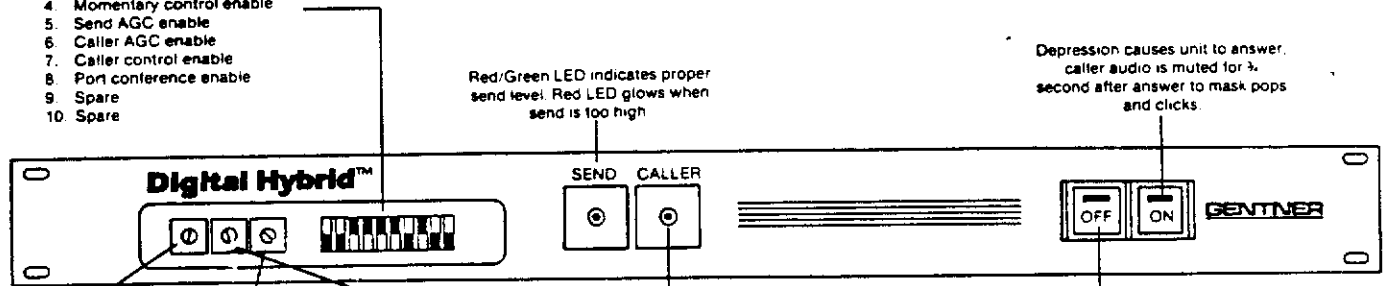

Red/Green LED indicates proper send level. Red LED glows when send is too high

Depression causes unit to answer. caller audio is muted for 3/4 second after answer to mask pops and clicks.

SEND

Set-up adjustment made at time of installation. Adjusted until "Send" LED glows green and occasionally red on peaks.

CALLER CONTROL

When remote caller control is not used, the control adjusts the amount of caller reduction when send audio is present

Green LED indicates the presence of caller audio.

Depression causes unit to hang-up after caller audio has been muted.

CALLER
Adjust level to match input level to your audio equipment

REAR VIEW

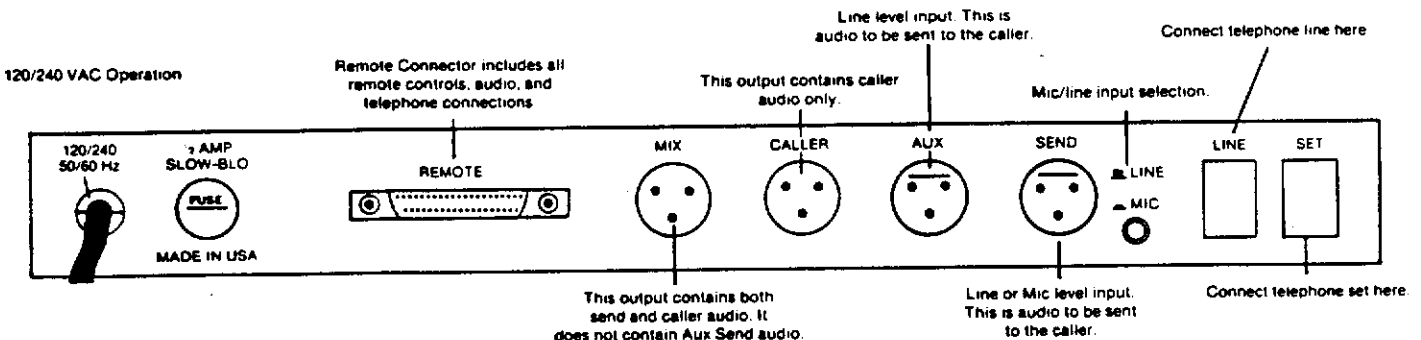

120/240 VAC Operation

Remote Connector includes all remote controls, audio, and telephone connections

This output contains caller audio only.

Line level input. This is audio to be sent to the caller.

Connect telephone line here

Mic/line input selection.

This output contains both send and caller audio. It does not contain Aux Send audio.

Line or Mic level input. This is audio to be sent to the caller.

Connect telephone set here.

Digital Hybrid User's Manual Section Two: Product Description

2.2 Front Panel Controls and Indicators

The front panel of the Digital Hybrid contains the following:

ON switch - when the ON button is depressed, the Digital Hybrid closes its line relay, connecting the hybrid circuitry to the telephone line. At this time, the green LED in the ON switch will illuminate, indicating an on-line status. The internal microprocessor mutes caller audio, waits for the telephone loop current to become stable and then applies a 300 millisecond burst of white noise to the telephone line. This noise enables the Digital Signal Processor (DSP) to adjust its filter coefficients to maximize the hybrid null. 100 milliseconds after the noise has been removed, the microprocessor removes the mute from the caller amplifier, allowing telephone line audio to appear at the Caller XLR connector on the rear panel.

If, at any time, the ON button is redepressed during the course of a call, the DSP is reinitialized and the nulling/muting process repeats itself without dropping the existing caller.

A more detailed description of the nulling process may be found in section 5 of this manual.

OFF switch - when the OFF button is depressed, the Digital Hybrid disconnects from the telephone line and illuminates the red LED in the OFF button. If the OFF button is additionally depressed and held, the unit will go into the send level setup mode. (See descriptions of Send pot and trimmer for further details.)

SEND LED (WITH OFF BUTTON DEPRESSED) - when the hybrid is in the off mode, if the OFF button is depressed and held, the SEND LED will indicate the magnitude of the send audio. The SEND LED is a bi-color (red/green) LED, with green indicating a send level within the adjustment range of the send processor and telephone line limiter. The red condition indicates peaks 10dB above the nominal send level.

SEND LED (IN "ON" CONDITION) - When the hybrid is on line, the SEND LED glows green, indicating the presence of send audio. The same logic that drives this green LED also drives the Caller Control circuit, which can be used to dim the caller whenever send audio is present.

CALLER LED - when the Digital Hybrid is on line, the CALLER LED glows green, indicating the presence of caller audio. The same logic that drives this LED is also fed to the DSP to stop

Digital Hybrid User's Manual Section Two: Product Description

the nulling process whenever the caller speaks and to operate the gate threshold of the receive processor.

REMOVABLE FRONT PANEL - this panel conceals three user adjustable trimmer potentiometers and ten option switches. To facilitate quick adjustment, the functions of these controls are detailed on the reverse side of this removable panel. Each control is detailed below.

SEND LEVEL TRIMMER - this trimmer is used to adjust the send audio to the Digital Hybrid circuitry. With audio applied to the SEND XLR, the user should depress the front panel OFF button and adjust this pot clockwise until occasional peaks are observed on the SEND LED.

CALLER CONTROL TRIMMER - with this control rotated fully counterclockwise, the Digital Hybrid's send and receive audio operate full duplex (there is no reduction of caller audio). As the Caller Control trimmer is rotated clockwise, the caller audio is dimmed in amplitude whenever send audio is present. The amount of dimming is determined by the amount of rotation on this trimmer. A full clockwise position dims the caller approximately 40dB. This trimmer is linear in its operation, i.e. half rotation equals 20dB of dimming. This function can be removed via the rear panel "remote" connector, using an external 1K linear taper pot. When the remote pot is physically connected, internal circuitry renders the front panel Caller Control trimmer inoperative. Operation of either of these pots is enabled via option switch #7, as described below.

CALLER LEVEL TRIMMER - this trimmer potentiometer adjusts the caller's amplitude at the CALLER and MIX rear panel XLRs. This pot should be set to provide an adequate level to the audio equipment used.

USER OPTION SWITCHES - these switches are numbered 1 through 10, left to right, as viewed from the front.

#1: Auto Answer enable. With this switch in the UP position, the Digital Hybrid will automatically answer a telephone line when the appropriate ringing voltage is present. To obtain the best possible hybrid null, the microprocessor waits for one complete ring before answering the line. When the unit answers the line, it automatically goes through the same nulling procedure as if the front panel ON switch had been depressed.

#2: Auto Disconnect enable. With this switch in the UP position, the unit will automatically disconnect from the telephone line when telephone line loop current is either removed or reversed. Most central offices provide this as an indication

Digital Hybrid User's Manual Section Two: Product Description

that the calling party has hung up. When loop current is dropped, the microprocessor immediately mutes caller audio to prevent the loud "pop" of the DC interruption from reaching the audio equipment.

#3: Re-null and mute enable. With this switch in the UP position, the Digital Hybrid will automatically go through the nulling/muting process every time telephone loop current is dropped and then re-established. When the line is dropped the Digital Hybrid will mute caller audio. When the line returns, it will renull and unmute caller audio. This allows the unit to be used with very simple call directors such as those found on a multi-line 1A2 telephone instrument. The microprocessor will automatically provide the muting function necessary for a smooth, "popless" transition from line to line. When switch #3 is in the UP position, the operation of switch #2 (auto disconnect) is disabled.

#4: Momentary control enable. This switch is normally used in the UP position so that the Digital Hybrid can be placed on and off line using the front panel ON/OFF momentary switches. The ON/OFF switches are also remoted on the 37 pin connector on the rear panel. The Digital Hybrid may be remotely controlled using either a momentary or sustained closure. If the user's equipment provides a sustained closure output, option switch #4 should be placed in the DOWN position. When this closure is made on the remote connector's ON pin, the hybrid will go through the nulling procedure described previously. When the closure is open, the hybrid will return to the off line state.

#5: Send processor enable. When this switch is in the UP position, the Digital Hybrid's send processor will be operational. The processor can be used to guarantee that a consistent level is sent to the caller. When switch #5 is in the DOWN position, the send amplifier will revert to unity gain. However, a limiter circuit in the send amplifier will ensure that the send audio level never exceeds -12dBm on the telephone line, keeping the unit well within FCC part 68 specifications.

#6: Caller processor enable. With this switch in the UP position, the Digital Hybrid's receive processor will be operational. The processor can be used to guarantee consistent caller audio levels from line to line. When switch #6 is in the DOWN position, the receive amplifier is forced to unity gain.

#7: Caller Control enable. With this switch in the UP position, the Caller Control circuitry is enabled. If switch #7 is in the DOWN position, the front panel Caller Control trimmer and the optional remote Caller Control pot will be disabled.

Digital Hybrid User's Manual Section Two: Product Description

#8: Port conference disable. With this switch in the UP position, the port conferencing function of the Digital Hybrid is disabled. Port conferencing forces the Digital Hybrid into a half-duplex mode. When the caller speaks, and his amplitude is detected on the front panel CALLER LED, send audio is electronically switched off. This function can be very useful in teleconferencing to eliminate conference room acoustic echo from being sent back to the caller. In broadcast uses, switch #8 would normally be set in the UP, or disabled, position.

#9 and #10: Spare. The current version of software does not utilize these switches.

2.3 Rear Panel Controls and Connectors

AC POWER CORD: The function of this connector is obvious; however, it should be noted that the unit is factory set at 117 VAC unless otherwise ordered. The voltage may be changed to 234 VAC if needed. Please refer to section 3.3 for details.

FUSE: The Digital Hybrid utilizes a 0.5 amp, slow-blow fuse.

REMOTE CONNECTOR: Remote control functions, along with all rear panel connectors, appear on the remote connector to allow for single cable interconnection between the Digital Hybrid and customer equipment. Functions are remoted on this connector as follows:

#1 Set Tip (located in upper left corner, viewed from rear)

#20 Set Ring (located beneath pin #1)

These connections are used for route-through of the telephone line. They are the same as the RJ-11C SET connector.

#2 Line Tip

#21 Line Ring

These pins provide connection to the actual telephone line. They are the same as the RJ-11C LINE connector.

#3 A1

#22 A-Common

These are the A-lead closure for 1A2 and other key service

Digital Hybrid User's Manual Section Two: Product Description

units.

#4, #5, #23 Ground

This ground has the same potential as the chassis.

#6 Mix Out +
#24 Mix Out -

This is balanced Mix audio output and is the same as the MIX XLR on the rear panel.

#7 Caller Out +
#25 Caller Out -

This is balanced Caller audio output and is the same as the CALLER XLR.

#8, #26 Analog Ground

This is ground return for balanced audio connections.

#9 AUX SEND +
#27 AUX SEND -

This is balanced auxiliary send audio input and is the same as the rear panel AUX SEND XLR.

#10 SEND +
#28 SEND -

This is balanced send audio input and is the same as the rear panel SEND XLR.

#11 Port Conference +
#29 Port Conference -

Application of a DC voltage from 4 to 25V on these pins, in the polarity indicated, will force the Digital Hybrid into a port conferencing mode.

Digital Hybrid User's Manual Section Two: Product Description

#12 Caller Control

#30 Caller Control return

These connections provide for the remoting of the Caller Control pot. A 1K linear taper pot should be wired so that at full counterclockwise rotation, 0 Ohms is placed across these two connections. When an external pot is connected to these pins, the front panel Caller Control trimmer is automatically disabled.

#13 Send Indicator -

#31 +5V/180 Ohms

These pins are used to remote the SEND indicator LED. Pin 13 provides an open collector output capable of sinking 100mA at up to 40V. If a single remote LED is to be used, connect the cathode to pin 13. Pin 31 provides a convenient +5V source with a 180 Ohm limiting resistor, allowing the LED to operate at approximately 20mA. Tie the LED's anode to pin 31.

#14 Caller Indicator -

#32 +5V/180 Ohms

These pins are used to remote the CALLER indicator LED. Operation is similar to that described above for the SEND indicator.

#15 ON indicator -

#33 +5V/180 Ohms

These pins are used to remote the ON indicator LED.

#16 OFF indicator -

#34 +5V/180 Ohms

These pins are used to remote the OFF indicator LED.

#17 Mute switch

#35 Switch common

Connecting these two pins will cause the Digital Hybrid's caller amplifier to be muted. The logic for this function is optically isolated from the remote pins to provide protection of Digital Hybrid circuitry from possible damage caused by improper voltages.

Digital Hybrid User's Manual Section Two: Product Description

#18 ON switch
#36 Switch common

A closure on these two pins will cause the Digital Hybrid to go on line. This connection need only be a momentary connection if front panel option switch #4 is in the UP position.

#19 OFF switch
#37 Switch common

A momentary closure on these two pins will cause the Digital Hybrid to go off line.

MIX XLR: Balanced audio output available at this connector is the sum of the the audio input at the SEND XLR and the caller audio. This connector does not contain AUX SEND audio.

Pin 1 = Analog ground
Pin 2 = Mix out -
Pin 3 = Mix out +

CALLER XLR: Balanced audio output at this connector contains caller (receive) audio.

Pin 1 = Analog ground
Pin 2 = Caller out -
Pin 3 = Caller out +

AUX SEND XLR: Balanced bridging input. Line level audio applied to this connector will be sent to the caller. This audio, however, does not appear at the MIX output.

Pin 1 = Analog ground
Pin 2 = Aux send -
Pin 3 = Aux send +

SEND XLR: Balanced bridging input. Mic or line level (as selected by adjacent switch) applied to this connector will be sent to the caller. Line level audio into this connector will appear at the MIX output. Mic level audio will be amplified 55dB and applied to the MIX output.

Pin 1 = Analog ground
Pin 2 = Send -
Pin 3 = Send +

Digital Hybrid User's Manual Section Two: Product Description

TELEPHONE LINE CONNECTOR: This modular RJ-11C connector provides direct connection to the telephone line or associated call director.

Pin designations are, right to left:

Pin 1 = N/C
Pin 2 = A1
Pin 3 = Tip
Pin 4 = Ring
Pin 5 = A Common
Pin 6 = N/C

TELEPHONE SET CONNECTOR: This modular RJ-11C connector provides connection for a local single line telephone instrument. When the Digital Hybrid is in the OFF mode, the telephone line is routed to this jack. When the hybrid is in the ON mode, this jack is disabled.

Pin designations are, right to left:

Pin 1 = N/C
Pin 2 = A Common
Pin 3 = Ring
Pin 4 = Tip
Pin 5 = A1
Pin 6 = N/C

***** SPECIAL INSTRUCTIONS FOR *****
***** DIGITAL TELEPHONE INSTALLATIONS *****

When installing the Digital Hybrid on some digital telephone systems, it may be necessary to change an internal jumper. This jumper bypasses the line sensing circuitry within the device and allows non-DC biased audio to flow. Without the jumper in place, the rectifiers would block the pure AC signal. Change this jumper as follows:

1. Remove the top cover by loosening the four retaining screws and lifting the cover straight up.
2. Locate the rear panel modular telephone jacks.
3. Near these connectors you will find two jumpers marked "DC BYPASS".
4. For normal telephone lines with AC and DC on the line, place the jumper in the "A" position.
5. For some digital telephone lines with AC only on the line, place the jumper in the "B" position.

***** IN THE "B" POSITION, THE AUTO ANSWER, AUTO DISCONNECT, AND RENUALL FUNCTIONS WILL NOT OPERATE. *****

Questions?? Call our customer service at (801) 268-1117, they'll be glad to answer any questions you might have.

SECTION THREE

INSTALLATION

3.1 Initial inspection

The shipping container should contain the following:

Digital Hybrid
This manual
Warranty card
A mating connector for the DC-37P rear panel connector
A modular telephone extension cord
Four rack screws with protective washers

If any of these items are missing, contact Gentner Customer Service or the distributor that supplied the product. If any shipping damage is noted, contact the shipping carrier (be sure to save the shipping container for inspection).

3.2 AC line voltage configuration

Unless otherwise noted, this unit has been shipped from the factory configured for 117VAC operation. If the line voltage is 234VAC, proceed with the following instructions:

A. Place the unit on a static-free work surface to avoid damage to the internal CMOS components.

B. Remove the top cover by loosening its four screws.

C. Locate the power transformer and its wiring harness, connected to transformer pins #1-4. Refer to diagram.

D. If the unit is to be operated on 117VAC, connect this harness to the WHITE molex mating connector.

E. If the unit is to be operated on 234VAC, connect this harness to the RED molex mating connector.

F. Replace the top cover and tighten the screws.

Digital Hybrid User's Manual Section Three: Installation

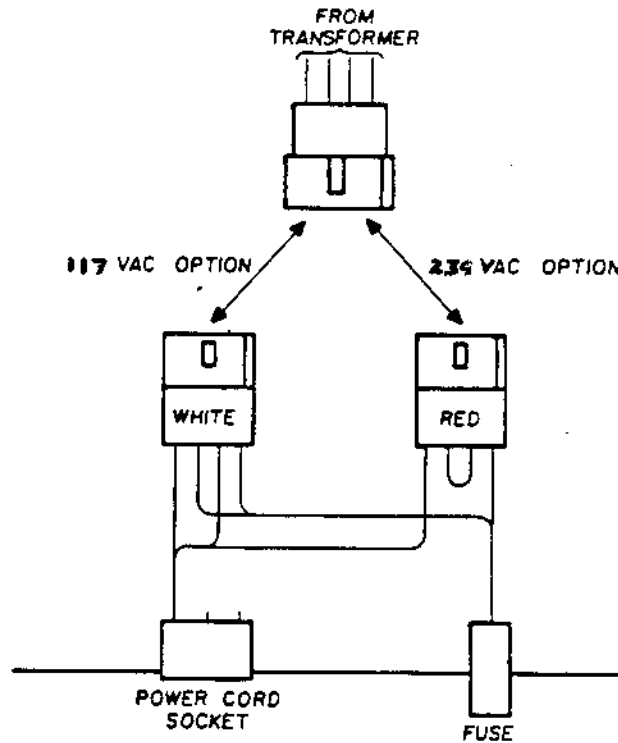

Diagram 1. AC line voltage configuration

3.3 Direct connection to a single central office line

Refer to diagram 2. Connect the incoming telephone line to the Digital Hybrid's LINE jack with the appropriate modular telephone cable. An optional telephone instrument can be connected via the SET jack. Telephone calls can be placed and received normally with the telephone instrument when the Digital Hybrid is off line.

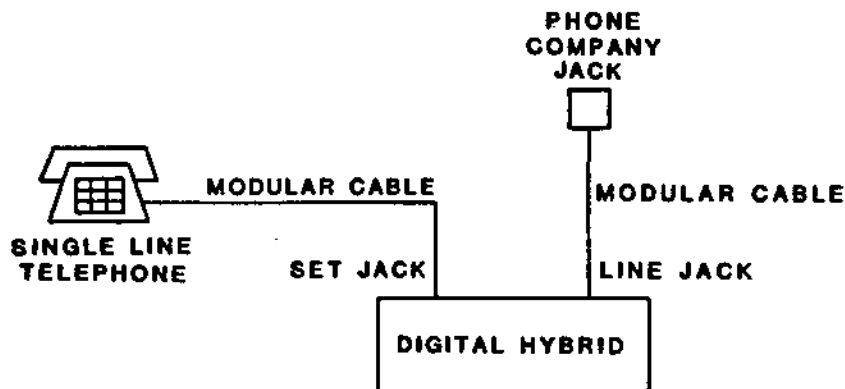

Diagram 2. Connection to single Central Office line

3.4 Connection to a 1A2 Key Service Unit

The Digital Hybrid may be used in conjunction with an existing 1A2 key service unit in one of three ways:

- A. Using an existing multi-line telephone set as a call director;
- B. Using an existing Gentner Telemix IX as a call director;
- C. Using a Gentner Telemix X as a call director.

Refer to the following discussion for detailed instructions.

A. Using an existing multi-line set:

Refer to diagram 3. The buttons on the existing multi-line set will provide the necessary line selection function for the Digital Hybrid. Remove the telephone's cover and locate the common tip and ring connections that go from the line selector button array to the telephone electronics network. Sever this connection, as shown in the diagram.

Connect the tip and ring wires coming from the line selector button array to the red and green conductors of a modular cable. The yellow and black conductors provide the A-lead closure and should be connected to the common A-lead at the telephone hook switch. This modular cable can now be connected to the LINE jack on the Digital Hybrid.

The red and green conductors of a second modular cable should be connected to the severed tip and ring of the telephone electronics network. Yellow and black conductors of this cable should be left unconnected. This second cable should be connected to the SET jack on the Digital Hybrid.

This installation will allow the multi-line instrument to operate as it normally would when the Digital Hybrid is off line. When the Digital Hybrid is placed on line, it will provide the necessary A-lead closure to light the selected line and it will automatically disconnect the telephone instrument's electronics network.

It is not possible to specify wire colors or terminal numbers in this manual due to the wide variety of telephone instruments and manufacturers of 1A2 equipment. Additional help can be obtained by contacting your telephone interconnect company or Gentner Customer Service.

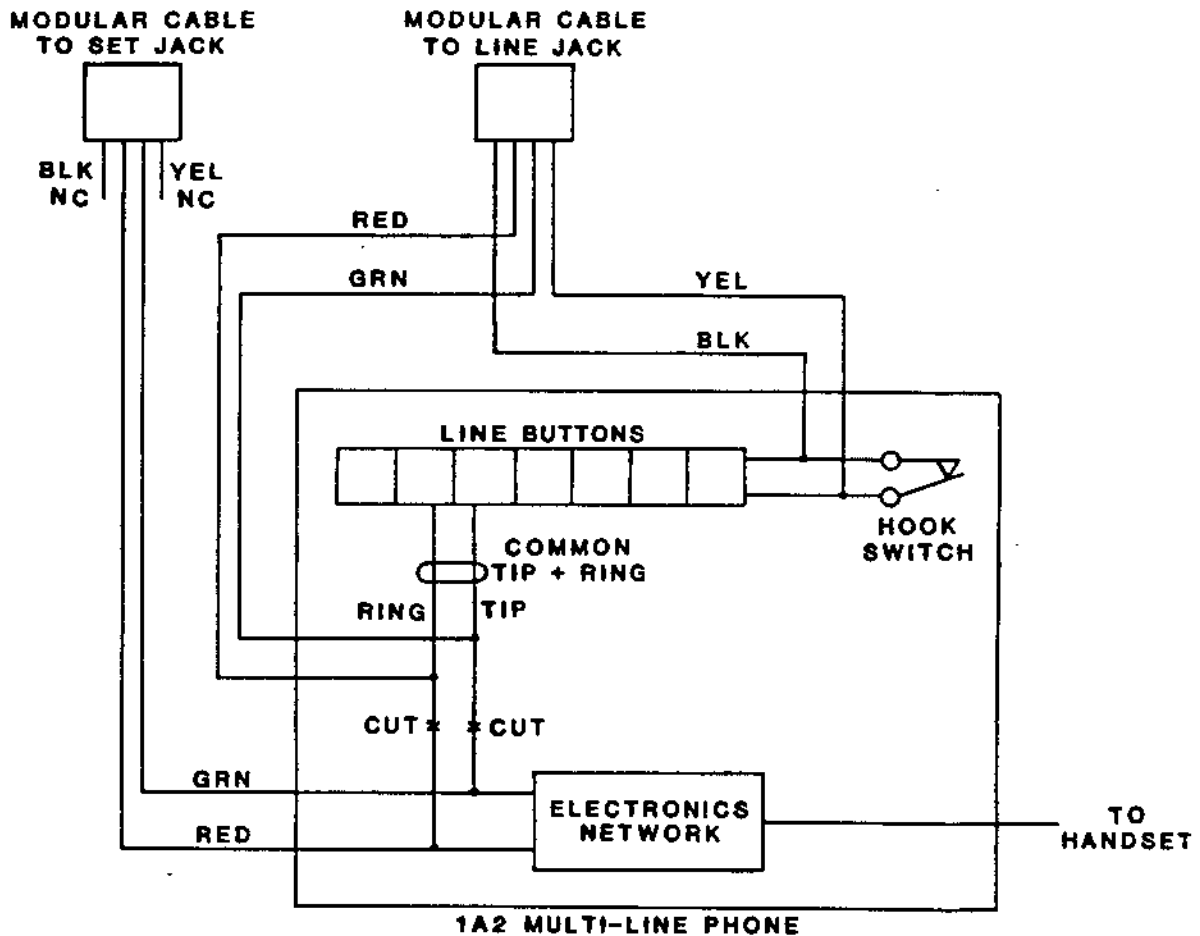

Diagram 3. Connection via multi-line 1A2 telephone set

B. Using an existing Gentner Telemix IX as a call director:

A simple method of connecting a Digital Hybrid to a Telemix IX uses one modular telephone cable. Strip one end of the cable and connect spade lugs to the red and green wires. Attach these wires to the Telemix IX rear barrier strip as follows:

To use the Digital Hybrid on the upper bus (lines 1 through 9), connect to barrier strip pins 1 and 2.

To replace the lower bus hybrid with the Digital Hybrid, connect to barrier strip pins 3 and 4.

The connectorized end of the modular cable will connect to

Digital Hybrid User's Manual Section Three: Installation

the Digital Hybrid's LINE jack.

NOTE: Two external hybrids are required to replace the hybrids in the Telemix IX system. Any combination of hybrids may be used; the best audio quality will be achieved through the use of two Digital Hybrids.

Open the Telemix IX; locate the Mascon connector on the audio board that routes to the rear panel barrier strip. Four jumpers are located on the audio board near this connector. These jumpers route tip and ring to the internal hybrids. Removal of the plug-in jumpers will disconnect the internal hybrids and allow external control via Digital Hybrids.

In the Telemix IX system, conferencing of upper and lower bus callers is accomplished on the audio board. When the internal hybrids are defeated, the system will no longer provide bus conferencing. This must be done by cross-connecting the external hybrids. Refer to section 3.10 for instructions on conferencing two Digital Hybrids.

Set the Digital Hybrid's option switch number 3, re-nulling enable, in the UP position. This setting will cause the Digital Hybrid to mute and re-null every time a new line is selected.

Solder a jumper between pins 18 and 36 on the supplied 37 pin female connector. Option switch number 4, momentary control enable, should be set in the the DOWN position. Plug the 37 pin female connector onto the Digital Hybrid's REMOTE connector. The combination of this jumpered connector and the option switch #4 setting will force the Digital Hybrid to be on line at all times. However, when the Telemix switches a telephone line to the hybrid, the unit will automatically null and unmute in the normal fashion.

This is a quick way of establishing Digital Hybrid operation with Telemix IX. The only drawback of this connection is a slight 'pop' in the audio when a line is placed on hold. A special cable and revision of Telemix IX software are available from the factory at a nominal cost; this will allow the Telemix IX to fully operate all remoted ON, OFF and muting functions of the Digital Hybrid. Contact Gentner Customer Service for complete details.

C. Using a Gentner Telemix X as a call director:

Connection of the Digital Hybrid to Telemix X is very easy. If the Digital Hybrids were ordered in conjunction with Telemix X, all necessary interconnect cables have been provided with the

system. These three cables are:

- (2) Digital Hybrid interface cables and
- (1) Universal Call Director cable.

Installation is very simple, as explained in the Telemix X manual. Simply connect the 25-pin connector on the Universal Call Director cable to its mating connector marked "Hybrid" on the rear panel of the Telemix X Call Director. Connect the small Molex connector marked "Hybrid 1" on the Universal Call Director cable to the Molex connector on one end of a Digital Hybrid Interface cable. Plug the 37-pin connector on the opposite end of the interface cable onto the REMOTE connector of the Digital Hybrid. Connect the second hybrid in a similar manner, using the small Molex connector marked "Hybrid 2."

3.5 Connection to Digital Key Service Telephones

Many broadcast facilities and offices employ new state-of-the-art telephone equipment that uses microprocessor controlled key service units. Even though many of these systems are referred to as "digital," the actual audio to the multi-line telephone instrument is carried on an analog balanced pair. Such systems can be interfaced to the Digital Hybrid.

Because of the number of different manufacturers and equipment of this type available, we can only explain in general terms how this interface may be accomplished. It is recommended that you contact your interconnect company prior to interfacing a Digital Hybrid to their equipment. Some manufacturers of digital telephone systems offer units (often called "jack sets" or "modem interface units") that bring out the necessary connections for interface to the Digital Hybrid.

Refer to diagram 4:

Most digital telephone systems connect to the key service unit with either a 4 or 6 wire modular connection cable. Unplug this cable from the telephone and carefully remove the set's cover. Locate the wires coming from the KSU connector. Two of these wires will contain the analog pair described above. The remaining wires are used for telephone power, intercom and microprocessor communications. In most digital telephones, this analog pair is found in the red and green wires. This can be verified by connecting a pair of high impedance headphones through a 10 uF capacitor across the suspected analog pair. The telephone instrument can then be connected to the KSU and a line selected. If dial tone is heard in the headphones, the analog pair has been located. Sever this pair between the jack and the

Digital Hybrid User's Manual Section Three: Installation

electronics of the telephone.

Prepare two telephone cables with modular connectors on one end of each with sufficient length to reach from the normal telephone position to the location of the Digital Hybrid. Connect the red and green wires of one of these cables to the analog pair coming from the KSU jack. Connect the yellow and black wires of this cable in parallel with the hook switch contacts of the digital telephone. This cable will connect to the LINE jack on the Digital Hybrid.

The red and green wires of the second modular cable should connect to the analog pair going to the electronics of the telephone set. The yellow and black cables of this wire are left unconnected. This cable connects to the SET jack of the Digital Hybrid. The telephone instrument can now be re-assembled and reconnected to the KSU.

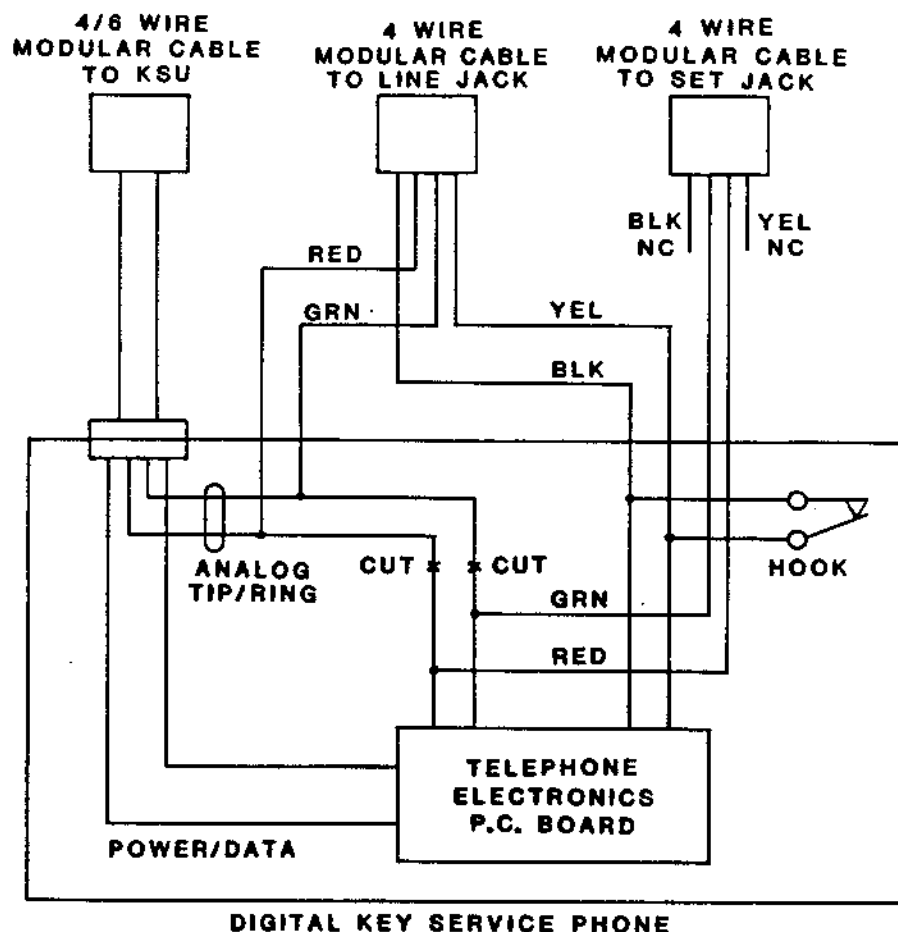

Diagram 4. Connection to "digital" telephones

Digital Hybrid User's Manual Section Three: Installation

This configuration allows the digital telephone to be used normally when the Digital Hybrid is off line. When the Digital Hybrid is on line, the analog path to the telephone electronics is automatically disconnected. In addition, the hook switch connection is closed, allowing line selection to be made on the telephone without having to lift the handset.

Gentner Engineering has considerable experience in interfacing our wide line of hybrid products to digital telephone systems. Contact Gentner Customer Service if you have any special questions or concerns that arise.

3.6 Connection to Audio Equipment

The basic function of the Digital Hybrid is to separate audio being sent to the caller (send audio) from audio being received from the phone line (caller audio). Diagram 5 illustrates this basic function:

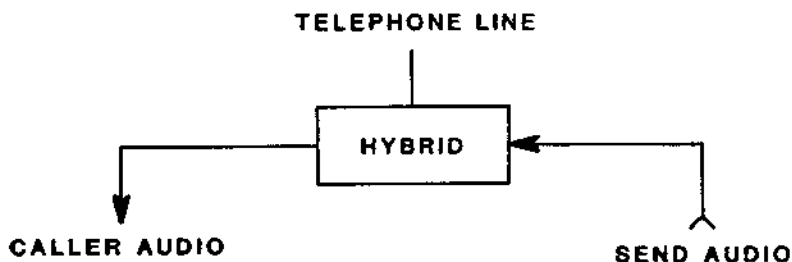

Diagram 5. Function of a telephone hybrid

The Digital Hybrid has been designed so that interface to audio equipment is both easy and adaptable to most user applications. Diagram 6 illustrates the four audio connections of the Digital Hybrid which include (MAIN) SEND, AUXILIARY SEND, CALLER OUT and MIX OUT. All four audio connections are made with XLRs.

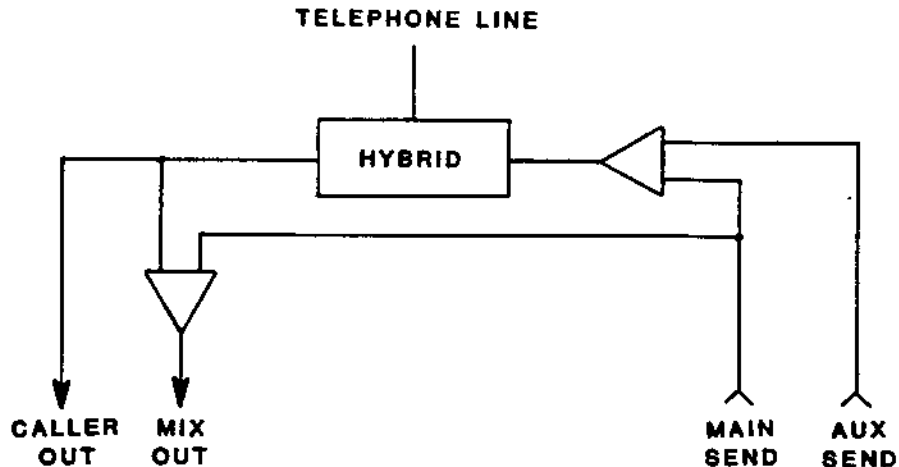

Diagram 6. Digital Hybrid Audio Connections

The Auxiliary Send (labeled AUX on the Digital Hybrid) provides a balanced, bridging line level send input to the device.

The Main Send (labeled SEND) is balanced, bridging and may either be mic or line level depending on the position of the switch located near the connector.

The send inputs will contain the audio to be sent to the caller.

CAUTION! This audio should not contain any of the caller's audio as this can create feedback and oscillation.

The Mix Out provides a balanced, line level sum of the Main Send and Caller Out Audio. It should be noted that the Auxiliary Send audio does not appear at this output.

The Caller Out is caller audio only. It too is balanced at line level.

All four connections are made via XLR cables to your equipment. If a mixing console will be used to feed the SEND input of the Digital Hybrid, the audio going down the line must not contain any caller audio. There are several ways to accomplish this:

1. Creation of a separate mix channel: If the console has an extra mixing output channel, use this channel to mix all audio you want to send to the Digital Hybrid, EXCEPT the channel that

Digital Hybrid User's Manual Section Three: Installation

will be connected to Caller audio.

2. Internal mix-minus bus: Many console manufacturers now provide an internal mix-minus bus designed for this purpose. Mix-minus refers to a sum of the audio sources in the console MINUS caller audio.

3. "Build your own" mix-minus: It is possible to build your own mix-minus bus by resistively summing all audio sources to be sent down the phone line. Be careful to provide isolation between channels. Contact Gentner Customer Service for details.

4. Discrete mic mixer: If only microphone audio will be sent down the line, a separate mic mixer may be utilized. This audio can then be sent to the send input of the Digital Hybrid as well as the input of the console.

5. One Channel Send. If a single source of audio will be sent to the caller (such as a microphone), simply use this audio. The SEND XLR can be selected for either mic or line level via the adjacent switch.

The CALLER output XLR will be connected to a separate channel of an audio console or the the input of an audio amplifier. This will allow monitoring of caller audio.

The MIX XLR contains a sum of both send and caller audio. This audio combination is useful for recording both sides of the telephone conversation.

3.7 Adjustment of Front Panel Trimmers

Once audio connections have been made, the SEND and CALLER trimpots should be adjusted for appropriate levels. The following steps should be taken:

A. Adjustment of SEND trimmer:

Remove the front access panel. Note that the reverse side of the access panel shows the location of the trimmers and designates the functions of the user option switches. Locate the SEND trimmer potentiometer (to the left).

Apply normal SEND audio while depressing the OFF switch on the Digital Hybrid. Adjust the SEND trimmer so that the front panel SEND LED glows green on normal audio and occasionally red on peaks.

B. Adjustment of CALLER trimmer:

Locate the CALLER trimmer (to the right). Initiate a telephone call and depress the Digital Hybrid's ON button. While the caller is speaking, adjust the CALLER trimmer potentiometer for the proper output level to your equipment.

C. Adjustment of CALLER CONTROL:

The CALLER CONTROL feature of the Digital Hybrid automatically reduces the level of the caller audio when send audio is present. The purpose of this control is to provide dominance over the caller simply by speaking normally. The amount of this caller reduction is determined by the Caller Control trimmer (the center trimmer).

Turning the trimmer clockwise increases the amount of reduction. A fully clockwise position will result in approximately 40dB of caller dimming, creating an effect similar to a "speakerphone." The trimmer may be set for any amount of reduction desired.

For most broadcast applications, we have found that 8dB of caller reduction allows the announcer to always be "on top" of a telephone conversation. The 8dB setting allows the caller to still be heard clearly in a "double-talk" situation. One additional advantage of slight caller reduction is that the hybrid return product is reduced 8dB when the announcer speaks, further enhancing the superb performance of the Digital Hybrid.

To remotely adjust the caller control connect a 1K ohm linear taper pot to pins 12 and 30 as shown in diagram 7.

It should be noted that when the remote Caller Control potentiometer is connected, the front panel Caller Control trimmer is electronically disabled by the Digital Hybrid. Additionally, operation of either Caller Control can be discontinued by setting option switch #7 to the DOWN position.

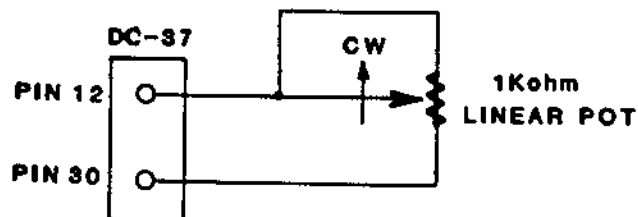

Diagram 7. Connection of remote Caller Control pot.

3.8 User Option Switches

These switches are numbered 1 through 10, left to right, as viewed from the front.

#1: Auto Answer enable. With this switch in the UP position, the Digital Hybrid will automatically answer a telephone line when the appropriate ringing voltage is present. To obtain the best possible hybrid null, the microprocessor waits for one complete ring before answering the line. When the unit answers the line, it automatically goes through the same nulling procedure as if the front panel ON switch had been depressed.

#2: Auto Disconnect enable. With this switch in the UP position, the unit will automatically disconnect from the telephone line when telephone line loop current is either removed or reversed. Most central offices provide this as an indication that the calling party has hung up. When loop current is dropped, the microprocessor immediately mutes caller audio to prevent the loud "pop" of the DC interruption from reaching the audio equipment.

#3: Re-null and mute enable. With this switch in the UP position, the Digital Hybrid will automatically go through the nulling/muting process every time telephone loop current is dropped and then re-established. When the line is dropped, the Digital Hybrid will mute receive audio. When the line returns, it will re-null and unmute the caller audio. This allows the unit to be used with very simple call directors such as those found on a multi-line 1A2 telephone instrument. The microprocessor will automatically provide the muting function necessary for a smooth, "popless" transition from line to line. When switch #3 is in the UP position, the operation of switch #2 (auto disconnect) is disabled.

#4: Momentary control enable. This switch is normally used in the UP position so that the Digital Hybrid can be placed on and off line using the front panel ON/OFF momentary switches. The ON/OFF switches are also remoted on the 37 pin connector on the rear panel. The Digital Hybrid may be remotely controlled using either a momentary or sustained closure. If the user's equipment provides a sustained closure output, option switch #4 should be placed in the DOWN position. When this closure is made on the remote connector's ON pin, the hybrid will go through the nulling procedure described previously. When the closure is open, the hybrid will return to the off line state.

Connection diagrams are shown in section 3.9.

#5: Send processor enable. When this switch is in the UP position, the Digital Hybrid's send processor will be operational. The processor can be used to guarantee that a consistent level is sent to the caller. When switch #5 is in the DOWN position, the send amplifier will revert to unity gain. However, a limiter circuit in the send amplifier will ensure that the send audio level never exceeds -12dBm on the telephone line, keeping the unit well within FCC part 68 specifications.

#6: Caller processor enable. With this switch in the UP position, the Digital Hybrid's receive processor will be operational. The processor can be used to guarantee consistent caller audio levels from line to line. When switch #6 is in the DOWN position, the receive amplifier is forced to unity gain.

#7: Caller Control enable. With this switch in the UP position, the Caller Control circuitry is enabled. If switch #7 is in the DOWN position, the front panel Caller Control trimmer (or remoted Caller Control pot) will be disabled.

#8: Port conference disable. With this switch in the UP position, the port conferencing function of the Digital Hybrid is disabled. Port conferencing forces the Digital Hybrid into a half-duplex mode. When the caller speaks, and his amplitude is detected on the front panel CALLER LED, send audio is electronically switched off. This function can be very useful in teleconferencing to eliminate conference room acoustic echo from being sent back to the caller. In broadcast uses, switch #8 would normally be set in the UP, or disabled, position.

#9 and #10: Spare. The current version of software does not utilize these switches.

3.9 Remote control of Digital Hybrid Functions

The ON and OFF functions of the Digital Hybrid may be remoted if desired. This may be done either by separate momentary ON and OFF switches or by a single toggle switch. If momentary switches are used, user option switch #4 must be in the UP position; if a toggle switch is used, option switch #4 must be DOWN.

Diagram 8 illustrates both methods of remote control.

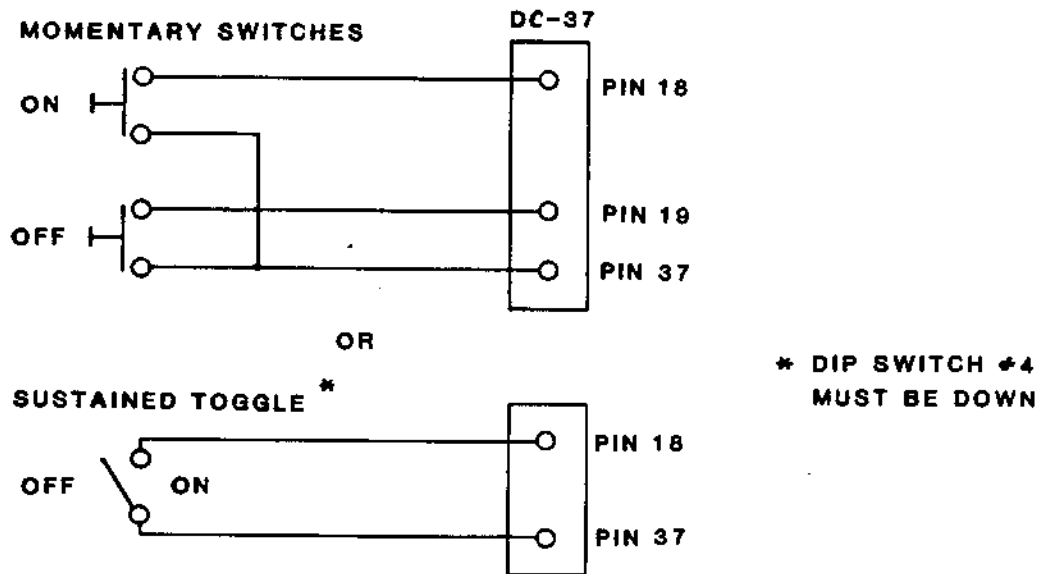

Diagram 8. Methods of remote ON/OFF control

A remote mute switch (to mute caller audio output) can be connected to the DC-37P remote connector pins 17 and 35 in a similar manner to that shown in the previous diagram.

The Digital Hybrid can be remotely placed in the port conferencing mode by applying a voltage between 4 and 25V to the DC-37P pins #11 (positive) and #29 (negative).

In addition to the ON/OFF functions, the four front panel LED indicators can also be remoted. Diagram 9-A shows the typical remoting of the ON LED. Pin 15 of the DC-37 remote connector is an open-collector output that connects to the cathode of the remote LED; pin 33 provides +5V through a 180 Ohm resistor for current limiting.

Diagram 9-B shows how an incandescent lamp could be remoted as the ON indicator. An external power supply that provides the lamp voltage is required.

Additionally, an external relay could be driven from any of the four remote indicator outputs (ON, OFF, Send, Caller) for various applications, i.e. activation of a digital delay. A sample configuration of a relay connection is shown in diagram 9-C. Again, an external power supply capable of providing the relay's coil voltage is required.

Digital Hybrid User's Manual Section Three: Installation

Each of the four indicator outputs is capable of driving 100mA with a maximum external supply voltage of 40V.

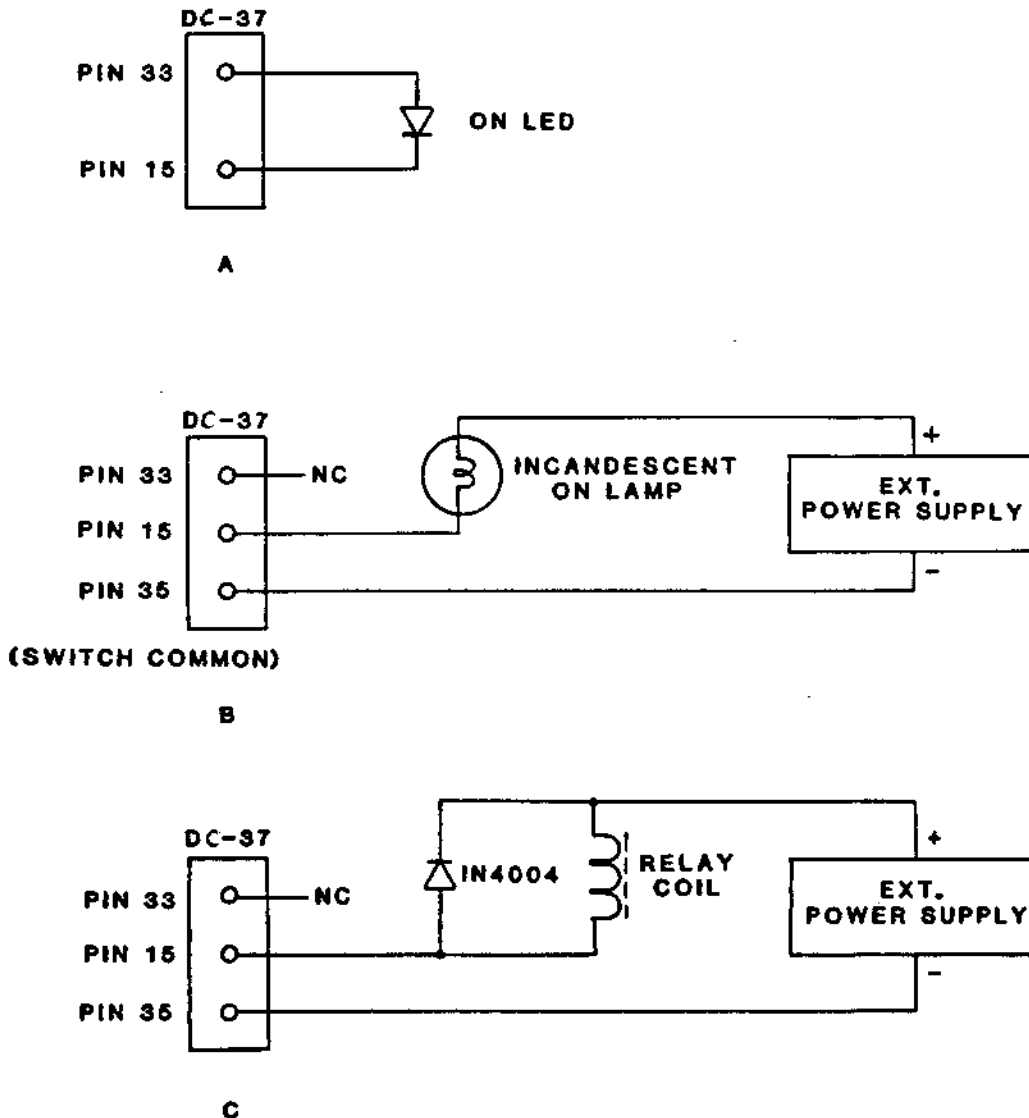

Diagram 9. Remote Indicator Connections

The remote connector on the rear panel of the Digital Hybrid also contains paralleled connections to each of the four XLRs and two RJ-11C telephone jacks.

To remotely adjust the caller control connect a 1K ohm linear taper pot to pins 12 and 30 as shown in diagram 10.

Digital Hybrid User's Manual Section Three: Installation

It should be noted that when the remote Caller Control potentiometer is connected, the front panel Caller Control trimmer is electronically disabled by the Digital Hybrid. Additionally, operation of either Caller Control can be discontinued by setting option switch #7 to the DOWN position.

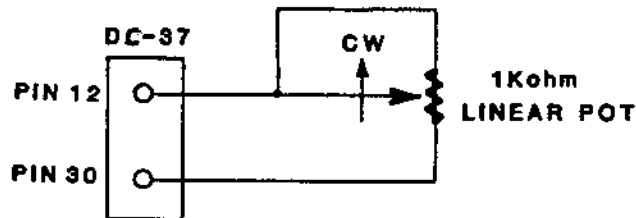

Diagram 10. Connection of remote Caller Control pot

A summary of the DC-37P remote connector pinout is as follows:

1 -- Set Tip	20 -- Set Ring
2 -- Line Tip	21 -- Line Ring
3 -- A1	22 -- A Common
4 -- Protective ground	23 -- Protective ground
5 -- Protective ground	24 -- Balanced Mix Out -
6 -- Balanced Mix Out +	25 -- Balanced Caller Out -
7 -- Balanced Caller Out +	26 -- Analog ground
8 -- Analog ground	27 -- Balanced Aux Send -
9 -- Balanced Aux Send +	28 -- Balanced Send In -
10 -- Balanced Send In +	29 -- Port Conference -
11 -- Port Conference +	30 -- Caller Control Return
12 -- Caller Control Pot	31 -- +5V / 180 Ohm
13 -- Send Indicator	32 -- +5V / 180 Ohm
14 -- Caller Indicator	33 -- +5V / 180 Ohm
15 -- ON Indicator	34 -- +5V / 180 Ohm
16 -- OFF Indicator	35 -- Switch Common
17 -- Mute switch	36 -- Switch Common
18 -- ON switch	37 -- Switch Common
19 -- OFF switch	

3.10 Multiple Unit Conferencing

Multiple Digital Hybrid units can be conferenced for the airing of multiple callers or for use as a telephone conference bridge. Diagrams 11, 12 and 13 show three methods of conferencing two units for different applications.

Digital Hybrid User's Manual Section Three: Installation

Diagram 11 is a talk show application where an out of studio guest is to participate via a dedicated telephone line. The second hybrid, connected to a multi-line telephone, is conferenced to the guest hybrid. In this configuration, both callers can hear the studio announcer and each other in a fully amplified conference. Separate caller and guest caller audio signals are available for application to two console channels.

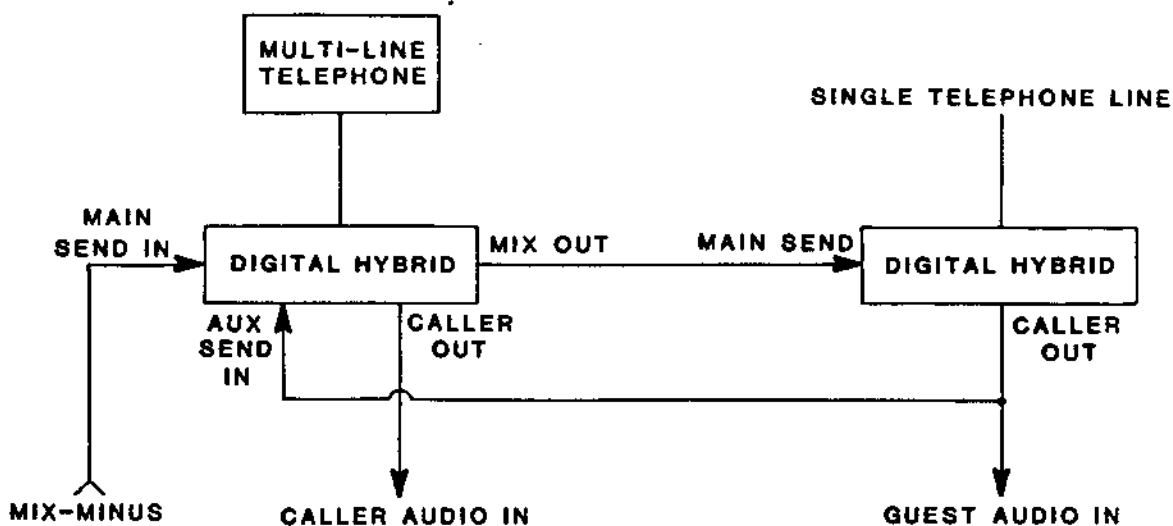

Diagram 11. Conference with multi-line and dedicated guest line

Diagram 12 shows two Digital Hybrids that could be connected to either dedicated or multi-line call directors. When connected to multi-line call directors, absolute diversity in placing two callers in a fully amplified conference could be achieved. In this configuration, both callers would hear the studio announcer and each other. Separate caller audio outputs are available for application to the mixing console.

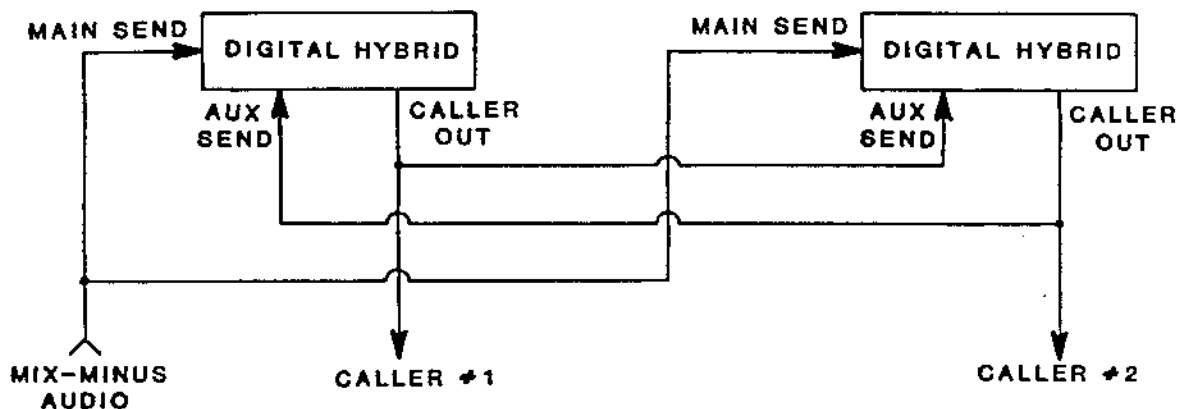

Diagram 12. Dual hybrid conference with separate audio outputs.

Diagram 13 shows two Digital Hybrids in a conference setting where both caller outputs are mixed together for application to one console input.

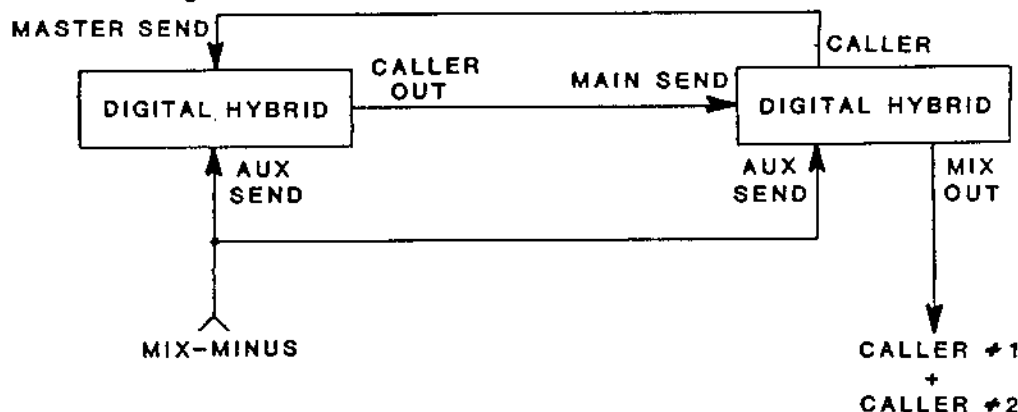

Diagram 13. Dual hybrid conference with mixed output.

Additional units could be stacked, in a similar manner to those shown above, depending on individual applications. If a particularly large architecture or unique application is desired, please contact Gentner Customer Service for assistance.

SECTION FOUR

OPERATION

4.1 Basic Operation

The Digital Hybrid was designed for simple operation in a variety of applications. Once the unit has been properly installed, the only function required by the operator is the depression of the ON button. Whenever the unit is on line, the ON button may be redepressed, causing the unit to renull and mute the output audio. The unit will stay muted until the ON button is released. To deactivate the unit the OFF button is depressed.

4.2 Typical Broadcast Application

Diagram 14 shows how a typical broadcast station would use the Digital Hybrid. A multi-line telephone is used to select a telephone line to be routed to the Digital Hybrid. When the talent desires to go on-air with the call, the ON button (remoted) is depressed. This causes the following to occur:

- A. The selected phone line is terminated.
- B. A burst of white noise is sent down the phone line.
- C. The hybrid automatically nulls to the noise burst.
- D. 300 milliseconds later the output audio is unmuted and the caller is routed to the input of the console.

The muting function is useful in broadcast applications because it masks the termination pops and clicks, making telephone connection clean and clear.

If the caller processor is activated (selected by the option switch), the output level to the console is maintained at a consistent level.

Audio from the mix minus output of the console is routed to the caller. If the send processor is activated (a switch option), the input level to the caller is kept consistent.

The unit continues to automatically null whenever there is send audio present but stops when caller audio is present.

In this application, the unit should be selected for renull on loop drop (option switch), allowing the talent to select another line on the telephone without depressing any buttons on the Digital Hybrid. In this mode of operation, the following

occurs on line selection:

- A. The unit senses loop drop.
- B. The caller output audio is muted.
- C. The unit senses selection of the next line.
- D. The nulling/unmute process is repeated.

This mode of operation provides clean connection to each selected telephone line, with maximum hybrid performance ensured.

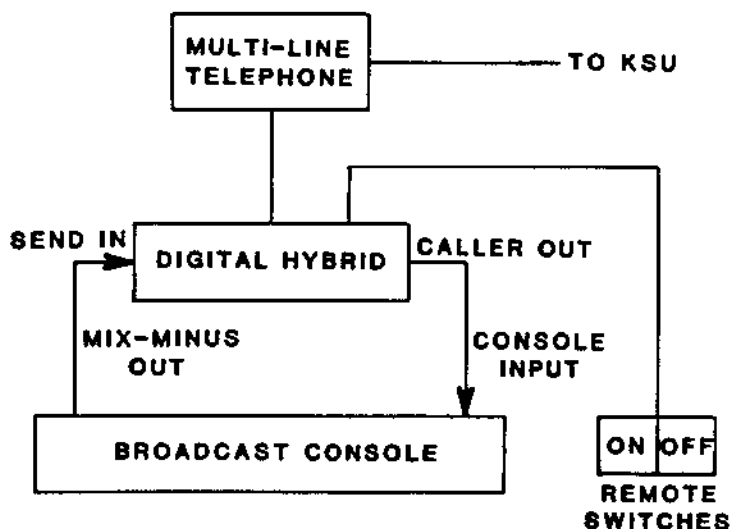

Diagram 14. Typical broadcast operation

Multiple callers may be conferenced, as described in section 3.10 of this manual, using two or more Digital Hybrids. Each hybrid would be cross-connected to the other hybrid(s) so that the callers could hear each other.

4.3 Teleconferencing Use

The Digital Hybrid was specifically designed for teleconferencing. Diagram 15 illustrates a typical conference room setup. The major advantage of this system is that the participants can listen while talking...the speaker is not turned off as it would be on a speakerphone. This permits a more natural conversation between boardrooms, without annoying cut-offs.

In this setup, four directional microphones are mixed together. The output of the mixer is sent to the SEND input of the Digital Hybrid. The CALLER output of the Digital Hybrid is sent to the input of a power amplifier. The power amp drives a speaker that is placed in the middle of the conference room table. The placement of the directional microphones and speakers are important to maximize acoustic isolation.

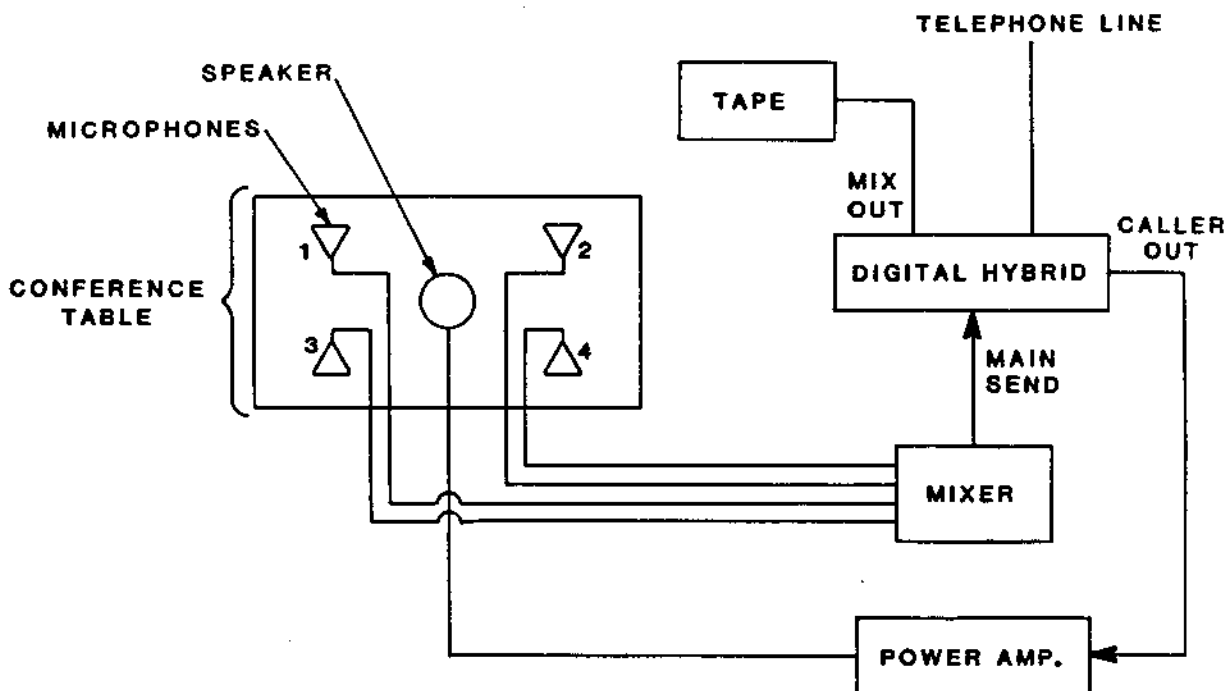

Diagram 15. Conference room setup

4.4 Auditorium or meeting use

The Digital Hybrid can be used to provide conferencing in an auditorium, church, arena or other large area. As shown in diagram 16, the caller is heard through loudspeakers while anyone speaking on a microphone is heard by the caller. This permits guests to speak at large get togethers without requiring them to be on location.

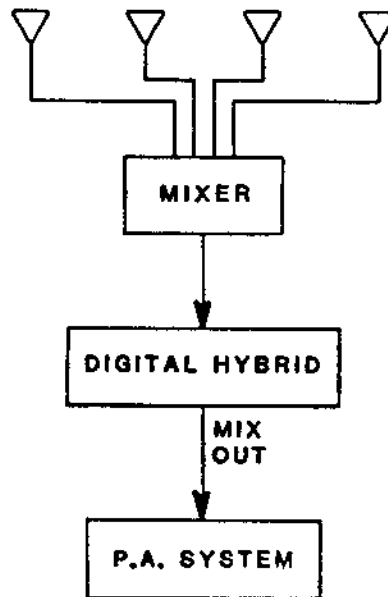

Diagram 16. Auditorium setup

The Digital Hybrid is adaptable to many different applications. For setup assistance, contact Gentner Customer Service.

Digital Hybrid User's Manual Section 5: Technical Description

SECTION FIVE

TECHNICAL DESCRIPTION

Please refer to the system block diagram on the next page as you read the following technical description.

5.1 Send Audio Circuit

Audio that is to be sent to the caller is applied at the SEND input on the rear panel of the Digital Hybrid. This input can be either microphone or line level. When the switch adjacent to this connector is in the mic position, its preamplifier circuit applies 55 dB of gain to the input level. The output of this amplifier is fed to two places, one being the front panel send level potentiometer, the other being the MIX output amplifier.

An additional send audio input is available at the AUX send connector on the rear panel of the Digital Hybrid. This connector has a unity gain balance amplifier. Its signal is not applied to the send level potentiometer, but is mixed with the output of the main send input to be applied to the telephone send circuit. This fixed gain auxiliary input provides for easy conferencing of multiple Digital Hybrids.

After these two send signals are mixed together, their combined level is presented to an analog switch and a level set circuit that is comprised of two analog comparators and some digital logic circuitry. This level set circuitry drives a red/green LED that can yield a quick indication of level into the Digital Hybrid. The green LED will light when the audio level is adequate to properly gate the send ACG and telephone line limiter's circuitry. The window of this green LED is approximately 14 dB in level. When the signal reaches +10 dBm, the red LED turns on to indicate that the dynamic range of the send circuitry is close to being compromised. There is an additional 10dB of headroom above the point where the red LED lights.

The Digital Hybrid's microcontroller provides the control logic to the analog switch circuit. When the Digital Hybrid is in the off mode, the analog switch is left open, providing no send audio to the telephone circuit. When the ON button is depressed, the microcontroller provides the necessary logic to have the analog switch connect the noise generator to the send circuit. 300 milliseconds of noise is provided to allow the Digital Signal Processor (DSP) to properly null the hybrid.

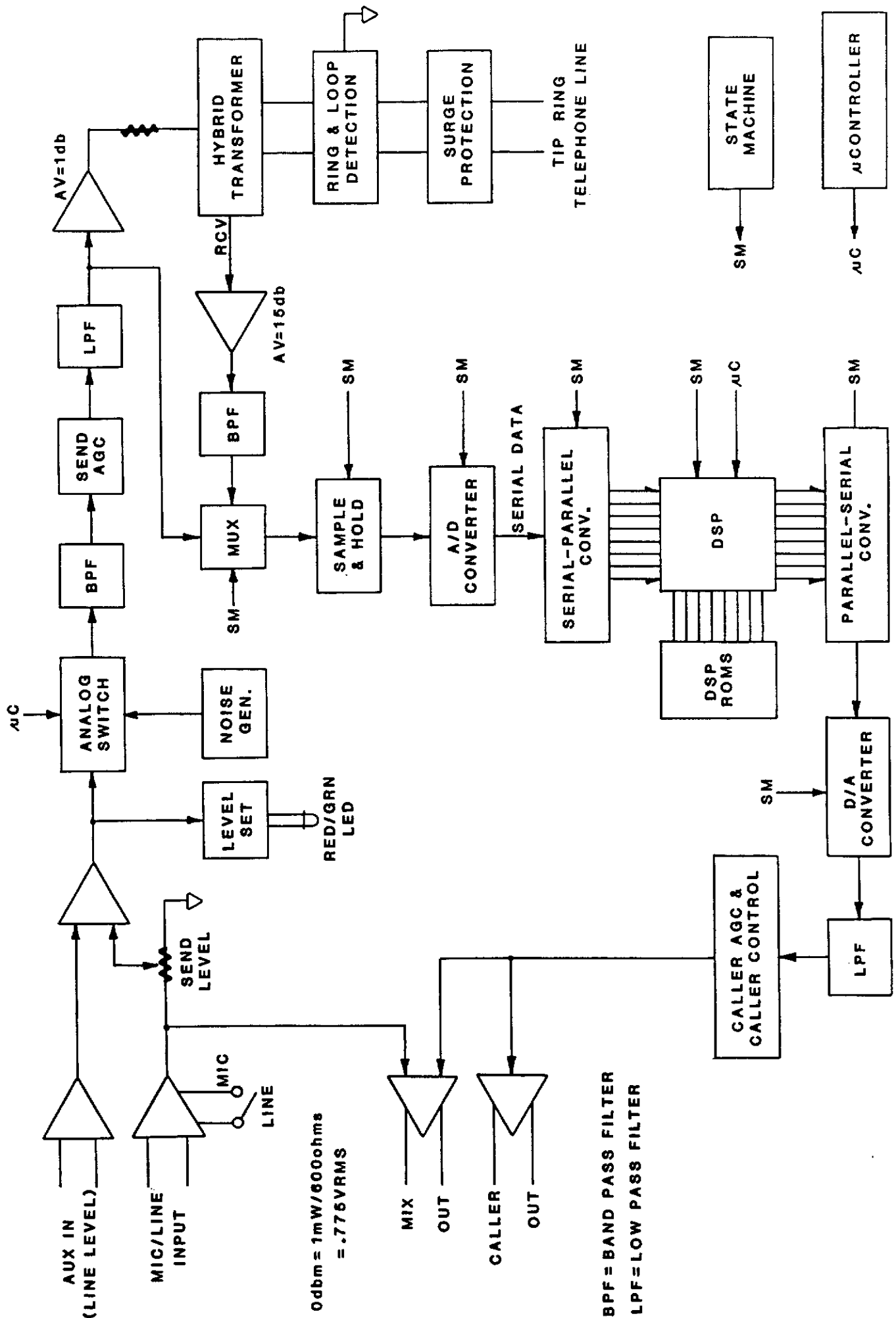

Digital Hybrid System Block Diagram

Digital Hybrid User's Manual Section 5: Technical Description

After this nulling process has taken place, the microcontroller sends logic to the analog switch which causes send audio to be sent to the caller. If the Digital Hybrid is in the port conferencing mode when the caller speaks (and is detected on the front panel caller LED), the microcontroller will additionally turn off this analog switch, gating send audio to the caller off.

The output of this analog switch is fed to the bandpass filter. The frequency response of this filter has been carefully designed to provide the best compromise between send audio intelligibility and hybrid nulling performance. The one dB bandwidth of this filter is 350 to 2550 Hz. The 30 dB response of this filter is 190 to 3100 Hz.

Audio at the output of the bandpass filter is applied to the send AGC circuit. The send AGC circuit has been designed with a gate threshold of -26 dBm. When audio crosses this threshold, the send AGC will provide up to 15 dB of gain to increase the amplitude of the send audio to a listenable level. As send audio of a higher magnitude comes into the send AGC, the send AGC will provide up to 20 dB of gain reduction, thus attempting to keep a consistent level to the caller on the telephone line. Any time the send audio drops below the minus 26 dB threshold, the send AGC reverts to unity gain. A dip switch on the front panel can also disable the send AGC, causing it to revert to unity gain.

The send AGC contains a limiter circuit to protect the telephone line from excessive amplitude. This limiter circuit functions whether the send AGC is enabled or disabled. The output of the send AGC is applied to a low pass filter. This low pass filter serves as an anti-aliasing filter for the process of digitizing the send audio to be sent to the DSP. Audio out of this anti-aliasing filter is applied to the input of the analog multiplexer. This audio is additionally buffered with a unity gain buffer and a 600 Ohm sourcing resistor, and applied to the SEND winding of the hybrid transformer.

5.2 Telephone Line Circuitry

The tip and ring conductors of the telephone line are applied to a RJ11C connector on the Digital Hybrid. Tip and ring are then routed thru a fusing resistor and surge protection circuitry. This protects hybrid circuitry from telephone line surges caused by lightning or other electrical events.

Tip and ring are then routed thru a circuit that provides for detection of ringing voltage and also the detection of telephone loop current. The signals are then sent through the

Digital Hybrid User's Manual Section 5: Technical Description

microcontroller so that the microcontroller can determine if the telephone line is "ringing," or whether after going off hook the telephone line has been disconnected from the central office.

As tip and ring progress through this circuitry they are applied to the primary of the hybrid transformer. The hybrid transformer has been designed to provide adequate coupling and a small amount of hybrid isolation in the presence of up to 70 milliamps of telephone company loop current.

5.3 Caller (Receive) Audio Circuitry

The telephone hybrid transformer has a winding on which receive audio from the telephone call will appear. The output of this winding is applied to an amplifier where 15 dB of gain is achieved. Output of this amplifier is fed to the receive bandpass filter. The receive bandpass filter has been designed with a one dB bandwidth of 240Hz to 3kHz and a 30 dB bandwidth of 130 to 420Hz.

This filter then allows caller audio to pass with excellent fidelity, while eliminating telephone line hum at both 60 and 120Hz in addition to low frequency telephone company signaling noise. The response at the high frequency end of the filter provides for the elimination of telephone company multiplex noise and also serves as the anti-aliasing filter for the digitization of caller audio.

Audio out of this bandpass filter is applied to an analog multiplexer. The Digital Hybrid has a ROM-based state machine which generates all the necessary timing waveforms that provide for the digitization of both send and caller audio, and the digital to analog conversion of audio out of the DSP. Audio in the Digital Hybrid is digitized at the rate of 10,000 samples per second. During this one ten thousandth of a second interval the analog multiplexer first selects the SEND audio and applies it to the sample and hold circuit. The sample and hold circuit effectively takes a snapshot of the moving analog send signal and momentarily holds it at a finite value. This finite value is then applied to the analog to digital convertor.

The analog to digital convertor produces a 14 bit number that represents the amplitude of this finite sample. Serial data from the analog to digital convertor is changed into a parallel format for presentation to the DSP.

After this process of digitization of the send audio has taken place, the analog multiplexer switches over to the caller audio circuit. Caller audio is then digitized in the same manner

Digital Hybrid User's Manual Section 5: Technical Description

and its digital value presented to the DSP in a parallel format.

The Digital Signal Processor, in conjunction with its associated instruction ROMs, implement an automatic adapting finite impulse response filter. The DSP takes 30 consecutive samples of send and caller audio and compares them in such a way that it can automatically adjust this finite impulse response filter to provide the best overall subtraction of send audio from caller audio. To achieve this, the DSP performs 60 multiplications, 60 additions, and 70 data register moves in one sample period of one ten thousandth of a second.

Each time this mathematical process is done the DSP produces one fourteen bit sample of caller-only audio that is fed to a parallel to serial convertor. Serial data out of this convertor is fed to a digital to analog convertor that performs the reverse process of taking a finite digital sample and turning it into a finite analog quantity. These finite steps one ten thousandth of a second wide are then smoothed into a continuous analog signal by the low pass filter. The output of this low pass filter then drives the caller AGC and caller control circuit.

The caller AGC is very similar to the send AGC, except that while providing the same gain reduction of 20 dB the caller AGC is shelved at a positive gain of 10 dB. The caller AGC can additionally be disabled via a front panel option switch, reverting the caller AGC to unity gain. This circuit also provides caller control, meaning that when there is send audio present in the Digital Hybrid, the caller can be dimmed by an adjustable number of decibels. The amount of dimming is determined by the front panel caller control trimmer, or the remotely connected caller control pot.

Audio out of the caller AGC and caller control circuit has been applied to a balance amplifier to provide the balanced caller out signal. Additionally, this audio provides an input to the mix output amplifier. The mix output contains the sum of the send input signal and the caller. This output is ideally suited to drive an audio tape recorder, which will then provide for the recording of both sides of the telephone conversation.

SECTION SIX

GENTNER ENGINEERING CUSTOMER SERVICE

6.1 Gentner Customer Service

The Digital Hybrid was designed for flexibility in setup and use. As a result, questions may arise during installation of the unit that are not covered in this manual.

Gentner Customer Service is available during regular business hours to provide assistance or to answer questions regarding installation and operation of the Digital Hybrid.

Please note, however, that most of the common questions asked regarding installation of telephone products are answered within this manual! In many cases, a careful re-reading of a section will provide the solution to an installation problem.

We welcome your comments and suggestions regarding the Digital Hybrid. Our Sales and Customer Service personnel can also help with questions about other applications using Gentner products. Please address your comments to:

Gentner Engineering Company, Inc.
Attn: Customer Service
540 West 3560 South
Salt Lake City, Utah 84115

6.2 Warranty Repair Procedures

If your Digital Hybrid is defective, please call Gentner Customer Service at (801) 268-1117. Problems frequently can be solved over the telephone, eliminating the need to remove the product from service.

Any products returned to Gentner Engineering for repair must have a return authorization number. This number can be obtained by calling Gentner Customer Service. Please mark the R.A. number clearly on the shipping container. We would also appreciate a note attached to the unit which clearly states the problem(s) being experienced with the product.

The product should be repaired within FOUR WORKING DAYS of receipt and will be returned by UPS Surface (overseas shipments will be returned by the carrier that brought the product). If faster shipment is desired, the shipping cost must be prepaid by the customer.

If you are not certain whether your Digital Hybrid is covered by warranty, refer to section 1.4 of this manual or contact Gentner Customer Service.

ENGINEERING CHANGE ORDER STATE:

REV.	DATE	BY	CHKD.
1.3		W. J. CASE	
1.4		W. J. AMERINGER	

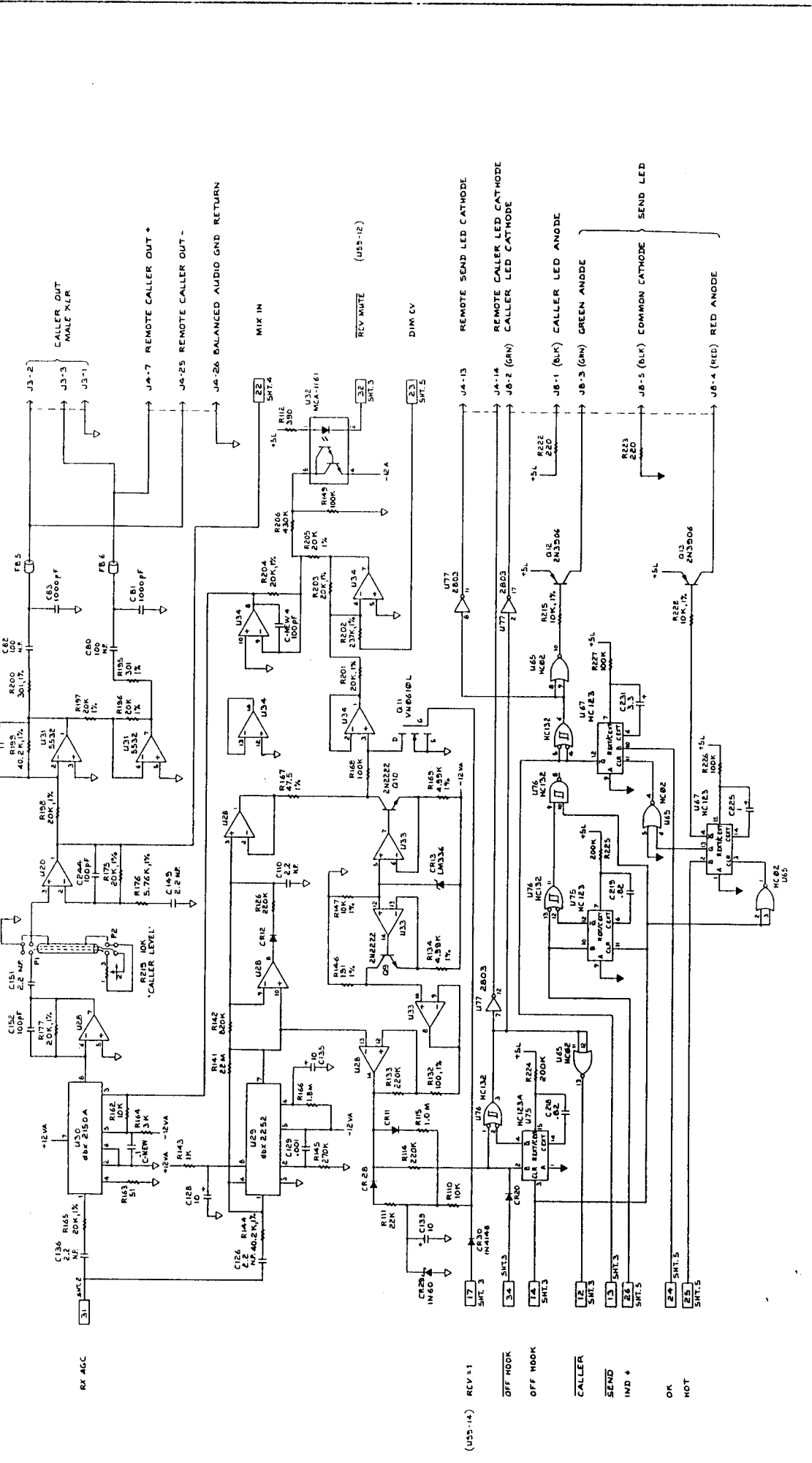

GENTNER ELECTRONIC - LITTLE	
DIGITAL HYBRID SCHEMATIC	
REV. 1.4	DATE 8-1-77
DESIGNED BY W. J. AMERINGER	CHECKED BY W. J. CASE
710-009-001 D 6-7 14	

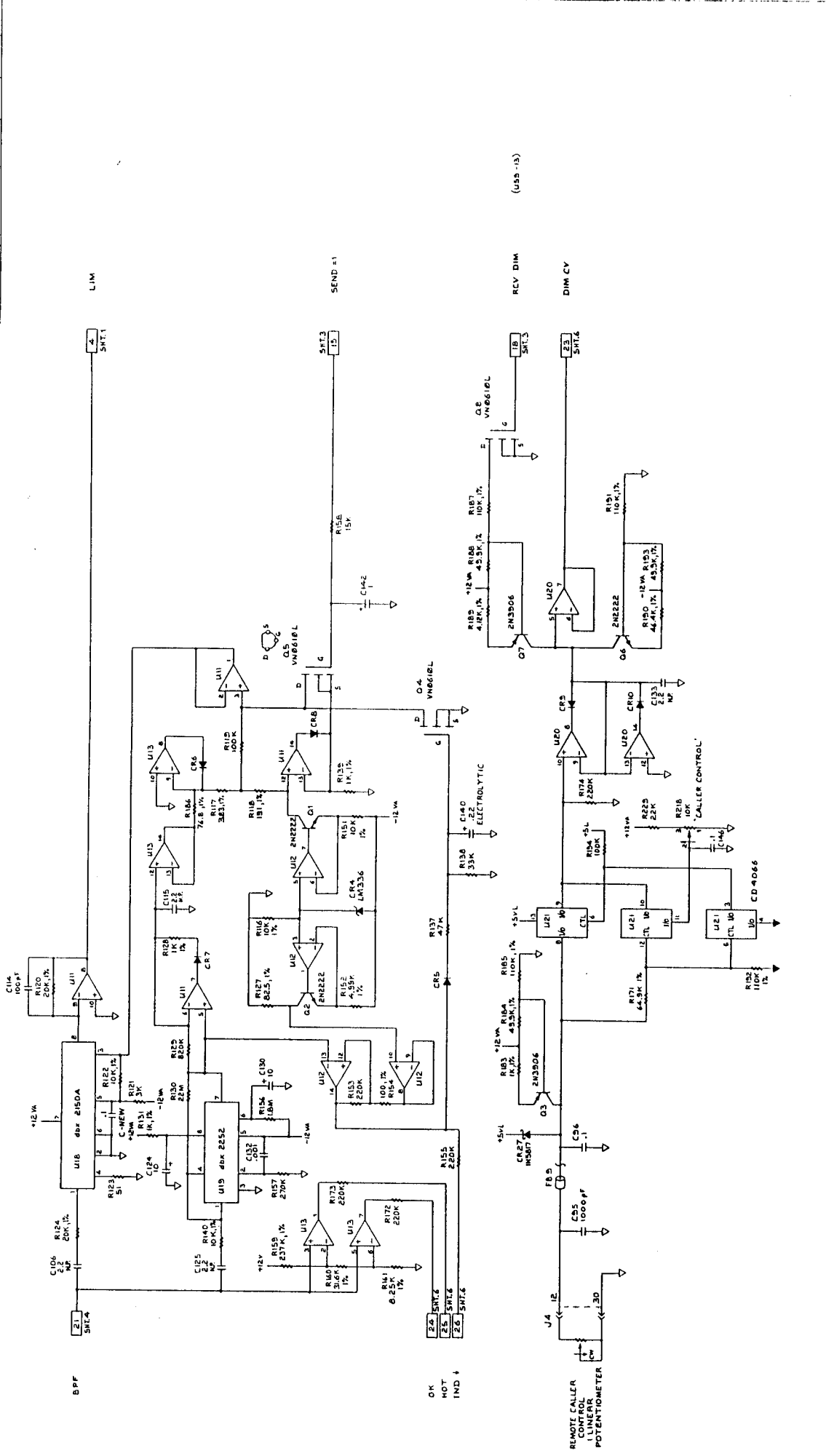

ENGINEERING CHANGE ORDER 512105			
REV	DATE	DESCRIPTION	BY
1	10/15/03	INITIAL DESIGN	W. J. B.
2	11/10/03	PROD. RELEASE	W. J. B.
3	12/15/03	SMT_2 AMENDED	W. J. B.
4			

ENGINEERING CHANGE ORDER 512105			
REV	DATE	DESCRIPTION	BY
1	10/15/03	INITIAL DESIGN	W. J. B.
2	11/10/03	PROD. RELEASE	W. J. B.
3	12/15/03	SMT_2 AMENDED	W. J. B.
4			

DSP DATA BUS	IO	SMT_2, 3
RES DSP	11	SMT_3
TRQ DSP	23	SMT_2
6 Mhz	7	SMT_2
LOAD	6	SMT_2
K FACLEN	20	SMT_3
OFFSET EN	19	SMT_3
REV EN	28	SMT_2
SEND EN	3	SMT_2
REMOTE SEND	J4-28	
J5	J5-2	
SEND XLR (FEMALE)	J5-1	
J5 GND	J5-GND	
REMOTE SEND +	J5-3	
REMOTE SEND -	J4-10	
BALANCE AUDIO	J4-8	
RETURN	J4-9	
REMOTE AUX SEND +	J4-9	
REMOTE AUX SEND -	J4-27	
J6	J6-2	
AUX SEND XLR (FEMALE)	J6-3	
J6-1	J6-1	
J6 GND	J6-GND	

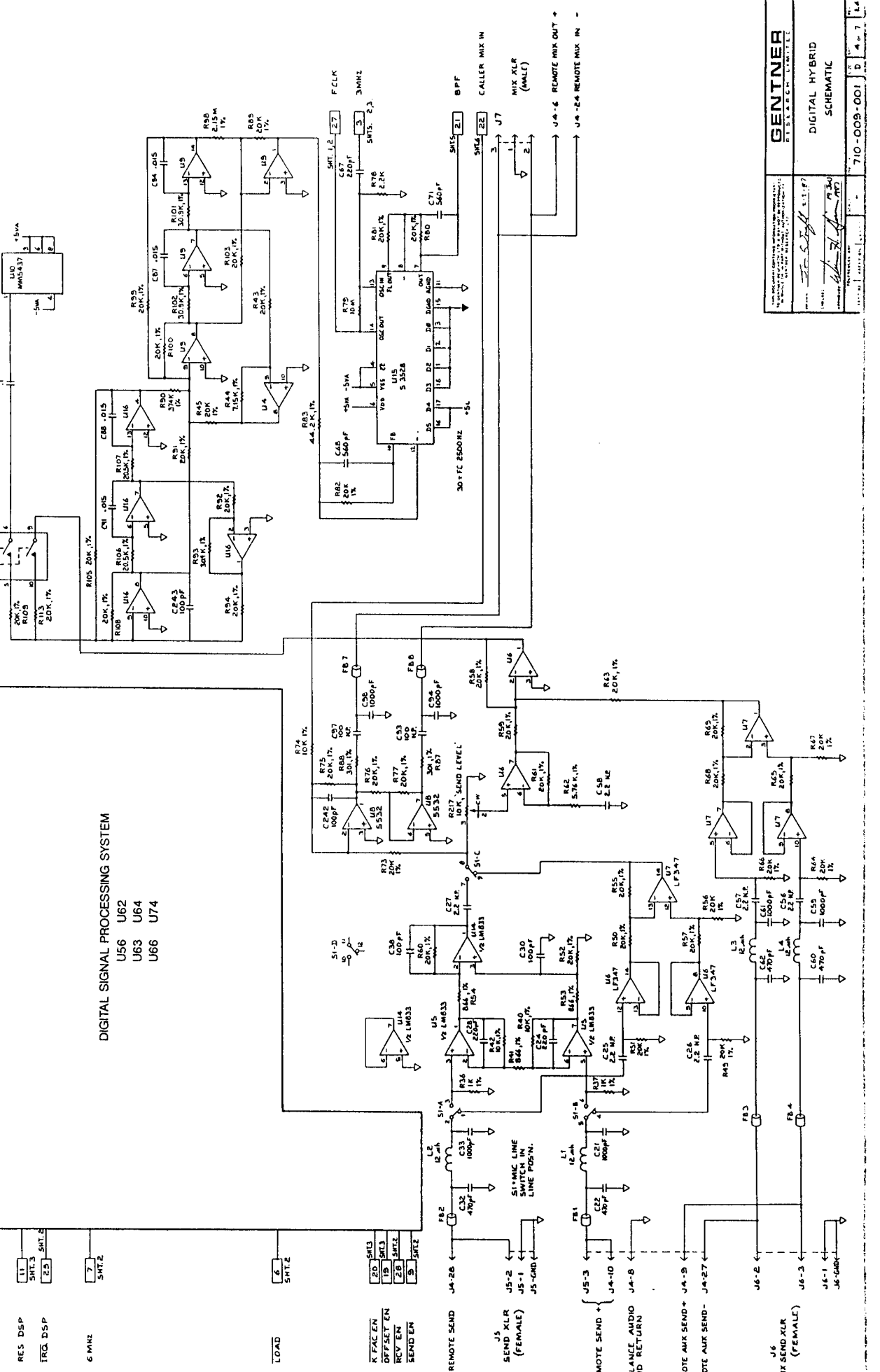

DIGITAL SIGNAL PROCESSING SYSTEM
 U56 U62
 U63 U64
 U66 U74

GENTNER RESEARCH LIMITED	
DIGITAL HYBRID SCHEMATIC	
DATE	10/15/03
DESIGNED BY	W. J. B.
CHECKED BY	W. J. B.
APPROVED BY	W. J. B.
REV	1
710-009-001 D 4-7	

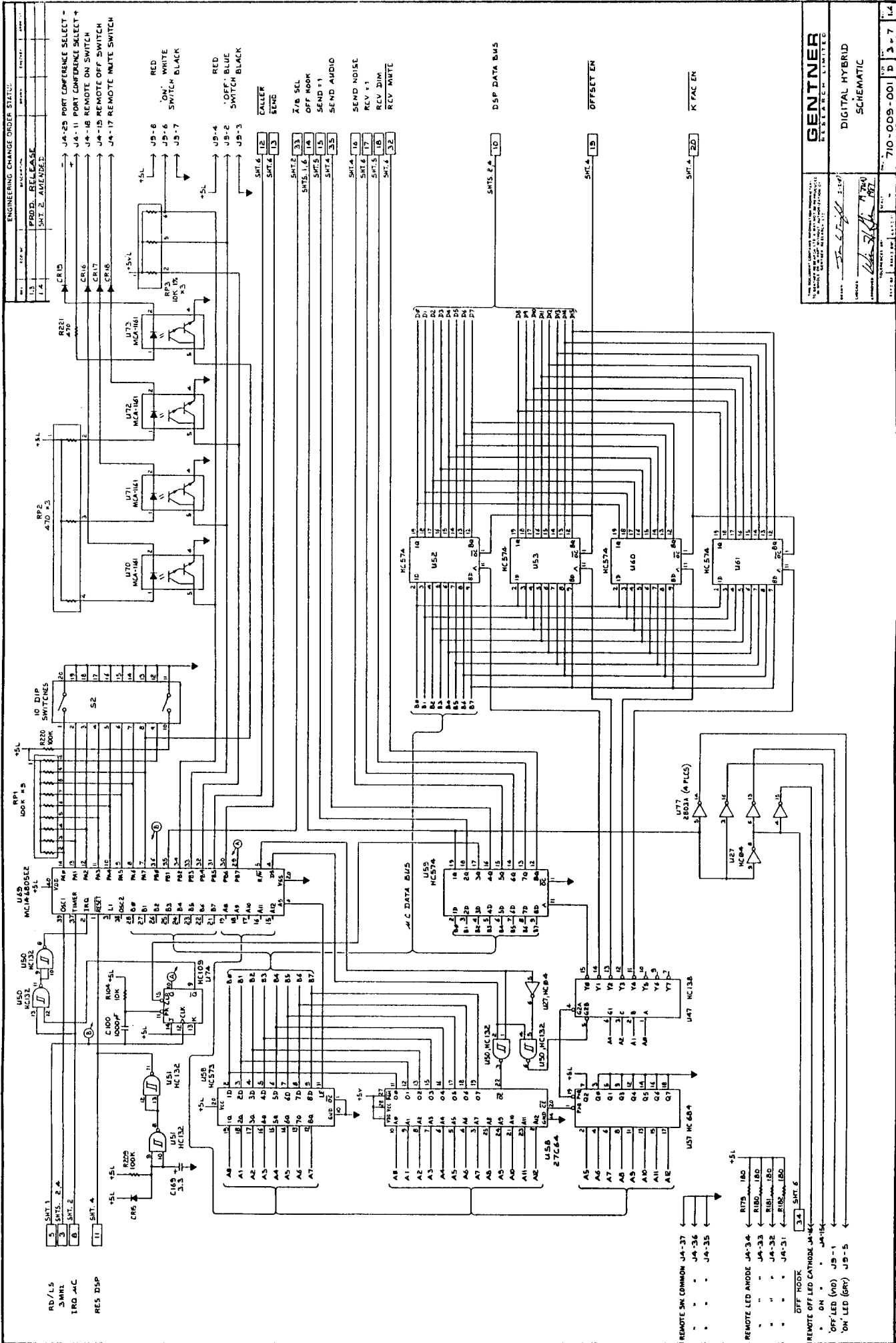

ENGINEERING CHANGE ORDER STATUS

REV.	DATE	DESCRIPTION	BY	CHKD.
1.3				
1.4		PROD. RELEASE SMT 2 AMENDED		

- JA-29 PORT CONFERENCE SELECT *
- JA-11 PORT CONFERENCE SELECT *
- JA-18 REMOTE ON SWITCH
- JA-15 REMOTE OFF SWITCH
- JA-17 REMOTE MUTE SWITCH

- RP2 470 #3
- RP1 100K AS
- U55 MC6805E2
- U52 MC574
- U53 MC574
- U56 MC574
- U57 MC574
- U58 MC574
- U71 MCA1161
- U72 MCA1161
- U73 MCA1161
- U74 MCA1161
- U75 MCA1161
- U76 MCA1161
- U77 2803A (4 PLS)
- U87 MC138

- CALLER SENSE
- X/O SEL
- OFF HOOK
- SEND #1
- SEND AUDIO
- SEND NOISE
- RCV #1
- RCV DIM
- RCV MUTE
- DSP DATA BUS
- OFFSET EN
- R PAC EN

GENTNER
RESEARCH LIMITED

DIGITAL HYBRID
SCHEMATIC

710-009-001 P 3 of 14

1.1	PROJ. RELEASE
1.2	ISSUED FOR FAB
1.3	ISSUED FOR ASSEMBLY
1.4	ISSUED FOR TESTING

START CONV.

3.0 SMT.2

2 SMT.1

1 SMT.1

1 SMT.1

1 SMT.1

1 SMT.1

1 SMT.1

1 SMT.1

1 SMT.1

1 SMT.1

1 SMT.1

1 SMT.1

1 SMT.1

1 SMT.1

1 SMT.1

1 SMT.1

1 SMT.1

1 SMT.1

1 SMT.1

1 SMT.1

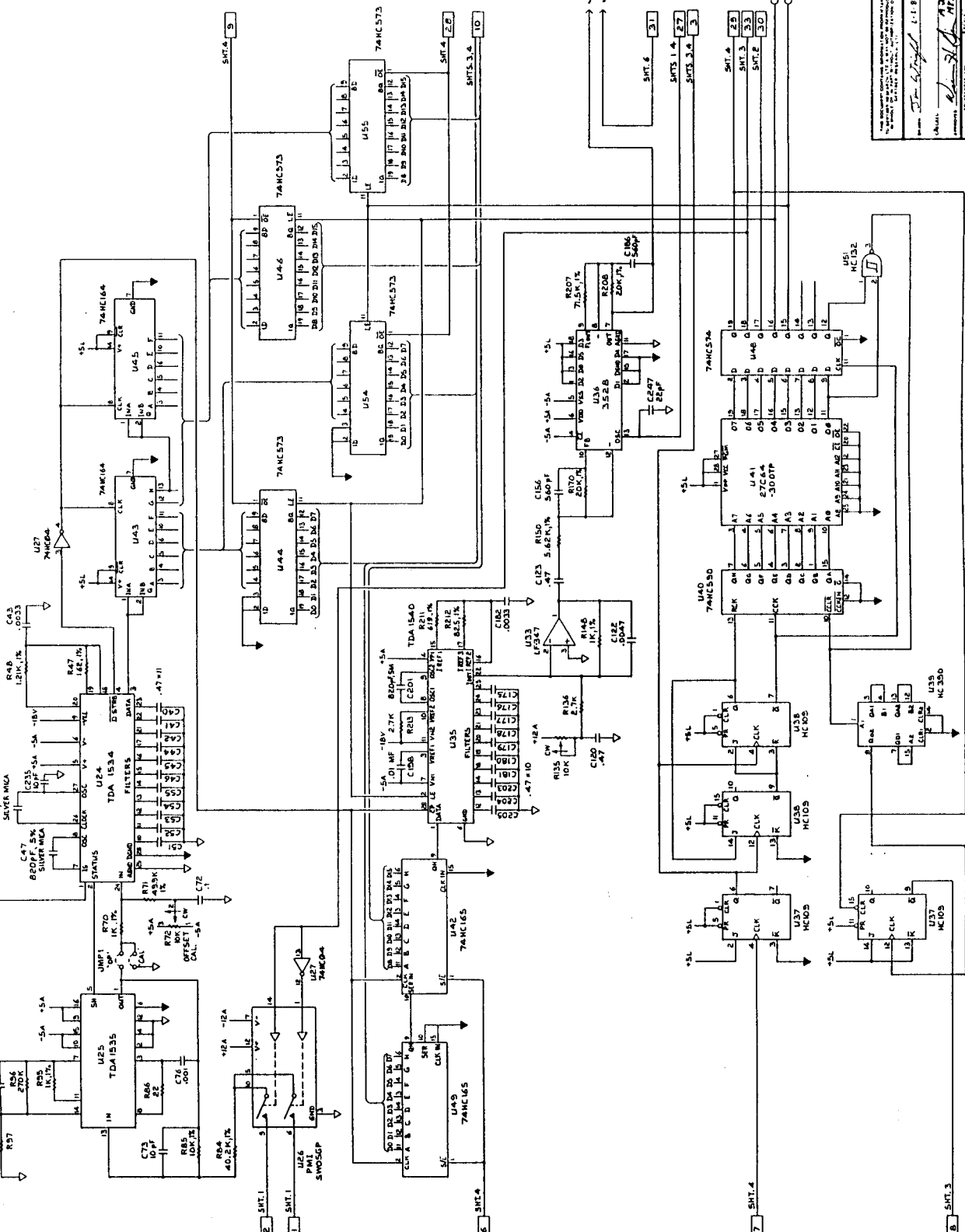

GENTNER
RESEARCH LIMITED

DIGITAL HYBRID
SCHEMATIC

710-009-001 D E-7 1.4

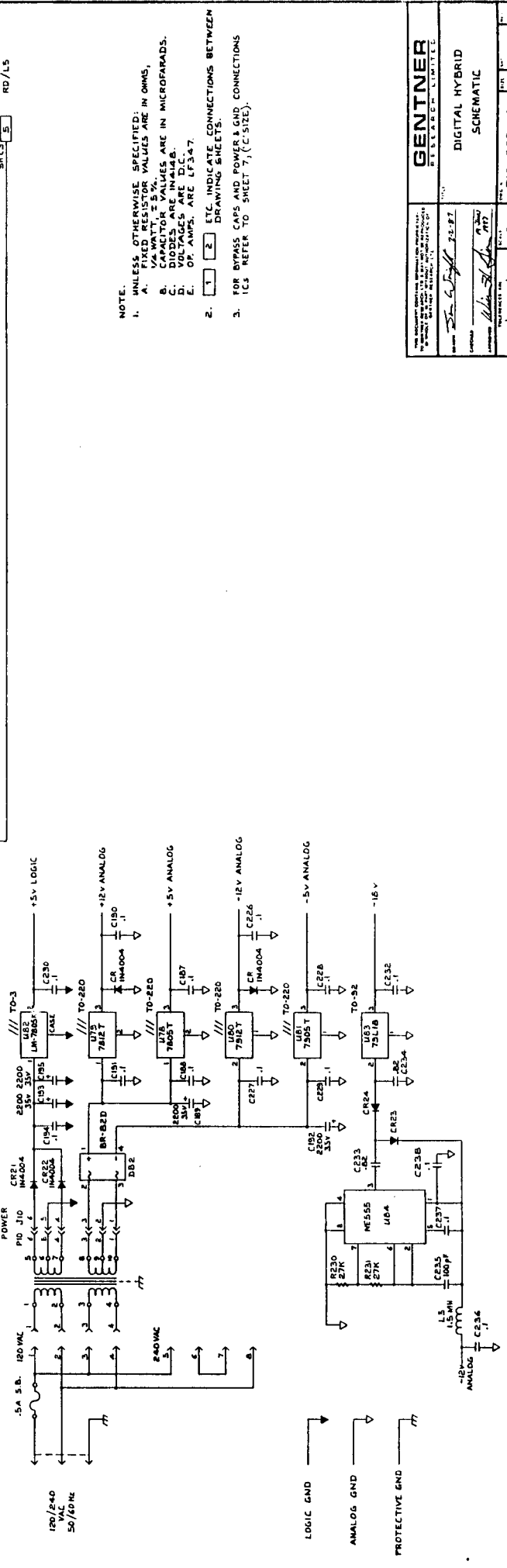
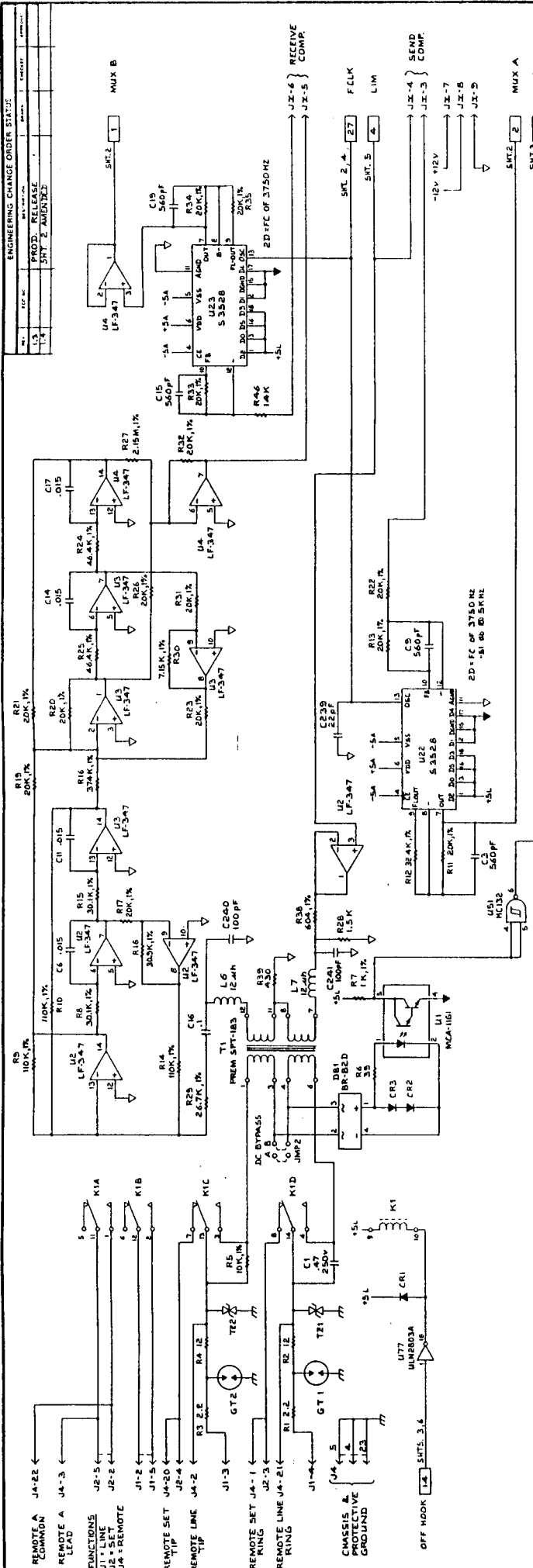

NOTE:
 1. UNLESS OTHERWISE SPECIFIED:
 A. FIXED RESISTOR VALUES ARE IN OHMS,
 1/4 WATT, 5%
 B. ALL POTENTIOMETER VALUES ARE IN MICROFARADS.
 C. DIODES ARE 1N4004 UNLESS OTHERWISE SPECIFIED.
 D. VOLTAGES ARE D.C.
 E. OP. AMPS. ARE LF347.
 2. 1 2 ETC. INDICATE CONNECTIONS BETWEEN DRAWING SHEETS.
 3. FOR BYPASS CAPS AND POWER & GND. CONNECTIONS ICS REFER TO SHEET 7, (C/SIZE).