

# Converge™ Pro

White Paper

**ClearOne**





©2007 ClearOne Communications, Inc. All rights reserved. No part of this document may be reproduced in any form or by any means without written permission from ClearOne Communications, Inc. Printed in the United States of America. ClearOne Communications reserves specific privileges. Information in this document is subject to change without notice.

## Converge™ Pro

White Paper

ClearOne Part Number 803-151-880 Rev 1.5

# TABLE OF CONTENTS

CHAPTER 1: Introduction .....	1
Overview.....	1
Converge Pro 880 Product Description .....	3
Converge Pro 840T Product Description .....	4
Converge Pro 8i Product Description .....	5
Converge Pro TH20 Product Description .....	6
Converge Console Description .....	7
Controls and Connections .....	8
CHAPTER 2: Echo and Noise Cancellation .....	13
Echo Cancellation .....	13
Noise Cancellation .....	14
CHAPTER 3: Processing Blocks.....	15
Filters.....	15
CHAPTER 4: Inputs and Outputs .....	17
Mic\Line inputs .....	17
Line Inputs .....	18
Outputs .....	18
CHAPTER 5: Automatic Mic Mixing .....	19
Intelligible, Reliable Audio .....	19
Microphone Parameters and Modes .....	20
CHAPTER 6: Audio Routing .....	23
Matrix Mixing .....	23
CHAPTER 7: System Control .....	27
CHAPTER 8: Applications .....	31
Distance Learning .....	31
Courtroom .....	31
Boardroom .....	32
APPENDIX: Specifications .....	33
Converge Pro 880 Specifications .....	33
Converge Pro 840T Specifications .....	34
Converge Pro 8i Specifications .....	36
Converge Pro TH20 Specifications .....	38
Glossary .....	41

# CHAPTER 1: INTRODUCTION

## OVERVIEW

The Converge Pro™ product line provides a complete sound system for collaboration, presentation, distance communications and any other multimedia audio event.

The Converge Pro audio system is extremely flexible allowing it to be used in many different applications. It provides superior audio quality for this wide range of applications. This is the result of combining ClearOne's proprietary Distributed Echo Cancellation and ClearOne's advanced adaptive algorithms with powerful audio digital signal processing for automatic microphone mixing, signal routing, equalization, automatic level control, compression and other audio processing functions. The Converge Pro system uses a rapid configuration user interface for system setup, minimizing the time it takes to get a system up and operational. The Converge Pro is the heart of custom installed audio system.

For ease of use, Converge Pro systems facilitate local and remote PC setup, control, and diagnostics; compatibility with ClearOne Table Top controller and integration with popular control systems.

## New Converge Pro Enhancements

- Next generation ClearOne® Distributed Echo Cancellation®—four, eight, or twelve input digital signal processors (DSPs) improve full-duplex performance and remove echo in the most difficult acoustic environments.
- New PTT (Push-to-Talk) microphone compatibility provides greater design and configuration flexibility.
- New EC (Echo Cancellation) Reference Summing uses multiple signals for echo cancellation without requiring a dedicated output.
- Advanced noise cancellation reduces background noise caused by fans, HVAC systems, and other relatively constant background noise sources.
- Signal processing with user-configurable filters (including all pass, low pass, high pass, low shelving, high shelving, and parametric), delay, and compression. ClearOne®'s unparalleled processing power enables you to use all of these features simultaneously in any combination, allowing you to deliver optimized audio configurations.
- Enhanced expansion bus capabilities—connect up to eight Converge Pro units together and use up to 64 microphones and 16 phone lines for a single site.
- Increased distance between units—up to 200 feet/60.96 meters.
- Graphical, user-configurable routing matrix allows you to route any input channel to any output, processing, or fader channel (or combination thereof) on any Converge™ Pro unit, or across the expansion bus.
- Front panel control of mute and gain for all input and output and output channels.
- ClearOne®'s DSP (Digital Signal Processing) technology ensures crystal-clear audio.

## AEC (Acoustical Echo Cancellation) Enhancements

- Smoothing filters to reduce artifacts
- AEC (Acoustic Echo Cancellation) freezing
- Pre-AEC bypass channels
- Improved AEC adaption and noise suppression algorithms
- Automated Push-to-Talk microphone mode
- Gain and gating control tracking
- Cross-point gain adjustments

- Four fader channels
- Microphone preamp gain control
- 7 dB coarse gain and .5 dB fine gain increments for improved microphone gain matching
- AGC (Automatic Gain Control) algorithm
- ALC (Automatic Level Control) algorithm

## Telephone Hybrid Enhancements (840T and TH20)

- Custom telephone line settings for international teleconferencing and in-country localization
- Type I & Type II auto-sensing telephone interface (U.S./E.U.)
- International impedance matching
- Improved TEC (Telco Echo Cancellation) with 31 millisecond tail time
- Continual TEC adaptation to telephone line conditions
- ClearEffect™ wideband audio emulation algorithm
- Digital anti-alias filter minimizes CO switching noise and hum
- ALC (Automatic Level Control) on telco receive channel
- Improved call management and processing
- Adjustable dial tone, DTMF attenuation
- Off-hook DTMF generation
- Robust dial tone detection
- Ringer selection
- Caller ID
- Touch-tone dialing capability (40 character dial string)
- Analog telephone line compatibility
- 10 W speaker amplifier (840T only)

## Product Line Features:

- Remote and local setup and diagnostics from any PC
- 32 programmable presets for instant configuration changes
- Connect multiple Converge Pro 880/8i/840Ts to create a single system.
- Logic ports for external control and status monitoring
- Distributed Echo Cancellation on each mic input for greater echo cancellation flexibility and effectiveness
- Noise cancellation on each mic input to reduce unwanted ambient noise
- Advanced automatic mixer functions that minimize false activation of microphones including: Adaptive Ambient, First Microphone Priority and PA Adaptive Mode. Up to eight automatic mixer microphone groups can operate across a single system
- Telephone hybrid uses digital signal processing (DSP) to separate the transmit and receive audio, eliminating distortion, weak signals, and feedback as well as continually filters low and high frequency noise to provide pure sound.
- Increased distance (up to 200 feet) between each connected Converge Pro unit
- Fully configurable matrix which allows you to route any input to any output or combination of outputs
- Create up to 255 macros per unit

## CONVERGE PRO 880 PRODUCT DESCRIPTION

### Converge Pro 880 Overview

The successor to the industry-leading XAP® 800. As the flagship product in ClearOne's next-generation Converge Pro professional audio conferencing product line, the 880 delivers rich functionality with improved audio performance, enhanced management, and simplified configuration for audio conferencing and sound reinforcement applications.

### The Converge Pro 880 Features:

#### **Advanced Conferencing Feature Set**

- Next-generation Acoustic Echo Cancellation
  - » Improved duplex performance
  - » Push-to-talk microphone compatibility
- Next-generation Noise Cancellation
  - » Adaptive modeling to room ambient noise conditions
- Increased resolution on Microphone Preamp stage
  - » 0-56 dB in 7 dB increments
- Pre-AEC routing for sound reinforcement applications
  - » Maximum of 4 millisecond processing delay
- Management Improvements
  - » Integrated Ethernet and USB connections
  - » SNMP and HTML remote management agents
  - » Web-based, customizable user and control consoles
  - » Event scheduler
  - » Diagnostic console
- Simplified Configuration Software
  - » Drag & drop A/V and channel objects
  - » Selectable Console views—Unit, Matrix, and Channel
- Expanded serial command set

#### **Superior Audio Performance**

- Next-generation Distributed Echo Cancellation® on every mic input
- First-mic priority delivers clear audio to the far end
- 20 Hz-22 kHz bandwidth for full-range audio response
- ALC & AGC keep participants' audio balanced and consistent

#### **Configuration Flexibility**

- Scalable – link multiple Converge Pro units (880, 840T, 8i, TH20) for extensive microphone coverage and up to 16 phone lines
- Enhanced expansion bus, featuring 12 mix-minus audio buses for routing between units
- Eight mic gating groups (four internal & four global) allow separation of mics into individual mixer gating groups for greater configuration flexibility
- 32 presets can be executed on-the-fly without disturbing other ongoing preset operations
- 255 Macros for customized audio control/configuration with single command execution

#### **Conferencing Capability**

Link with multiple Converge Pro units for a total of up to 16 telephone lines and 64 mic inputs

## CONVERGE PRO 840T PRODUCT DESCRIPTION

### Converge Pro 840T Overview

The successor to the industry-leading XAP® 400. Leveraging the rich functionality of the flagship Converge™ Pro 880, the new 840T includes a built-in telephone interface and power amplifier for standalone conferencing applications. It also provides expansion capability with other Converge™ Pro mixers for complex installations.

### Converge Pro 840T Features

#### **Advanced Conferencing Feature Set**

- Next-generation Acoustic Echo Cancellation
  - » Improved duplex performance
  - » Push-to-talk microphone compatibility
- Next-generation Noise Cancellation
  - » Adaptive modeling to room ambient noise conditions
- Increased resolution on Microphone Preamp stage
  - » 0-56 dB in 7 dB increments
- Pre-AEC routing for sound reinforcement applications
  - » Maximum of 4 millisecond processing delay
- Management Improvements
  - » Integrated Ethernet and USB connections
  - » SNMP and HTML remote management agents
  - » Web-based, customizable user and control consoles
  - » Event scheduler
  - » Diagnostic console
- Simplified Configuration Software
  - » Drag & drop A/V and channel objects
  - » Selectable Console views—Unit, Matrix, and Channel
- Expanded serial command set

#### **Superior Audio Performance**

- Next-generation Distributed Echo Cancellation® on every mic input
- First-mic priority delivers clear audio to the far end
- 20 Hz-22 kHz bandwidth for full-range audio response
- ALC & AGC keep participants' audio balanced and consistent

#### **Configuration Flexibility**

- Scalable – link multiple Converge Pro units (880, 840T, 8i, TH20) for extensive microphone coverage and up to 16 phone lines
- Enhanced expansion bus, featuring 12 mix-minus audio buses for routing between units
- Eight mic gating groups (four internal & four global) allow separation of mics into individual mixer gating groups for greater configuration flexibility
- 32 presets can be executed on-the-fly without disturbing other ongoing preset operations
- 255 Macros for customized audio control/configuration with single command execution

#### **Conferencing Capability**

- Link with multiple Converge Pro units for a total of up to 16 telephone lines and 64 mic inputs



## CONVERGE PRO 8i PRODUCT DESCRIPTION

### Converge Pro 8i Overview

An input-only expansion box for the Converge Pro platform. The 8i delivers new economical configuration flexibility. It can be added to 880 or 840T systems for additional mic and line inputs, allowing customers to match the number of inputs and outputs required for audio conferencing and sound reinforcement installations.

### Converge Pro 8i Features

#### **Advanced Conferencing Feature Set**

- Economical Mic/Line only mixer for large configurations where additional output channels are not required
- Next-generation Acoustic Echo Cancellation
  - » Improved duplex performance
  - » Push-to-talk microphone compatibility
- Next-generation Noise Cancellation
  - » Adaptive modeling to room ambient noise conditions
- Increased resolution on Microphone Preamp stage
  - » 0-56 dB in 7 dB increments
- Pre-AEC routing for sound reinforcement applications
  - » Maximum of 4 millisecond processing delay
- Management Improvements
  - » Integrated Ethernet and USB connections
  - » SNMP and HTML remote management agents
  - » Web-based, customizable user and control consoles
  - » Event scheduler
  - » Diagnostic console
- Simplified Configuration Software
  - » Drag & drop A/V and channel objects
  - » Selectable Console views—Unit, Matrix, and Channel
- Expanded serial command set

#### **Superior Audio Performance**

- Next-generation Distributed Echo Cancellation® on every mic input
- First-mic priority delivers clear audio to the far end
- 20 Hz-22 kHz bandwidth for full-range audio response
- ALC & AGC keep participants' audio balanced and consistent

#### **Configuration Flexibility**

- Scalable – link multiple Converge Pro units (880, 840T, 8i, TH20) for extensive microphone coverage and up to 16 phone lines
- Enhanced expansion bus, featuring 12 mix-minus audio buses for routing between units
- Eight mic gating groups (four internal & four global) allow separation of mics into individual mixer gating groups for greater configuration flexibility
- 32 presets can be executed on-the-fly without disturbing other ongoing preset operations
- 255 Macros for customized audio control/configuration with single command execution

#### **Conferencing Capability**

- Link with multiple Converge Pro units for a total of up to 16 telephone lines and 64 mic inputs

## CONVERGE PRO TH20 PRODUCT DESCRIPTION

### Converge Pro TH20 Overview

The successor to the industry-leading XAP® TH2. The TH20 enables conference call functionality for Converge™ Pro installations with its single telephone line connection. Up to 16 units can be linked for greatly expanded conferencing capability. It also adds two line-level inputs and outputs for increased system capacity.

### Converge Pro TH20 Features

#### **Advanced Telephone Feature Set**

- Signal Processing Improvements
  - » Telephone noise cancellation on RX channel
  - » ClearEffect speech enhancement
  - » Automatic level control on RX channel
  - » Caller ID
  - » Selectable ringers
- Increased I/O capabilities
  - » Two line level inputs and two line-level outputs
  - » Audio Expansion bus (E-bus)
- Management Improvements
  - » Integrated Ethernet and USB connections
  - » SNMP and HTML remote management agents
  - » Web-based, customizable user and control consoles
  - » Event scheduler
  - » Diagnostic console
- Simplified Configuration Software
  - » Drag & drop A/V and channel objects
  - » Selectable Console views—Unit, Matrix, and Channel
- Expanded serial command set

#### **Configuration Flexibility**

- Scalable – link multiple Converge Pro units (880, 840T, 8i, TH20) for extensive microphone coverage and up to 16 phone lines
- Enhanced expansion bus, featuring 12 mix-minus audio buses for routing between units
- Eight mic gating groups (four internal & four global) allow separation of mics into individual mixer gating groups for greater configuration flexibility
- 32 presets can be executed on-the-fly without disturbing other ongoing preset operations
- 255 Macros for customized audio control/configuration with single command execution

#### **Conferencing Capability**

- Link with multiple Converge Pro units for a total of up to 16 telephone lines and 64 mic inputs

## CONVERGE CONSOLE DESCRIPTION

The Converge Console software provides a powerful, intuitive interface for configuring and controlling your Converge Pro system. While you can use LCD Programming for some simple configuration tasks, you must use Console for the advanced configuration tasks required to customize Converge Pro units for your application.

### Rapid System Configuration

Console provides powerful Drag and Drop Configuration capabilities that allow you to quickly configure Converge Pro devices and perform advanced system configuration tasks.

### AV Devices

AV Devices are pre-configured input or output channel settings that can be dragged from a menu of devices and dropped on to a channel to rapidly configure the channel. AV devices represent devices like microphones, DVD players, video conferencing systems, amplifiers, etc. ClearOne provides numerous pre-configured AV devices, with settings that optimize the performance of the device for a typical room. Beside ClearOne provided pre-configured AV devices, custom AV devices can be created by the user of Converge Console.

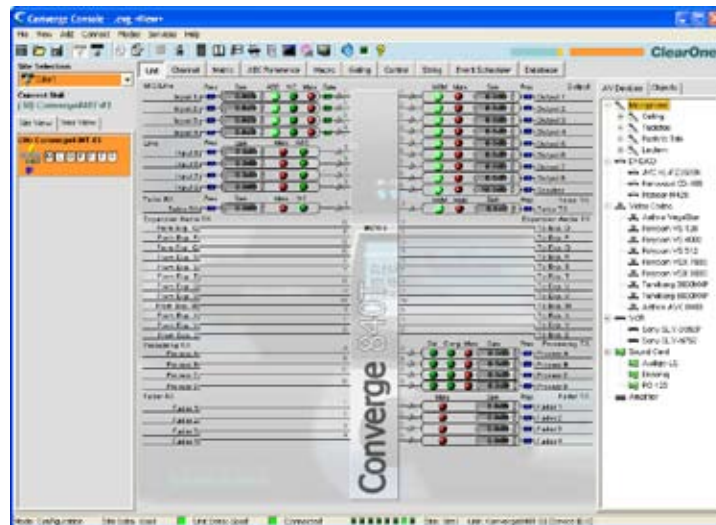

### Object Database

In addition to using AV devices, Converge Console allows you to create, save and apply, Channel, Matrix, Control, Macro, and Preset Objects. Saved objects can be imported/exported between different computers. Types of objects are described below.

#### Channel Objects

Channel objects allow you to save customized Channel configurations into the Database and reuse them. This enables you to instantly re-configure the entire channel and to rapidly configure additional Converge Pro units using drag and drop configuration.

#### Matrix Objects

Matrix objects allow you to save customized matrix configurations into the database and reuse them. This enables you to instantly re-configure the entire matrix to accommodate changes in conferencing or venue configuration requirements, and to rapidly configure additional Converge Pro units using drag and drop configuration.

**Control Objects**

Control objects allow you to save control port objects into the database. After saving the control port object, it appears in the object pane of Console. To apply a control object after saving it to the database, drag it from the object pane and drop it onto the control/status portion of the Control Tab screen.

**Macro Objects**

Macro objects allow you to save macros into the database and reuse them. After saving a macro as an object, it appears in the object pane of Console. To use a macro object, drag it from the Objects Pane and drop it onto the Macro Command List portion of the Macro Tab screen.

**Preset Objects**

Preset objects allow you to save preset configurations into the Database and reuse them. This enables you to instantly apply preset changes, and to rapidly configure additional Converge Pro units using drag and drop configuration.

## CONTROLS AND CONNECTIONS

Refer to the following diagrams for Converge Pro front panel controls and and the back panel connections.

### Converge Pro Front Panels

*Converge Pro 880 Front Panel*

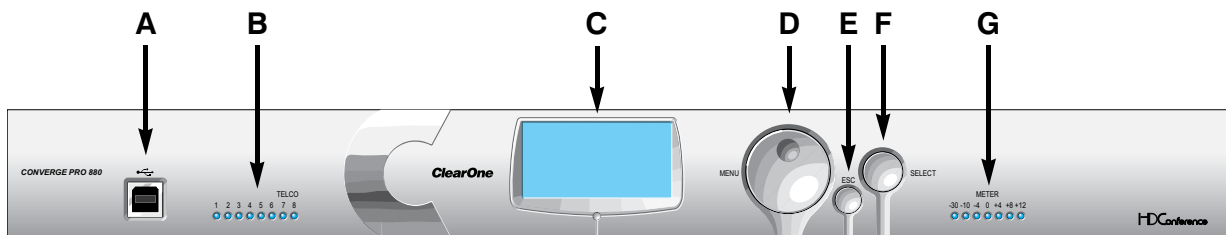

*Converge Pro 840T Front Panel*

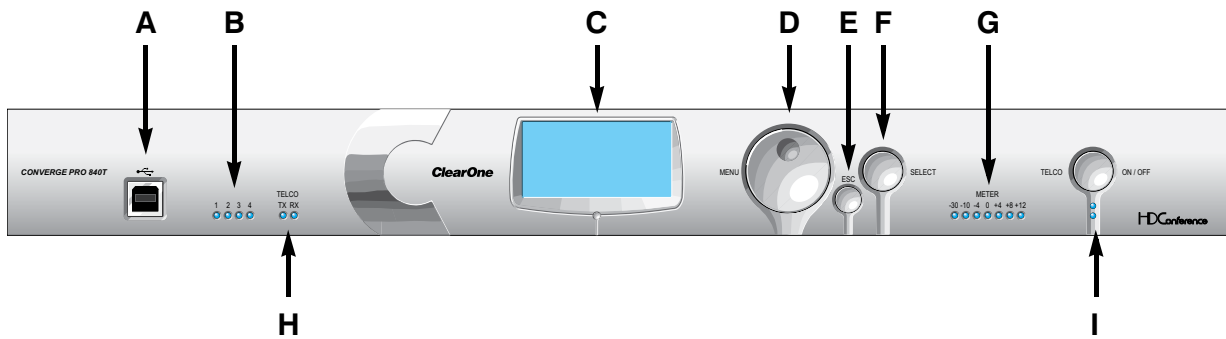

*Converge Pro 8i Front Panel*

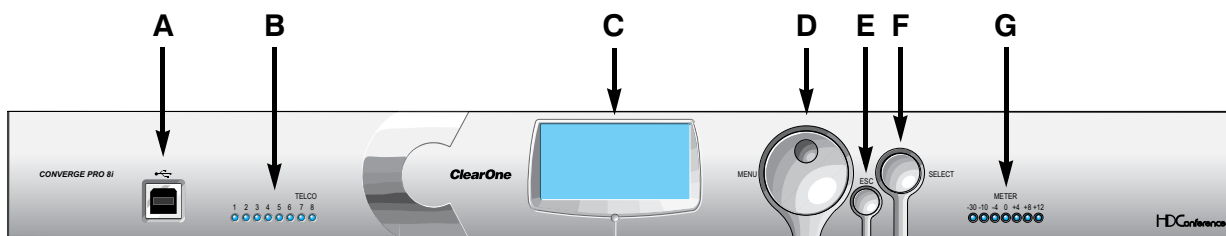

*Converge Pro TH20 Front Panel*

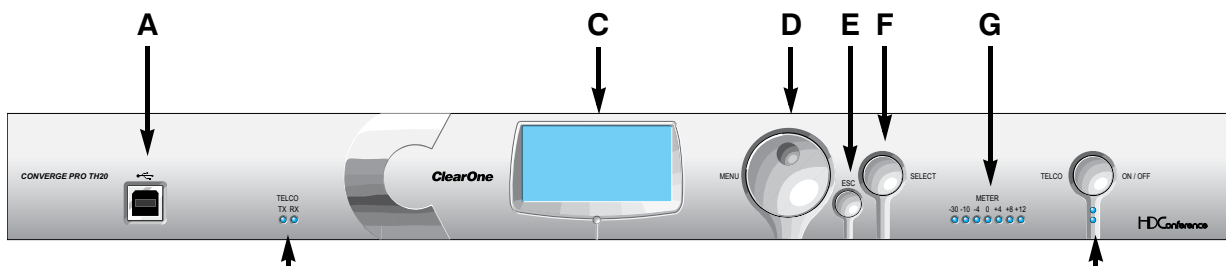

## Converge Pro Front Panel Control Descriptions

- A. USB Type B Port:** Provides convenient front panel connectivity for laptops, computers, and other USB devices.
- B. Microphone-On LEDs:** Indicate microphone gate and mute status.
- C. LCD Display:** The LCD display shows model number, unit name, IP address, programming menu pages, menu options, configuration settings, and parameter values.
- D. Menu Dial:** The Menu Dial navigates the Converge Pro LCD programming menu and enables you to select and modify configuration settings.
- E. ESC Button:** The ESC button returns you to the previous screen on the LCD display.
- F. Select Button:** The Select button displays the Converge Pro LCD programming menu and selects the highlighted menu option.
- G. LED Bar Meter:** The LED bar meter displays the audio level of a selected input, output, processing, or fader channel. Default meters: 880-Output 12, 840T-Output 8, TH20-Telco Tx, 8i-Mic 1.
- H. Telco TX/RX LEDs:** The Telco TX/RX LEDs display transmit, receive, and mute status of the connected telephone line (840T and TH20 only).
- I. Telco On/Off Button & LEDs:** The Telco On/Off button connects and disconnects the connected telephone line. The LEDs indicate the connection status (840T and TH20 only).

## Converge Pro Back Panels

### Converge Pro 880 Back Panel

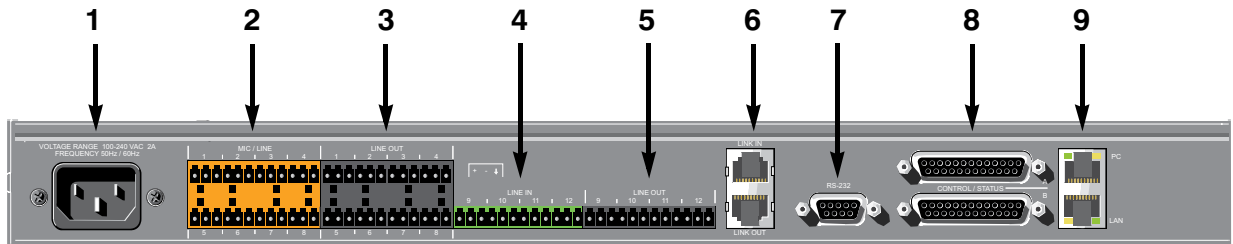

### Converge Pro 840T Back Panel

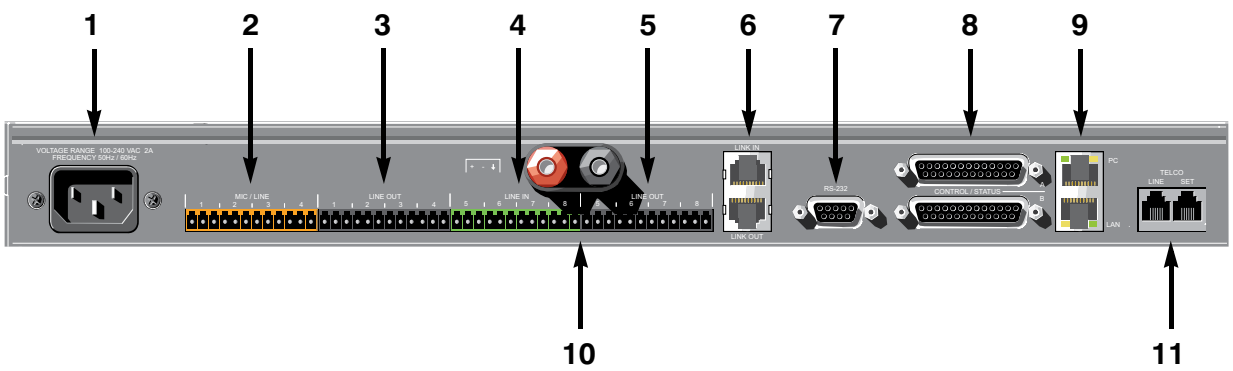

### Converge Pro 8i Back Panel

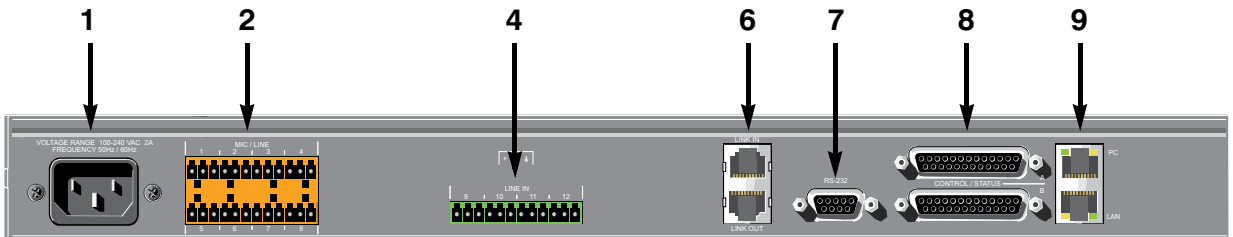

### Converge Pro TH20 Back Panel

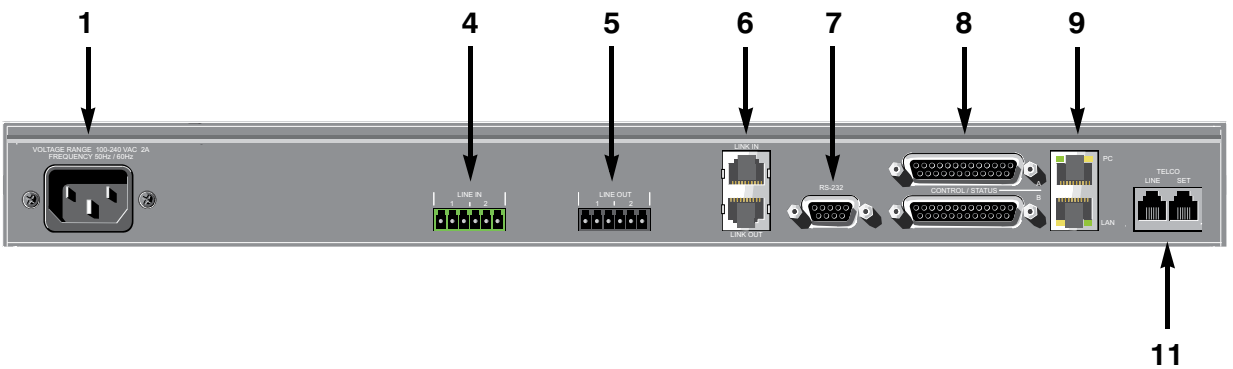

## Converge Pro Back Panel Descriptions

1. **AC Power:** IEC connector, 100–240VAC auto-adjusting, 50/60Hz.
2. **Mic/Line Inputs:** Mini-terminal push-on block connector for any combination of microphone and/or line level inputs. (Converge Pro 880: 8 inputs. Converge Pro 840T: 4 inputs. Converge Pro 8i: 8 inputs. Converge Pro TH20: 0 inputs.)
3. **Line Outputs:** Mini-terminal push-on block connector for line-level outputs. (Converge Pro 880 and 840T only.)
4. **Line Inputs:** Mini-terminal push-on block connector for line-level inputs only. (Converge Pro 880: 4 inputs. Converge Pro 840T: 4 inputs. Converge Pro 8i: 4 inputs. Converge Pro TH20: 2 inputs.)
5. **Line Outputs:** Mini-terminal push-on block connector for line-level outputs (Converge Pro 880, 840T, and TH20 only).
6. **Link In and Link Out Ports:** Two RJ-45 E-bus (expansion bus) connectors used to connect multiple Converge Pro units together to create a site. You can connect up to eight Converge Pro 840T/880/8i units, up to 16 Converge Pro TH20 units, or any combination thereof, where the total number of microphone inputs does not exceed 64. Maximum cable length is 200 feet using Category 5 unshielded twisted pair (UTP) cable.



**WARNING:** Use the **Link In** and **Link Out** ports with Converge Pro Devices ONLY. Connecting ANY other devices to the Link In and Link Out ports, including ClearOne XAP products or Power Over Ethernet (POE) devices, will result in severe equipment damage.

7. **RS-232 Serial Port:** Female DB9 connector for connecting to a laptop, computer, or remote control serial devices (such as AMX and Crestron).
- NOTE:** Converge Console software cannot connect via the RS-232 port; use USB or Ethernet.
8. **Control/Status A and B Ports:** Two female DB25 connectors used for General Purpose Input/Output (GPIO) interactions between Converge Pro devices and external control devices (such as wall switches and push-to-talk microphones). This enables external devices and controller software to access the Converge Pro command set, including common functions such as volume control, muting, room combining, and preset changes.
  9. **PC and LAN Ethernet Ports:** Two RJ-45 10/100 auto-sensing Ethernet ports. The LAN Ethernet port is used to connect Converge Pro devices to a network. The PC Ethernet port provides a pass-through network connection for use with a standard (not crossover) patch cable. The LEDs adjacent to each port indicate connection status and packet traffic activity.
  10. **Speaker Posts:** Two post/banana plug connectors used to connect an external speaker (4Ω - 16Ω). An internal 10 W power amplifier eliminates the need for an external power amplifier. (Converge Pro 840T only.)
  11. **Telco Line and Set Ports:** Two RJ-11 connectors telephone ports. The Telco Line port is used to connect an analog telephone line to Converge Pro devices. The Telco Set port provides a pass-through connection for telephone handsets. (Converge Pro 840T and TH20 only.)

**NOTE:** The Set port is not active (available for use) when the hybrid is off-hook.



## CHAPTER 2: ECHO AND NOISE CANCELLATION

### ECHO CANCELLATION

Acoustic echo is a significant challenge to overcome in most any teleconferencing applications. Acoustic echo can compromise a teleconference because it impairs participants' abilities to understand others and communicate with one another.

Acoustic echo occurs when microphones pick up loudspeaker audio and return it to the originating teleconference site. This echo can cause a conference participant to stop speaking while listening to the echo.

An acoustic echo canceller removes echo by sampling audio from the remote site, and preventing it from being returned to the originating site.

For the best clarity, every site in the conference should use echo cancellation.

There are several factors that contribute to poor echo cancellation. These include:

- Poor room acoustics
- High reverberation
- High noise
- Rapidly changing acoustical environment
- Wireless or other moving microphones
- Poor microphone/speaker placement
- Automatic mic mixers that are not properly configured to work with an echo canceller
- Other audio devices such as audio processors and user gain controls that change the acoustic gain to which the echo canceller must adapt.

**Figure 2.1** shows how an echo canceller cancels echo in a room. Audio from the distant room is sampled and used as a reference signal.

When far-end audio is picked up by the microphone (acoustic echo), the acoustic echo canceller adapts and eliminates the echo.

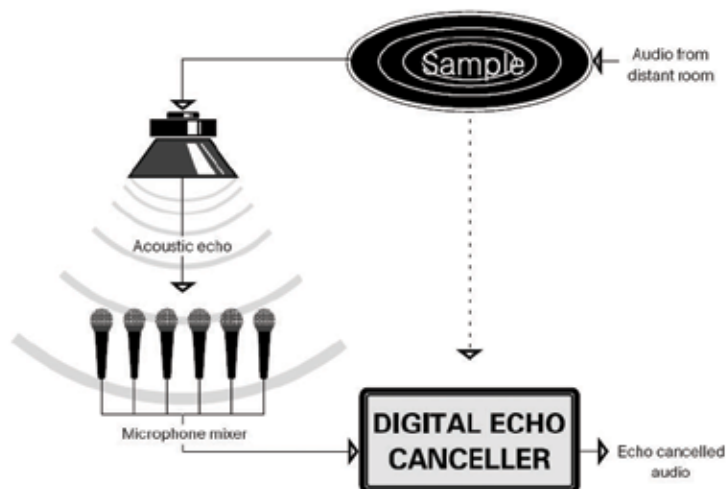

**Figure 2.1**

The Converge Pro 880's Distributed Echo Cancellation places an echo canceller on each mic input for dramatically improved echo cancellation (**Figure 2.2**)

In this example, audio from a distant room is sampled. This audio is a reference for each echo canceller on every mic. When sampled audio (acoustic echo) is detected by the echo canceller, the echo is eliminated.

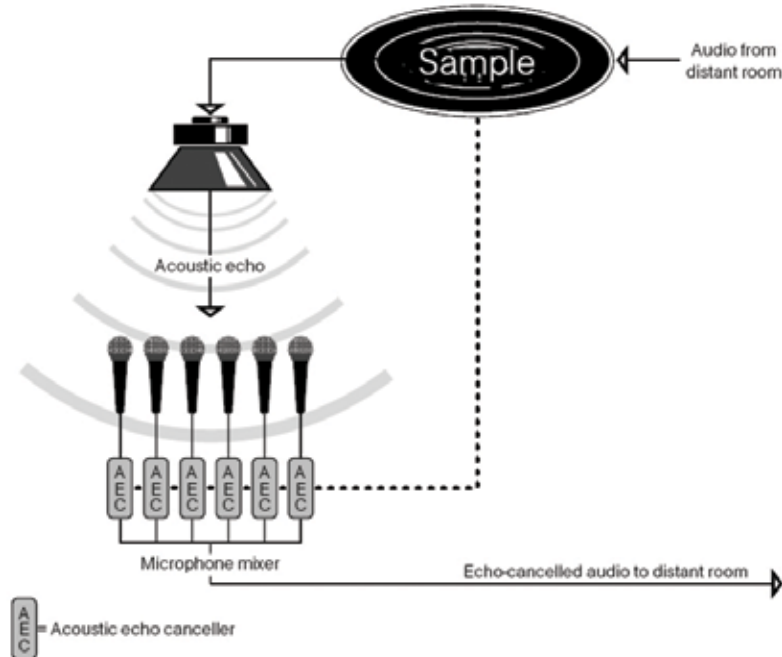

Figure 2.2

## NOISE CANCELLATION

ClearOne's Converge Pro systems feature a revolutionary new algorithm that actively eliminates background noise within the vocal range on each mic input. Unlike other noise cancelling devices, Converge Pro does not simply gate audio off when a mic input drops below a specified level. ClearOne's noise cancellation actively separates and attenuates ambient noise from the speech signal, leaving speech audio virtually untouched.

Noise not only interferes with human communication, it hampers system components (i.e., DSPs, amplifier power, loudspeaker bandwidth), thereby decreasing a system's responsiveness. By reducing signals unassociated with human speech, Converge Pro ensures the entire system sounds clearer and is much more efficient and responsive.

Converge Pros' noise canceller is an excellent complement to its acoustic echo canceller. By reducing ambient noise, which can cause the echo canceller to diverge, it ensures the echo canceller provides the most accurate echo cancellation.

## CHAPTER 3: PROCESSING BLOCKS

The Converge Pro 880 and 8i features the power of eight processing blocks, which are dedicated signal processing resources that can be applied to any mic or line input routed to it. The Converge 840T features four processing blocks. Within each processing block, compression, delay, gain adjustments, and up to 15 different filters may be applied to any mic/line input, or combination of inputs routed to the block. Each input also has four assignable filters for shaping the input audio signal.

### FILTERS

#### Feedback

Perhaps the most common (and the most annoying) problem for professional sound engineers is feedback. Feedback is often a high, piercing tone caused when mics pick up resonant frequency and amplify it through the sound system, where it is picked up again by the microphones and amplified.

In addition to being painful to hear, feedback can cause amplifiers to clip, which can destroy drivers and loudspeaker components. While most feedback can be controlled through proper microphone placement, resonant frequencies can be attenuated using filters such as parametric equalizers.

Low frequency feedback isn't necessarily audible, but it decreases the system's power and responsiveness. By attenuating the low-end frequencies not needed for vocals, with low cut /high pass filters, the Converge Pro operates more efficiently.

#### Converge Pro Filters

The Converge Pro provides customizable filters for feedback control. These filters can boost or attenuate certain audio frequencies, compensate for poor acoustics, and fine-tune your sound system. Some filters, such as pass filters, allow you to select a range of audio frequencies above or below a given point and attenuate them, while others allow you to attenuate specific frequencies. Filters are also excellent for use in cancelling frequency ranges that cannot be transmitted through telephone lines, thereby freeing up system resources.

#### Filters

The Converge Pro 880, 8i and Converge Pro 840T feature the following filters:

- **All Pass.** A filter that provides only phase shift or phase delay without significantly changing the magnitude of the signal. Useful in custom crossovers designed to compensate for loudspeaker driver deficiencies.
- **CD Horn Equalizer.** A constant directivity horn driver has an inherent 6dB/octave high frequency roll-off. This filter produces a 6dB/octave boost to compensate. The CD horn equalizer is implemented using a high shelving filter. The level control is fixed at +12dB.
- **High Pass.** This filter allows frequencies above a designated frequency to pass while attenuating those below it. This filter attenuates low, rumbling noises like those captured by a microphone when placed on a stage, table, or in a microphone stand.
- **High Shelving.** This filter boosts or attenuates frequencies above a designated frequency while leaving those below it unaffected. The transition between the spectrum above and below the designated frequency occurs at a fixed 6dB/octave rate. When boosted, it enhances the higher, more intelligible aspects of the vocal range. When cut, it eliminates extraneous sibilance (like a constant “sssssss” noise).

- **Low Pass.** Allows frequencies below a designated frequency to pass while attenuating those above it.
- **Low Shelving.** Boosts or attenuates frequencies below a designated frequency, leaving those above it unaffected. The transition between the spectrum above and below the designated frequency occurs at a fixed 6dB/octave rate. Excellent for enhancing the low-end range of a signal.
- **Notch Filter.** A band-stop filter that can remove a select range of frequencies. Commonly used for removing specific resonant frequencies from a system.
- **Parametric Equalizer.** A multi-band variable equalizer that allows the user to define the amplitude of the filter, shift the center frequency of the filter, and control how wide the range is to which the equalizer is applied.

Filters for the Converge Pro 880 and Converge Pro 840T are configured in Converge Console software.

## Crossovers

The Converge Pro 880/840T features a crossover that combines high-pass and low-pass filters to divide a full-range signal into separate frequency ranges. These ranges can then be sent to amplifiers and loudspeakers optimized for producing those respective frequency ranges

For example, the bottom end of a frequency range might be defined as 400Hz and lower. This signal might then be heavily compressed and sent to bass bins and woofers powered by amplifiers. The midrange (say, 400Hz to 5kHz) can be sent to full-range loudspeakers. The high end (say, 5kHz and above) can be directed to smaller amplifiers and associated tweeters, piezos, horns, etc.

Converge Pro audio conferencing devices include three types of crossovers: Butterworth, Bessel, and Linkwitz-Riley. Each crossover is characterized by the steepness of their roll-off slopes (the rate of attenuation outside their passbands).

Crossovers in the Converge Pro are created by assigning the appropriate type of high-pass filter in a processing block with the complementary low-pass filter in a separate processing block.

- **Bessel Crossover.** Utilizes a low-pass filter design with a linear phase response (or maximally flat phase response), and a monotonic decreasing passband amplitude response (it rolls off at DC and continues throughout the passband). Linear phase response (a linear phase shift vs. a frequency producing a straight line) results in constant time delay for all frequencies within the passband. The linear phase shift reproduces a near-perfect step response (with no overshoot or ringing resulting from a sudden transition between signal levels). The drawback is a sluggish roll-off rate. For example, for the same circuit complexity, the response for a Butterworth crossover rolls off nearly three times as rapidly.
- **Butterworth Crossover (1 pole).** A low-pass filter design characterized by a maximally flat magnitude response (i.e., no amplitude ripple in the passband).
- **Linkwitz-Riley (LR-4) Crossover (2 poles).** The 4th-order (24dB/octave slope) Linkwitz-Riley (LR-4) design represents a vast improvement over the previous 3rd-order (18dB/octave) Butterworth standard. It consists of a cascaded 2nd-order Butterworth low-pass filter, and is considered the de facto standard for professional active audio crossovers.

Converge Pro has an intuitive filter display, which shows the aggregate filter response for a particular processing block. This display can overlay the filter responses of other processing blocks, which is useful in designing active crossovers. The aggregate phase response of the processing block can also be shown superimposed on the filter response curve.

## CHAPTER 4: INPUTS AND OUTPUTS

### MIC/LINE INPUTS

Balanced audio is input at the rear panel Phoenix connector. Mic or line level is selected and phantom power is provided (if required). Converge Pro devices convert input audio from analog to digital for processing by the DSP engine. Once converted to digital, audio level is controlled. This function, along with all other functions, can be adjusted via local or remote external control interfaces, or PCs connected via USB, network, or RS-232 port. This provides real-time volume control, muting, etc. Minimum and maximum levels can also be set to limit the range of gain to suit audio requirements.

The acoustic echo canceller and noise canceller is the first option in the audio signal flow. Here, you set the echo cancellation reference, non-linear processing (optional), and meters reflecting echo cancellation activity. You can also enable the noise canceller and depth of cancellation. A second audio path exists that takes the input signal before the AEC and noise cancellation stages and routes it to the matrix via a second set of filters, AGC, ALC and automixing functions. The settings of the filters, AGC, ALC and automixing functions mirror the setting of the primary audio path with echo cancellation and noise cancellation. The pre-AEC channel provides an audio signal that has not been altered in any way by the AEC, NLP or noise cancellation and has a lower latency, less than 4ms. (Figure 4.1)

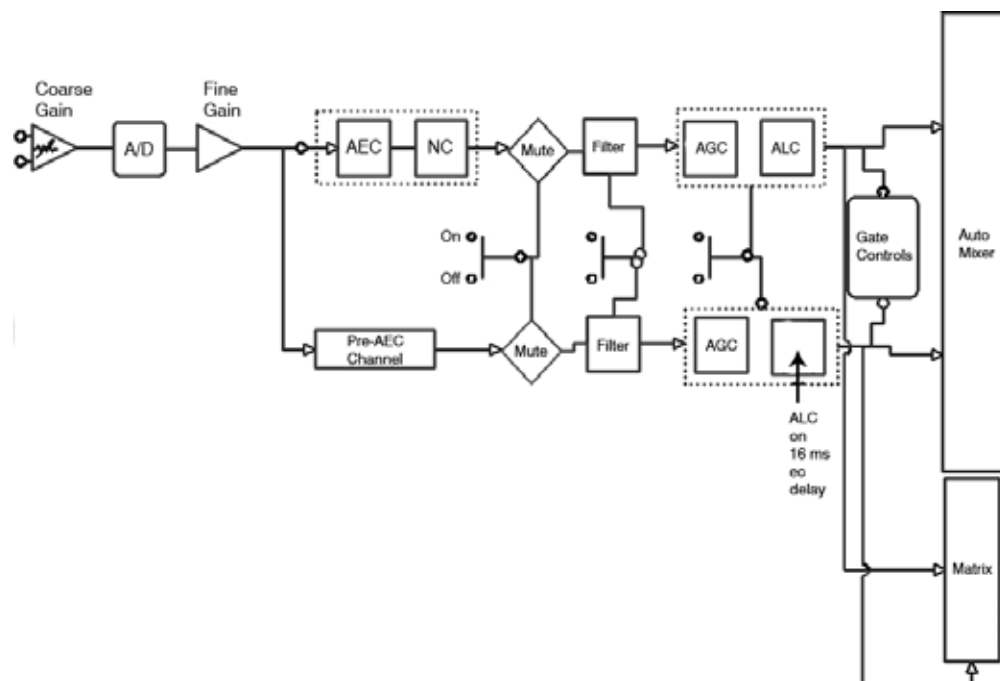

Figure 4.1

Next, four configurable filters can each be set individually or in any combination. Each may be activated to equalize different microphones to sound similar, filter out unwanted hum, etc. You can increase or decrease each band up to 15dB, in increments of .5dB for each input.

The next option is AGC and ALC. ALC automatically adjusts microphone levels to ensure participants' voices are heard at a consistent level regardless of whether people are speaking loudly or softly. ALC is simply turned on or off. AGC also provides a consistent level but unlike the ALC, the operation parameters can be adjusted. AGC and ALC cannot be operated simultaneously.

The next stage is the channel mute. After the channel mute stage, non-gated audio is applied to the routing matrix for outputs that need direct audio. The final stage (automixing) determines how the audio is directed into the post-

gating input to the routing matrix. Each input can be set for a variety of automixing functions, including activation settings, chairman override, and adaptive ambient mode. These functions determine when, how, and why an individual microphone gates on or off.

- **Microphone Activation.** There are two modes of mic activation that can be selected on a per-input basis: autogate and manual gate on/off. In auto-gate mode, the input channel is voice activated, based on the programmed automixing system parameters. In manual gate mode, the mic is activated by manually switching it on or off and allowing the input to contribute to automixing parameters.
- **Chairman Override (On or Off).** Each gated input may be Misc or other audio from another room chairman override input. This feature adds the input to the chairman override group and, when Chairman override off inputs within the same group that are not chairman override enabled.
- **Adaptive Ambient (On or Off).** When enabled, the ambient level used to calculate gating is based on the room's actual noise floor, integrated over time, as measured by the input in the room. In the off mode, the ambient level (used to This Audio does not Activate a mic channel on the Converge PRO) is manually set by the integrator.

## LINE INPUTS

Figure 4.2 shows line level inputs. These line level inputs can be level controlled, muted, and gain controlled through Converge Console. All of these functions operate identically to the mic inputs.

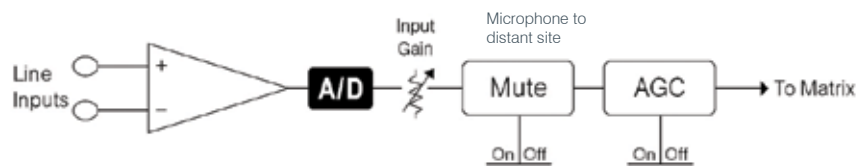

Figure 4.2

## OUTPUTS

All line outputs are identical, as shown in Figure 4.3. Three functions are associated with each output: gain control, mute, and NOM (number of open mics). Gain control allows you to set the output level. The min/max controls allow you to set minimum and maximum gain levels that the user will be limited to. The mute function essentially turns the volume off.

Activation of NOM places this output in a mode where, as more microphones routed to this output are gated on (either by auto gate or manual gate), the total overall output gain will remain constant. This reduces feedback.

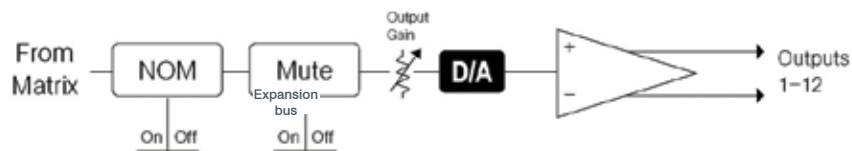

Figure 4.3

## CHAPTER 5: AUTOMATIC MIC MIXING

### INTELLIGIBLE, RELIABLE AUDIO

Systems that produce intelligible and reliable audio are key to facilitating effective communication. A quality conferencing system meets the following objectives:

- The audio must be transparent. Users should not have to think about the audio.
- The audio must not fatigue the users. Distorted, noisy audio will cause users to break off discussions before a natural conclusion occurs. It will also fatigue the users, and potentially reducing their effectiveness.
- Since 10% of our population is hearing impaired, the audio system must be capable of producing effective results for all users.
- The audio system must be reliable.

Automatic microphone mixing is key to producing intelligible, reliable conferencing audio. By turning the level of microphones up when a person speaks, an automatic microphone mixer will reduce the pickup of reverberation and noise—the two major culprits in making voice communications difficult. The more an automatic mixer can prevent false activation of microphones by signals other than local talkers, the higher the clarity of the audio.

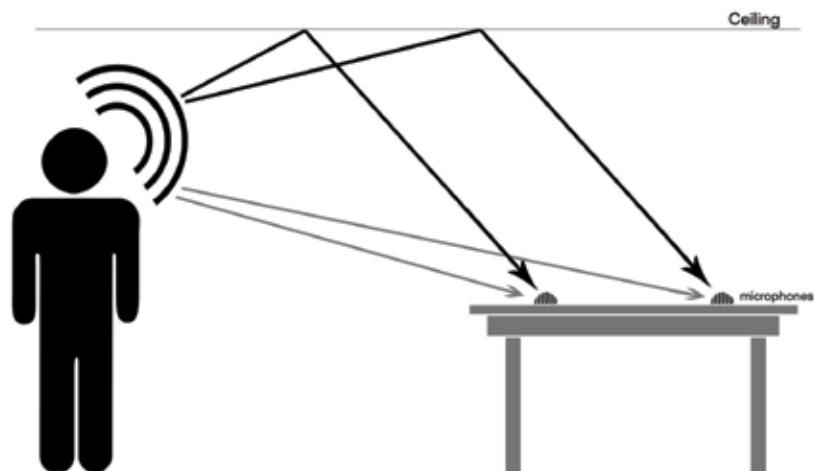

**Figure 5.1**

In Figure 5.1, direct audio from a person's voice is picked up by several microphones connected to a microphone mixer that has all microphones on at all times. Direct and reflected audio (reverberation) is picked up by all the microphones. In addition, the reflected audio will have a variety of delays, depending on how far it has traveled in the room. If the reflected audio is high enough in level, participants will have a difficult time understanding the audio. When people hear reverberated audio, their initial response is to turn up the volume. In other words, increased noise and reverberation hurts audio intelligibility and increases listener fatigue.

There are several strategies that can reduce reverberation and noise:

- Keep microphones close to the participants
- Activate only those microphones where voice audio is present
- Use directional microphones
- Acoustically treat the room to reduce reverberation and noise
- Eliminate or reduce the source of noise

The Converge Pro 880/840T devices are designed to implement automatic microphone mixing, which increases

audio intelligibility by reducing reverberation and noise. Converge Pro implements its mixing function completely in the digital domain, which greatly increases auto mixing precision. All audio is routed through the Converge Pro (both microphone and speaker audio), which means the Converge Pro can more accurately make microphone activation decisions.

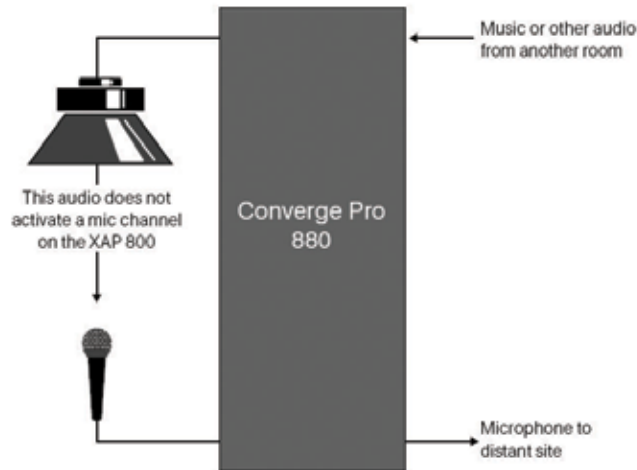

Figure 5.2

For example, when PA Adaptive is enabled, audio from another source (such as conference audio from another room) is amplified through the speakers in the room. Typically, an automixer would activate at least one microphone, as if that audio were a voice in the room. This false activation will not occur with Converge Pro (see Figure 5.2) because the unit can identify loudspeaker audio.

## MICROPHONE PARAMETERS AND MODES

Converge Pro devices have a variety of automixing functions that are implemented on a per-channel basis and across the entire auto mixer. These functions are described on the following pages. Each Converge Pro device can have up to four separate automatic mixers working independently, and up to four independent global mixers across multiple units. In addition, more microphone channels can be added by linking Converge Pro units together to create a unified system. See Figure 5.3 below.

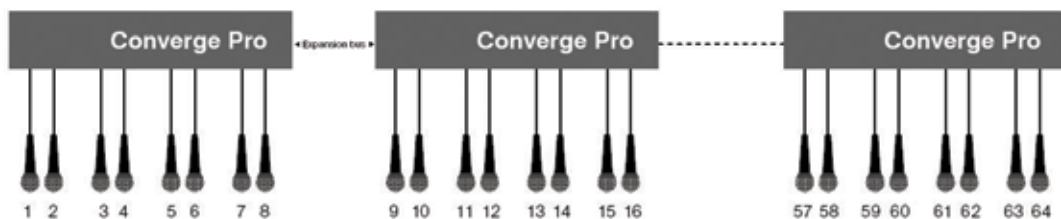

Figure 5.3

- **Chairman Override.** This provides gating priority for all microphones selected for the chairman override group. When a mic in this group gates on, all microphones within this group that are not chairman override enabled gate off.
- **PA Adaptive (On or Off).** PA Adaptive prevents the speakers from gating the mics on. Converge Pro can accurately determine when loudspeaker audio is present because it samples the signal a few milliseconds before it reaches the microphone.
- **Maximum Number of Microphones on (1-8 or Off).** This mode allows you to program how many



microphones (maximum) can be gated on simultaneously. Generally, there isn't a need for more than two or three people to speak at the same time.

- **First Mic Priority Mode (On or Off)**. This feature increases the audio level required to gate on additional microphones after the first mic gates on. This helps ensure that only one mic gates on when a person speaks.
- **Last Mic On/Mic1-8/Off**. Last Mic On leaves the last activated mic on until a new one is activated. Mic 1–8 mode reverts back to the mic you've selected for Mic 1–8 on when all other mics gate off. These features are useful to ensure the audio never goes completely away. Without it, participants might think that you have lost connection to the other room. You can set this parameter to Off.

The following are depicted in Figure 5.4 (below):

- **Gate Ratio Adjust (0 to 50dB)**. This specifies how much louder the audio level must be above the ambient level to gate on. For example, if the gate threshold is set at 35dB, it will take 35dB plus the gate ratio to activate the microphone. The ambient audio level can be specified, or the adaptive ambient mode can be turned on. In this case, as the ambient room level changes the audio level required to activate a microphone will also change, preventing background noise from falsely gating on microphones.
- **Off Attenuation (0 to 50dB)**. This sets how much a gated input is attenuated when it is not on.
- **Hold Time (.1 to 8.0 seconds)**. This sets the length of time the mic stays gated on after audio is no longer present (keeps the mic from gating off to pauses in speaking).
- **Decay Rate (slow, medium, fast)**. This sets how quickly the audio level attenuates to the Off Attenuation level after the hold time has expired.
- **Manual Ambient Level (0 to -80dB)**. This setting is relevant only if the adaptive ambient mode is disabled on the individual gated inputs. This ambient level is then used in conjunction with the gate threshold to determine whether or not the mic should turn on.

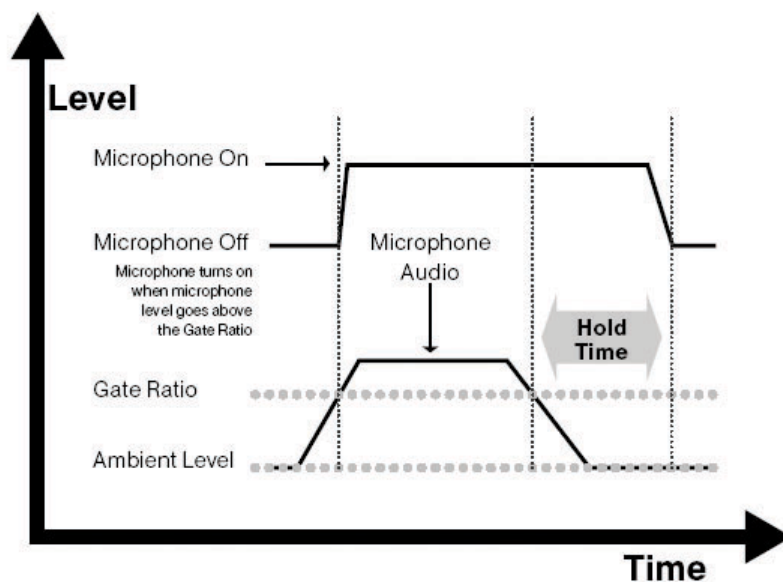

Figure 5.4

Parameter	Effect	Range	Description
Microphone Activation	Inputs 1–8	Auto gate, manual gate, on/off	Sets the method of microphone gating.
Chairman Override	Inputs 1–8	On/off	When a chairman override channel is gated on, all non-chairman inputs are gated off.
Adaptive Ambient mode	Inputs 1–8	On/off	Automatically sets the ambient audio level of the room averaged over time.
PA Adaptive mode	Inputs 1–8	On/off	This prevents mic channels from gating on to loudspeaker audio.
Maximum number of mics on	Mixer-wide	1–8 or off	Sets the maximum number of microphones allowed to be gated on at a time.
First Mic Priority mode	Mixer-wide	On/off	Increases the audio level required to gate on additional microphones after the first mic is gated on.
Last Mic mode	System-wide	Last, Mic 1–8, Off	Keeps the last gated microphone or one Mic 1–8 on when no mics are providing a gating input.
Gate Ratio Adjust	Inputs 1–8	0 to 50dB	Specifies how much louder above the ambient level the audio level must be to gate on.
Off Attenuation Adjust	Inputs 1–8	0 to 50dB	Sets how much the microphone will be attenuated when it is not gated.
Hold Time	Inputs 1–8	.1 to 8.0 seconds	Programs the amount of time it takes until the mic starts the off attenuation process.
Decay Rate	Inputs 1–8	Slow, medium, fast	Programs how quickly the audio level is attenuated once an input hold time has expired.
Manual Ambient Level	Inputs 1–8	0 to -80dB	Sets the ambient audio level when the adaptive ambient mode is off.
NOM/Constant Gain mode	Output sensitive	On/off	Maintains constant gain of a selected output. As more mics gate on, each mic is appropriately attenuated.

**Figure 5.5. Mixing parameters**

# CHAPTER 6: AUDIO ROUTING

## MATRIX MIXING

One of the most important functions of the Converge Pro audio conferencing solution is matrix routing of audio signals. Like all Converge Pro device functions, all routing is executed in the digital domain.

The Converge Pro audio matrix mixes, distributes and routes audio from any input to any output with level control at each cross point. The routing chart below (Figure 6.1) shows the default Converge Pro routing.

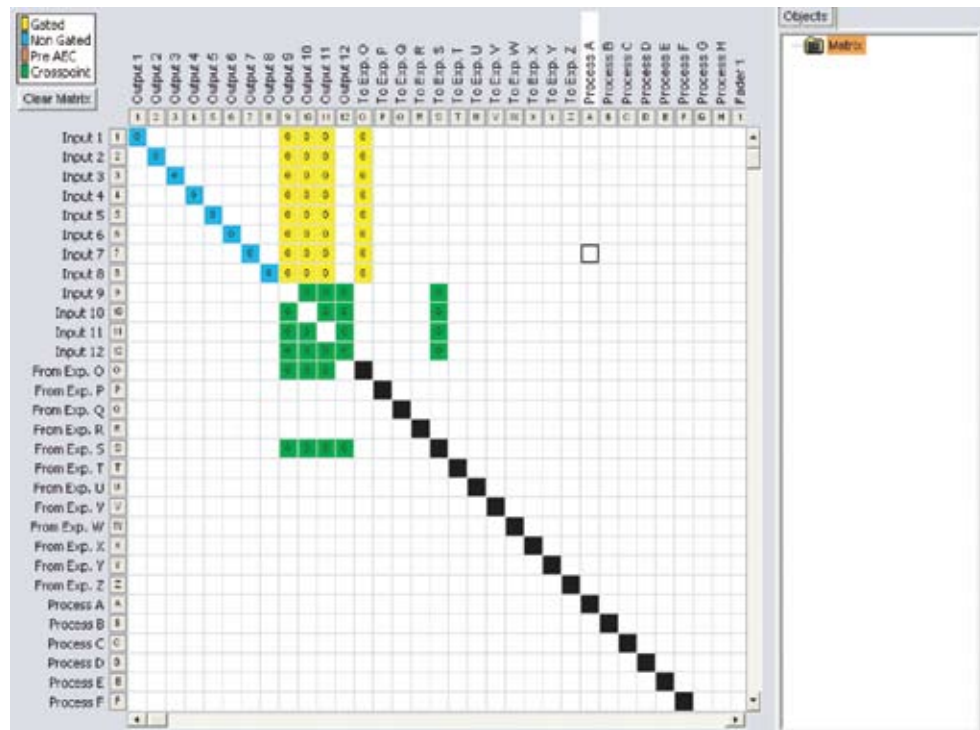

Figure 6.1

### Inputs

- **Mic/line inputs.** The mic/line inputs are located on the rear panel terminal blocks. Both gated, nongated, and gated pre-AEC inputs are provided for routing to the desired outputs.
- **Line Inputs.** These are line level inputs that appear on the rear panel terminal blocks. This is typically audio that comes from a CD player, video codec, or other auxiliary audio source.

### Outputs

- **Line Outputs.** Line level outputs are on the rear panel terminal blocks. Line outputs are typically used to route audio to recorders, power amplifiers, and other audio devices.

## Expansion Bus

The expansion bus is a digital mix-minus bus that is used to connect Converge Pro units. Audio placed on the bus for a particular unit is not fed back to that unit, but is available to all other units in the system. Audio on any linked Converge Pro unit can be placed on a bus channel, or taken off the bus and routed to any output of that unit. The Converge Pro system has 12 digital mix-minus buses with the following default programming.

- **O-R Buses.** By default, these four audio buses are the mic mix buses; they can communicate the NOM count across the network to other Converge Pro units. Otherwise, these buses are identical to buses S-Z.
- **S-Z Buses.** These eight buses are defaulted as auxiliary mix buses. They are used to route auxiliary audio, such as Converge Pro TH2 telephone audio, between units on the expansion bus. These buses are used as mic mix buses when NOM count is not required.

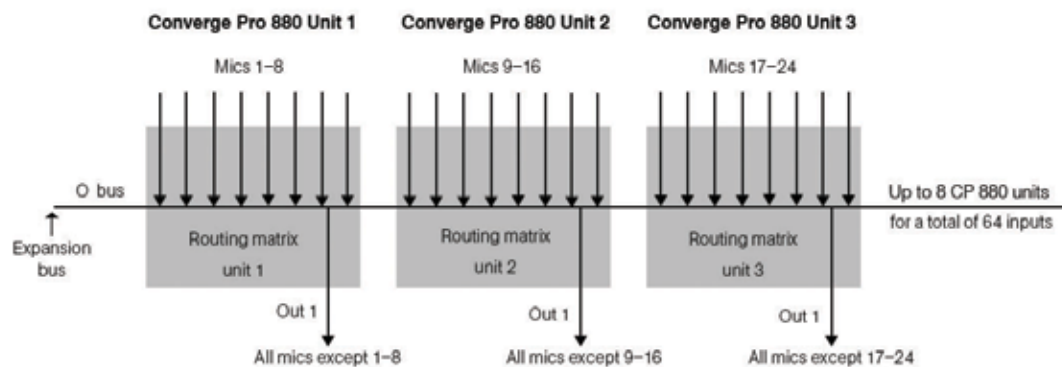

Figure 6.2

## Expansion Bus Reference Channels

Expansion bus reference channels are not shown on the matrix but are accessed when configuring the acoustic echo cancellers (AEC) or PA adaptive function on each microphone. The expansion bus reference channels provide a means to receive a reference input for PA Adaptive Mode and AEC from a different Converge Pro unit. For example, assume four Converge Pro units are linked together. Audio on the first unit is needed as a reference for mics on units 2, 3 and 4 so that the echo canceller cancels the appropriate audio. This is accomplished by selecting the appropriate PA Adaptive/EC reference from the first unit and placing it on an expansion bus reference and then configuring PA adaptive/EC references on the microphones of units 2, 3, and 4 to use the expansion bus reference.

## Assignable Signal Processing

There are eight assignable signal processing blocks in the Converge Pro 880/8i and four in the Converge Pro 840T. Each of these processing blocks include 15 audio filters of selectable types, compression, limiting and delay. Processing blocks “pre-mix” a number of input channels, process the “pre-mix” and then sends it to an output channel. This approach provides great flexibility in signal processing and level control. An assignable processing channel is a good way to create a “master” level control for a group or mix of audio signals. For example, if a room has both table-mounted microphones and wireless microphones, all the table microphones could be routed to an assignable signal processing channel, processed, and level-controlled as one combined group independent of the wireless microphones.

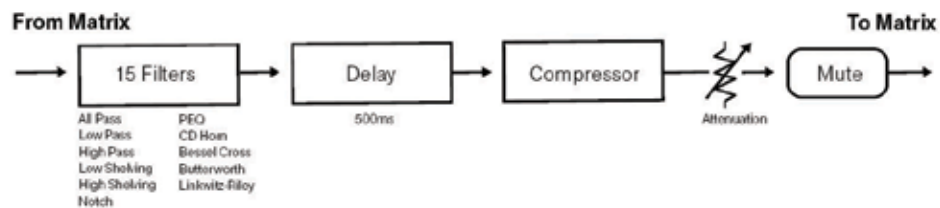

Figure 6.3

### Faders

There are four assignable fader channels in the Converge Pro 880/8i/840T. Faders are a way to “pre-mix” a number of input channels, process the “pre-mix”, and send it to an output. They are different from processing blocks in that they do not include filters, compression, limiting or delay.

## CHAPTER 7: SYSTEM CONTROL

Converge Pro units provide a variety of options for system control. You can create up to 32 presets and up to 255 macros to change room configurations or run a series of commands. Presets, macros, and commands can be executed using any of the following control options:

- Contact closures to Control/Status port A and B
- ClearOne Install Controller
- With a PC through the USB port
- With a PC over ethernet
- With a control system through expansion bus or RS-232 connections
- From the front panel (limited command set)
- With a PC using Internet Explorer to access the internal web host

### Presets

A preset is a group of routing and configuration settings. These settings are applied to the unit when the preset is executed. A good way to think of presets is to consider each preset as a room configuration option. You can create up to 32 presets which enables you to accommodate changing room requirements quickly and efficiently. Converge Pro presets are unique in the sense that they operate independently of other presets in the unit. When a preset is run, only the selected inputs/outputs are changed—all other settings in other presets remain unchanged and are not reset. This means you can change audio routing and configuration settings in a room without affecting settings in other rooms.

Presets can be executed in a variety of different ways including in Converge Console, the front panel of the Converge Pro unit, RS-232 external control devices, logic in/out, and contact closure, Ethernet or the ClearOne Tabletop Controller. You can also create macros which can run multiple presets. These options give you tremendous flexibility when designing your installations and are described in more detail in the Converge Pro Installation and Operation manual.

### Macros

Macros provide powerful options for controlling and operating your Converge Pro system. A macro can contain multiple commands that reference a single unit, or multiple units across the expansion bus. Each Converge Pro 880/8i and Converge Pro 840T is designed to support up to 255 macros, with an average of 150 command lines each. Macros are created in Converge Console using the Macro Recorder, which records your on-screen selections, or the Macro Editor, which allows you to directly create command lines. The Macro Editor is also used to edit macros created using the Macro Recorder. Macros greatly simplify the programming of control systems that are often used to control audiovisual systems and provide for standardized system control programming across many different projects and applications.

For more information on creating and using macros, consult the Converge Pro Installation and Operation manual.

### Control / Status Connections

Control/Status connections are provided on two DB-25 connectors. These connectors allow Converge Pro devices to control and be controlled by a wide variety of external devices, including relays, lamps, switches, and other equipment. **Figure 7.1** shows the Control/Status connector being used to perform room combining, level control and muting utilizing presets.

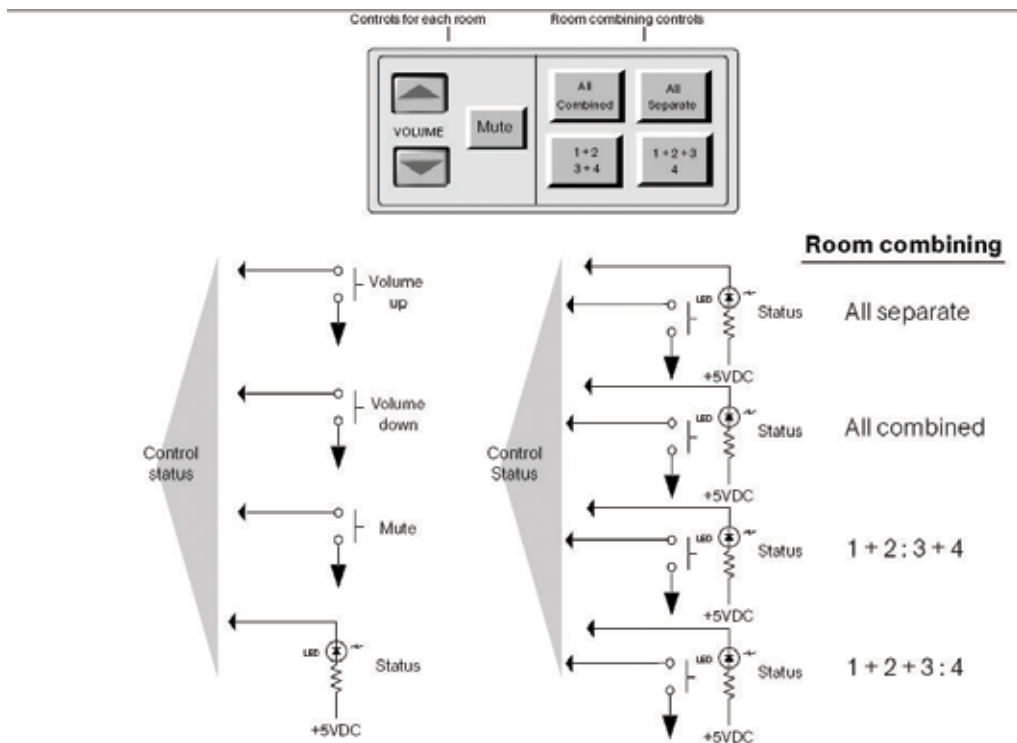

Figure 7.1

### ClearOne Control Devices

Operation of linked Converge Pro units can be done via the USB, RS-232 serial or Ethernet connections. Converge Console is used with the USB or Ethernet port. Audiovisual controllers can operate a Converge Pro system via Ethernet or RS-232.

### Front Panel

The Converge Pros' front panel is intuitive to operate, thanks to its simple and large interface LCD, menu buttons and scroll wheel, and a peak-level LED bar meter. Although most of Converge Pro features are programmed with Converge Console software, the front panel can be used for simple adjustments and meter monitoring. To prevent unauthorized changes, Converge Pro units can be password protected.

### Expansion Bus Audio Functions

The expansion bus allows up to eight Converge Pro 880/8i/840Ts and up to 16 Converge Pro TH20s to be controlled as if a single unit.

This digital mix-minus bus allows audio routing to and from any destination on the expansion bus. It contains 12 independent digital audio buses labeled O–Z, and four PA Adapt/echo cancellation reference buses. Each audio bus can route mic or line level inputs, in any combination, across the expansion bus. These buses are divided into two groups—O–R buses and S–Z buses—based on their capabilities and default settings.

- **O–R buses:** These four audio buses are defaulted as mic mix buses; they can communicate the NOM count across the network to other Converge Pros. Otherwise, these buses are identical to buses S–Z.

- **S–Z buses:** These eight buses are defaulted as auxiliary mix buses. They are used to route auxiliary audio, such as from a CD player, telephone interface, or video codec, to and from other units on the network. These buses are also used as mic mix buses when NOM count is not required.
- **PA Adapt/AEC Reference buses:** These buses provide a system-wide bus for input channels to receive a reference input for PA Adaptive Mode.

## Connecting To The Expansion Bus

Each Converge Pro comes standard with one expansion bus cable. The maximum (cable) distance allowed between any two Converge Pro units on an expansion bus network is 200 feet (60 meters). ClearOne recommends that category five twisted-pair (10BaseT) cable be used.



## CHAPTER 8: APPLICATIONS

The sophistication and adaptability of Converge Pro devices allows them to control and enhance many audio applications. Following are four applications where Converge Pro forms the centerpiece of a high-quality audio system.

### DISTANCE LEARNING

In a typical distance learning application, the primary source of audio comes from the instructor's wireless microphone. For phone-add capabilities, a telephone interface (such as the ClearOne Converge Pro TH20) would be used to transmit sound to distant sites. Secondary audio for presentation segments can be sourced from a VCR or CD player. In larger classroom settings, participants have desktop mics that enable everyone to hear questions and comments.

Microphone mixing and gating parameters can be set to favor the instructor's microphone to facilitate effective dialogue in the room. When a particular microphone gates on, nearby speakers can be attenuated or muted to reduce feedback. Also, participant microphones can be set to gate off when secondary audio sources are in use. The left and right speakers at the front of the room can be configured to provide stereo sound from a secondary audio source, enhancing the training experience. All speakers can be optimized to produce full-fidelity audio by programming the Converge Pros' parametric equalizers and filters accordingly.

Typical distance learning applications also require that video be transmitted. A video codec provides high-quality video to facilitate a complete distance learning experience.

Figure 8.1 shows a scenario including a wireless lapel microphone for the instructor; desktop microphones for participants; ceiling speakers to carry voice (primary) audio and some secondary audio; and left and right speakers at the front of the room, which carry primary and secondary audio.

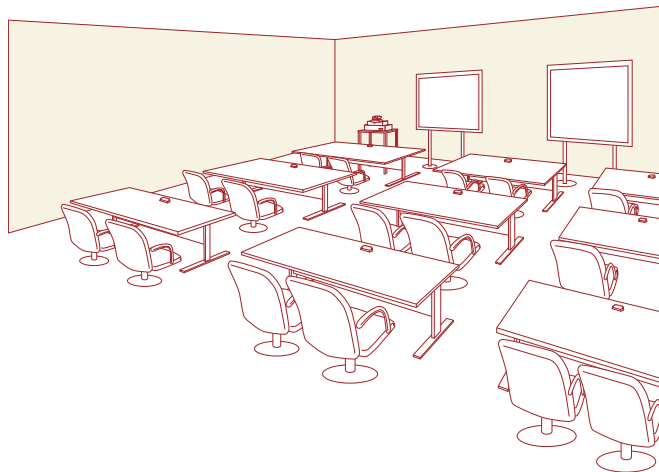

**Figure 8.1**

### COURTROOM

A courtroom application requires that the sound system be precisely calibrated so that all voice audio—including that from the judge, legal counsel, witnesses, and the jury—is easy to understand. The Converge Pro includes many features which enhance the performance of any courtroom audio system.

ClearOne's Converge Pro TH20 is easily integrated into the courtroom system, allowing participants on a phone line to be heard clearly throughout the courtroom. This is an ideal addition to the system because it allows people to appear in the court telephonically—reducing travel expenses and wasted time.

During courtroom sessions, judges might want to hold sidebar conversations with counsel. To prevent jurors from hearing these conversations, noise masking can be sent out of the jurors' speakers.

Everything that transpires in the courtroom must be recorded. You can configure the Converge Pro to accommodate this requirement by routing all outputs to the court recorder—without gating.

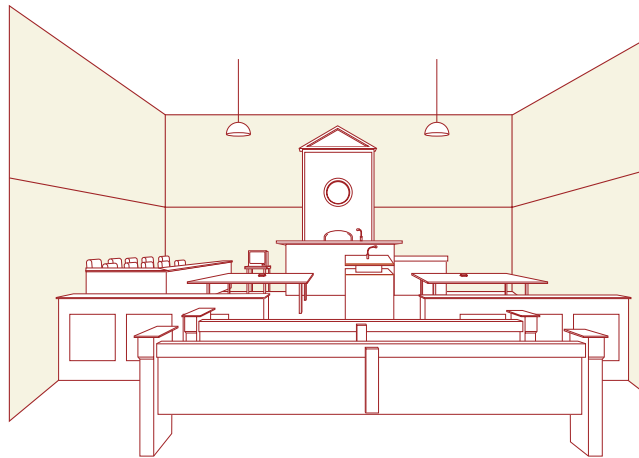

**Figure 8.2**

## BOARDROOM

A boardroom application is a good example of a situation where microphone mixing and gating become critical to providing seamless dialogue between several people seated around a large table and at distant sites. Figure 8.2 shows a boardroom scenario with seven participants, each with their own microphone and speaker. Also, there are observer seating areas on the periphery of the room with speakers for monitoring the discussion at the table. Boardrooms typically use audio and video conferencing capabilities. In this scenario, a Converge Pro TH20 is used for bringing in phone line audio and a video codec is used for video conferencing. The Converge Pro 880 allows you to integrate both simultaneously.

Figure 8.3 shows how audio from the video conference and program audio will come from the front left and right speakers, which directs participants' attention to the person speaking on the video screen. Local microphone audio is routed to the ceiling speakers for reinforcement.

Each loudspeaker receives audio only from those microphones that are not located physical close to the loudspeakers, minimizing acoustic coupling of microphone and speakers. This prevents feedback. This approach is easy to implement in a Converge Pro system using the matrix mixer. Various parametric equalizers and filters might be configured for particular microphones to enhance the voice qualities of regular participants who sit in assigned seats. All audio would be routed to the observation areas at normal levels.



**Figure 8.3**

# APPENDIX: SPECIFICATIONS

## CONVERGE PRO 880 SPECIFICATIONS

### Audio Performance

- Conditions: Unless otherwise specified, all measurements are performed with a 20 Hz to 22 kHz BW limit (no weighting)
- Frequency Response: 20 Hz to 22 kHz  $\pm$ 1dB
- Noise (EIN): -126 dBu, 20 kHz BW, max gain,  $R_s=150 \Omega$
- THD+N: <0.02%
- Dynamic Range: 100 dB (non A-weighted)
- Crosstalk <-91 dB re 20 dBu @ 20 kHz channel to channel

### Auto Mixer Parameters

- Number of Open Microphones (NOM)
- PA Adaptive Mode
- First Mic Priority Mode
- Last Mic Mode
- Maximum # of Mics Mode
- Ambient Level
- Gate Threshold Adjust
- Off Attenuation Adjust
- Hold Time
- Decay Rate

### Assignable Processing Blocks

- Filters:
  - » All pass
  - » Low pass
  - » High pass
  - » Low shelving
  - » High shelving
  - » Parametric EQ
  - » Notch
  - » CD Horn
- Crossovers:
  - » Bessel
  - » Butterworth
  - » Linkwitz-Riley
- Compressor
  - » Delay; adjustable up to 250 ms

### Assignable Fader Blocks

- Gain/Mute

### Microphone Input Configuration

- Input Gain Adjust
- Mic or Line Level
- Phantom Power on/off
- Echo Cancellation on/off
- Noise Cancellation on/off
- Filters:
  - » All Pass
  - » Low Pass
  - » High Pass
  - » Notch
  - » PEQ
- Mute on/off
- Chairman Override on/off
- AGC on/off
- Automatic Level Control on/off
- Auto Gate/Manual gate
- Adaptive Ambient on/off
- Pre AEC channel

### Mic/Line Inputs 1-8

- Push-on mini-terminal block, balanced, bridging
- Impedance: < 5 K $\Omega$
- Nominal Level: adjustable -56 dBu to 0 dBu (7 dB step coarse gain adjustment)
- Maximum Level: -65 dBu to +20 dBu
- Echo Cancellation: 130 ms tail time (works with 12 dB of room gain)
- Noise Cancellation: 6–15 dB attenuation
- Phantom Power: 24 V, selectable

### Line Inputs 9-12

- Push-on mini-terminal block, balanced, bridging
- Impedance: < 5 K $\Omega$
- Nominal Level: 0 dBu
- Maximum Level: 20 dBu

### Outputs 1-12

- Push-on mini-terminal block, balanced
- Impedance: < 50  $\Omega$
- Nominal Level: 0 dBu
- Maximum Level: 20 dBu

### Expansion Bus In/Out

- Proprietary Network
- RJ-45 (2), 1.9 Mbps
- Category 5 twisted-pair cable, 200' maximum cable length between any two Converge Pro devices

### Ethernet

- Autoswitching with Quality of Connection (QoC)

- 10/100 Mbps Ethernet Network Port
- 10/100 Mbps Ethernet PC Port
- RJ-45 Connectors

#### RS-232

- Serial Command Protocol Only (Console software not supported on RS- 232 port)
- DB-9 female
- 9,600/19,200/38,400/57,600/115,200 baud rate; 8 bits, 1 stop bit, no parity
- Hardware flow control on (default)/off

#### USB

- Version 2.0 Compatible
- Type: B-connector

#### Control/Status Ports

- DB-25 female A/B (2)
- Inputs A/B: active low (pull to ground)
- Outputs A/B: open collector, 40 VDC max, 40 mA each
- +3.3 VDC pins (2) (300 mA over-current protected)

#### Configuration & Administration Software

- Converge™ Console

#### Power Input Range

- Auto-Adjusting
- 100–240 VAC; 50/60 Hz

#### Power Consumption

- 30 W Typical

#### Dimensions (L x D x H)

17.25" x 10.25" x 1.75"  
43.8 x 26 x 4.5 cm

#### Weight

7.5 lbs/3.3375 kg unit weight  
12 lbs/5.4kg shipping weight

#### Operating Temperature

14° F/-10 °C to 122° F/50° C ambient unit temperature

#### Approvals & Compliance

- AES48 compliant (audio equip grounding)
- U.S.A. & Canada
  - » CSA safety listed
- EU Countries
  - » RoHS compliant
  - » WEEE compliant
- See product manual for additional details

#### Optional Accessories

- Converge Pro 880
- Converge Pro 840T

- Converge Pro 8i
- Converge Pro TH20
- Tabletop Controller
- Button Microphone – Omni-Directional
- Button Microphone – Uni-Directional
- Delta Microphone
- Tabletop Microphone – Uni-Directional
- JBL Wall-Mount Speakers

#### Part Number

910-151-880 Converge Pro 880 – 8-channel AEC Microphone Mixer

## CONVERGE PRO 840T SPECIFICATIONS

#### Audio Performance

- Conditions: Unless otherwise specified, all measurements are performed with a 20 Hz to 20 kHz BW limit (no weighting)
- Frequency Response: 20 Hz to 22 kHz ±1dB
- Noise (EIN): -126 dBu, 20 kHz BW, max gain, Rs=150 Ω
- THD+N: <0.02%
- Dynamic Range: 100 dB (non A-weighted)
- Crosstalk <-91 dB re 20 dBu @ 20 kHz channel to channel

#### Auto Mixer Parameters

- Number of Open Microphones (NOM)
- PA Adaptive Mode
- First Mic Priority Mode
- Last Mic Mode
- Maximum # of Mics Mode
- Ambient Level
- Gate Threshold Adjust
- Off Attenuation Adjust
- Hold Time
- Decay Rate

#### Assignable Processing Blocks

- Filters:
  - » All pass
  - » Low pass
  - » High pass
  - » Low shelving
  - » High shelving
  - » Parametric EQ
  - » Notch
  - » CD Horn
- Crossovers:
  - » Bessel
  - » Butterworth
  - » Linkwitz-Riley

- Compressor
  - » Delay; adjustable up to 250 ms

### Assignable Fader Blocks

- Gain/Mute

### Microphone Input Configuration

- Input Gain Adjust
- Mic or Line Level
- Phantom Power on/off
- Echo Cancellation on/off
- Noise Cancellation on/off
- Filters:
  - » All Pass
  - » Low Pass
  - » High Pass
  - » Notch
  - » PEQ
- Mute on/off
- Chairman Override on/off
- AGC on/off
- Automatic Level Control on/off
- Auto Gate/Manual gate
- Adaptive Ambient on/off
- Pre AEC channel

### Mic/Line Inputs 1-4

- Push-on mini-terminal block, balanced, bridging
- Impedance: < 5 K $\Omega$
- Nominal Level: adjustable -56 dBu to 0 dBu
- (7 dB step coarse gain adjustment)
- Maximum Level: -65 dBu to +20 dBu
- Echo Cancellation: 130 ms tail time (works with 12 dB of room gain)
- Noise Cancellation: 6–15 dB attenuation
- Phantom Power: 24 V, selectable

### Line Inputs 5-8

- Push-on mini-terminal block, balanced, bridging
- Impedance: > 5 K $\Omega$
- Nominal Level: 0 dBu
- Maximum Level: 20 dBu

### Outputs 1-8

- Push-on mini-terminal block, balanced
- Impedance: < 50  $\Omega$
- Nominal Level: 0 dBu
- Maximum Level: 20 dBu

### Amplifier Output

- Binding post connection
- 10 Watts @ 4  $\Omega$  Impedance
- THD + Noise: <0.5%

### Telco Line

- RJ-11
- POTS (plain old telephone service) or
- analog extension from a PBX
- A-lead supervision provided

### Telco Set

- RJ-11
- POTS (plain old telephone service) or analog extension from a PBX
- A-lead supervision provided

### Telephone Audio Performance

- Conditions: Unless otherwise specified, all measurements are performed with Transmit Limiter and Receive ALC disabled
- Frequency Response: 250 Hz to 3.3 kHz  $\pm$ 1 dB
- THD+N: <0.3%, re-max level 250 Hz to 3.3 kHz
- SNR: >62 dB re max level

### Telephone Echo Cancellation

- Tail Time: 31 ms
- Null: 55 dB nominal

### Telephone Noise Cancellation

- Noise Cancellation: 6–15 dB attenuation

### Expansion Bus In/Out

- Proprietary Network
- RJ-45 (2), 1.9 Mbps
- Category 5 twisted-pair cable, 200' maximum cable length between any two Converge Pro devices

### Ethernet

- Autoswitching with Quality of Connection (QoC)
- 10/100 Ethernet Network Port
- 10/100 Ethernet PC Port
- RJ-45 Connectors

### RS-232

- Serial Command Protocol Only (Console software not supported on RS-232 port)
- DB-9 female
- 9,600/19,200/38,400/57,600/115,200 baud rate; 8 bits, 1 stop, no parity
- Hardware flow control on (default)/off

### USB

- Version 2.0 Compatible
- Type: B-connector

### Control/Status

- DB-25 female A/B (2)

- Inputs A/B: active low (pull to ground)
- Outputs A/B: open collector, 40 VDC max, 40 mA each
- +3.3 VDC pins (2) (300 mA over-current protected)

### Configuration & Administration Software

Converge™ Console

### Power Input Range

- Auto-adjusting
- 100–240 VAC; 50/60 Hz

### Power Consumption

30W Typical

### Dimensions (L x D x H)

17.25" x 10.25" x 1.75"  
43.8 x 26 x 4.5 cm

### Weight

7.5 lbs/3.3375 kg unit weight  
12 lbs/5.4kg shipping weight

### Operating Temperature

14° F/-10° C to 122° F/50° C ambient room temperature

### Approvals & Compliance

- AES48 compliant (audio equip grounding)
- U.S.A. & Canada
  - » CSA safety listed
- EU Countries
  - » RoHS compliant
  - » WEEE compliant
- See product manual for additional details

### Optional Accessories

- Converge Pro 880
- Converge Pro 8i
- Converge Pro TH20
- Tabletop Controller
- Button Microphone – Omni-Directional
- Button Microphone – Uni-Directional
- Delta Microphone
- Tabletop Microphone – Uni-Directional
- JBL Wall-Mount Speakers

### Part Number

910-151-840 Converge Pro 840T – 4-channel AEC Microphone Mixer with built-in telephone hybrid amplifier

## CONVERGE PRO 8i SPECIFICATIONS

### Audio Performance

- Conditions: Unless otherwise specified, all measurements are performed with a 20 Hz to 20 kHz BW limit (no weighting)

- Frequency Response: 20 Hz to 20 kHz  $\pm 1$ dB
- Noise (EIN): -126 dBu, 20 kHz BW, max gain,  $R_s = 150 \Omega$
- THD+N: <0.02%
- Dynamic Range: 100 dB (non A-weighted)
- Crosstalk <-91 dB re 20 dBu @ 20 kHz channel to channel

### Auto Mixer Parameters

- Number of Open Microphones (NOM)
- PA Adaptive Mode
- First Mic Priority Mode
- Last Mic Mode
- Maximum # of Mics Mode
- Ambient Level
- Gate Threshold Adjust
- Off Attenuation Adjust
- Hold Time
- Decay Rate

### Assignable Processing Blocks

- Filters:
  - » All pass
  - » Low pass
  - » High pass
  - » Low shelving
  - » High shelving
  - » Parametric EQ
  - » Notch
  - » CD Horn
- Crossovers:
  - » Bessel
  - » Butterworth
  - » Linkwitz-Riley
- Compressor
  - » Delay; adjustable up to 250 ms

### Assignable Fader Blocks

- Gain/Mute

### Microphone Input Configuration

- Input Gain Adjust
- Mic or Line Level
- Phantom Power on/off
- Echo Cancellation on/off
- Noise Cancellation on/off
- Filters:
  - » All Pass
  - » Low Pass
  - » High Pass
  - » Notch
  - » PEQ
- Mute on/off

- Chairman Override on/off
- AGC on/off
- Automatic Level Control on/off
- Auto Gate/Manual gate
- Adaptive Ambient on/off
- Pre AEC channel

#### Mic/Line Inputs 1-8

- Push-on mini-terminal block, balanced, bridging
- Impedance: < 5 K $\Omega$
- Nominal Level: adjustable -56 dBu to 0 dBu
- (7 dB step coarse gain adjustment)
- Maximum Level: -65 dBu to +20 dBu
- Echo Cancellation: 130 ms tail time (works with 12 dB of room gain)
- Noise Cancellation: 6–15 dB attenuation
- Phantom Power: 24 V, selectable

#### Line Inputs 9-12

- Push-on mini-terminal block, balanced, bridging
- Impedance: < 5 K $\Omega$
- Nominal Level: 0 dBu
- Maximum Level: 20 dBu

#### Expansion Bus In/Out

- Proprietary Network
- RJ-45 (2), 1.9 Mbps
- Category 5 twisted-pair cable 200' maximum cable length between any two Converge Pro products

#### Ethernet

- Autoswitching with Quality of Connection (QoC)
- 10/100 Mbps Ethernet Network Port
- 10/100 Mbps Ethernet PC Port
- RJ-45 Connectors

#### RS-232

- Serial Command Protocol Only (Console software not supported on RS-232 port)
- DB-9 female
- 9,600/19,200/38,400/57,600/115,200 baud rate; 8 bits, 1 stop, no parity
- Hardware flow control on (default)/off

#### USB

- Version 2.0 compatible
- Type B connector
- Control/Status
- DB-25 female A/B (2)
- Inputs A/B: active low (pull to ground)
- Outputs A/B: open collector, 40 VDC max, 40 mA each
- +3.3 VDC pins (2) (300 mA over-current protected)

- Configuration & Administration Software
- Converge Consolem

#### Power Input Range

- Auto-adjusting
- 100–240 VAC; 50/60 Hz

#### Power Consumption

30 W Typical

#### Dimensions (L x D x H)

17.25" x 10.25" x 1.75"  
43.8 x 26 x 4.5 cm

#### Weight

7.5 lbs/3.3375 kg unit weight  
12 lbs/5.4kg shipping weight

#### Operating Temperature

14° F/-10° C to 122° F/50° C ambient unit temperature

#### Approvals & Compliance

- AES48 compliant (audio equip grounding)
- U.S.A. & Canada
  - » CSA safety listed
- EU Countries
  - » RoHS compliant
  - » WEEE compliant
- See product manual for additional details

#### Optional Accessories

- Converge Pro 880
- Converge Pro 840T
- Converge Pro TH20
- Tabletop Controller
- Button Microphone – Omni-Directional
- Button Microphone – Uni-Directional
- Delta Microphone
- Tabletop Microphone – Uni-Directional
- JBL Wall-Mount Speakers

#### Part Number

910-151-810 Converge Pro 8i – 8-channel AEC Microphone Mixer (no outputs)

## CONVERGE PRO TH20 SPECIFICATIONS

#### Telephone Audio Performance

- Conditions: Unless otherwise specified, all measurements are performed with Transmit Limiter and Receive ALC disabled
- Frequency Response: 250Hz to 3.3 kHz  $\pm$ 1dB
- THD+N: <0.3% re-max level 250 Hz to 3.3 kHz
- SNR: > 62 dB re-max level

#### Telephone Noise Cancellation

- Noise Cancellation 6-15 dB attenuation

### Telco Line Echo Cancellation

- Tail Time: 31 ms
- Null: 55 dB nominal

### Telco Line

- RJ-11
- POTS (plain old telephone service) or analog extension from a PBX
- A-lead supervision provided

### Telco Set

- RJ-11
- POTS (plain old telephone service) or analog extension from a PBX
- A-lead supervision provided

### Audio Performance

- Conditions: Unless otherwise specified, all measurements are performed with a 20 Hz to 20 kHz BW limit (no weighting)
- Frequency Response: 20 Hz to 20 kHz  $\pm 1$ dB  
Rs=150  $\Omega$
- THD+N: <0.02%
- Dynamic Range: 100 dB (non A-weighted)
- Crosstalk <-91 dB re 20 dBu @ 20 kHz channel to channel

### Line Inputs 1, 2

- Push-on mini-terminal block, balanced, bridging
- Impedance: < 5 k $\Omega$
- Nominal Level: 0 dBu
- Maximum Level: 20 dBu

### Line Outputs 1,2

- Push-on mini-terminal block, balanced
- Impedance: < 50 k $\Omega$
- Nominal Level: 0 dBu
- Maximum Level: 20 dBu

### Expansion Bus In/Out

- Proprietary Network
- RJ-45 (2), 1.9 Mbps, 110 K $\Omega$  Impedance
- Category 5 twisted-pair cable, 200' maximum cable length between any two Converge Pro devices

### Ethernet

- Autoswitching with Quality of Connection (QoC)
- 10/100 Mbps Ethernet Network Port
- 10/100 Mbps Ethernet PC Port
- RJ-45 Connectors

- Serial Command Protocol Only (Console software not supported on RS- 232 port)
- DB-9 female
- 9,600/19,200/38,400/57,600/115,200 baud rate; 8 bits,
- 1 stop bit, no parity
- Hardware flow control on (default)/off

### USB

- Version 2.0 compatible
- Type: B-connector

### Control/Status Ports

- DB-25 female A/B (2)
- Inputs A/B: active low (pull to ground)
- Outputs A/B: open collector, 40 VDC max, 40 mA each
- +3.3 VDC pins (2) (300 mA over-current protected)

### Configuration & Administration Software

Converge™ Console

### Power Input Range

- Auto-Adjusting
- 100–240 VAC; 50/60 Hz

### Power Consumption

30 W Typical

### Dimensions (L x D x H)

17.25" x 10.25" x 1.75"  
43.8 x 26 x 4.5 cm

### Weight

7.5 lbs/3.3375 kg unit weight  
12 lbs/5.4kg shipping

### Operating Temperature

14° F/-10° C to 122° F/50° C ambient unit temperature

### Optional Accessories

- Converge Pro 880
- Converge Pro 8i
- Converge Pro TH20
- Tabletop Controller
- Button Microphone - Omni-Directional
- Button Microphone – Uni-Directional
- Delta Microphone
- Tabletop Microphone – Uni-Directional
- JBL Wall-Mount Speakers

### Part Number

910-151-820 Converge Pro TH20 Telephone Interface for Converge Pro 880, 840T, 8i

## RS-232



## GLOSSARY

### **Acoustic Echo Cancellation (AEC)**

A process in which acoustical echo is removed from a signal. AEC can be used to remove unwanted signals from mic audio if the unwanted acoustic signal is available separately as an electronic signal.

### **Adaptive Ambient**

This portion of the mixer monitors the varying ambient noise level in the room and changes the threshold level at which a microphone gates on.

### **Ambient Level**

The manually-set background noise level upon which the Converge Pro 880/840T bases gating protocols. Used only if the Adaptive Ambient feature isn't used.

### **Ambient Noise**

The existing room-level noise, such as that caused by ventilation systems, paper shuffling, and background chatter.

### **ASCII**

The American Standard Code (for) Information Interchange. Standard code for transmitting alphanumeric characters electronically.

### **Attack**

This signal parameter determines how quickly compression is enabled. It is calibrated in milliseconds.

### **Attenuation**

A reduction of signal amplitude.

### **Audio Processor**

A device that modifies an audio signal in response to certain requirements.

### **Automatic Gain Control (AGC)**

Automatically increases or decreases audio gain to maintain a consistent audio level.

### **Automatic Gating**

Automatically gates microphones on or off based on input levels and other parameters programmed into the Converge Pro 880/840T.

### **Bandwidth**

The difference between the lower and upper 3dB endpoints of an audio band. Also, the range or differences between the limiting frequencies of a continuous frequency band.

### **Baud Rate**

The number of signal transitions per second, or the clock rate of the serial bit stream in hertz. Given 7 or 8 bits for data plus start and stop, the approximate ASCII character transmission rate is one-tenth the baud rate.

### **Chairman Override**

Provides gating priority for all microphones selected for the chairman override group. When a mic in this group gates on, all microphones not included in this group gate off.

### **Clipping**

A condition in which a signal level exceeds the maximum level a circuit can handle. This is usually caused by overdriving an input. It always causes distortion and typically leads to listener fatigue and accelerated failure of loudspeaker drivers.

### **Compression**

An induced reduction in the dynamic range of part or all of an audio signal. Compression is usually used to protect individual loudspeaker components from the damaging effects of transients.

### **Constant Directivity Horn Equalizer (CD Horn EQ)**

Horn drivers commonly used in arrays in arenas and auditoriums have an inherent 6dB/octave high frequency rolloff. The Converge Pro 880/840T CD Horn EQ compensates for this characteristic.

### **Converge Console Software**

The Converge Pro setup and configuration software.

### **Crossover**

A device that passes designated frequency segments of an audio signal to various loudspeaker elements in a sound system.

### **Crossover, Bessel**

A crossover using a low-pass filter design characterized by a linear phase response. This results in a constant time delay throughout the passband.

### **Crossover, Butterworth**

A crossover using a low-pass filter design characterized by a maximally flat magnitude response. This results in no amplitude ripple in the passband.

### **Crossover, Linkwitz-Riley**

A fourth-order crossover consisting of a cascaded second-order Butterworth low-pass filter. Offers a vast improvement over the Butterworth crossover and is the de facto standard for professional audio active crossovers.

### **Decay Rate (slow, medium, fast)**

Programs how quickly the audio level is attenuated once a channel has been gated off.  
DSP Digital signal processor.

### **Echo Canceller Reference**

The signal point which contains an electronic copy of all signals which will be removed from the signal the mics pick up. This is always the far-end audio and, optionally, local program material.

### **Expansion bus**

Consists of two RJ-45 connectors on the rear panel of the Converge Pro 880/840T. An expansion bus allows multiple Converge Pro units to be networked together using category five twisted-pair (10BaseT) cable.

### **Filter**

A device that passes and blocks audio signals based on user-definable requirements of the system.

### **Filter, All Pass**

A filter that provides only phase shift or phase delay without appreciably changing the magnitude characteristic. The filter produces a flat amplitude response. It is useful for matching the delay of two processing channels with different delays.

### **Filter Display**

A group of nodes plotted on a logarithmic scale. The Converge Pro 880/840T filter display can be accessed through the Inputs 1–8/1–4, From Processing, or To Processing windows.

### **Filter, High Pass**

A filter that passes high signal frequencies while attenuating low frequencies. The gain or loss

### **Filter, High Shelving**

Provides boosting or attenuation of frequencies above a designated frequency. The transition between the spectrum above and below the designated frequency occurs at a fixed 6dB/octave rate. The gain or loss above the corner frequency is adjustable to +/- 15dB.

### **Filter, Low Pass**

A filter that passes low frequencies while attenuating high frequencies.

### **Filter, Low Shelving**

Provides boosting or attenuation of frequencies below a designated frequency. The transition between the spectrum above and below the designated frequency occurs at a fixed 6dB/octave rate. The gain or loss below the corner frequency is adjustable to +/- 15dB.

### **First Mic Priority**

Increases the audio level required to gate on additional microphones after the first mic is on. This helps ensure that only one mic gates on when a person speaks.

### **Gain**

The amount a signal is increased over a given reference, typically 0. Normally specified in dB (decibels). On the Converge Pro 880/840T, gain is adjustable from -65 to 20dB (85dB range) in .5dB increments.

### **Gain Structure**

The configuration of parameters which define gain adjustment of a signal. The optimal input gain setting is one which provides both an adequate signal-to-noise ratio and reasonable headroom.

### **Gate Ratio**

Specifies how much louder the microphone audio level must be above the ambient sound level before a microphone gates on.

### **GPIO (general purpose input/output)**

The Control/Status Ports A and B on the rear of the unit.

### **Hold Time**

The length of time that a microphone remains on after the voice (input) level drops below the gate ratio. This prevents the microphone from gating off during brief pauses in speech.

### **Last On Mode**

Sets the last-activated mic to Last On, Mic 1–8/1–4, or Off. The Last On setting leaves the last-activated mic gated on until another mic input gates on.

### **Macro**

A series of user-created instructions, stored within the unit, which can be executed from an RS-232 command or contact closure.

### **Macro Mode**

The section of Converge Console that allows you to customize and execute macro commands for a Converge Pro unit or network.

### **Manual Gating**

Provide the ability to gate a microphone on or off manually.

### **Matrix Mixer**

A mixer that allows routing of any input or combination of inputs to an output or any combination of outputs. In the case of the Converge Pro 880, the matrix mixer permits level control at each cross point in the matrix.

### **Maximum Number of Mics/Filibuster**

Sets the maximum number of mics that can be gated on simultaneously.

### **Microphone Activation**

A condition in which a microphone is gated on.

### **Microphone Mixing**

A situation in which audio from mics on different signal lines are mixed together. All mic signals can be mixed to one signal line, any or all outputs, or mixed into separate groups. Mic signals can also be processed together or individually.

### **Microphone 1 Mode**

Reverts mic assignment to a designated mic when all mics gate off.

### **Mute**

A condition in which an audio signal is attenuated below the audible threshold.

Noise Cancellation A process through which ambient noise is removed from a signal.

### **Number of Open Mics (NOM)/Constant Gain Mode**

Adjusts the output level based on the number of mics gated on and routed to an output.

### **Off Attenuation**

The amount of level reduction a microphone is given when the microphone is not gated on.

### **PA Adaptive Mode**

The Converge Pro 880/840T recognizes how much loudspeaker audio is picked up by the microphones and then uses this level as the new ambient level when audio is present at the power amplifier. This prevents loudspeaker audio from gating ON a microphone, while still allowing people in the room to gate on microphones as they speak.

### **PA Adaptive Reference**

This Converge Console setting determines which output (typically for a loudspeaker) is used as a reference for an input.

### **Paging Zone**

A subset of a paging system. Intended to isolate paging system outputs to specific areas.

### **Parametric Equalizer (PEQ)**

A multi-band variable equalizer with control of gain, center frequency, and bandwidth. A properly configured PEQ enables the Converge Pro to offset speaker or room acoustic deficiencies.

### **Phantom Power**

supplied by the Converge Pro to power most condenser microphones. The Converge Pro 880/840T provides 24 volts of phantom power. This feature can be switched off for devices not requiring phantom power.

### **Phase Plot**

A plot of phase angle (-180 to 180 degrees) vs. frequency (20Hz to 20kHz) on a logarithmic scale.

### **Pink Noise**

An audio test signal containing all the frequencies in a given audio spectrum, with equal energy in each octave.

### **Preset**

One of 32 configurable memories in the Converge Pro 880/840T. A preset can be programmed with a variety of routing, level, gating, delay, filter, and equalizer settings to meet specific application requirements.

### **Preset Mask**

Defines whether a contact closure activates on a low or high signal on the rear panel of the unit.

### **Q Quality factor**

It is the ratio of the center frequency divided by the bandwidth. Q reflects an inverse relationship to the bandwidth, and adjusts from .02:1 to 40:1 on the Converge Pro 880/840T.

### **Ratio**

The amount of compression applied to the output signal compared with the input signal as the signal exceeds the threshold level.

### **Release**

Release is a parameter which determines how quickly compression is released after the input signal drops below the threshold.

### **Reverberation**

A diffuse acoustic energy field fed and maintained by sound reflections from the room surfaces.

### **Serial Command**

A bit description designed to execute an instruction or command.

### **Signal Delay**

Used for:

1. Compensating for physical placement of multiple drivers in a cluster—to align points of acoustic origin in the same plane.
2. Ensure matching arrival times at listeners from multiple loudspeaker drivers.
3. Using the Haas effect to maintain localization of the source, even with a distributed system.

**Signal Generator**

A device for generating a reference tone for sound system calibration purposes.

**Speech Leveler**

Essentially an AGC applied to a speech signal after processing by a noise cancellation stage. Acts only on voice signals. Does not pull up the noise floor during periods of no signal.

**Table View**

Displays the numerical values of the filter parameters for all nodes of the active filter display.

**Threshold**

The upper or lower level at which a signal processing mechanism begins or terminates operation.

**White Noise**

Acoustical noise with equal energy throughout a given frequency range.

