

TS612 Drop-in Module Instruction Sheet

Introduction

The TS612 Drop-in Module provides the full set of TS612 control-surface features on a convenient panel that mounts within your audio console. This module can be installed vertically or side-by-side (if split module version) to maximize space.

This instruction sheet provides step-by-step instructions for installing all configurations of the TS612 Drop-in Module. For set up or operation instructions, refer to the **TS612 Installation and Operations Manual**.

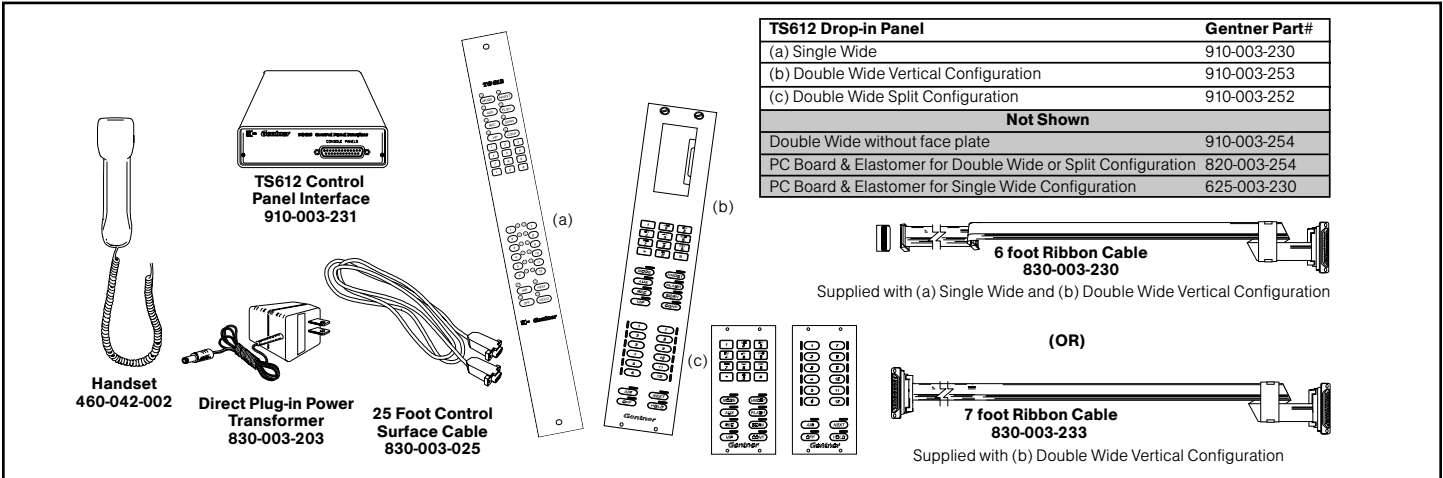

Figure 1. Equipment diagram.

Power Requirements

The Control panel interface Requires 12VDC at 500mA.

Equipment Placement

The TS612 Drop-in Module should be placed directly into a vacant slot within your audio console. The TS612 Control Panel Interface (CPI) should be placed within 7 feet of the drop-in module.

Note: The CPI and 7-foot ribbon cable should be placed away from critical analog circuits to prevent digital signals from interfering with analog signals.

Audio Console Preparation

The TS612 Drop-in Module fits standard single- or double-wide channel slots (depending on selection). Remove the cover from the blank channel insert of your console according to the manufacturer's instructions.

Installation

The TS612 Drop-in Module is used in place of the standard TS612 Control Surface.

Completed Installation

Figure 2 shows the TS612 Drop-in Module when installation is complete. Follow these step-by-step instructions to install the TS612 Drop-in Module:

! Gentner Communications is not responsible for damage incurred during shipment. You must make claims directly with the carrier. Inspect your shipment carefully for obvious signs of damage. If the shipment appears to be damaged, retain the original boxes and packing material for inspection by the carrier.

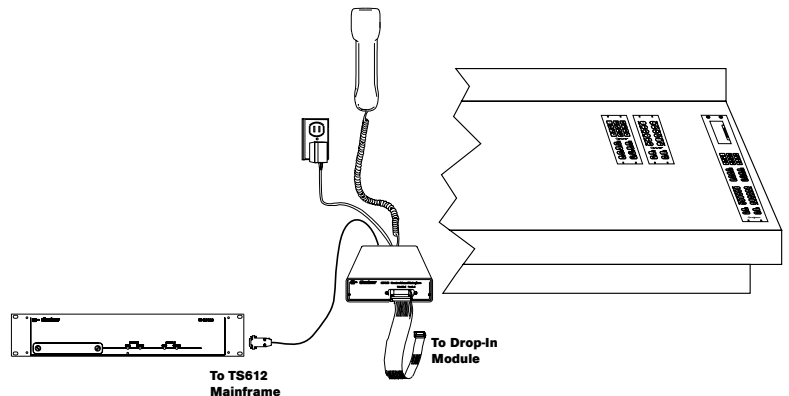

Figure 2. Properly installed TS612 Drop-in Module system.

Step 1

Identify where you will mount the TS612 Drop-in Module in your audio console.

Step 2

Attach the ribbon cable to the TS612 Drop-in Module (Figure 3). To ensure correct power polarity, ensure that pin 1 (red) wire is connected to pin 1 on the TS612 Drop-in Module PCBs.

Step 3

Thread the D connector end of the ribbon cable out through the opening in the back of the audio console.

Step 4

Connect the D connector end of the ribbon cable to the front of the TS612 CPI (Figure 4) at the 25-pin port labeled CONSOLE PANELS.

Step 5

Attach the power cable to the CPI's POWER port (Figure 5).

Step 6

Attach the 25-foot control-surface cable from the back of the CPI at the port labeled MAINFRAME CS (Figure 5) to the appropriate TS612 mainframe control surface port (Figure 6).

Step 7

Connect the handset to the CPI's HEADSET port (Figure 5).

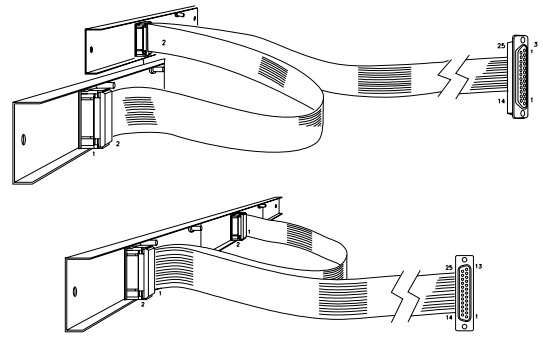

Figure 3. Ribbon cable attachment.

Note: Because the ribbon cable is parallel, it does not matter which 20-pin IDC connector is attached at the top of the Drop-in Module.

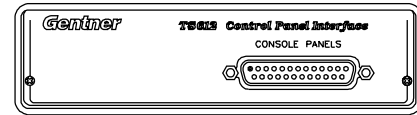

Figure 4. Console Panel ribbon cable attachment.

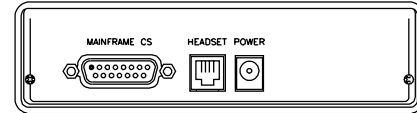

Figure 5. Mainframe Control Surface cable attachment.



Operation Note: The TS612 Drop-in Module provides the same operational features as the standard TS612 Control Surface except that

the MUTE button has been replaced with a button labeled HNDSET. When selected, this button activates handset mode and the Handset LED glows green.

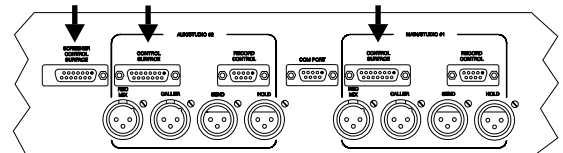

Figure 6. Serial cable mainframe attachment.

Warranty

Gentner Communications Corporation (Manufacturer) warrants that this product is free of defects in both materials and workmanship. Should any part of this equipment be defective, Manufacturer agrees, at its option, to:

- A. Repair or replace any defective part free of charge (except transportation charges) for a period of one year from the date of the original purchase, provided the owner returns the equipment to the Manufacturer at the address set forth below. No charge will be made for parts or labor during this period;
- B. Furnish replacement for any defective parts in the equipment for a period of one year from the date of original purchase. Replacement parts shall be furnished without charge, except labor and transportation.

This Warranty excludes assembled products not manufactured by Manufacturer whether or not they are incorporated in a Manufacturer product or sold under a Manufacturer part or model number.

THIS WARRANTY IS VOID IF:

- A. The equipment has been damaged by negligence, accident, act of God or mishandling, or has not been operated in accordance with the procedures described in the operating and technical instructions; or,
- B. The equipment has been altered or repaired by other than Manufacturer or an authorized service representative of Manufacturer; or,
- C. Adaptations or accessories other than those manufactured or provided by Manufacturer have been made or attached to the equipment which, in the determination of Manufacturer, shall have affected the performance, safety or reliability of the equipment; or,
- D. The equipment's original serial number has been modified or removed.

NO OTHER WARRANTY, EXPRESS OR IMPLIED, INCLUDING WARRANTY OF MERCHANTABILITY OR FITNESS FOR ANY PARTICULAR USE, APPLIES TO THE EQUIPMENT, nor is any person or company authorized to assume any warranty for Manufacturer or any other liability in connection with the sale of Manufacturer's products. Manufacturer does not assume any responsibility for consequential damages, expenses or loss of revenue or property, inconvenience or interruption in operation experienced by the customer due to a malfunction in the purchased equipment. No warranty service performed on any product shall extend the applicable warranty period. In case of unsatisfactory operation, the purchaser shall promptly notify Manufacturer at the address set forth below in writing, giving full particulars as to the defects or unsatisfactory operation. Upon receipt of such notice, Manufacturer will give instructions respecting the shipment of the equipment, or such other matters as it elects to honor this warranty as above provided. This warranty does not cover damage to the equipment during shipment and Manufacturer assumes no responsibility for such damage. All shipping costs shall be paid by customer. This warranty extends only to the original purchaser and is not assignable or transferable.

Gentner Communications Corporation
1825 Research Way, Salt Lake City, UT 84119

TECHNICAL SUPPORT: 1.800.283.5936 (USA) OR 1.801.974.3760

