



SPH-5/5E

*Installation and
Operations Manual*

SPH-5/5E Installation and Operations Manual

Copyright© 1993 by Gentner Communications Corporation. All rights reserved. No part of this manual may be reproduced in any form or by any means without permission from Gentner Communications Corporation.

Printed in the United States of America. Gentner Communications Corporation reserves specification privileges.

Information in this manual is subject to change without notice.

Gentner Part No. 800-011-001

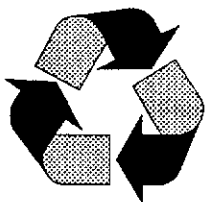

Gentner Communications Corporation is committed to protecting the environment and preserving our natural resources.

This manual has been printed entirely on recycled paper.

SPH-5/5E Telephone Hybrid Operations Manual

Date of this revision: January 29, 1990

Table of Contents

SECTION ONE -- THE BASICS	1
1.1 Introduction	1
1.2 Overview	3
1.3 Brief Technical Description.....	7
1.4 Physical Specifications.....	11
1.5 Electrical Specifications	12
1.6 Audio Interface	14
1.7 SPH-5/5E Rear Panel Connectors.....	15
SECTION TWO -- WARRANTY INFORMATION AND NOTICES	17
2.1 Warranty Agreement.....	17
2.2 Special Notices	19
2.3 Product Line Updates.....	20
SECTION THREE -- INSTALLATION.....	21
3.1 Unpacking Your SPH-5/5E Telephone Hybrid.....	21
3.2 Mounting Your SPH-5/5E Telephone Hybrid.....	22
3.3 Setting Up the AC Power Input.....	23

3.4	Connecting the SPH-5/5E Directly to a Single Central Office Telephone Line	25
3.5	Connecting the SPH-5/5E Telephone Hybrid to a 1A2 Key Service Unit	27
3.6	Using the SPH-5/5E with an Existing Multi-Line Telephone Set	28
3.7	Using a Gentner Telemix IX as a Call Director	31
3.8	Using a Gentner Telemix X as a Call Director	32
3.9	Compatibility with Electronic KSU Telephone Sets	37
3.10	Connecting the SPH-5/5E to an Electronic Key Service Telephone Set	38
3.11	Connecting the SPH-5/5E to Audio Equipment	42
3.12	The REMOTE Connector	46
3.13	The TAPE Connector	53
3.14	The XLR Audio Connectors	56
3.15	The LINE and SET Telephone Connectors	58
SECTION FOUR -- OPERATION		59
4.1	Overview	59
4.2	Hybrid Null Setup Procedure	61
4.3	Adjusting the MAIN Send and CUE Send Input Levels	63
4.4	Caller Level, Caller Control, and Caller Threshold	66
4.5	Setting the DIP Switches	68
4.6	Selection of Send Audio Band-Width	74
4.7	Front Panel Controls and Indicators	77
4.8	Remote Control of SPH-5/5E Telephone Hybrid Functions	81
4.9	Remote Indicators	93
4.10	Adding External Relays	95

SECTION FIVE -- AUDIO CONFERENCING.....	97
5.1 Overview	97
5.2 Audio Conferencing Installation.....	99
5.3 Setting the DIP Switches.....	108
5.4 Conference Room Setup.....	114
5.5 Auditoriums or Large Meeting Rooms	116
5.6 Video Conferencing or Business Television Use.....	118
SECTION SIX -- TYPICAL BROADCAST APPLICATIONS	120
6.1 Typical Broadcast Applications.....	120
6.2 Conferencing Multiple SPH-5/5E Units	123
SECTION SEVEN -- THEORY OF OPERATION.....	127
7.1 Overview	127
7.2 Send Audio Circuit Description.....	129
7.3 Caller Audio Circuit Description.....	131
7.4 Telephone Interface Circuit Description.....	132
SECTION EIGHT -- MAINTENANCE.....	133
8.1 SPH-5/5E Telephone Hybrid Maintenance	133
8.2 Questions and Answers.....	134
8.3 Schematics	139

SPH-5/5E Telephone Hybrid Operations Manual

Table of Figures

Figure 1 - Front Panel Functions	8
Figure 2 - Rear Panel Summary.....	9
Figure 3 - Functional Block Diagram.....	10
Figure 4 - Setting Up the AC Power Input.....	24
Figure 5 - Connecting to a Single Central Office Line.....	26
Figure 6 - Using an Existing Multi-Line Telephone Set.....	30
Figure 7 - Connection to a Single Telemix X Call Director.....	34
Figure 8 - Connection to a Dual Telemix X Call Director.....	35
Figure 9 - Connection to Digital Telephones.....	39
Figure 10 - Installation in a Digital Telephone System with DC on the Audio Pair.....	40
Figure 11 - Function of a Telephone Hybrid.....	43
Figure 12 - SPH-5/5E Telephone Hybrid Audio Connections.....	44
Figure 13 - REMOTE Connector Audio Pin-outs	47
Figure 14 - DB-9 TAPE Connector Pin Location	54
Figure 15 - SPH-5/5E Front Access Panel.....	60
Figure 16 - Remote On/Off Control.....	73
Figure 17 - Location Diagram for JP1 and JP2.....	75
Figure 18 - Remote Record Control	83
Figure 19 - Remote Cue (Hold) Control.....	85
Figure 20 - Remote Send and Caller (Receive) Muting	87

Figure 21 - Auxiliary Relay Pin-out	89
Figure 22 - Remote Tape Start/Stop/Record Control.....	92
Figure 23 - Remote Indicators	94
Figure 24 - Adding External Relays	96
Figure 25 - Front Panel Functions	98
Figure 26 - Basic Audio Conferencing Setup	101
Figure 27 - Setting Up the AC Power Input.....	102
Figure 28 - SPH-5/5E Audio Connections.....	103
Figure 29 - REMOTE Connector Audio Pin-out.....	104
Figure 30 - Rear Panel Summary.....	106
Figure 31 - REMOTE and TAPE Connectors' Pin-outs.....	107
Figure 32 - Front Access Panel Details.....	109
Figure 33 - Conference Room Setup.....	115
Figure 34 - Auditorium Setup.....	117
Figure 35 - Typical Broadcast Application	122
Figure 36 - Dual Hybrid Single and Multi-Line Conference	124
Figure 37 - Dual Hybrids with Separate Audio Outputs	125
Figure 38 - Dual Hybrids with Mixed Audio Outputs.....	126
Figure 39 - Functional Block Diagram.....	128

SPH-5/5E Telephone Hybrid Operations Manual

Date of this revision: January 29, 1990

SECTION ONE -- THE BASICS

1.1 Introduction

This manual will provide all the information you need to properly use and maintain either the Gentner SPH-5 or the Gentner SPH-5E Telephone Hybrid. The SPH-5E is identical to the SPH-5 except that it includes selectable frequency extension.

This manual includes information pertaining to both **broadcast** and **audio conferencing** users. Please read this manual thoroughly before attempting to use your unit.

Please refer to this manual first if you have any questions or problems regarding the use of the SPH-5/5E. If you can't find an answer in the manual, please contact:

**Gentner Electronics Corporation
Customer Support
1825 Research Way
Salt Lake City, Utah 84119
Telephone: (801) 975-7200
Facsimile: (801) 977-0087**

Please check your SPH-5/5E shipment to be certain that each item listed below is included. If any item is missing, notify Gentner immediately.

ITEM	GENTNER PART NUMBER
a) [1] SPH-5 Unit Assembly	850-011-001
or	
a) [1] SPH-5E Unit Assembly	850-011-201
b) [1] Operations Manual	800-011-001
c) [4] Rack Screws	681-400-001
d) [6] Rack Cups	684-400-001
e) [1] Warranty Registration Card	432-600-000
f) [1] Modular Telephone Cord	830-000-012
g) [1] DB-25 Connector	671-020-025
h) [1] Hood for DB-25 Connector	671-000-025
i) [1] DB-9 Connector	671-020-009
j) [1] Hood for DB-9 Connector	671-000-009
k) [1] Molded Power Cord	699-150-006
l) [1] HOLD Button Legend	622-003-004

1.2 Overview

The SPH-5E features built-in Frequency Extension. By means of an encode/decode process, the typical bandwidth of audio sent over standard telephone lines becomes 50 Hz to 2500 Hz. This provides you with clear, intelligible, and good-sounding audio over standard telephone lines.

The Gentner SPH-5/5E Telephone Hybrid utilizes the latest refinements in analog techniques to optimize the isolation between the Send and Receive sides of a telephone conversation. The unit works well in both **broadcast and audio conferencing** applications.

The SPH-5/5E connects directly to the telephone line and interfaces directly with your audio equipment.

The performance advances provided by the Gentner SPH-5/5E help reduce feedback through the hybrid, even when you have an open microphone in the same room with a loudspeaker.

The SPH-5/5E provides a Caller Control Circuit, which permits caller audio to be dimmed (reduced) by an adjustable amount when Send audio is present.

Remote control functions of the unit can be accessed via a single rear panel REMOTE connector.

A removable metal panel on the front of the unit allows access to the following controls:

MAIN SEND LEVEL
CUE SEND LEVEL
CALLER LEVEL
CALLER CONTROL
CALLER CONTROL THRESHOLD

Hybrid null adjustments are available, as well as DIP Switches for programming other functions and features of the SPH-5/5E.

The unit has two LED indicators on the front panel. The SEND and CALLER LED's flash green to indicate the presence of respective audio, and flash red to indicate a level of 6 dB before clipping. This helps you prevent distortion due to excessive audio levels.

The Gentner SPH-5/5E incorporates a RECORD function which allows you to record telephone conversations with a push of a single button. In the RECORD mode, the selected Send input audio is mixed with Caller audio and is sent to balanced and unbalanced RECORD/MIX audio outputs which can be used to feed both sides of the telephone conversation to a tape recorder.

Remote connections are provided to automatically start, enable record, and stop a tape recorder.

For broadcast applications, the CUE button selects either of two separate Send audio input sources. It toggles between MAIN SEND (normal console mix-minus send) and CUE SEND (usually the announcer's microphone preamplifier output). The selected source is routed to the caller and the RECORD/MIX output. MAIN SEND and CUE SEND inputs have individual level controls.

The use of console logic permits automatic switching between MAIN SEND and CUE SEND audio sources for on-the-air or off-the-air recording.

For audio conferencing applications, the CUE button legend is replaced with a legend engraved "HOLD". See Section 5.2 of this manual for instructions for changing the CUE button function to the HOLD button function.

Pressing the HOLD button will mute the Caller audio and select Send audio from the CUE SEND input. If a music-on-hold or other feed is desirable when the caller is on hold, it can be fed to the CUE INPUT on the rear panel of the SPH-5/5E.

The HOLD button toggles between two modes. Press it once and the HOLD button indicator comes on indicating the call has been placed on HOLD. Pressing the HOLD button a second time removes the call from hold to resume the conversation.

The switching between MAIN Send and CUE Send may also be programmed by the user to change the CUE SEND input to an AUXILIARY balanced send input. This will be summed with the MAIN SEND input at all times. Section 4.5 of this manual describes this option in detail.

The Gentner SPH-5/5E Telephone Hybrid provides these benefits:

- a) Excellent sound quality is delivered by the SPH-5/5E. The SPH-5/5E features analog audio for smooth, clear sounding conversations.
- b) Feedback and discoloration of Send audio are minimized, and hybrid isolation between the send and caller sides of telephone conversations is excellent.
- c) Band pass filters on both the Send and Caller circuits help to reduce hum, central office switching noise, and telephone multiplex distortion.
- d) Caller Control circuitry permits dimming (reducing) Caller audio by a variable amount when Send audio is present. This allows for a smooth interchange while maintaining announcer dominance.
- e) The SPH-5/5E provides connection muting which eliminates annoying pops and clicks when telephone calls are being connected.
- f) Remote Send or Receive muting. This permits placing a call on "hold", or muting Send audio for privacy.
- g) Selectable Frequency Extension (available on model SPH-5E only) improves telephone audio quality by digitally extending the low frequency response and reducing ambient noise level. This is an encode/decode process compatible with almost all single-line frequency extenders.

The Gentner SPH-5/5E Telephone Hybrid's ease of use and capabilities make it ideally suited for the following applications:

Radio and Television Talk Shows

- a) The Gentner SPH-5/5E provides excellent audio sound quality for all types of telephone call-in shows. It can be used on-air and off-air with equal ease.
- b) With Frequency Extension (available on model SPH-5E only) you take advantage of the cost effective convenience of direct dial lines while adding 2.5 octaves of audio bandwidth.
- c) Any applications where telephone calls are recorded for playback at a later time, or placed on the air directly are facilitated by the CUE and RECORD functions of the SPH-5/5E.
- d) Adjustable "Caller-Control" dims (reduces) received (Caller) audio to permit the desired degree of announcer dominance.

Audio Conferencing

- a) The Gentner SPH-5/5E Telephone Hybrid can be used in any Audio or Video Conferencing installation to provide high quality audio.
- b) "Cutoffs" and "Gating" are eliminated with the Gentner SPH-5/5E Telephone Hybrid. Full-duplex operation means simultaneous Send and Receive capabilities.
- c) The unit provides maximum intelligibility and audio quality.
- d) Using Frequency Extension with the SPH-5E, the audio quality is greatly improved due to extending the low-frequency response.
- e) Use it for return audio in Video Conferences, or for any high quality Audio Conference.
- f) The excellent performance characteristics of the Gentner SPH-5/5E help eliminate feedback in conferencing rooms.

1.3 Brief Technical Description

The SPH-5/5E is based on proven analog hybrid technology. This provides excellent, natural sound quality while maximizing the separation between the Send and caller sides of a telephone conversation.

Refer to **Figure 1**, **Figure 2**, and **Figure 3** while reading the following brief overview of the SPH-5/5E.

When the ON button is pressed, the SPH-5/5E activates a relay that connects the hybrid circuitry to the telephone line.

Through the internal hybrid circuitry, the Caller audio is separated from the Send audio. The CALLER OUTPUT appears on the rear panel. A mixture of Caller and Send audio is available at the RECORD/MIX OUTPUT connector on the rear panel.

When the EXTEND button is pressed (model SPH-5E only), Send audio is routed to a built-in encoder. The audio frequencies are shifted upward into the most linear and noise free band of standard telephone lines. At the same time, Caller audio is routed to a built-in decoder where audio frequencies are shifted downward.

NOTE: Since this Frequency Extension utilizes a complimentary frequency shift, an encode/decode device must be used at both Send and Caller ends of the telephone lines. (Gentner's digital Frequency Extension is fully compatible with most single-line frequency extenders.)

When the OFF button is pressed, the SPH-5/5E disconnects the telephone line and illuminates the OFF button indicator.

In broadcasting applications, the CUE button selects either MAIN Send, (normal console mix-minus send), or CUE Send, (usually the announcer's microphone preamplifier output).

For audio conferencing applications, the CUE button legend is replaced with a legend engraved "HOLD".

Pressing the HOLD button mutes the incoming caller's audio and either mutes or switches the source of Send audio (audio going to the caller) from the MAIN SEND input to the CUE SEND input.

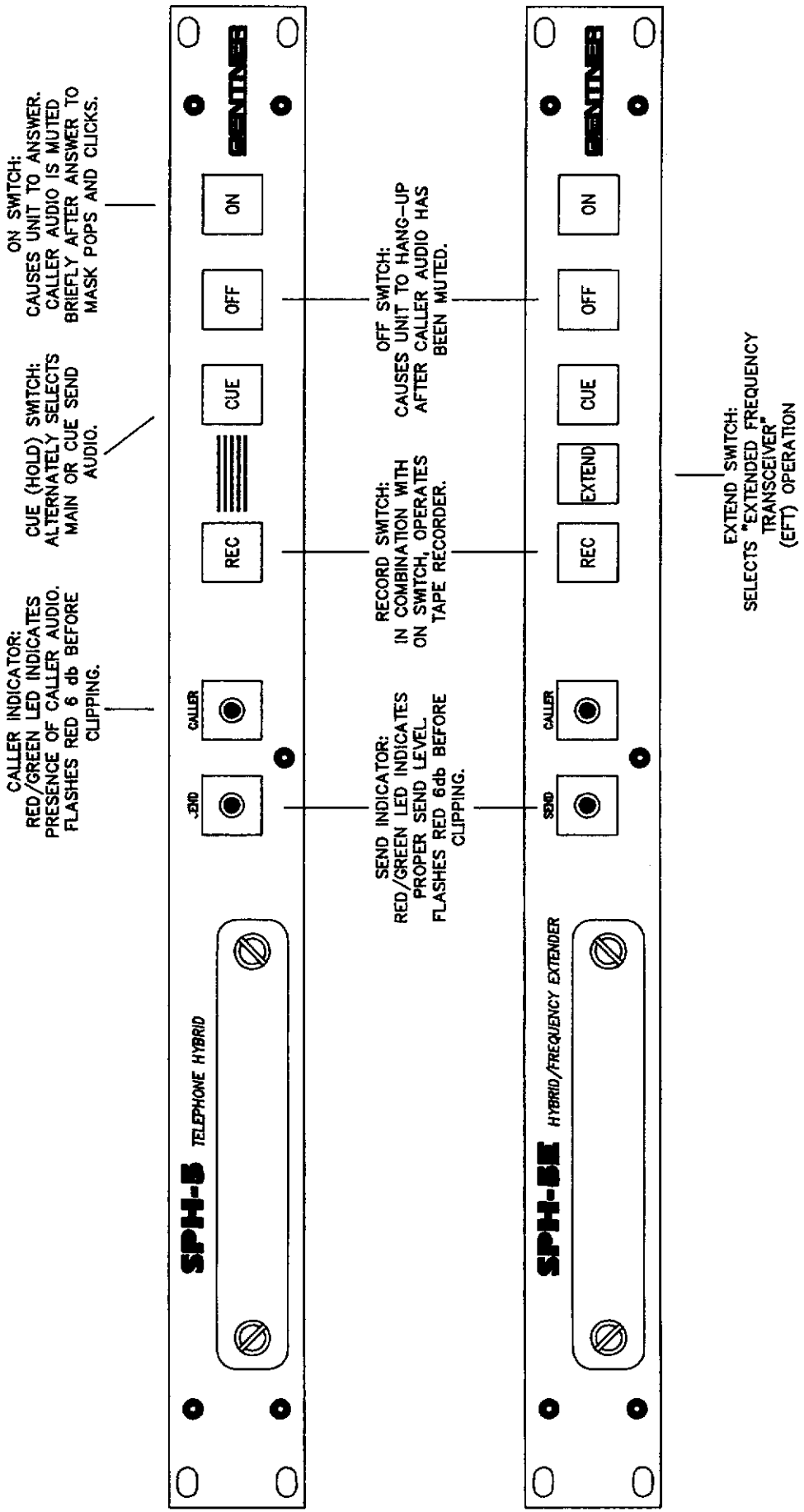

SPH-5/5E
"FRONT PANEL FUNCTIONS"

Figure 1

POWER SUPPLY:
100--120/220--240 VAC
OPERATION.

REMOTE CONTROL:
REMOTE CONNECTOR INCLUDES
REMOTE CONTROL AND AUDIO
CONNECTIONS

RECORD/MIX OUTPUT:
CONTAINS BOTH SEND AND
CALLER AUDIO.

MAIN INPUT:
MAIN SEND LINE
LEVEL INPUT.
WHEN SELECTED, THIS
AUDIO IS SENT TO
THE CALLER.

TELCO SET:
CONNECT TELEPHONE
SET HERE.

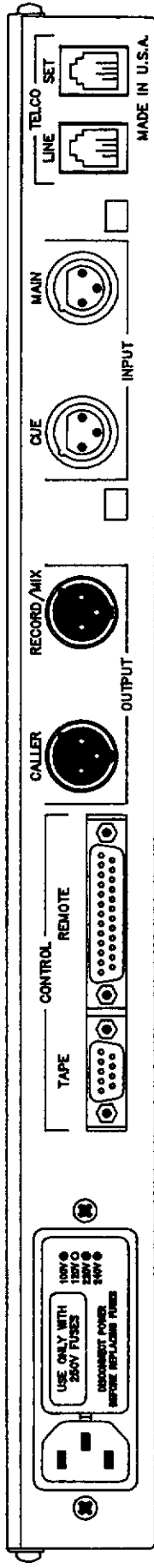

TAPE CONTROL:
TAPE CONNECTOR INCLUDES
RELAY CONTACT CONNECTIONS
TO TAPE RECORDER.

CALLER OUTPUT:
CONTAINS CALLER
AUDIO ONLY.

CUE INPUT:
CUE SEND LINE LEVEL INPUT.
WHEN SELECTED, THIS AUDIO
IS SENT TO THE CALLER.

TELCO LINE:
CONNECT TELEPHONE
LINE HERE.

SPH-5/5E
"REAR PANEL SUMMARY"

Figure 2

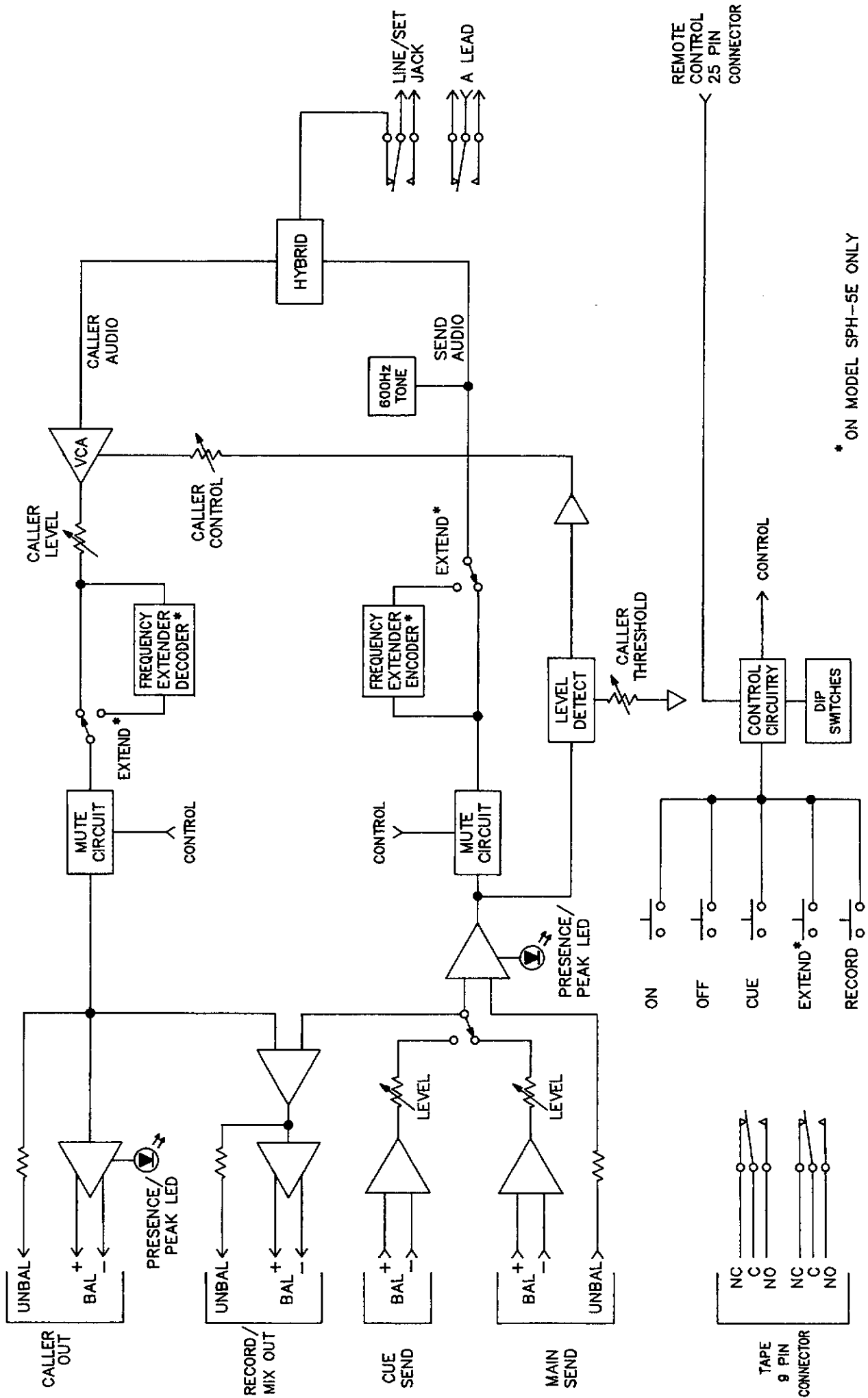

* ON MODEL SPH-5E ONLY

SPH-5/5E
FUNCTIONAL BLOCK DIAGRAM
Figure 3

1.4 Physical Specifications

The SPH-5/5E is enclosed in a rugged metal case, which may be mounted in a standard 19" equipment rack. The actual physical dimensions of the unit are:

Height:	1.75"/4.5 cm
Width:	19.0"/48.3 cm
Depth:	11.0"/28 cm
Weight (dry):	8 lbs/3.6 kg
Shipping weight:	12 lbs/5.5 kg

1.5 Electrical Specifications

- a) Power Requirements: 100-120/220-240 VAC; 50/60 Hz; 15 watts maximum.
- b) Temperature Range: 0 to +50 degrees Centigrade.

Telephone Interface

- a) LINE Connection: Modular RJ-11C
- b) External SET: Modular RJ-11C (The LINE jack is connected to the SET jack when the unit is off.)
- c) Common Mode Protection: Intentional path to ground at > 230 volts on tip or ring.
- d) Hybrid: Dual transformer analog hybrid.
- e) Key Service Compatibility: Any key system providing true tip and ring compatibility to telephone instruments.
- f) Tip/Ring Switching: Two Omron DPDT latching relays.

Telephone Transmit

All measurements are referenced to a +4 dBm input and a -15 dBm level to the telephone line.

- a) Send Distortion: < 0.1% THD, 270 to 3300 Hz
- b) Send SNR: > 65 db

Telephone Receive

All measurements are referenced to a -15 dBm telephone input and a +4 dBm output level.

- a) Receive Distortion: < 0.1% THD, 270 to 3300 Hz
- b) Receive SNR: > 65 dB

1.6 Audio Interface

- a) MAIN SEND Input: Actively balanced, XLR bridging input, +4 dBm nominal. Level is adjustable via front access panel trim-pot.
- b) CUE SEND Input: Actively balanced, XLR bridging input, +4 dBm nominal. Level is adjustable via front access panel trim-pot.
- c) AUXILIARY SEND Input: Unbalanced line level. Fixed unity gain. Pin 9 of REMOTE connector. This AUXILIARY SEND audio does NOT appear at the RECORD/MIX output.
- d) CALLER Output: Actively balanced, 600 ohm nominal output impedance. Nominal output level +4 dBm, clip level +20 dBm. Also 600 ohm UNBALANCED CALLER Output is available at Pin 10 of the REMOTE connector. Level is adjustable via front access panel trim-pot.
- e) RECORD/MIX Output: Actively balanced, 600 ohm nominal output impedance. +4 dBm nominal fixed output level. Also 600 ohm unbalanced RECORD/MIX output is available at Pin 11 of the REMOTE connector.

1.7 SPH-5/5E Rear Panel Connectors

The REMOTE connector is a 25-pin D-type connector located on the rear panel of the SPH-5/5E. See Section 3.12 for a more detailed description.

1 - Remote On	14 - ON Indicator ^a
2 - Remote Off	15 - OFF Indicator ^a
3 - Remote Record	16 - RECORD Indicator ^a
4 - Remote Cue (Hold)	17 - CUE Indicator ^a
5 - Switch Common ^b	18 - Indicator Common ^b
6 - Send Mute (Privacy)	19 - EXTEND Indicator ^{a *}
7 - Caller (Receive) Mute	20 - Remote EXTEND Switch [*]
8 - Remote Cue (Console)	21 - Not Used
9 - Unbalanced AUX Send	22 - AUX Send Audio Common ^c
10 - Unbalanced Caller	23 - Caller Audio Common ^c
11 - Unbalanced REC/MIX	24 - REC/MIX Audio Common ^c
12 - Aux Relay N.O.	25 - Aux Relay Common
13 - Aux Relay N.C.	

^a Open Collector Output

^b Digital Ground

^c Analog Ground

^{*} On Model SPH-5E Only

The TAPE connector is a 9-pin D-type connector located on the rear panel of the SPH-5/5E.

1 - N.O. Tape Start	6 - Tape Start Common
2 - N.C. Tape Start	7 - Record Enable N.C.
3 - N.O. Tape Stop	8 - Tape Stop Common
4 - N.C. Tape Stop	9 - Record Enable Common
5 - Record Enable N.O.	

Format for the XLR audio connectors:

Pin 1 GROUND

Pin 2 Audio -

Pin 3 Audio +

Pin-out of LINE and SET telephone connectors:

LINE RJ-11C

- 1 - To pin 6 of SET
- 2 - A-Lead Closure
- 3 - Tip
- 4 - Ring
- 5 - A-Lead Closure
- 6 - To pin 1 of SET

SET RJ-11C

- 1 - To pin 6 of LINE
- 2 - A-Lead Closure
- 3 - Ring
- 4 - Tip
- 5 - A-Lead Closure
- 6 - To pin 1 of LINE

SECTION TWO -- WARRANTY INFORMATION AND NOTICES

2.1 Warranty Agreement

The Gentner Warranty Agreement on the following page is effective as of the date of receipt by the purchaser of the SPH-5/5E Telephone Hybrid. This warranty shall not be effective unless Gentner is notified in writing by the purchaser of the receipt of the unit and the unit's serial number.

You have been supplied with a Gentner Warranty Registration Card. Use this card to notify Gentner of your purchase of the SPH-5/5E Telephone Hybrid and the serial number of your unit.

WARRANTY

GENTNER COMMUNICATIONS CORPORATION (Manufacturer) warrants that this product is free of defects in both materials and workmanship. Should any part of this equipment be defective, Manufacturer agrees, at its option, to:

A. Repair or replace any defective part free of charge (except transportation charges) for a period of one year from the date of the original purchase, provided the owner returns the equipment to the Manufacturer at the address set forth below. No charge will be made for parts or labor during this period;

B. Furnish replacement for any defective parts in the equipment for a period of one year from the date of original purchase. Replacement parts shall be furnished without charge, except labor and transportation.

This Warranty excludes assembled products not manufactured by Manufacturer whether or not they are incorporated in a Manufacturer product or sold under a Manufacturer part or model number.

THIS WARRANTY IS VOID IF:

A. The equipment has been damaged by negligence, accident, act-of-God or mishandling, or has not been operated in accordance with the procedures described in the operating and technical instructions; or,

B. The equipment has been altered or repaired by other than Manufacturer or an authorized service representative of Manufacturer; or,

C. Adaptations or accessories other than those manufactured or provided by Manufacturer have been made or attached to the equipment which, in the determination of Manufacturer, shall have affected the performance, safety or reliability of the equipment; or,

D. The equipment's original serial number has been modified or removed.

NO OTHER WARRANTY, EXPRESS OR IMPLIED, INCLUDING WARRANTY OF MERCHANTABILITY OR FITNESS FOR ANY PARTICULAR USE, APPLIES TO THE EQUIPMENT, nor is any person or company authorized to assume any warranty for Manufacturer or any other liability in connection with the sale of Manufacturer's products.

Manufacturer does not assume any responsibility for consequential damages, expenses or loss of revenue or property, inconvenience or interruption in operation experienced by the customer due to a malfunction in the purchased equipment. No warranty service performed on any product shall extend the applicable warranty period.

In case of unsatisfactory operation, the purchaser shall promptly notify Manufacturer at the address set forth below in writing, giving full particulars as to the defects or unsatisfactory operation, upon receipt of such notice, Manufacturer will give instructions respecting the shipment of the equipment, or such other matters as it elects to honor this warranty as above provided. This warranty does not cover damage to the equipment during shipping and Manufacturer assumes no responsibility for such damage. All shipping costs shall be paid by customer.

This warranty extends only to the original purchaser and is not assignable or transferable.

Gentner

GENTNER COMMUNICATIONS CORPORATION

1825 West Research Way

Salt Lake City, Utah 84119

Telephone: (801) 975-7200

Facsimile: (801) 977-0087

2.2 Special Notices

The information contained in this manual is subject to change without notice. Gentner Electronics Corporation makes no warranty of any kind with regard to this material including, but not limited to, the implied warranties of merchantability and fitness for a particular purpose. Gentner Electronics Corporation shall not be liable for errors contained herein or for incidental or consequential damages in connection with the furnishing, performance, or use of this material.

The copyright on this manual is held solely by Gentner Electronics Corporation.

Copyright (c) 1990 Gentner Electronics Corporation.

2.3 Product Line Updates

Gentner Electronics will offer new options and accessories for its products from time to time. All such updates will be available to you after you have completed and returned the Warranty Card enclosed with this product.

If your card is lost, you may notify Gentner by letter. Please include the following information:

- a) The Serial Number
- b) Your Name
- c) The Name of your Organization
- d) Your Address
- e) Date of Purchase
- f) Name of Dealer

Mail your Warranty Registration Card to:

Gentner Electronics Corporation
P.O. Box 27647
Salt Lake City, Utah 84127-0647

SECTION THREE -- INSTALLATION

3.1 Unpacking Your SPH-5/5E Telephone Hybrid

Carefully unpack your shipment and check for any damage. Be sure that all the parts listed in Section 1.1 of this manual are included in your package.

If you notice any damage to the unit, notify your shipping carrier immediately. Be sure to retain the original boxes and packing material for inspection by the carrier. Gentner is not responsible for shipping damage. You must make damage claims directly with the carrier.

3.2 Mounting Your SPH-5/5E Telephone Hybrid

You can mount the SPH-5/5E into a standard 19" equipment rack if desired.

The SPH-5/5E does not require an internal cooling fan. As long as the unit receives adequate ventilation, it will operate normally.

Gentner recommends an operating environment between 0 and +50 degrees Centigrade.

Be careful not to block any of the ventilation holes in the unit's chassis. Always be sure that a free flow of air gets to the unit while it is operating.

You can also mount the SPH-5/5E into a road case, making it easy to transport and protect from the elements.

If you install your SPH-5/5E into a road case, you should ensure that your SPH-5/5E receives adequate ventilation during operation.

3.3 Setting Up the AC Power Input

CAUTION: Always be sure that the SPH-5/5E Telephone Hybrid is configured for the correct power source prior to operation.

Your SPH-5/5E Telephone Hybrid was shipped to you ready to use with a 100-120 VAC 50/60 Hz power source (unless otherwise marked.) You can easily alter the AC power input to accept 220-240 VAC power input.

To change the operating voltage for the SPH-5/5E, please refer to **Figure 4** while reading the instructions below:

- a) **DISCONNECT THE UNIT FROM AC POWER.** Unplug the electrical power cable from the rear panel.
- b) Use a small screwdriver to remove the black access cover from the rear-panel fuse/power assembly.
- c) Use long-nosed pliers to pull on the nylon tab located near the right side of the assembly and remove the small square jumper board.
- d) Reposition the jumper board so the imprinted designation of the desired voltage faces away from the nylon tab.
- e) Re-insert the jumper board oriented so that the desired voltage imprint is away from you and the nylon tab is toward you.
- f) Replace the fuse with the proper value as indicated below:

For 100-120 VAC, the fuse should be 1/4 amp Slo-Blo.

For 220-240 VAC, the fuse should be 1/8 amp Slo-Blo.
- g) Replace the black access cover.
- h) The tip of the nylon tab should indicate the selected voltage as inscribed on the black access cover.
- j) Replace the power cable and proceed with installation.

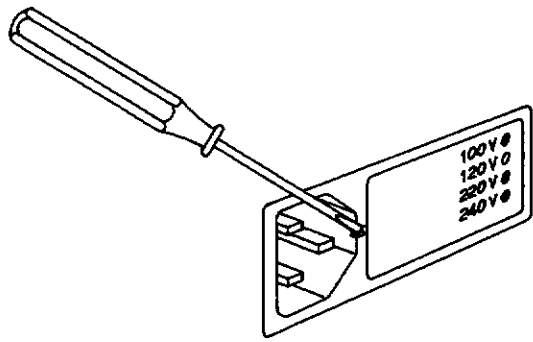

REMOVE COVER PANEL USING
SMALL SCREW DRIVER OR
SIMILAR TOOL.

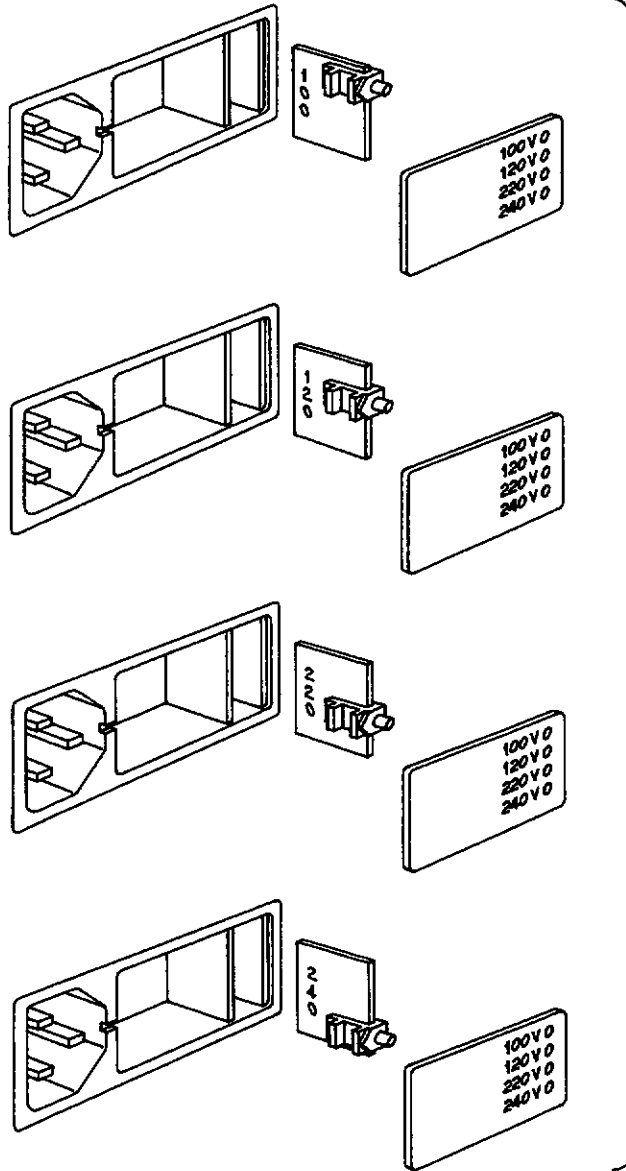

PULL VOLTAGE SELECTION CARD
FROM ITS HOUSING AND ROTATE
AS SHOWN TO PLACE PLASTIC
INDICATOR TAB IN THE REQUIRED
POSITION FOR THE DESIRED
VOLTAGE.

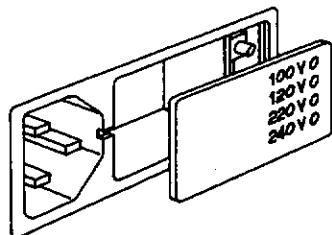

PUSH VOLTAGE SELECTION CARD
BACK INTO ITS HOUSING AND
REPLACE COVER PANEL.

SETTING UP THE AC POWER INPUT

Figure 4

3.4 Connecting the SPH-5/5E Directly to a Single Central Office Telephone Line

Connect the incoming telephone line to the SPH-5/5E's LINE jack with the appropriate modular telephone cable. Refer to **Figure 5** for details.

An optional telephone instrument can be connected to the SET jack. Telephone calls can be placed and received normally with the telephone instrument when the SPH-5/5E is in the OFF condition.

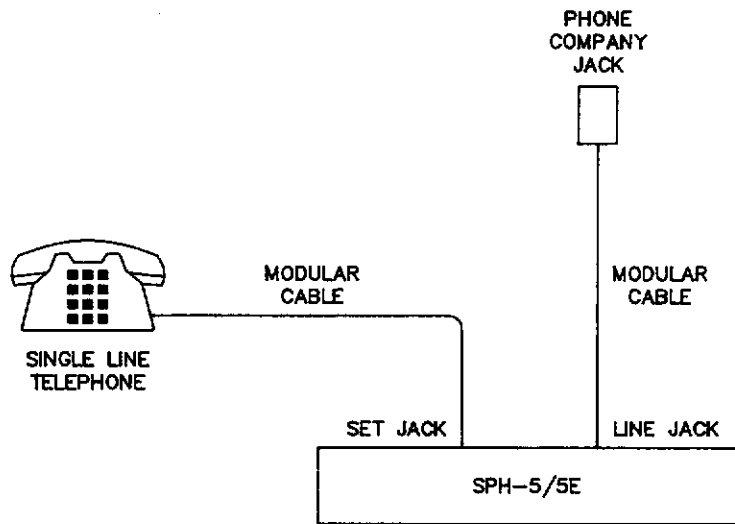

CONNECTION TO A SINGLE CENTRAL OFFICE TELEPHONE LINE

Figure 5

3.5 Connecting the SPH-5/5E Telephone Hybrid to a 1A2 Key Service Unit

The SPH-5/5E may be used in conjunction with an existing 1A2 key service unit in one of three ways:

- a) Using an existing multi-line telephone set as a call director. See Section 3.6 for a detailed discussion.
- b) Using an existing Gentner Telemix IX as a call director. See Section 3.7 for detailed information.
- c) Using a Gentner Telemix X as a call director. See Section 3.8 for detailed information.

Detailed instructions for using the SPH-5/5E in each of these ways are given in the sections indicated. Please take the time to carefully study them.

3.6 Using the SPH-5/5E with an Existing Multi-Line Telephone Set

Refer to **Figure 6** while reading the following information.

When using an existing multi-line telephone set, the buttons on the set can provide the necessary line selection function for the SPH-5/5E.

Remove the telephone's cover and locate the common Tip and Ring connections that go from the line selector button array to the telephone electronics network. Sever this connection, as shown in **Figure 6**.

Connect the Tip and Ring wires coming from the line selector button array to the red and green conductors of a modular cable.

The yellow and black conductors provide the A-lead closure and should be connected to the common A-lead that is normally found at the telephone hook switch.

This modular cable can now be connected to the LINE jack on the SPH-5/5E.

The red and green conductors of a second modular cable should be connected to the severed Tip and Ring of the telephone electronics network as indicated in **Figure 6**. The yellow and black conductors of this cable should be left unconnected.

This second cable should be connected to the SET jack on the SPH-5/5E.

This installation will allow the multi-line instrument to operate normally when the SPH-5/5E is OFF line.

When the SPH-5/5E is placed ON line, it will provide the necessary A-lead closure to light the selected line and it will automatically disconnect the telephone instrument's electronics network.

It is not possible to specify wire colors or terminal numbers for 1A2 telephone equipment in this manual due to the wide variety of telephone instruments and manufacturers of 1A2 equipment.

Additional help may be obtained by contacting your telephone interconnect company or Gentner Customer Support.

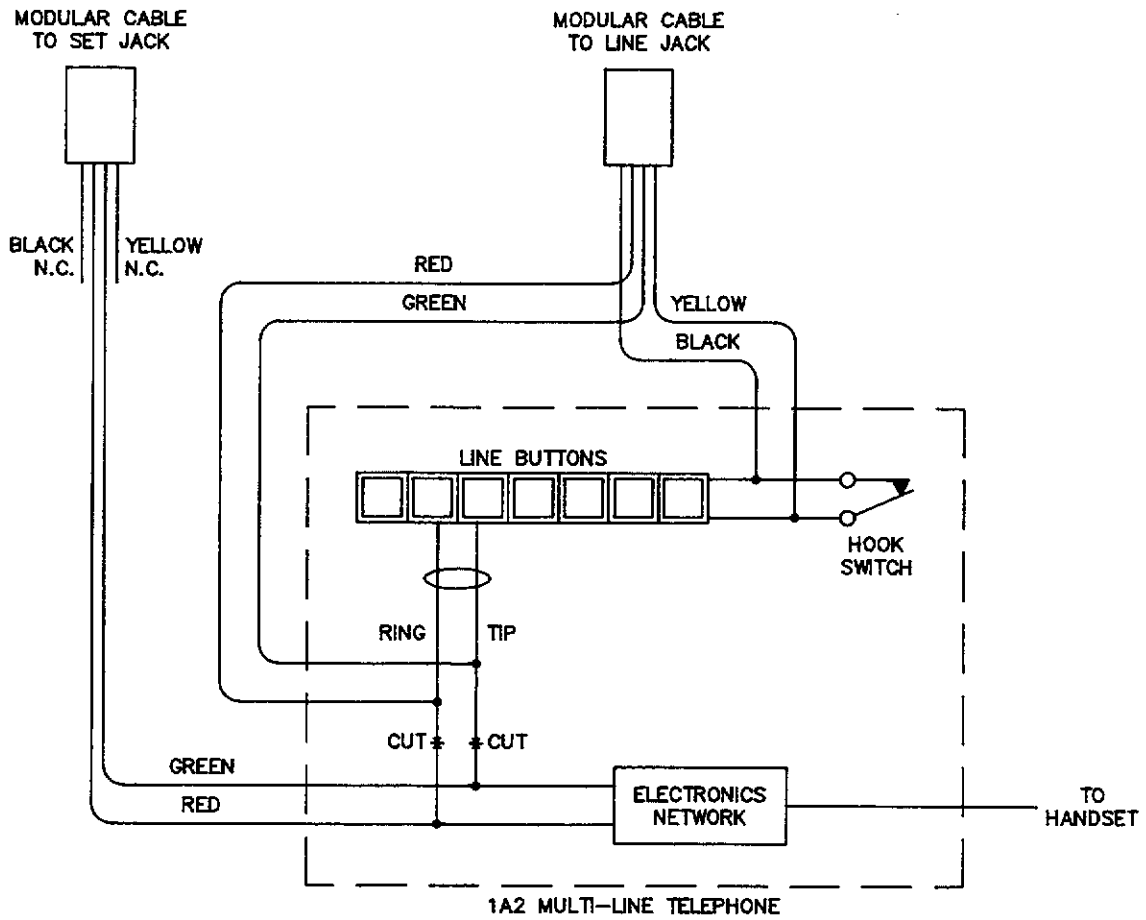

CONNECTION TO A MULTI-LINE TELEPHONE SET

Figure 6

3.7 Using a Gentner Telemix IX as a Call Director

A simple method of connecting a SPH-5/5E to a Telemix IX uses one modular telephone cable.

Strip one end of the cable and connect spade lugs to the red and green wires. Attach these wires to the Telemix IX rear barrier strip as follows:

- a) To use the SPH-5/5E on the upper bus (lines 1 through 9), connect to barrier strip Pin 1 and Pin 2. Or, to replace the lower bus hybrid with the SPH-5/5E, connect to barrier strip Pin 3 and Pin 4.
- b) Plug the other end of the modular cable into the SPH-5/5E's LINE jack.

NOTE: Two external hybrids are required to replace the hybrids in the Telemix IX system. Any combination of hybrids may be used.

Open the Telemix IX and locate the Mascon connector on the audio board that routes to the rear panel barrier strip.

Four jumpers are located on the audio board near this connector. These jumpers route Tip and Ring to the internal hybrids. Removal of the plug-in jumpers will disconnect the internal hybrids and allow external control via SPH-5/5E's.

In the Telemix IX system, conferencing of upper and lower bus callers is accomplished on the audio board. When the internal hybrids are defeated, the system will no longer provide bus conferencing.

Bus conferencing is then done by cross-connecting the external hybrids. Refer to Section 6.2 for instructions on conferencing multiple SPH-5/5E Telephone Hybrids.

When the Telemix IX is used with external hybrids, the SPH-5/5E Hybrids are left in the ON position. In this configuration, a slight 'pop' will be heard in the audio when a line is placed on hold or disconnected.

3.8 Using a Gentner Telemix X as a Call Director

Connection of single or dual SPH-5/5E hybrids to a Gentner Telemix X is very easy.

If the SPH-5/5E's were ordered in conjunction with Telemix X, all necessary interconnect cables should have been provided with the system:

- a) The Universal Call Director cable.
Gentner Part Number 830-004-001.
- b) The SPH-5/5E Telephone Hybrid interface cable.
Gentner Part Number 830-004-008.
(One required for each SPH-5/5E to be utilized).

Simply connect the 25-pin connector on the Universal Call Director cable to its mating connector marked **HYBRID** on the rear panel of the Telemix X Call Director.

Connect the small Molex connector marked **HYBRID 1** on the Universal Call Director cable to the Molex connector on one end of a SPH-5/5E Interface cable.

Plug the 25-pin connector on the opposite end of the interface cable onto the **REMOTE** connector of the SPH-5/5E.

Connect the second hybrid in the same manner, using the small Molex connector marked **HYBRID 2**.

NOTE: If only one SPH-5/5E Telephone Hybrid is to be used with the Telemix X system, the second Molex connector on the Universal Interface Cable is simply left unconnected, and **DIP Switch 1** on the Telemix X is placed in the **down** position (One Hybrid Enable).

Figure 7 shows the Universal cable assembly interfacing two SPH-5/5E's with the single Gentner Telemix X Call Director system.

In dual Call Director systems, a few more connections are required to setup the system. **Figure 8** shows the dual Call Director system using four SPH-5/5E's.

The six-pin Molex connectors on the Interface Cable provide remote control logic connections, and supply telephone Tip and Ring to the RJ-11C LINE connector on the rear panel of the SPH-5/5E Telephone Hybrid.

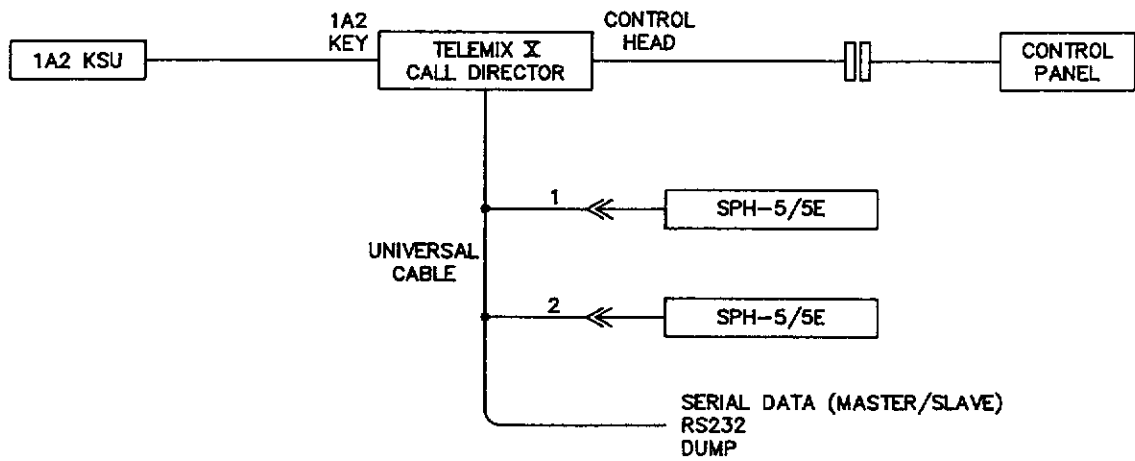

CONNECTION TO A SINGLE TELEMIX X CALL DIRECTOR

Figure 7

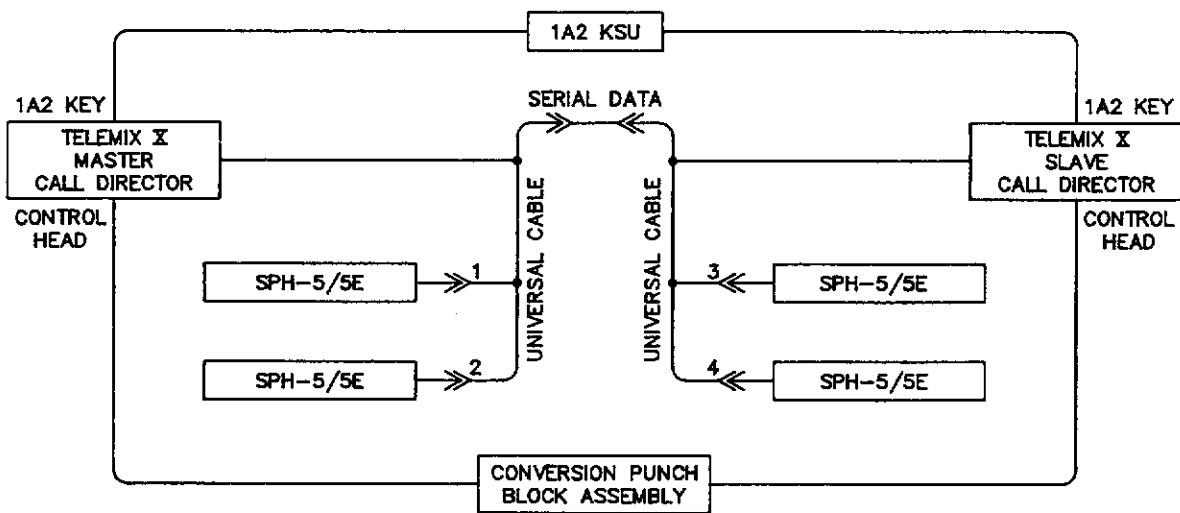

CONNECTION TO A DUAL TELEMIX X CALL DIRECTOR

Figure 8

The Call Director must be able to control the ON, OFF and MUTE functions of the SPH-5/5E. The following table describes the interconnections between the Telemix X and two SPH-5/5E's, as provided by the Universal Interface Cable and the SPH-5/5E interface cable(s):

<u>TELEMIX X</u> (DB-25)	<u>FUNCTION</u>	<u>FIRST SPH-5/5E</u> <u>INTERFACE CABLE</u>	
		(Molex)	(DB-25)
8	First SPH-5/5E Hybrid ON	1	1
9	First SPH-5/5E Hybrid OFF	2	2
19	Ground	3	5
10	First SPH-5/5E Hybrid MUTE	4	7
22	Tip Bus A	5	(To LINE RJ-11C-3)
23	Ring Bus A	6	(To LINE RJ-11C-4)

<u>TELEMIX X</u> (DB-25)	<u>FUNCTION</u>	<u>SECOND SPH-5/5E</u> <u>INTERFACE CABLE</u>	
		(Molex)	(DB-25)
7	Second SPH-5/5E Hybrid ON	1	1
12	Second SPH-5/5E Hybrid OFF	2	2
19	Ground	3	5
11	Second SPH-5/5E Hybrid MUTE	4	7
24	Tip Bus B	5	(To LINE RJ-11C-3)
25	Ring Bus B	6	(To LINE RJ-11C-4)

For additional installation information, please refer to the Gentner Telemix X User's Manual.

3.9 Compatibility with Electronic KSU Telephone Sets

Many broadcast facilities and offices employ telephone equipment that uses microprocessor controlled key service units. Even though these systems are referred to as digital, the actual audio to the multi-line telephone instrument is often carried on an analog balanced pair.

Such systems can usually be satisfactorily interfaced to the SPH-5/5E Telephone Hybrid. It is recommended that you contact your interconnect company and inquire if they offer units (often called "jack sets" or "modem interface units" or "Tip and Ring equivalent jacks") that bring out the necessary connections for interface to the SPH-5/5E.

Your interconnect company may also be able to tell you if the audio is digital or analog and if there is DC on the audio pair. This information will be needed to accomplish the procedure described in Section 3.10.

Asking for a "line that a FAX machine can be connected to" or "a line that a telephone answering machine can be connected to" will usually solve any problems in getting the right connections for a SPH-5/5E from an electronic key service system.

3.10 Connecting the SPH-5/5E to an Electronic Key Service Telephone Set

Refer to **Figure 9** while reading the next few paragraphs.

Because of the large number of manufacturers and wide variety of equipment available, this discussion can only give a general overview of how to interface the SPH-5/5E Telephone Hybrid to electronic key service systems.

Most digital telephones connect to the key service unit with either a four or six wire modular connection cable.

Unplug this cable from the telephone and carefully remove the set's cover.

Locate the wires coming from the KSU connector. Two of these wires will be the analog pair mentioned in Section 3.9.

In most digital telephones, this analog pair is found to be the red and green wires. (The remaining wires are used for telephone power, intercom and microprocessor communications.)

The analog pair can be verified by connecting a pair of high impedance headphones through 10 uF capacitors across the suspected analog pair. With the headphones connected as just described, the telephone instrument can then be connected to the KSU (plug in the cable) and a line selected. If dial tone is heard in the headphones, the analog pair has been located.

Sever this pair between the jack and the electronics of the telephone as indicated in **Figure 9**. Frequently DC is found on the audio pair which is used to power the telephone set. This can be verified if the set goes dead when this pair is severed. If DC is present on the audio pair, it can be isolated using the hookup shown in **Figure 10**. For a more detailed discussion, please see Appendix A of this manual.

Please refer again to **Figure 9**. Prepare two telephone cables with modular connectors on one end of each cable. Make sure the cables have sufficient length to reach from the normal location of the telephone to the location of the SPH-5/5E.

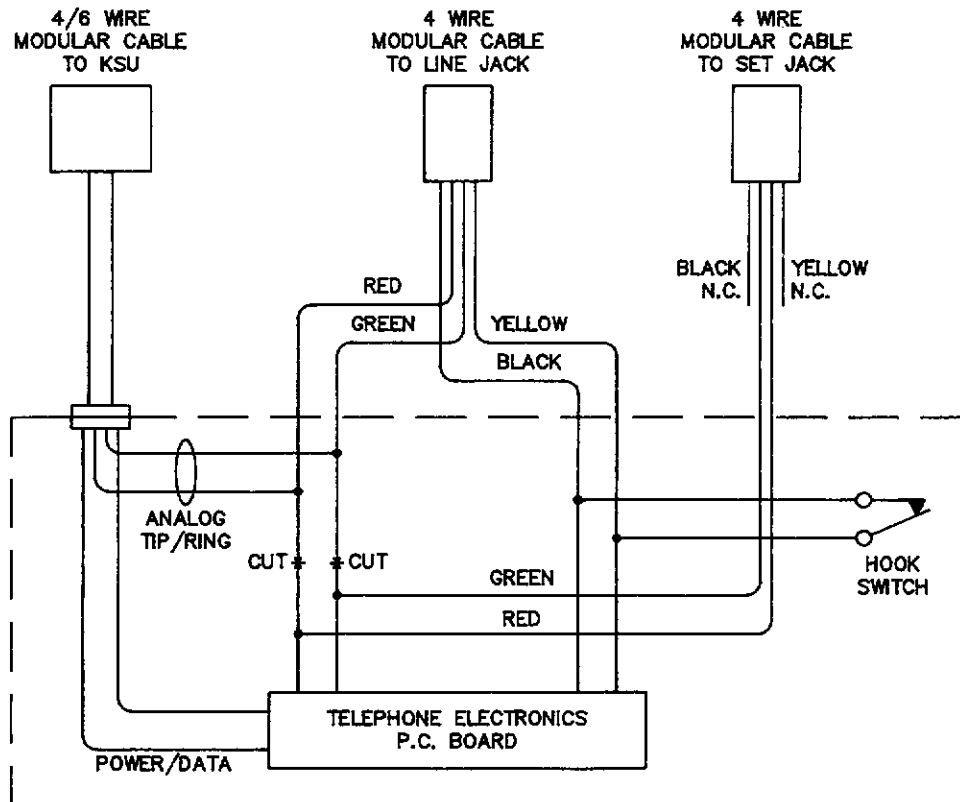

CONNECTION TO DIGITAL TELEPHONES

Figure 9

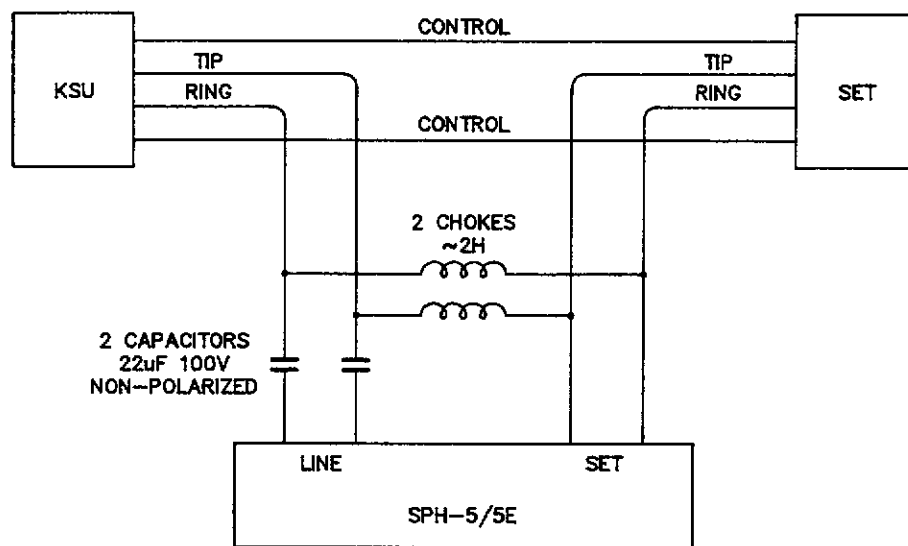

INSTALLATION IN A DIGITAL TELEPHONE SYSTEM
WITH DC ON THE AUDIO PAIR

Figure 10

Connect the red and green wires of one of these cables to the analog pair coming from the KSU jack of the telephone set. Connect the yellow and black wires of this cable in parallel with the hook switch contacts of the digital telephone.

This cable connects to the LINE jack on the SPH-5/5E.

Connect the red and green wires of the second modular cable to the analog pair going to the electronics of the telephone set. (The yellow and black wires of this cable are left unconnected.) This cable connects to the SET jack of the SPH-5/5E.

The telephone instrument can now be re-assembled and reconnected to the KSU by plugging its cable back in.

The configuration just described allows the digital telephone set to be used normally when the SPH-5/5E is OFF line.

When the SPH-5/5E is ON line, the analog path to the telephone electronics is automatically disconnected and the hook switch connection is closed. This allows line selection to be made on the telephone without having to lift the handset.

Other methods of interfacing to multi-line telephones are available. Gentner Electronics Corporation continues to gain experience in interfacing our line of telephone products to an ever-expanding list of digital telephone systems. Contact your telephone system manufacturer or Gentner Customer Support if you need further assistance.

3.11 Connecting the SPH-5/5E to Audio Equipment

The basic function of the SPH-5/5E Telephone Hybrid is to separate audio being sent to the caller (Send audio) from audio being received from the caller (Caller audio). Please refer to **Figure 11**.

The primary audio connections for the SPH-5/5E are made via XLR connectors and include MAIN SEND input, CUE SEND input, CALLER audio output and RECORD/MIX audio output. Please refer to **Figure 12**.

The MAIN SEND and the CUE SEND inputs are balanced, bridging line level inputs. Only one of these inputs is selected for use at a time. This selection is dependent on the status of the CUE (HOLD) function.

The RECORD/MIX audio output provides a balanced, line level sum of the selected audio (MAIN or CUE), and Caller audio.

The CALLER out is Caller audio only. It is a balanced line level output.

Additional unbalanced audio inputs and outputs are found on the DB-25 REMOTE connector.

If a mixing console will be used to feed the MAIN or CUE inputs of the SPH-5/5E, the audio going down the line must not contain any Caller audio. There are several ways to accomplish this:

- a) Creation of a separate mix channel. If the console has an extra mixing output channel, use this channel to mix all audio you want to send to the SPH-5/5E, EXCEPT the channel that will be connected to Caller audio.
- b) Internal mix-minus bus. Mix-minus refers to a sum of all the audio sources in the console MINUS the Caller audio. Many console manufacturers provide this feature.
- c) "Build Your Own" mix-minus by summing all audio sources to be sent to the caller.

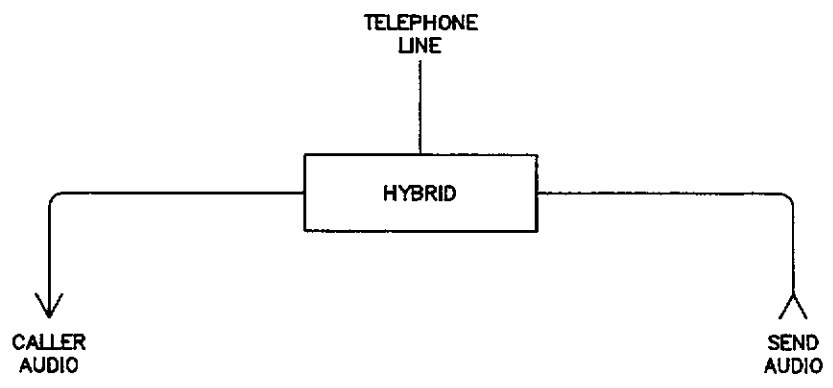

FUNCTION OF A TELEPHONE HYBRID

Figure 11

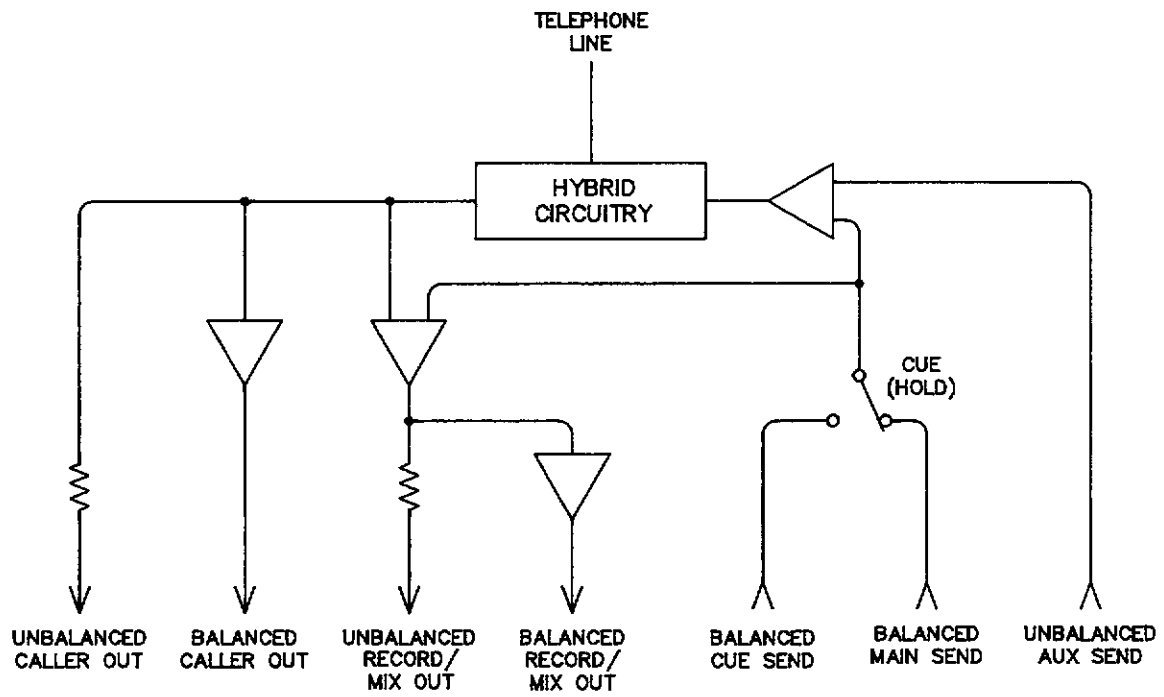

SPH-5/5E
AUDIO CONNECTIONS

Figure 12

- d) **Discrete Microphone Mixer.** If only microphone audio will be sent down the line, a separate microphone mixer may be utilized. This audio can then be sent to either input of the SPH-5/5E Telephone Hybrid as well as the input of the console.
- e) **One Channel Send.** If a single source of audio will be sent to the caller (such as a microphone), simply use the line-level output of the microphone preamplifier.

The CALLER output XLR must be connected to a separate channel of an audio console or the input of an audio amplifier. This will allow monitoring of Caller audio.

The RECORD/MIX output XLR contains a sum of both Send and Caller audio. This audio combination is useful for recording both sides of telephone conversations.

3.12 The REMOTE Connector

The REMOTE connector is a 25-pin D-type connector located on the rear panel of the SPH-5/5E Telephone Hybrid. The following is a pin-out of remote control functions and audio connections that appear on the REMOTE connector:

1 - Remote On	14 - ON Indicator ^a
2 - Remote Off	15 - OFF Indicator ^a
3 - Remote Record	16 - RECORD Indicator ^a
4 - Remote Cue (Hold)	17 - CUE Indicator ^a
5 - Switch Common ^b	18 - Indicator Common ^b
6 - Send Mute (Privacy)	19 - EXTEND Indicator ^{a*}
7 - Caller (Receive) Mute	20 - Remote EXTEND Switch [*]
8 - Remote Cue (Console)	21 - Not Used
9 - Unbalanced AUX Send	22 - AUX Send Audio Common ^c
10 - Unbalanced Caller	23 - Caller Audio Common ^c
11 - Unbalanced REC/MIX	24 - REC/MIX Audio Common ^c
12 - Aux Relay N.O.	25 - Aux Relay Common
13 - Aux Relay N.C.	

^a Open Collector Output

^b Digital Ground

^c Analog Ground

^{*} On Model SPH-5E Only

When looking at the REMOTE connector on the rear panel of the SPH-5/5E, Pin 1 through Pin 13 appear left to right on the top row of pins. Pin 14 through Pin 25 appear left to right on the bottom row of pins. See **Figure 13**.

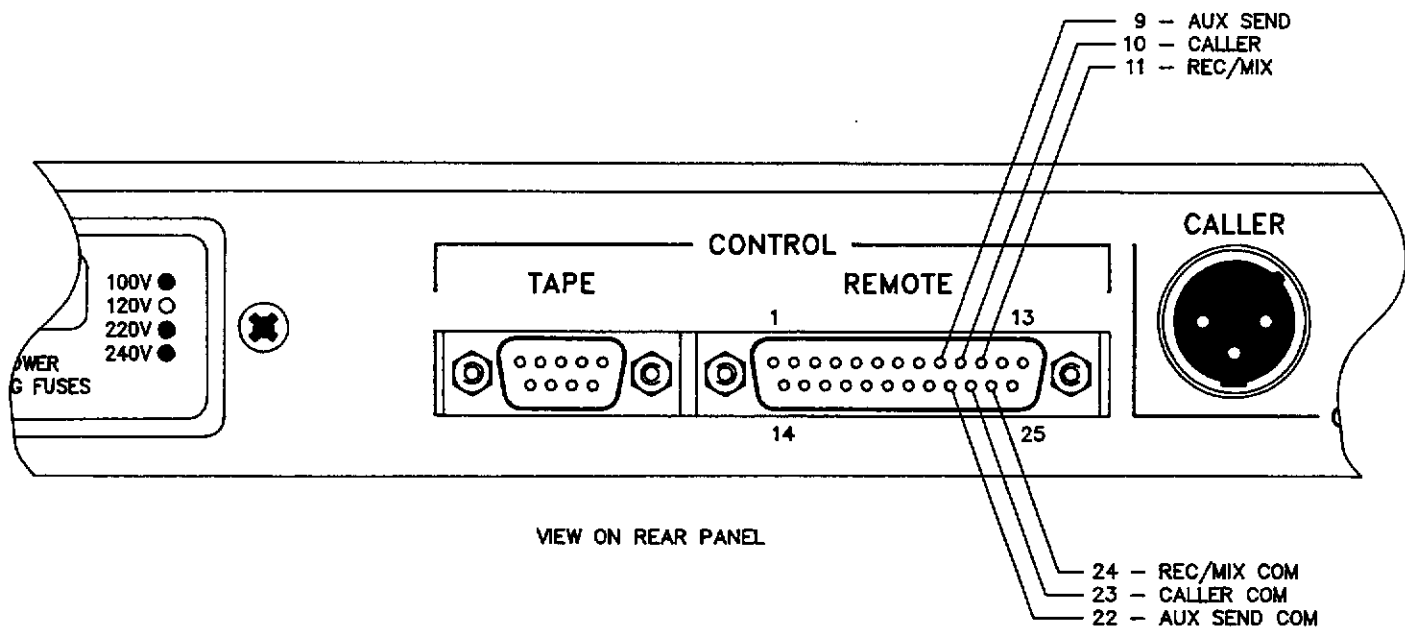

VIEW ON REAR PANEL

NOTE: AUDIO CONNECTIONS ON REMOTE CONNECTOR ARE UNBALANCED.

REMOTE CONNECTOR AUDIO PIN OUTS

Figure 13

A brief discussion of the functions of the pins on the DB-25 REMOTE connector follows:

Pin 1 Remote On
Pin 5 Switch Common

These connections are used to remotely turn the SPH-5/5E on. The switching action can be either momentary or latching, as selected by front panel DIP Switch 5. The SPH-5/5E is shipped with DIP Switch 5 in the **down** position. In this position, a momentary closure between REMOTE connector Pin 1 and Pin 5 will turn on the SPH-5/5E.

NOTE: If you choose to use the remote ON/OFF switching in the latching mode, the SPH-5/5E front panel ON/OFF buttons will not function normally.

Pin 2 Remote Off
Pin 5 Switch Common

A momentary closure between these pins turn off the SPH-5/5E Telephone Hybrid. This function is preempted if DIP Switch 5 is in the **up** position, causing the ON/OFF switching to be via latching closure of Pin 1 and Pin 5.

Pin 3 Remote Record
Pin 5 Switch Common

A momentary closure between these pins toggles alternately between the Normal and Record modes of operation. See Section 4.7 of this manual for a discussion of the Record function.

Pin 4 Remote CUE (Remote HOLD)

Pin 5 Switch Common

A momentary closure between these pins toggles alternately between CUE (Indicator illuminated) and normal operation.

NOTE: This remote CUE connection functions exactly like the front-panel CUE (HOLD) button, whereas the remote CUE (Console) connection provided at Pin 8 functions differently, requiring latching closure to enable the CUE function. See Section 4.7 for detailed explanation of the CUE (HOLD) function.

For **audio conferencing** applications, this closure will alternately select HOLD or normal.

NOTE: Installation of a jumper between Pin 7 and Pin 17 on the DB-25 REMOTE connector is required to provide Caller muting when HOLD is selected.

Pin 5 Switch Common

This is the common ground return for all remote switching functions. It is recommended that this return be the only ground reference used for this purpose.

Pin 6 Send Mute (Privacy Switch)

Pin 5 Switch Common

A closure between these pins will cause the SPH-5/5E Send audio to be muted. This must be a latching closure. This mute can be used as a "privacy" switch because the caller will not be able to hear anything when this function is active.

The CUE/HOLD button may be configured as a Privacy Switch by installing a jumper between Pin 6 and Pin 17. Closure between these pins causes Send audio to be muted.

Pin 7 Caller (Receive) Mute
Pin 5 Switch Common

A latching closure between these pins will cause the SPH-5/5E Receive audio to be muted.

Pin 8 Remote Cue (Console)
Pin 5 Switch Common

This remote Cue connection is intended to be interfaced with latching console logic closures. The Cue feature is enabled continually as long as the closure between these pins is provided, unless overridden by action of the front-panel CUE button or remote cue switch, Pin 4 of the REMOTE connector. See Sections 4.7 and 4.8 for more information.

Pin 9 Auxiliary Send +
Pin 22 Auxiliary Send Ground

This is an unbalanced AUXILIARY SEND audio input. These connections will be used when conferencing multiple SPH-5/5E's.

NOTE: Do not connect the inverted (-) audio signal from an actively balanced source to Pin 22, as this would place a direct short circuit across the inverting half of the source amplifier. Connection to the plus (+) audio signal with single ground-return path is all that is needed.

Pin 10 Unbalanced Caller +
Pin 23 Unbalanced Caller Ground

This is an unbalanced CALLER audio output. It can be use for applications requiring an additional unbalanced CALLER output.

Pin 11 Unbalanced RECORD/MIX Audio Output +
Pin 24 RECORD/MIX Ground

This provides an unbalanced RECORD/MIX audio output which may be used for a wide range of applications. For example, this output may be used to feed a tape recorder for recording telephone conversations.

Pin 12 Aux Relay N.O.
Pin 13 Aux Relay N.C.
Pin 25 Aux Relay Common

These pins provide access to the Auxiliary Relay contacts that follow the action of the ON/OFF switching functions. Pin 12 is normally open when the SPH-5/5E is in the OFF mode, and closes to Common when the hybrid is switched ON.

Pin 14 Remote ON Indicator
Pin 15 Remote OFF Indicator
Pin 16 Remote RECORD Indicator
Pin 17 Remote CUE Indicator

These pins are used to remote the ON, OFF, RECORD, and CUE indicators. Pin 14, Pin 15, Pin 16, and Pin 17 provide open collector outputs capable of sinking 100 mA at 40 VDC. An external voltage supply must be used to power the remote indicators. This supply must be referenced to Pin 18 and must not exceed 40 VDC. Also, the total current into each of these pins must not exceed 100 milliamps.

Pin 18 Indicator Common

Use this pin as the negative reference for the external power supply used to drive remote indicator lamps or LED's. See comments for Pin 14, Pin15, Pin 16, and Pin17 above.

Pin 19 EXTEND Indicator

This pin is only used on the SPH-5E and operates the remote EXTEND Indicator. It provides an open collector output capable of sinking 100 mA at 40 VDC. An external voltage supply must be used to power this remote indicator. This supply must be referenced to Pin 18 and must not exceed 40 VDC. Also, the total current must not exceed 100 milliamps.

**Pin 20 Remote EXTEND Switch
Pin 5 Switch Common**

Pin 20 is only used on the SPH-5E. A momentary closure between these pins toggles alternately between the Normal and Frequency Extension modes of operation.

Pin 21 Not Used

This pin is reserved for possible future use.

Additional information on remote control functions is given in Section 4.8 of this manual.

3.13 The TAPE Connector

The TAPE connector is a 9-pin D-type connector located on the rear panel of the SPH-5/5E Telephone Hybrid. The TAPE connector allows you to remotely control a tape recorder with the SPH-5/5E.

The following is a pin-out of remote control functions that appear on the TAPE connector:

- | | |
|------------------------|--------------------------|
| 1 - N.O. Tape Start | 6 - Tape Start Common |
| 2 - N.C. Tape Start | 7 - Record Enable N.C. |
| 3 - N.O. Tape Stop | 8 - Tape Stop Common |
| 4 - N.C. Tape Stop | 9 - Record Enable Common |
| 5 - Record Enable N.O. | |

When looking at the TAPE connector on the rear panel of the SPH-5/5E, Pin 1 through Pin 5 appear left to right on the top row of pins. Pin 6 through Pin 9 appear left to right on the bottom row of pins. See **Figure 14**.

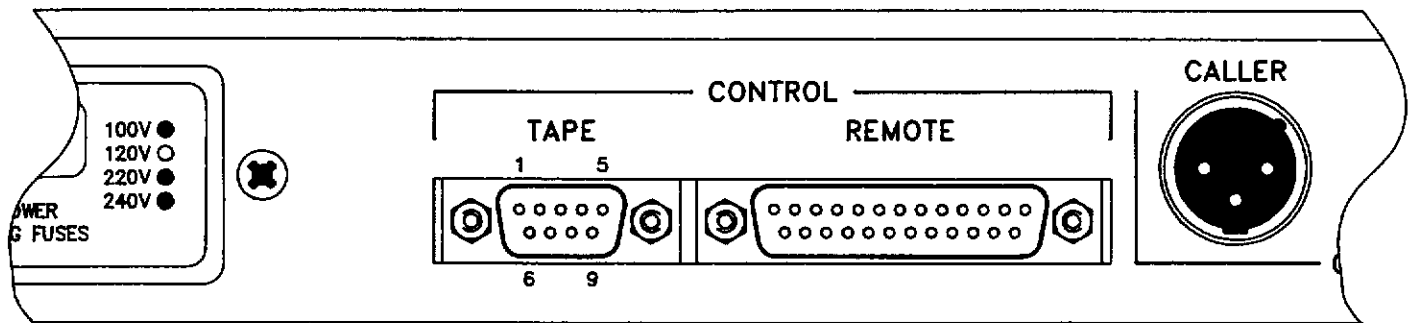

VIEW ON REAR PANEL

DB-9 TAPE CONTROL CONNECTOR PIN LOCATIONS

Figure 14

A brief discussion of each pin on this connector follows:

- Pin 1 N.O. Tape Start Relay Contact**
- Pin 2 N.C. Tape Start Relay Contact**
- Pin 6 Common Tape Start Relay Contact**

These connections provide dry contact closures for the tape start relay. Action of the relay is momentary when front panel DIP Switch 3 is in the **down** position, and latching with this DIP Switch in the **up** position. See Section 4.7 for a functional description of the RECORD feature.

- Pin 3 N.O. Tape Stop Relay Contact**
- Pin 4 N.C. Tape Stop Relay Contact**
- Pin 8 Common Tape Stop Relay Contact**

These connections provide dry contact closures for the tape stop relay. Action of the relay is momentary when front panel DIP Switch 4 is in the **down** position, and latching with this DIP Switch in the **up** position. See Section 4.7 for a functional description of the RECORD feature.

- Pin 5 N.O. Record Enable**
- Pin 7 N.C. Record Enable**
- Pin 9 Record Enable Common**

These connections provide dry contact closure for the record enable function of the tape recorder. Closure of these contacts follows that of the Tape Start relay, and action is momentary with DIP Switch 3 in the **down** position, and latching when this DIP Switch in the **up** position. See Section 4.7 for a functional description of the RECORD feature.

3.14 The XLR Audio Connectors

All of the XLR Audio Connectors used on the SPH-5/5E Telephone Hybrid follow this pin-out arrangement:

Pin 1 = GROUND
Pin 2 = Audio -
Pin 3 = Audio +

- CALLER:** This is a 600 ohm actively balanced output adjustable via the front-panel CALLER LEVEL trim-pot. Nominal output level is +4 dBm, with a clipping threshold of +21 dBm. Audio at this connector contains Caller (receive) audio only.
- RECORD/MIX:** This is a 600 ohm actively balanced output. Audio available at this connector is the sum of the selected audio input (MAIN or CUE) and the Caller audio (unity gain). This output does not contain AUXILIARY Send audio (unbalanced input from Pin 9 of the REMOTE connector).
- CUE INPUT:** This is a +4 dBm, balanced, bridging, input to the SPH-5/5E Telephone Hybrid. Input level is adjustable via the second trim pot from the left inside the front access panel. When the Cue feature is enabled, audio fed to this input will be sent to the caller, and summed with caller at the RECORD/MIX OUTPUT.
- Additionally, the CUE INPUT may be programmed via front panel DIP Switch 1 to function as an auxiliary summing input. This will combine audio from the CUE INPUT with audio from the MAIN SEND INPUT when the Cue/Hold function is not activated. Activation of the Cue/Hold function deselects the MAIN INPUT. See Section 4.7 for a description of the Cue/Hold feature.

MAIN INPUT: This is a +4 dBm, balanced, bridging input to the SPH-5/5E Telephone Hybrid. Input level is adjustable via the first trim pot on the left, inside the front access panel. When the Cue feature is not enabled, audio fed to this input will be sent to the caller, and summed with caller at RECORD/MIX output. See Section 4.7 for a description of the Cue feature.

3.15 The LINE and SET Telephone Connectors

LINE: This modular RJ-11C connector allows direct connection to the telephone line or an associated call director.

Pin designations are, right to left (as viewed from the rear of the SPH-5/5E Telephone Hybrid):

- 1 - To pin 6 of SET RJ-11C
- 2 - A-Lead Closure
- 3 - Tip
- 4 - Ring
- 5 - A-Lead Closure
- 6 - To pin 1 of SET RJ-11C

SET: This modular RJ-11C connector provides connection for a single line telephone instrument.

When the SPH-5/5E Telephone Hybrid is in the OFF mode, the telephone line (connected to the LINE RJ-11C connector) is routed to this jack. When the hybrid is in the ON mode, this jack is disabled.

Pin designations are, right to left (as viewed from the rear of the SPH-5/5E Telephone Hybrid):

- 1 - To pin 6 of LINE RJ-11C
- 2 - A-Lead Closure
- 3 - Ring
- 4 - Tip
- 5 - A-Lead Closure
- 6 - To pin 1 of LINE RJ-11C

SECTION FOUR -- OPERATION

4.1 Overview

After the SPH-5/5E Telephone Hybrid has been installed, the controls behind the removable front panel must be adjusted.

These controls consist of:

- a) Five audio control trim-pots
- b) Two null adjustments
- c) Eight DIP (option) Switches

These controls are illustrated in **Figure 15**.

The functions of these controls are summarized on the reference label attached to the reverse side of the removable front panel.

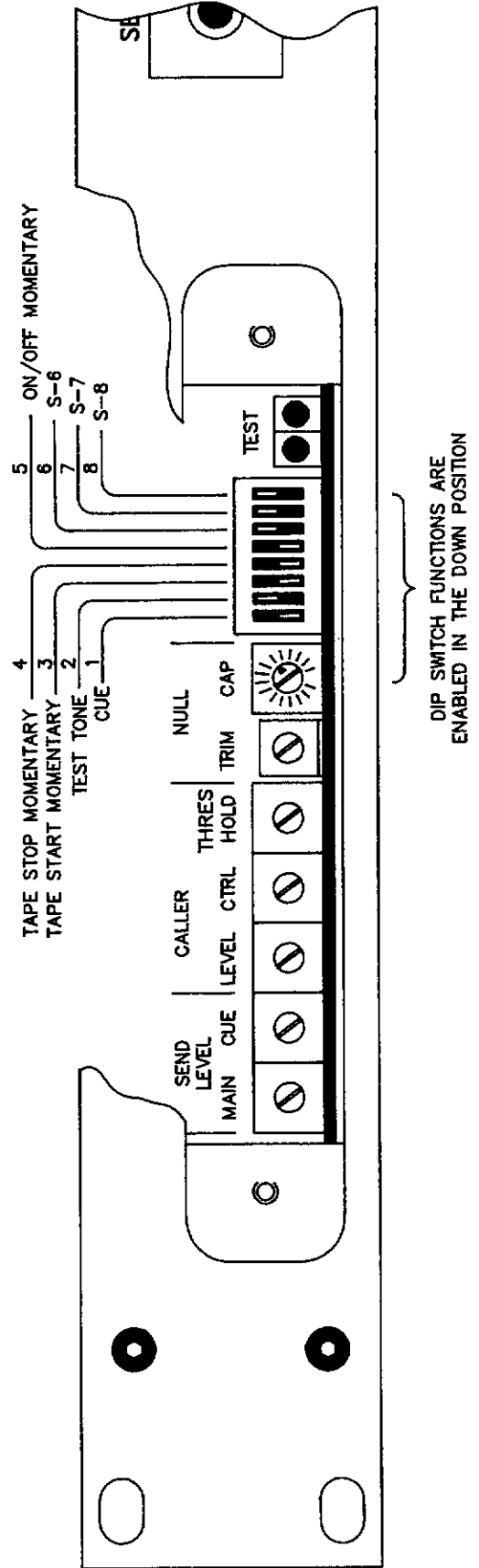

FRONT ACCESS PANEL DETAILS

Figure 15

4.2 Hybrid Null Setup Procedure

The SPH-5/5E Telephone Hybrid relies on proven analog hybrid techniques to provide its exceptional performance.

To ensure the maximum separation of Send and Caller (receive) audio, please perform the following procedure. Adjustment of the hybrid null is typically a one-time setup operation.

Refer to **Figure 15** for assistance in locating the hybrid null adjustment trim pot, the null cap select switch, and the null test points.

To setup the hybrid null for this unit, please follow these steps:

- a) Press the front panel OFF button. Remove or disconnect any Send audio feeds.
- b) Use a telephone instrument connected to the SET jack of the SPH-5/5E to dial an outside telephone line. This will provide a connection through the telephone company's central office.

The line must be a quiet line to successfully complete this procedure. This quiet line can be obtained by simply asking the party you have called to cover the mouthpiece of their telephone.

- c) Connect an AC Voltmeter to the test jacks that are located toward the right inside the front panel access door.
- d) Press the SPH-5/5E Telephone Hybrid's ON button.

NOTE: If a monitor speaker is being used, turn down the level before proceeding.

- e) Place DIP Switch 2 in the **down** position. This enables a 600 Hz null test tone.
- f) Adjust the NULL TRIM CONTROL for minimum voltage across the test jacks.

- g) Adjust the NULL CAP CONTROL for minimum voltage across the test jacks.
- h) Repeat steps f) and g) as needed to obtain the minimum possible voltage across the test jacks.
- i) Place DIP Switch 2 in the **up** position. This will disable the 600 Hz test tone.
- j) Press the SPH-5/5E Telephone Hybrid's OFF button. Restore the Send audio feeds if they were previously removed.

NOTE: This procedure is required on initial installation. If any changes are made in the telephone system, or if hybrid performance becomes degraded, the entire procedure should be repeated.

4.3 Adjusting the MAIN Send and CUE Send Input Levels

To adjust the MAIN SEND level, follow the procedure outlined below:

- a) Press the front panel OFF button.
- b) Use a telephone instrument connected to the SET jack of the SPH-5/5E to dial an outside telephone line. The line must be a quiet line. This quiet line can be obtained by simply asking the party you have called to cover the mouthpiece of their telephone.
- c) Press the ON button of the SPH-5/5E Telephone Hybrid.
- d) Make certain that the CUE (HOLD) button on the front panel is inactive (lamp is off).
- e) Apply program audio at a normal operating level to the MAIN INPUT XLR connector on the rear panel of the SPH-5/5E Telephone Hybrid.
- f) Locate the MAIN SEND LEVEL trimmer potentiometer. It is the left-most trim-pot seen when looking at the front panel. See **Figure 15**.
- g) Adjust the MAIN SEND LEVEL trim-pot so that the front panel SEND LED glows green most of the time and flashes red occasionally on peaks. Red indicates a level of 6 dB before input clipping.
- h) Press the front panel OFF button.
- i) This completes adjustment of the MAIN SEND LEVEL.

To adjust the CUE SEND level, follow the procedure outlined below:

- a) Press the front panel OFF button.
- b) Use a telephone instrument connected to the SET jack of the SPH-5/5E to dial an outside telephone line. The line must be a quiet line. This quiet line can be obtained by simply asking the party you have called to cover the mouthpiece of their telephone.
- c) Press the ON button of the SPH-5/5E Telephone Hybrid.
- d) Press the CUE (HOLD) button on the SPH-5/5E Telephone Hybrid. Make certain that the CUE (HOLD) feature is enabled (front panel CUE (HOLD) lamp is on).
- e) Apply program audio at a normal operating level to the CUE INPUT XLR connector on the rear panel of the SPH-5/5E Telephone Hybrid.
- f) Locate the CUE SEND LEVEL trimmer potentiometer. It is the second trim-pot from the left as viewed from the front panel. See **Figure 15**.
- g) Adjust the CUE SEND LEVEL trim-pot so that the front panel SEND LED glows green most of the time and flashes red occasionally on peaks. Red indicates a level of 6 dB before input clipping.
- h) Press the front panel OFF button.
- i) This completes the CUE SEND LEVEL setup.

Following the procedures just described will allow you to quickly set up the SPH-5/5E Telephone Hybrid's MAIN SEND and CUE SEND audio levels. It may be desirable to vary the settings from this point, depending on your own evaluation.

Generally speaking, you will want to avoid sending too much audio level down the telephone line. By sending a minimum audio level, the hybrid leakage into the Caller (receive) output is reduced, improving the effective performance of the hybrid.

Sending a minimum audio level has a beneficial side-effect by causing the caller to speak louder, thereby improving the signal to noise ratio on the telephone line.

4.4 Caller Level, Caller Control, and Caller Threshold

Locate the CALLER LEVEL trimmer potentiometer. It is the third trim-pot from the left as viewed from the front of the SPH-5/5E Telephone Hybrid.

Make certain that the SPH-5/5E is OFF, then initiate a telephone call using a telephone connected to the SET jack on the SPH-5/5E Telephone Hybrid.

Press the SPH-5/5E Telephone Hybrid's ON button.

While the party on the other end of the call is speaking, adjust the CALLER LEVEL trim-pot to provide the proper output level for your audio equipment.

Locate the CALLER CONTROL trimmer potentiometer. It is the fourth trim-pot from the left, as viewed from the front of the SPH-5/5E Telephone Hybrid.

The Caller CONTROL feature of the SPH-5/5E automatically reduces (dims) the level of the Caller audio when Send audio is present (when the Talent is talking).

The purpose of this control is to allow the Talent to dominate the conversation while speaking normally.

The amount of this Caller level reduction (dimming) is determined by the Caller Control trim-pot.

When the CALLER CONTROL trim-pot is fully counterclockwise, there is no Caller Control action. This is equal to 0 dB of Caller level reduction or dimming.

With the CALLER CONTROL trim-pot fully clockwise, approximately 40 dB of Caller level reduction (dimming) will occur whenever the Talent is speaking (Send audio is present). This much Caller Control causes the unit to act much like a speakerphone and is not recommended for most applications.

The CALLER CONTROL trimmer may be set for any amount of caller Caller level reduction (dimming) desired.

For most **broadcast applications**, we have found that 8 dB of Caller level reduction (dimming) allows the Talent to always be on top of a telephone conversation. The 8 dB setting allows the caller to still be heard clearly in a double-talk situation.

For most **audio conferencing applications**, we have found that 0 dB of Caller reduction provides the most natural interaction between conferencing parties, because this allows full-duplex operation. (A speakerphone can only provide half-duplex operation.) 0 dB of Caller reduction is achieved by turning the CALLER CONTROL fully counterclockwise.

The CALLER CONTROL THRESHOLD adjustment allows you to set the minimum amount of Send audio level required before Caller Control is activated. With this trimmer set towards the counter-clockwise range, a lower amount of Send audio will activate the Caller Control and initiate level reduction (dimming). As this control is adjusted clockwise, it will take increased Send level to activate the Caller Control.

It is recommended that this control be set to its mid-range initially. If you find that the Caller audio is being dimmed (reduced) too often (or too easily), then you will need to increase the threshold level by rotating the CALLER CONTROL THRESHOLD control in a clockwise direction.

If you find the Caller audio is rarely dimmed (reduced), or only dims when send levels are unusually high, you will need to lower the CALLER CONTROL THRESHOLD by turning the control counter-clockwise.

4.5 Setting the DIP Switches

There are eight switches contained in a single DIP package located behind the removeable front panel of the SPH-5/5E Telephone Hybrid. These switches are numbered 1 through 8, left to right, as viewed from the front of the unit. Refer to **Figure 15**.

The functions of the DIP Switches are as follows:

<u>DIP SWITCH</u>	<u>FUNCTION</u>
1	Cue
2	Test Tone
3	Tape Start Momentary
4	Tape Stop Momentary
5	On/Off Momentary
6	S-6
7	S-7
8	S-8

In all cases, if the DIP Switch is in the **down** position, the function is **enabled**.

A summary of the DIP Switch functions is provided on the label attached to the back of the removeable front panel cover of the SPH-5/5E Telephone Hybrid.

DIP Switch 1: Cue

In most **broadcast and audio conferencing applications**, this switch is used in the **down** position.

With this DIP Switch in the **down** position, the following applies:

- a) When the front panel CUE (HOLD) button is activated (lamp is on), the CUE INPUT is selected as the Send audio source for routing to the caller.

In a **broadcast application**, the CUE INPUT might be connected to the output of the console microphone preamplifier to allow the Talent the ability to speak with a guest "off air".

- b) If the SPH-5/5E is in the OFF mode, and the front panel REC button is activated (lamp is on steadily), the Send audio source is automatically switched to the CUE INPUT and the CUE function is activated (cue lamp on).

If the unit is then switched to the ON mode, the SPH-5/5E will issue a tape start/record enable command via the Tape Start relay, the front panel RECORD lamp will begin to flash, and the Send audio source (audio sent to the caller) will be the CUE INPUT.

When DIP Switch 1 is used in the **up** position, the following applies:

- a) The rear-panel CUE SEND input becomes a balanced AUXILIARY SEND input.
- b) This input appears at the RECORD/MIX output.

NOTE: This input cannot be used in lieu of the unbalanced AUXILIARY SEND input when conferencing multiple SPH-5/5E hybrids as described in Section 6.2 of this manual.

- c) When the CUE button is inactive (lamp is off), audio fed to the CUE SEND input is actively summed with the MAIN SEND audio input.
- d) Audio fed to the CUE input is Send audio regardless of the status of the CUE/HOLD button. When the CUE button is active (lamp is on), the CUE Send audio is selected, but MAIN Send audio is deselected.

NOTE: Using the CUE SEND input as a balanced AUXILIARY SEND input by placing DIP Switch 1 in the **up** position has no effect on the unbalanced AUXILIARY SEND input (Pin 9 and Pin 22 on the DB-25 REMOTE connector).

DIP Switch 2: Test Tone

With this DIP Switch in the **down** position, the 600 Hz test tone generator is enabled. This provides you with a signal source for use in checking audio and in setting up the hybrid null. See Section 4.2 of this manual.

This DIP Switch is normally in the **up** position so that the test tone is disabled.

DIP Switch 3: Tape Start Momentary

This DIP Switch determines the action of the Tape Start relay which has contacts appearing at Pin 1, Pin 2, and Pin 6 of the TAPE connector on the rear of the SPH-5/5E Telephone Hybrid.

When this DIP Switch is in the **down** position, the Tape Start relay uses momentary action. When this switch is in the **up** position, the Tape Start relay operates as a latching relay.

This switch is normally used in the **down** position, since the majority of tape recorders used in professional applications require a momentary remote start dry contact closure.

If your application requires a latching remote start closure, place DIP Switch 3 in the **up** position. This may be useful for cassette decks with a remote pause function. A cassette deck could be utilized as a skimmer in this way.

Refer to Section 3.13 for more information on the Tape Start relay.

NOTE: When using latching TAPE START switching, no remote TAPE STOP switch is necessary. However, normally open and normally closed TAPE STOP contacts are provided for any auxiliary functions you may wish to add.

DIP Switch 4: Tape Stop Momentary

This DIP Switch determines the action of the Tape Stop relay which has contacts appearing at Pin 3, Pin 4, and Pin 8 of the TAPE connector on the rear of the SPH-5/5E Telephone Hybrid.

When this DIP Switch is in the **down** position, the Tape Stop relay uses momentary action. When this DIP Switch is in the **up** position, the Tape Start relay operates as a latching relay.

Although a latching Tape Stop is normally not needed, both N.O. and N.C. contacts are available for use. The normal position of this DIP Switch is down.

DIP Switch 5: On/Off Momentary

When this DIP Switch is in the **down** position, the SPH-5/5E Telephone Hybrid's On/Off functions can be controlled by the two momentary front panel ON and OFF buttons, or two remote momentary switches connected to the DB-25 REMOTE connector on the rear panel of the unit. down is the normal position for this DIP Switch since it enables the front panel ON and OFF buttons.

If this DIP Switch is in the **up** position, On/Off switching can only be controlled by a single remote latching On/Off switch. The front panel ON and OFF buttons do not function normally when this DIP Switch is **up**.

Refer to Section 3.12 for the REMOTE connector pin-out information regarding the remote ON and OFF control functions.

If the user's equipment provides a latching closure output which will be used to control the SPH-5/5E Telephone Hybrid, front panel DIP Switch 5 should be placed in the **up** position.

With DIP Switch 5 in the **up** position, a latching closure across the REMOTE connector's ON pins (Pin 1 and Pin 5) will place the SPH-5/5E in the on-line state while briefly muting Caller audio to eliminate connection pops and clicks. When the closure is re-opened, the hybrid will mute and return to the off-line state.

NOTE: When using the latching ON/OFF switching, no remote OFF switch is to be used.

Figure 16 shows two examples of connection for remote ON/OFF control.

DIP Switch 6, DIP Switch 7, DIP Switch 8

These DIP Switches are reserved for future functions and upgrades of the Gentner SPH-5/5E Telephone Hybrid. To ensure that you are informed about the latest improvements, be sure to return your warranty registration card. See Section 2.3 of this manual.

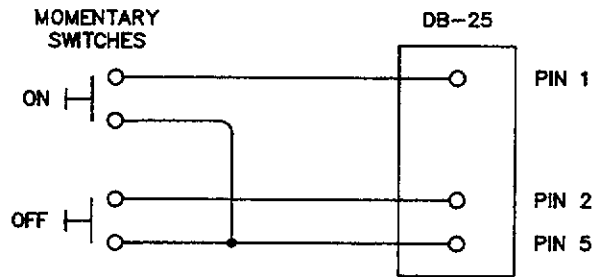

OR

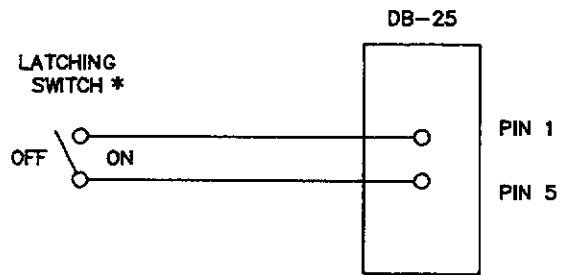

* FRONT PANEL DIP SWITCH
NO. 5 MUST BE UP

REMOTE ON/OFF CONTROL

Figure 16

4.6 Selection of Send Audio Band-Width

The SPH-5/5E offers you a choice of two Send audio filters. Selection is user-programmable via internal jumpers JP1 and JP2. As shipped, the jumper closure is located at JP2, and the full telephone Band-Width from 270 Hz to 3.3 kHz is passed. This is the normal configuration.

You may wish to select the alternate Send audio filter. This reduces the Send high-frequency response with roll-off at 2.5 kHz, but increases hybrid null performance by 2 to 3 dB as measured with pink noise.

The Send audio filter selection has no effect on the Caller audio or the RECORD/MIX audio frequency response.

NOTE: The following procedure is NOT recommended for the model SPH-5E (Extended Frequency Transceiver/Hybrid).

Selection of the alternate narrow-band Send audio filter is accomplished by re-positioning the internal jumper to the JP1 position. **Figure 17** shows the location of jumpers JP1 and JP2.

CAUTION: DISCONNECT THE SPH-5 FROM AC POWER BEFORE PROCEEDING.

STEP 1

Remove all connections from the SPH-5/5E, and remove the unit from service. Remove the cover from the SPH-5/5E by loosening the four cover screws. (Note that the screws need only be loosened, not removed.)

STEP 2

Place the SPH-5/5E in front of you, top side up, with the front panel of the unit facing you. The removable front access panel should now be on the left-hand side, and the OFF and ON buttons should be on the right-hand side of the unit.

Jumper positions JP1 and JP2 will be found toward the center of the printed circuit board. **Figure 17** shows the location of jumpers JP1 and JP2.

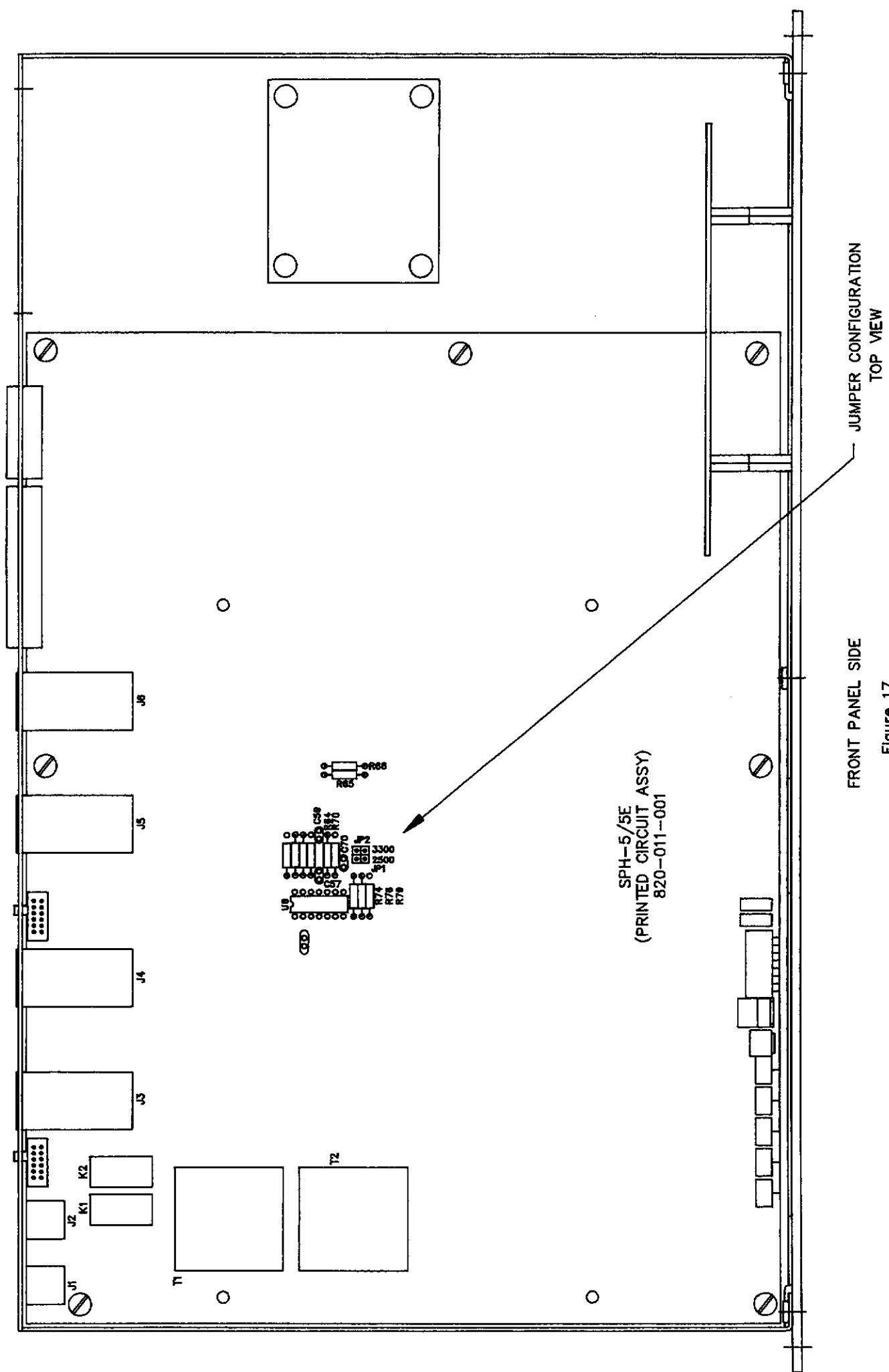

FRONT PANEL SIDE

Figure 17

JUMPER CONFIGURATION
TOP VIEW

SPH-5/5E
(PRINTED CIRCUIT ASSY)
820-011-001

STEP 3

Remove the jumper from the JP2 position and place it in the JP1 position. This changes the Send audio high frequency cut off from 3.3 kHz to 2.5 kHz.

STEP 4

Replace the top cover of the SPH-5/5E and secure the top cover by tightening the four screws previously loosened in Step 1.

Re-connect all inputs and outputs for the SPH-5/5E. Connect electrical power and restore the unit to service.

4.7 Front Panel Controls and Indicators

In addition to the trim-pots and DIP Switches located behind the removable front access panel, the front panel of the SPH-5/5E Telephone Hybrid contains the following controls and indicators from right to left:

ON button, with ON indicator

OFF button, with OFF indicator

CUE (HOLD) button, with CUE (HOLD) indicator

EXT button, with EXTEND indicator*

REC button, with RECORD indicator

CALLER LED

SEND LED

* On SPH-5E only

ON: When the ON button is pressed, the SPH-5/5E closes its telephone line relay, connecting the hybrid circuitry to the telephone line. At this time, the ON button indicator will glow indicating an on-line status.

The hybrid mutes Caller audio, waits for the telephone loop current to become stable, and then removes the mute from the Caller amplifier, allowing telephone line audio to appear at the appropriate output connections on the rear panel.

If the RECORD mode was selected prior to activating the ON button, pressing the ON button will simultaneously start the tape recorder and enable the tape recorder's record function via the Tape Start relay.

OFF: When the OFF button is pressed, the SPH-5/5E disconnects from the telephone line and illuminates the OFF button indicator. If the RECORD function was enabled, the tape recorder will be stopped via the Tape Stop relay.

CUE (HOLD): For **broadcast applications** this switch is labeled CUE, and pressing the CUE (HOLD) button causes the SPH-5/5E to toggle between the MAIN SEND and CUE SEND audio inputs.

For **audio conferencing applications**, this switch is labeled HOLD. Pressing the HOLD button mutes the incoming caller's audio and either mutes or switches Send audio (audio going to the caller) from the MAIN SEND input to the CUE SEND input. See Section 5.2 for additional information.

NOTE: If DIP Switch 1 is in the **up** position, audio sent to the MAIN SEND and CUE SEND inputs may be summed. See Section 4.5.

When the CUE (HOLD) button is active (lamp is on), the CUE SEND input is selected as the source for Send audio. For **broadcast applications**, this mode allows you to easily make off-the-air recordings for playback at a later time. For **audio conferencing applications**, this mode allows you to hold a private conversation while the other party is listening to music-on-hold.

When the CUE (HOLD) button is not active (lamp is off), the Send audio will be routed from the MAIN Send line level input to the caller. In **broadcast applications**, this mode would be selected for on-the-air live broadcast of telephone conversations. In **audio conferencing applications**, this is the normal conferencing mode.

When using the SPH-5/5E in **broadcast applications**, console module switching logic can be used to control this function. The console module logic will always update the SPH-5/5E Send source status ensuring that the proper audio will always be sent to the caller.

EXT: When the EXT button is pressed, Send audio is shifted upward 250 Hz and then it is sent down the telephone line. Caller audio is shifted downward 250 Hz. This utilizes the encode/decode capabilities of Gentner's Extended Frequency Transceiver (EFT) to provide full-duplex, high quality audio.

NOTE: Single-line frequency extension requires the use of compatible units at both ends. The Gentner EFT-100, EFT-900 and EFT-1000 products may be used. Contact Gentner for further information regarding Frequency Extension.

REC: In **broadcast applications**, if the SPH-5/5E is off and the REC button is pressed, the SPH-5/5E will automatically activate the CUE mode. This function would commonly be used for recording conversations for playback at a later time.

In **audio conferencing applications**, if the SPH-5/5E is OFF and the REC button is pressed, the SPH-5/5E will automatically select the HOLD mode. To deselect the HOLD mode, press the HOLD button.

Please see the discussion of the CUE (HOLD) button in this section.

If the SPH-5/5E is in the OFF mode, and the RECORD mode is activated (lamp is on), indicating ready to record, pressing the ON button will:

- a) Connect the caller to the selected Send audio source.
- b) Start the tape recorder via the Tape Start relay.
- c) Enable the Record function on the tape recorder via the Tape Start relay.

When the RECORD and ON functions are both enabled, the REC light flashes to indicate that tape start and record enable commands have been issued.

With the SPH-5/5E in the RECORD mode, pressing the ON button will start the tape recorder and enable the record function.

If the SPH-5/5E is already in the ON mode, pressing the REC button will start the tape recorder and enable the record function.

While operating the SPH-5/5E in the RECORD mode, pressing either the OFF button or the REC button will stop the tape recorder via the Tape Stop relay.

SEND LED: When the SPH-5/5E is on-line, the SEND LED will glow green when it senses that Send audio is present. The SEND LED will flash red to indicate that the Send level is 6 dB before clipping.

CALLER LED: This LED will glow green when the SPH-5/5E senses Caller (receive) audio from the telephone line. The CALLER LED will flash red to indicate a level of 6 dB before clipping.

4.8 Remote Control of SPH-5/5E Telephone Hybrid Functions

Many functions of the SPH-5/5E can be controlled and monitored remotely via the rear panel DB-25 and DB-9 connectors as indicated below:

REMOTE FUNCTIONS

Remote On
Remote Off
Remote Record
Remote Cue (Hold)
Remote Cue (Console)
Send Mute (Privacy Switch)
Caller (Receive) Mute
Remote Extend (SPH-5E Only)
Aux Relay Dry Contacts
Remote Tape Recorder Start
Remote Tape Recorder Stop
Record Enable

REMOTE INDICATORS

ON Indicator
OFF Indicator
RECORD Indicator
CUE (HOLD) Indicator
Remote Extend (SPH-5E Only)

Sections 3.12 and 3.13 of this manual also contain installation information regarding remote control functions.

ON/OFF Switching

The ON and OFF functions of the SPH-5/5E may be remoted using separate momentary ON and OFF Switches or by a single toggle switch.

If momentary switches are used, front panel DIP Switch 5 must be in the **down** position. If a toggle switch is used, front panel DIP Switch 5 must be **up**.

NOTE: If you choose to use the remote ON/OFF switching in the latching mode, the SPH-5/5E the front panel ON/OFF button will not function normally.

A momentary closure between Pin 1 and Pin 5 on the 25-pin REMOTE connector will turn ON the SPH-5/5E (if DIP Switch 5 is in the **down** position). Section 4.5 of this manual discusses DIP Switch settings.

A momentary closure between Pin 2 and Pin 5 on the REMOTE connector will turn OFF the SPH-5/5E (if DIP Switch 5 is in the **down** position). Section 4.5 discusses DIP Switch settings and **Figure 16** illustrates momentary and latching methods of remote ON/OFF control.

RECORD

The Remote RECORD function is accessed via Pin 3 and Pin 5 on the 25-pin REMOTE connector. A momentary closure between these pins toggles between the Normal and Record modes of operation. Refer to **Figure 18** for an illustration of using this function.

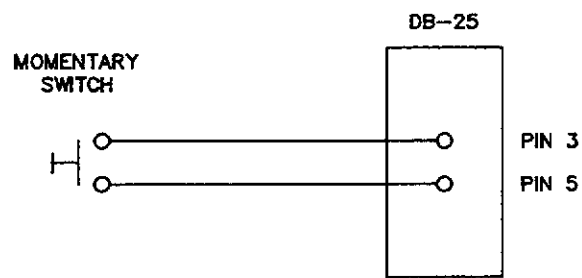

REMOTE RECORD CONTROL

Figure 18

CUE (HOLD)

Connections to remotely control the CUE (HOLD) feature are found on Pin 4 and Pin 5 of the REMOTE connector. A momentary closure between these pins toggles between CUE (HOLD) active and inactive states. See **Figure 19** for an example of using this connection.

NOTE: If console logic is to be used to remotely control the CUE feature in **broadcast applications**, Pin 8 and Pin 5 should be used to control the CUE function because they are setup to accept a latching closure from console logic.

The remote CUE (HOLD) connections (Pin 4 and Pin 5) are for momentary operation identical to the front-panel CUE (HOLD) button of the SPH-5/5E Telephone Hybrid.

Both types of control may be used simultaneously.

To enable the HOLD function, follow the procedure described in Section 5.2 of this manual.

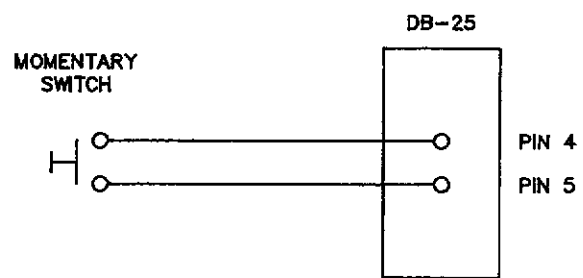

REMOTE CUE (HOLD) CONTROL

Figure 19

Send Mute (Privacy Switch)

The SPH-5/5E Telephone Hybrid's Send audio (audio going to the caller) may be remotely muted by providing a closure between Pin 5 and Pin 6 on the REMOTE connector. The muting action is latching; that is, as long as a closure exists between Pin 5 and Pin 6, Send audio will be muted.

This function does not appear on the front panel and is valuable for use as a privacy switch when used in **audio conferencing applications**. **Figure 20** shows how this function can be remotely controlled.

Caller (Receive) Mute

A continuous closure between Pin 5 and Pin 7 on the REMOTE connector will cause the SPH-5/5E Telephone Hybrid's Caller (Receive) audio to be muted. **Figure 20** indicates how this may be accomplished.

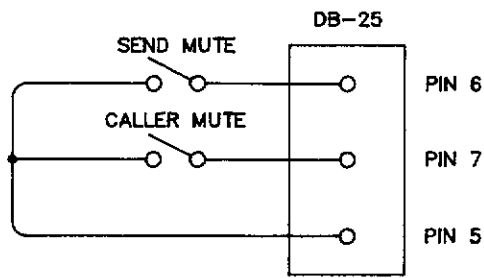

REMOTE SEND AND CALLER MUTING

Figure 20

EXTEND (SPH-5E Only)

A momentary closure between Pin 20 and Pin 5 on the REMOTE connector toggles alternately between the Normal and Frequency Extension modes of operation.

AUXILIARY RELAY CONTACTS

Refer to Figure 21. The SPH-5/5E Telephone Hybrid provides Auxiliary dry relay contacts that follow the action of the ON/OFF Switching functions. Pin 12 is normally open when the SPH-5/5E is in the OFF mode. The pin-out on the 25-pin REMOTE connector for this relay is as follows:

- 12 Aux Relay N.O.
- 13 Aux Relay N.C.
- 25 Aux Relay Common

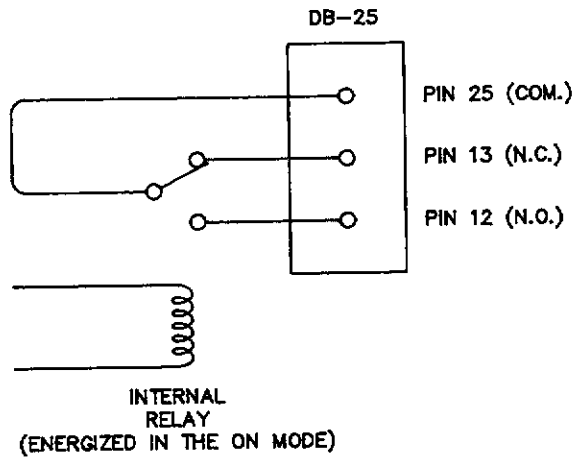

AUXILIARY RELAY PIN-OUT

Figure 21

TAPE START AND RECORD ENABLE RELAY

The SPH-5/5E Telephone Hybrid's unique remote Tape Start and Record Enable capability may be accessed via connections made to the 9-pin TAPE connector on the rear panel. See Section 3.13 of this manual for additional information.

These connections provide dry contact closures for the Tape Start relay. Action of the relay is momentary when DIP Switch 3 is in the **down** position, and latching when this DIP Switch in the **up** position. Section 4.5 discusses DIP Switch settings.

The pin-outs for the Tape Start and Record Enable functions of the TAPE connector are as follows:

- 1 -- N.O. Tape Start Relay Contact
- 2 -- N.C. Tape Start Relay Contact
- 6 -- Tape Start Common
- 7 -- N.C. Record Enable (To tape recorder)
- 5 -- N.O. Record Enable (To tape recorder)
- 9 -- Record Enable Common (To tape recorder)

See Section 4.7 for a description of the RECORD feature.

Figure 22 shows an example for use of these connections.

TAPE STOP

Connections are provided on the TAPE connector to access the Tape Stop relay.

The pin-out for the Tape Stop relay is given below:

- 3 -- N.O. Tape Stop Relay Contact
- 4 -- N.C. Tape Stop Relay Contact
- 8 -- Tape Stop Common

Action of this relay is momentary when DIP Switch 4 is in the **down** position, and latching when this DIP Switch is in the **up** position. Section 4.5 discusses DIP Switch settings. Please refer to **Figure 22** for an example of using these connections.

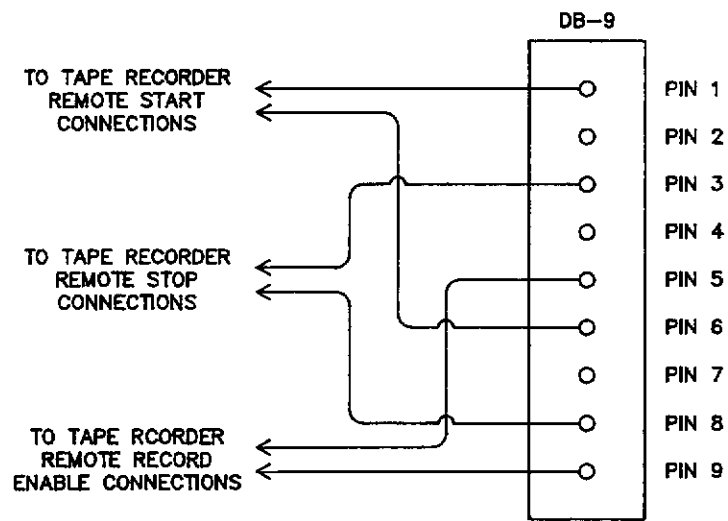

REMOTE TAPE START/STOP/RECORD CONTROL

Figure 22

4.9 Remote Indicators

LED's or incandescent lamps may be used for remote monitoring of the SPH-5/5E Telephone Hybrid's status indications.

Figure 23 shows how incandescent lamps may be used as remote ON, OFF, RECORD, CUE (HOLD), and EXTEND status indicators by connecting them respectively to Pin 14, Pin 15, Pin 16, Pin 17, and Pin 19. (EXTEND status applies to model SPH-5E only.)

An external DC power supply to provide lamp voltage is required.

CAUTION: Care must be taken to reference the external power supply to the ground provided at Pin 18 of the SPH-5/5E REMOTE connector.

Total current into each of Pin 14, Pin 15, Pin 16, Pin 17, and Pin 19 must not exceed 100 mA, and the power supply voltage must not exceed 40 VDC.

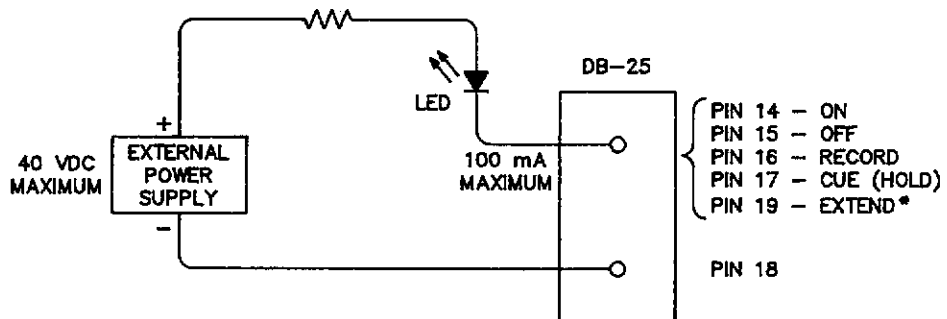
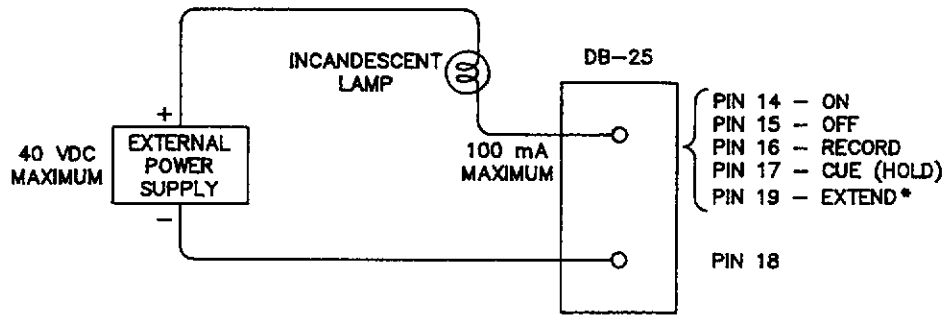

* ON MODEL SPH-5E ONLY.

REMOTE INDICATORS

Figure 23

4.10 Adding External Relays

An external relay can be driven from any one of the following remote indicator outputs:

ON, OFF, RECORD, CUE (HOLD), EXTEND (SPH-5E only)

An illustration of relay connection is shown in **Figure 24**.

An external power supply capable of providing the relay's coil voltage is required.

CAUTION: Care must be taken to reference the external power supply to ground at Pin 18 of the SPH-5/5E Telephone Hybrid's REMOTE connector. Total current into any one pin must not exceed 100 mA, and the power supply voltage must never exceed 40 VDC.

More information regarding the 25-pin REMOTE connector and the 9-pin TAPE connector is contained in Sections 3.12 and 3.13 of this manual.

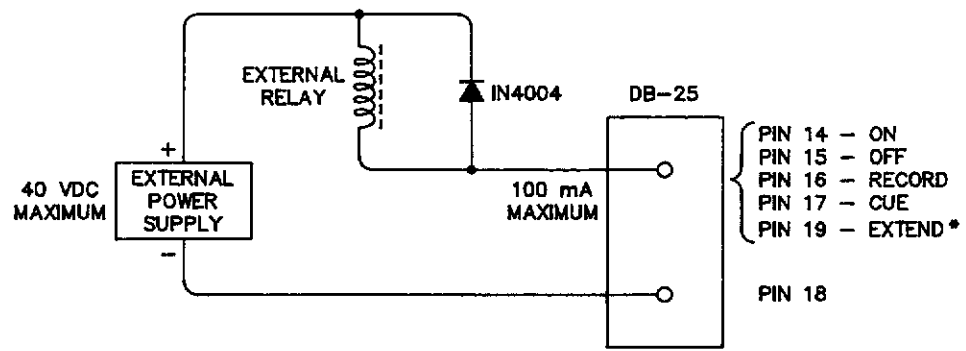

* ON MODEL SPH-5E ONLY.

ADDING EXTERNAL RELAYS

Figure 24

SECTION FIVE -- AUDIO CONFERENCING

5.1 Overview

The Gentner SPH-5/5E offers full duplex audio transmission. This means that both sides of a conversation may be heard without gating or switching, even when both sides are speaking simultaneously. This permits conversation to occur in a normal manner without the irritating restrictions imposed by speakerphones.

Please refer to **Figure 25** to locate the switches mentioned below.

The SPH-5/5E's HOLD button allows you to mute the incoming caller's audio and either mute or switch Send audio (audio going to the caller) to another source while you conduct a private conversation.

With the SPH-5/5E, you can record both sides of a telephone conference simply by pressing the REC button. A tape recorder is then automatically started by the SPH-5/5E. Pressing the REC button again, or the OFF button on the SPH-5/5E, stops the recorder.

The SPH-5/5E can be used with a wide variety of microphone mixers and sound systems. If you have any questions about interfacing the SPH-5/5E with your sound system, contact Gentner Customer Support.

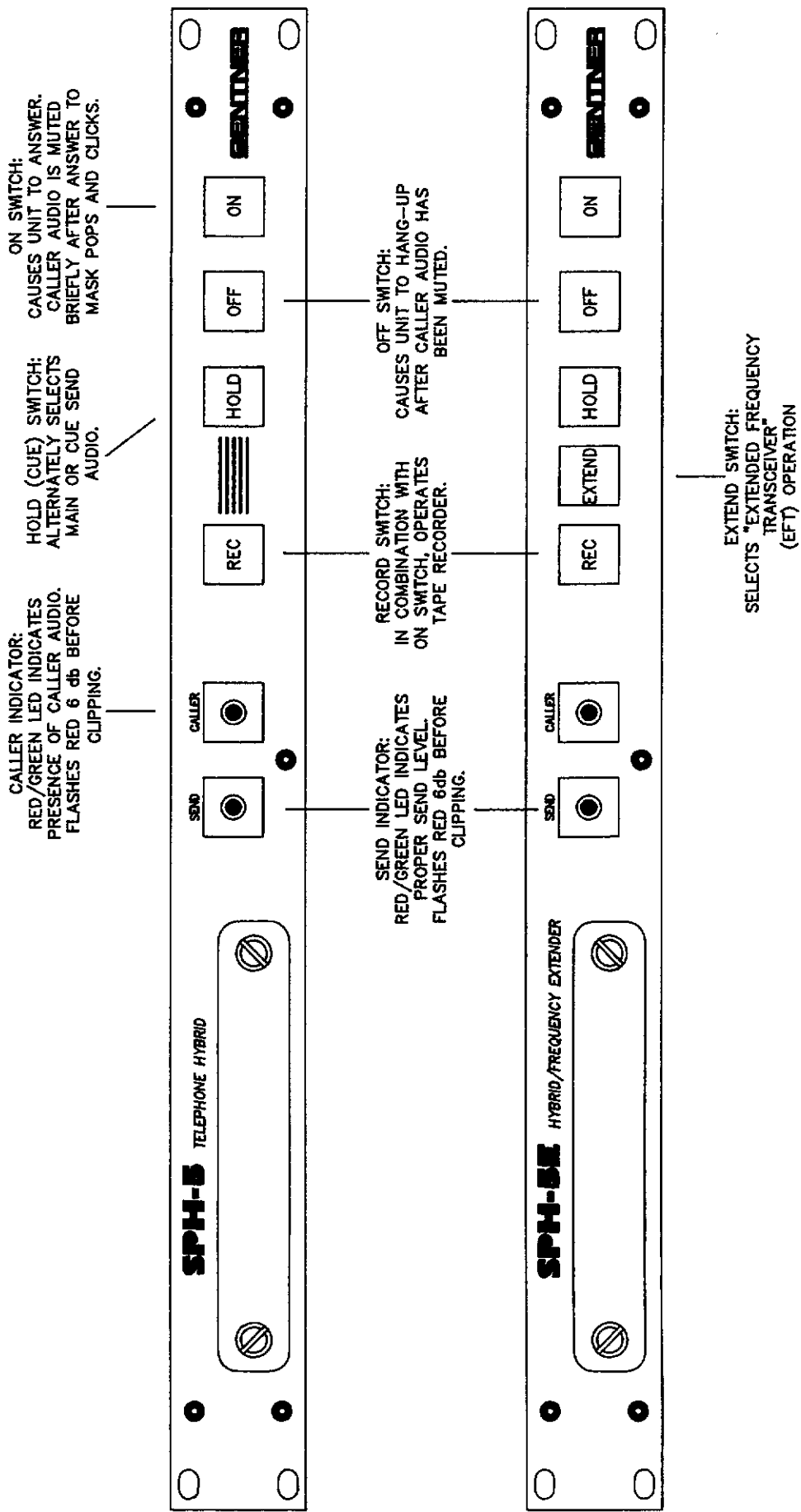

SPH-5/5E
"FRONT PANEL FUNCTIONS"

Figure 25

5.2 Audio Conferencing Installation

Audio conferencing users will have a slightly different setup of the SPH-5/5E than **broadcast** users.

See **Figure 26** for an illustration of a basic audio conferencing setup.

To install the unit in a conference room, do the following:

- a) Make sure the SPH-5/5E is configured for the proper AC power input. See **Figure 27**. Section 3.3 of this manual contains additional information regarding operating voltage selection.
- b) Remove the CUE button cap by grasping it with your fingers and pulling it straight out. Remove the clear plastic cover from the cap and replace the CUE legend with the HOLD legend supplied. Replace the clear plastic cover and re-install the switch cap.
- c) Install a jumper between Pin 7 and Pin 17 on the DB-25 Remote connector to provide Caller muting when HOLD is selected. For assistance in locating these pins, see **Figure 29**.
- d) Mount the unit in a standard 19" equipment rack or in a rack cabinet adjacent to the room's microphone mixer and amplifier system. Be sure the unit receives adequate ventilation.

e) Connect audio equipment to the SPH-5/5E as indicated:

<u>FROM</u>	<u>TO</u>
Microphone mixer output	MAIN SEND input
"Hold" audio source	CUE SEND input
CALLER output	P.A. input
RECORD/MIX output	Tape recorder

The audio connections to the SPH-5/5E are 600 ohm, +4 dBm nominal and are made via the rear-panel XLR connectors. Unbalanced audio connections are also available on the Remote connector as indicated in **Figure 29**.

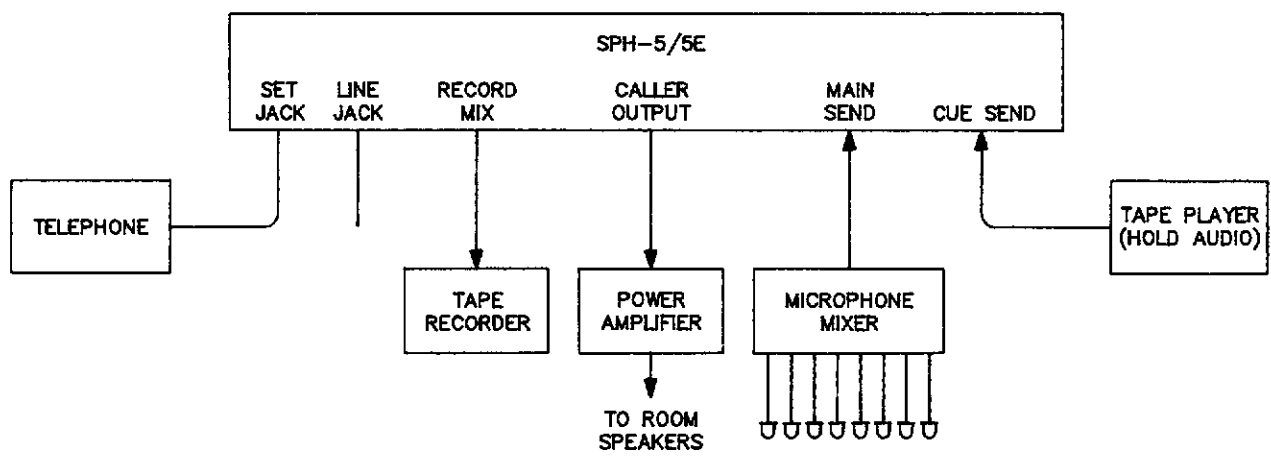

BASIC AUDIO CONFERENCING SETUP

Figure 26

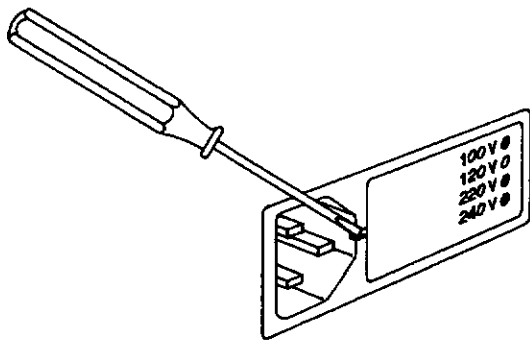

REMOVE COVER PANEL USING
SMALL SCREW DRIVER OR
SIMILAR TOOL.

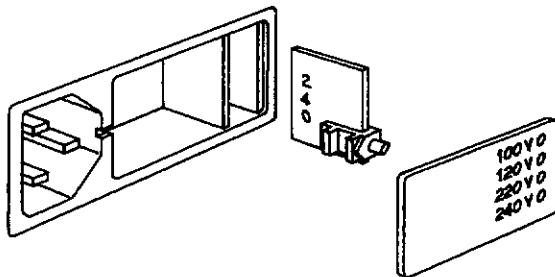
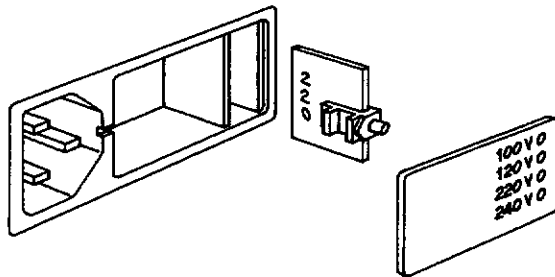
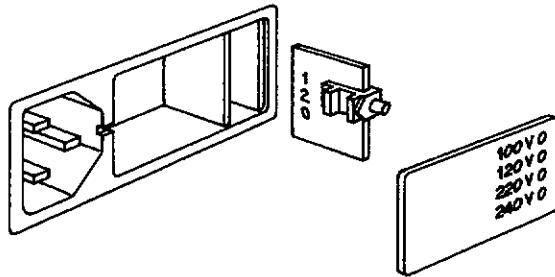
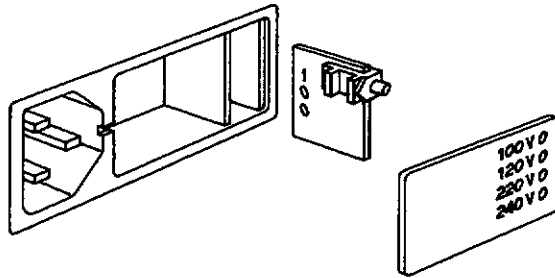

PULL VOLTAGE SELECTION CARD
FROM ITS HOUSING AND ROTATE
AS SHOWN TO PLACE PLASTIC
INDICATOR TAB IN THE REQUIRED
POSITION FOR THE DESIRED
VOLTAGE.

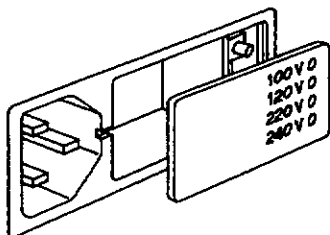

PUSH VOLTAGE SELECTION CARD
BACK INTO ITS HOUSING AND
REPLACE COVER PANEL.

SETTING UP THE AC POWER INPUT

Figure 27

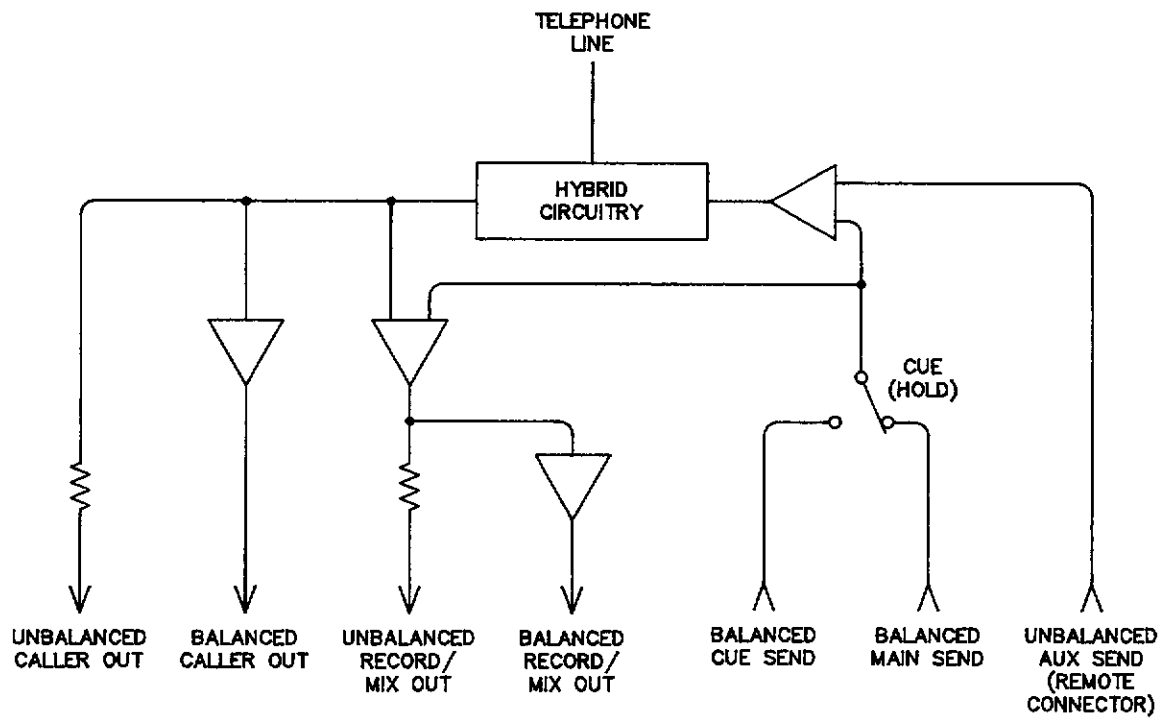

SPH-5/5E
AUDIO CONNECTIONS

Figure 28

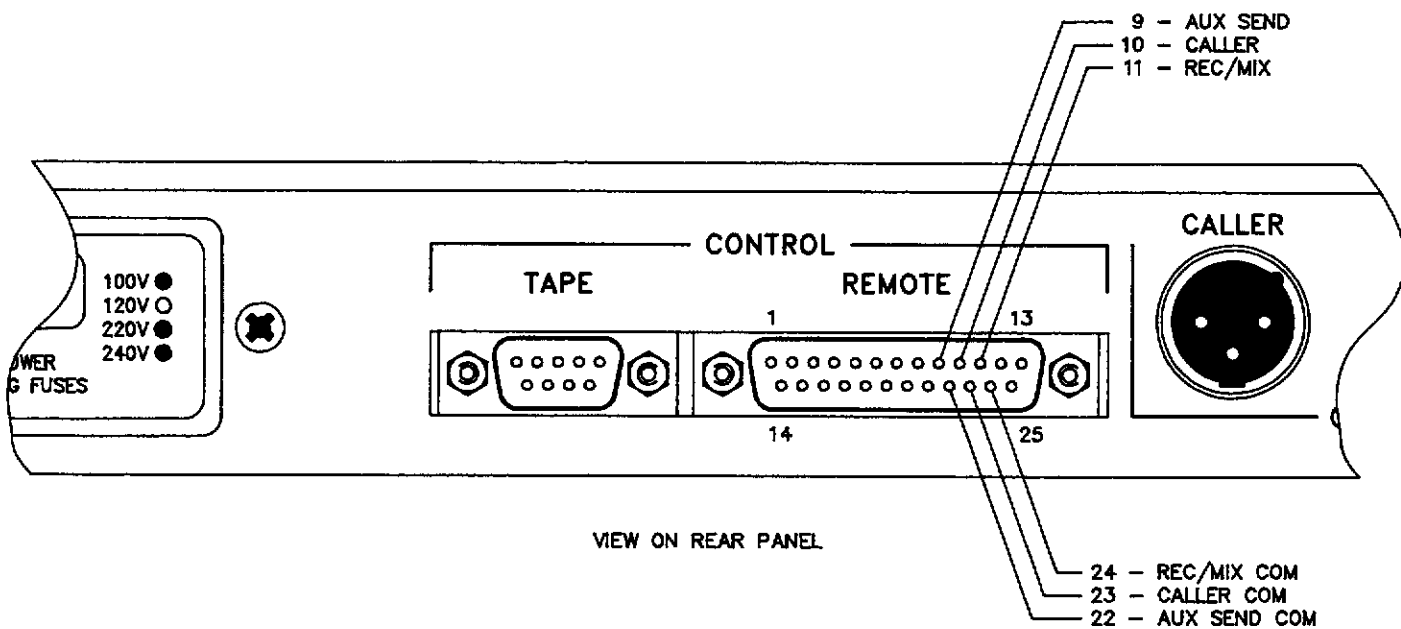

VIEW ON REAR PANEL

NOTE: AUDIO CONNECTIONS ON REMOTE CONNECTOR ARE UNBALANCED.

REMOTE CONNECTOR AUDIO PIN OUTS

Figure 29

- f) Refer to **Figure 30** and connect a telephone line cord to the modular RJ-11C connector marked "LINE" on the rear of the SPH-5/5E.
- g) Refer to **Figure 30** and connect a telephone set to the modular RJ-11C connector marked "SET" on the rear of the SPH-5/5E. This set will be used to establish conference calls, and to access the telephone line when the conference system is not in use.
- h) Connect the unit to power.
- i) Setup the hybrid null and audio levels following the procedures outlined in Sections 4.2, 4.3, and 4.4 of this manual.
- j) If you are planning to operate the SPH-5/5E from an outboard control panel, all control functions of the unit can be accessed via the REMOTE connector on the rear panel. See **Figure 31**.
- k) A remote "Privacy Switch" may be installed. Either momentary or latching contacts may be used. Connections to the REMOTE connector are made to Pin 5 and Pin 6.
- l) The HOLD button may be configured as a Privacy Switch by installing a jumper between Pin 6 and Pin 17 of the REMOTE connector. Closure between these pins causes Send audio to be muted.

POWER SUPPLY:
100-120/220-240 VAC
OPERATION.

REMOTE CONTROL:
REMOTE CONNECTOR INCLUDES
REMOTE CONTROL AND AUDIO
CONNECTIONS

RECORD/MIX OUTPUT:
CONTAINS BOTH SEND AND
CALLER AUDIO.

MAIN INPUT:
MAIN SEND LINE
LEVEL INPUT.
WHEN SELECTED, THIS
AUDIO IS SENT TO
THE CALLER.

TELCO SET:
CONNECT TELEPHONE
SET HERE.

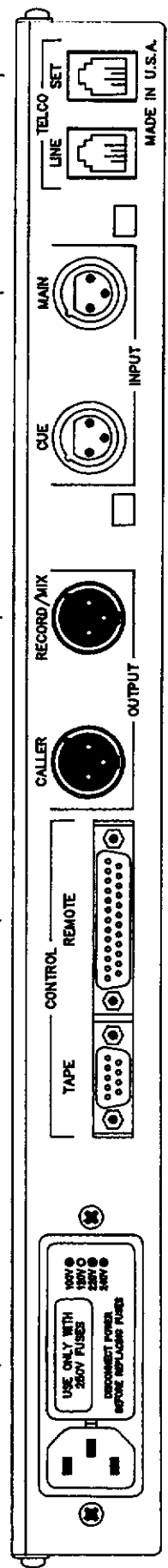

TAPE CONTROL:
TAPE CONNECTOR INCLUDES
RELAY CONTACT CONNECTIONS
TO TAPE RECORDER.

CALLER OUTPUT:
CONTAINS CALLER
AUDIO ONLY.

CUE INPUT:
CUE SEND LINE LEVEL INPUT.
WHEN SELECTED, THIS AUDIO
IS SENT TO THE CALLER.

TELCO LINE:
CONNECT TELEPHONE
LINE HERE.

SPH-5/5E
"REAR PANEL SUMMARY"

Figure 30

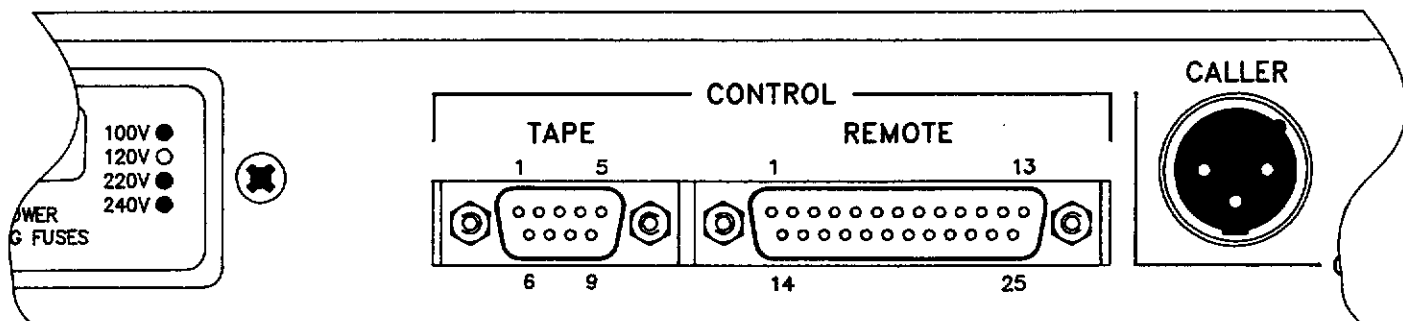

VIEW ON REAR PANEL

THE REMOTE CONNECTOR IS A 25-PIN D-TYPE CONNECTOR LOCATED ON THE REAR PANEL OF THE SPH-5/5E. SEE SECTION 3.12 FOR MORE SPECIFIC DETAILS.

- | | |
|--------------------------------|----------------------------|
| 1 - REMOTE ON | 14 - ON INDICATOR |
| 2 - REMOTE OFF | 15 - OFF INDICATOR |
| 3 - REMOTE RECORD | 16 - RECORD INDICATOR |
| 4 - REMOTE CUE (HOLD) | 17 - CUE INDICATOR |
| 5 - SWITCH COMMON | 18 - INDICATOR COMMON |
| 6 - SEND MUTE (PRIVACY SWITCH) | 19 - EXTEND INDICATOR* |
| 7 - CALLER MUTE | 20 - REMOTE EXTEND SWITCH* |
| 8 - REMOTE CUE (CONSOLE) | 21 - NOT USED |
| 9 - UNBALANCED AUX SEND | 22 - AUX SEND AUDIO COMMON |
| 10 - UNBALANCED CALLER | 23 - CALLER AUDIO COMMON |
| 11 - UNBALANCED REC/MIX | 24 - REC/MIX AUDIO COMMON |
| 12 - AUX RELAY N.O. | 25 - AUX RELAY COMMON |
| 13 - AUX RELAY N.C. | |

*ON MODEL SPH-5E ONLY.

THE TAPE CONNECTOR IS A 9-PIN D-TYPE CONNECTOR LOCATED ON THE REAR PANEL OF THE SPH-5/5E.

- | | |
|------------------------|--------------------------|
| 1 - N.O. TAPE START | 6 - TAPE START COMMON |
| 2 - N.C. TAPE START | 7 - RECORD ENABLE N.C. |
| 3 - N.O. TAPE STOP | 8 - TAPE STOP COMMON |
| 4 - N.C. TAPE STOP | 9 - RECORD ENABLE COMMON |
| 5 - N.O. RECORD ENABLE | |

SPH-5/5E
REMOTE AND TAPE CONNECTOR PIN OUTS

Figure 31

5.3 Setting the DIP Switches

There are eight switches contained in a single DIP package located behind the removable front panel of the SPH-5/5E. Refer to **Figure 32**, remove the front access panel, and configure the DIP Switches as needed.

NOTE: In all cases, if the DIP Switch is in the **down** position, the function is enabled.

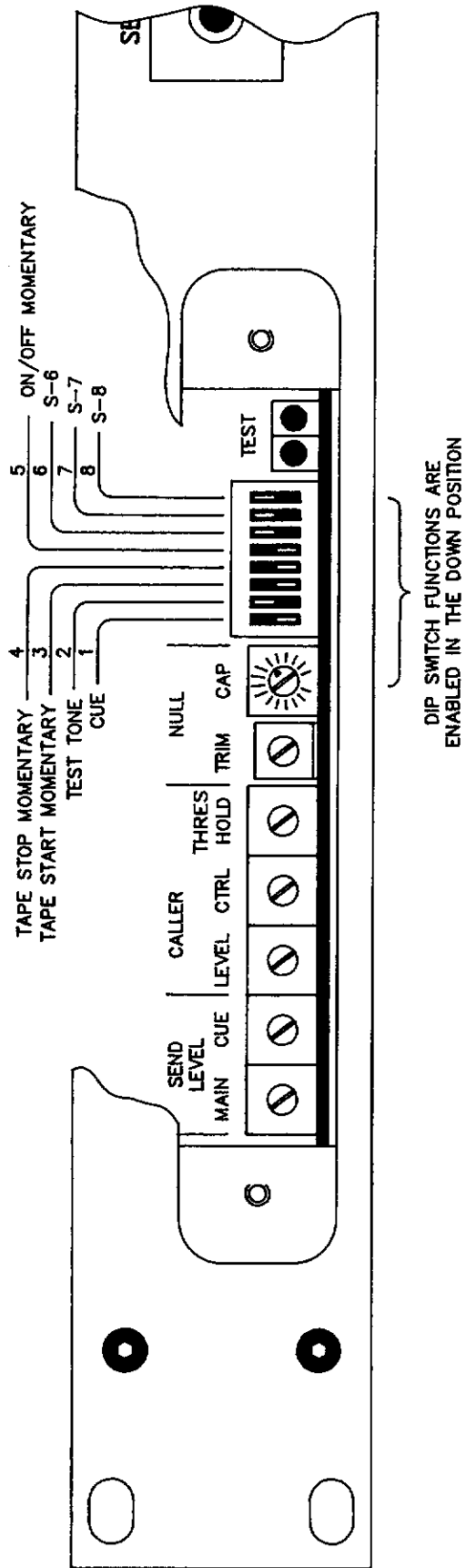

FRONT ACCESS PANEL DETAILS

Figure 32

DIP Switch 1: CUE

For most **audio conferencing** applications, this switch will be used in the **down** position. With this DIP Switch in the **down** position, the following applies:

- a) When the front panel CUE button is activated (lamp is on), the CUE INPUT is selected as the Send audio source for routing to the caller.
- b) If the SPH-5/5E is in the OFF mode, and the front panel REC button is activated (lamp is on steadily), the Send audio source is automatically switched to the CUE INPUT and the CUE function is activated (cue lamp on).

If the unit is then switched to the ON mode, the SPH-5/5E will issue a tape start/record enable command via the Tape Start relay, the front panel RECORD lamp will begin to flash, and the Send audio source (audio sent to the caller) will be the CUE INPUT.

When DIP Switch 1 is used in the **up** position, the following applies:

- a) The rear-panel CUE SEND input becomes a balanced AUXILIARY summing input. This combines audio from the CUE INPUT with audio from the MAIN SEND INPUT when the Cue/Hold function is not enabled. See Section 4.7 for a description of the CUE feature.

NOTE: Since this input appears at the RECORD/MIX output it cannot be used in place of the unbalanced AUXILIARY SEND input when conferencing multiple SPH-5/5E hybrids. See Section 6.2 of this manual for information regarding conferencing multiple hybrids.

- b) When the CUE button is inactive (lamp is off), audio fed to the CUE SEND input is actively summed with the MAIN SEND audio input.

- c) When the CUE button is active (lamp is on), the MAIN SEND audio is deselected and the CUE SEND audio remains selected.

NOTE: Using the CUE SEND input as a balanced AUXILIARY SEND input has no effect on the unbalanced AUXILIARY SEND input (Pin 9 and Pin 22 on the DB-25 REMOTE connector).

DIP Switch 2: Test Tone

With this switch in the **down** position, the 600 Hz test tone generator is enabled. This DIP Switch is normally in the **up** position so that the test tone is disabled. See Section 4.2 for further information.

DIP Switch 3: Tape Start Momentary

This DIP Switch determines the action of the Tape Start relay which has contacts appearing at Pin 1, Pin 2, and Pin 6 of the TAPE connector on the rear of the SPH-5/5E Telephone Hybrid.

When this DIP Switch is in the **down** position, the Tape Start relay uses momentary action. When this switch is in the **up** position, the Tape Start relay operates as a latching relay.

This switch is normally used in the **down** position, since the majority of tape recorders used in professional applications require a momentary remote start dry contact closure.

Refer to Section 3.13 for more information on the Tape Start relay.

NOTE: When using latching TAPE START switching, no remote TAPE STOP switch is necessary. However, normally open and normally closed TAPE STOP contacts are provided for any auxiliary functions you may wish to add.

DIP Switch 4: Tape Stop Momentary

This DIP Switch determines the action of the Tape Stop relay which has contacts appearing at Pin 3, Pin 4, and Pin 8 of the TAPE connector on the rear of the SPH-5/5E Telephone Hybrid.

When this DIP Switch is in the **down** position, the Tape Stop relay uses momentary action. When this switch is in the **up** position, the Tape Start relay operates as a latching relay.

Although a latching Tape Stop is normally not needed, both N.O. and N.C. contacts are available for use. The normal position of this DIP Switch is down.

DIP Switch 5: On/Off Momentary

When this DIP Switch is in the **down** position, the SPH-5/5E Telephone Hybrid's On/Off functions can be controlled by the two momentary front panel ON and OFF switches, or two remote momentary switches connected to the DB-25 REMOTE connector on the rear panel of the unit. **Down** is the normal position for this DIP Switch since it enables the front panel ON and OFF Switches.

If this switch is in the **up** position, On/Off switching can only be controlled by a single remote latching on/off switch. The front panel ON and OFF buttons do not function normally when this DIP Switch is **up**.

Refer to Section 3.12 for the REMOTE connector pin-out information regarding the remote ON and OFF control functions.

If the user's equipment provides a latching closure output which will be used to control the SPH-5/5E Telephone Hybrid, front panel DIP Switch 5 should be placed in the **up** position.

NOTE: When using the latching ON/OFF switching, no remote OFF Switch is to be used.

DIP Switch 6, DIP Switch 7, DIP Switch 8

These DIP Switches are reserved for future functions and upgrades of the Gentner SPH-5/5E Telephone Hybrid.

For other information on the functions of the DIP Switches, refer to Section 4.5 of this manual.

5.4 Conference Room Setup

Figure 33 illustrates a typical conference room setup.

The major advantage of the setup shown is that the participants can listen while talking. The speaker is not turned off and on as it would be with a speakerphone.

This permits a more natural, two-way flow of conversation between conference rooms, without annoying cut-offs.

In this setup, four directional microphones are mixed together.

The output of the mixer is routed to the MAIN SEND input of the SPH-5/5E.

The CALLER output of the SPH-5/5E is sent to the input of a power amplifier.

The power amp drives a loudspeaker.

Care must be taken to ensure that speaker placement does not result in acoustic pick-up by microphones.

Time spent considering the choice of microphones, their placement, and pickup patterns is well spent.

Relative position of the microphones to the loudspeakers must be carefully considered to minimize the possibility of feedback.

If room resonance is a problem, corrective equalization of the P.A. system may be necessary. Your sound contractor will be able to assist you if equalization is needed.

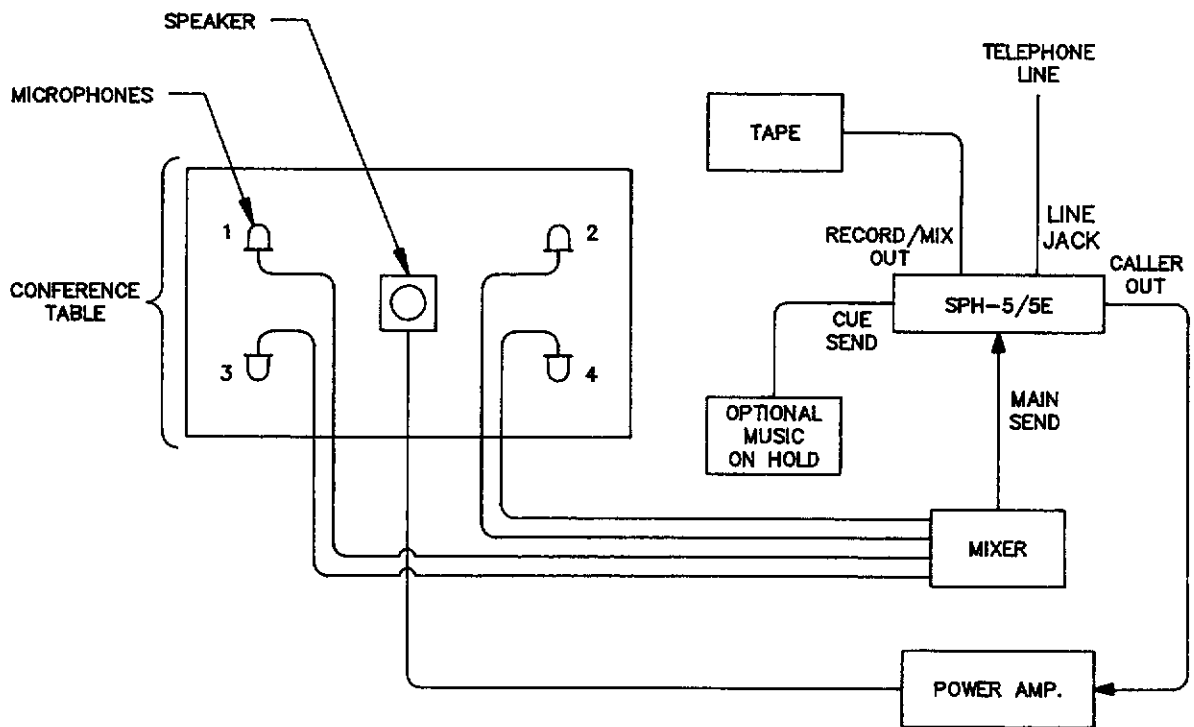

CONFERENCE ROOM SET-UP

Figure 33

5.5 Auditoriums or Large Meeting Rooms

The SPH-5/5E can be used to provide audio conferencing in an auditorium, church, arena or other large areas.

Using the configuration shown in **Figure 34**, the caller is heard through loudspeakers while anyone speaking on a microphone is heard by the caller.

This permits guests to speak at large meetings without requiring them to be on location.

NOTE: Proper acoustic treatment and careful placement of speakers with regard to microphone pickup patterns are essential. Careful planning initially will save considerable time and expense when compared to the "fix-it-later" approach.

The SPH-5/5E is adaptable to many different applications. If you need further assistance contact Gentner Customer Support.

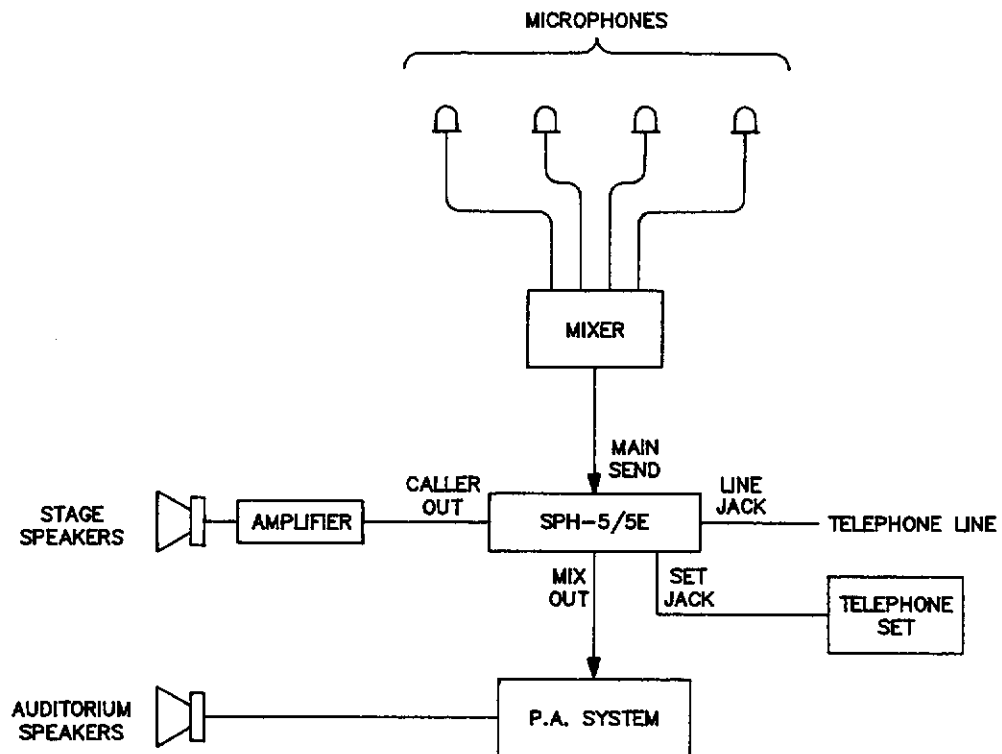

AUDITORIUM SETUP

Figure 34

5.6 Video Conferencing or Business Television Use

When using the SPH-5/5E for return audio in video conferencing, setup is similar to a broadcast application.

Many audio mixing consoles contain a mix-minus output for feeding telephone callers. This output should be applied to the Main Send XLR of the SPH-5/5E.

If your console does not contain a mix-minus output, you can use the output of the microphone mixer or the moderator's microphone preamplifier. Other audio sources are acceptable as long as they do not contain any of the caller's own audio.

The Caller output of the SPH-5/5E is connected to a separate input of the mixing console. The audio is then mixed with the main program feed and sent to the entire audience.

NOTE: Callers should be cautioned to turn down their television sets and listen to the program on the telephone line to avoid confusion from delayed transmissions and to avoid creating feedback from speakers.

If the conference involves a feed to an auditorium, with a guest panel or moderator on a stage, the SPH-5/5E's RECORD/MIX Output can be used to feed a separate power amplifier for sound reinforcement in the auditorium. The RECORD/MIX Output contains both sides of a telephone conversation.

Caution must be taken to ensure that the people on stage do not receive a feed containing their own audio, or feedback will occur.

Placing the SPH-5/5E in the HOLD mode switches from the MAIN SEND input to the CUE SEND input.

If you want to prevent the interruption of the audio feed from the microphone mixer to the P.A. amplifier, connect the microphone mixer to the CUE SEND input, and place front-panel DIP Switch 1 into the **up** position.

This changes the CUE SEND input to an AUXILIARY SEND input that does not toggle with the HOLD button.

The SPH-5/5E can be installed for use with a multi-line telephone set. In this case, a multiple line telephone set is used to select one caller at a time to send to the SPH-5/5E. For more information on multi-line installations, refer to Section 3.6 of this manual.

If your application requires combining multiple SPH-5/5E's for multi-line use, refer to Section 6.2 of this manual for illustrated instructions.

Contact Gentner Customer Support if you need assistance with your video conferencing applications.

SECTION SIX -- TYPICAL BROADCAST APPLICATIONS

6.1 Typical Broadcast Applications

Figure 35 shows how a typical broadcast station would use the Gentner SPH-5/5E Telephone Hybrid.

A multi-line telephone is used to select a telephone line to be routed to the SPH-5/5E. When the Talent is ready to put the call on the air, the ON button is pressed. The following then occurs:

- a) The selected phone line is terminated.
- b) The output audio is unmuted and the Caller audio is routed to the input of the console.

The muting function is useful in broadcast applications because it masks the termination pops and clicks, making telephone connection clean and clear.

When the CUE function is inactive, audio from the mix-minus output of the console is routed to the MAIN SEND audio input of the SPH-5/5E, and to the caller.

If the CUE function is active (CUE lamp is on), audio from the CUE SEND audio input (usually the announcer's microphone preamplifier output) is routed to the caller.

When the SPH-5/5E is OFF and the REC button is pressed, the SPH-5/5E will automatically activate the CUE mode. This function would commonly be used for recording conversations for playback at a later time.

If the SPH-5/5E is in the OFF mode, and the RECORD mode is activated, the REC button indicator will glow steadily indicating ready to record. Pressing the ON button will issue tape start and record enable commands. The REC button indicator will then flash.

While operating the SPH-5/5E in the RECORD mode, pressing either the OFF button or the REC button will stop the tape recorder via the Tape Stop relay.

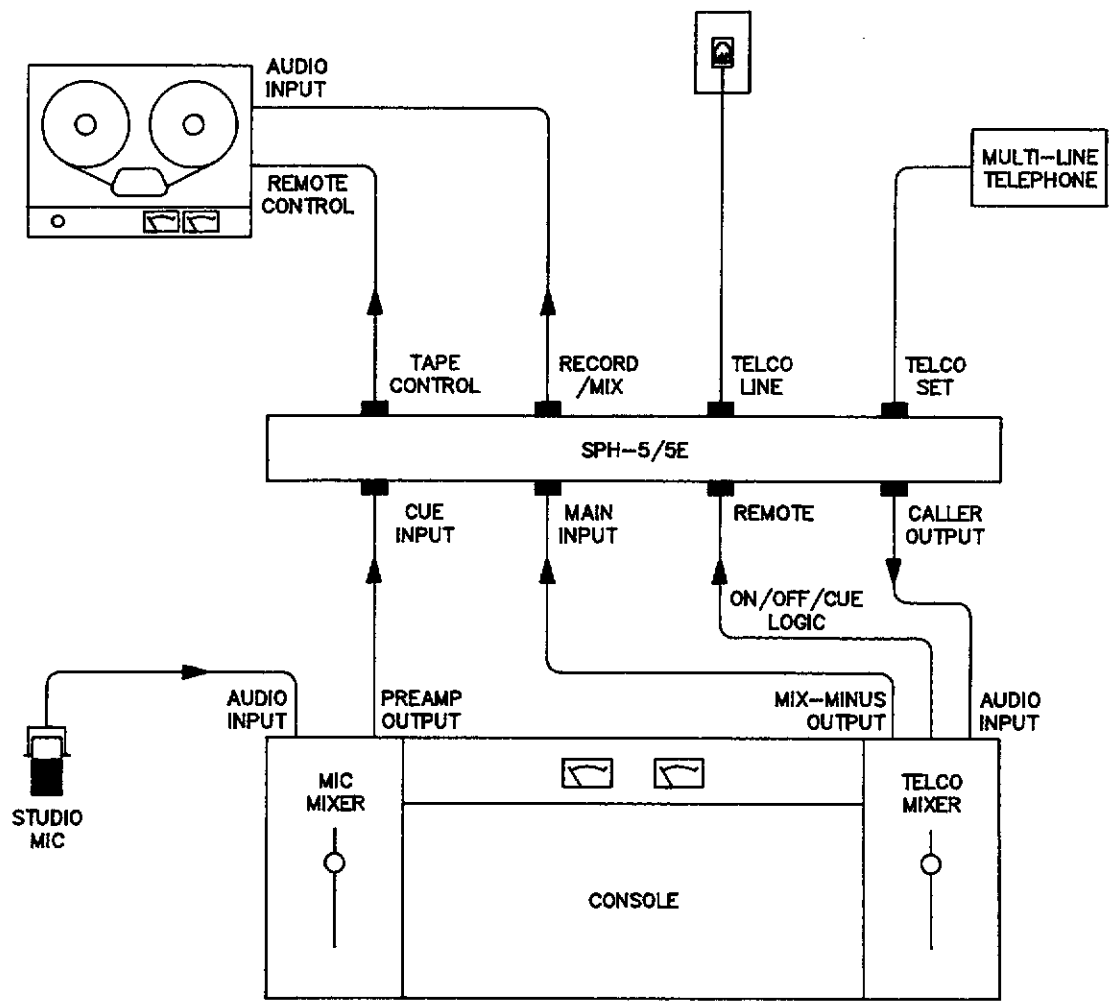

TYPICAL BROADCAST INSTALLATION

Figure 35

6.2 Conferencing Multiple SPH-5/5E Units

Multiple SPH-5/5E units can be conferenced for the airing of multiple callers or for use as a telephone conference bridge.

Figures 36, 37, and 38 show three methods of conferencing SPH-5/5E's for different applications.

Figure 36 shows a talk show application where an out-of-studio guest is to participate via a dedicated telephone line through a hybrid. A second hybrid, connected to a multi-line telephone, is conferenced to the guest hybrid.

In this configuration, both callers can hear the studio announcer and each other in a fully amplified conference.

Separate Caller and guest Caller audio signals are available for application to two console channels. With the use of the CUE function of the guest SPH-5/5E, off-air conversation can be held with the guest during breaks such as commercials, national news, or music.

Figure 37 shows two SPH-5/5E's that could be connected to either a dedicated telephone line or to multi-line call directors.

When connected to multi-line call directors, maximum flexibility in placing two callers in a fully amplified conference is achieved.

In this configuration, both callers would hear the studio announcer and each other. Separate Caller audio outputs are available for application to the mixing console.

Figure 38 shows two SPH-5/5E's in a conference setting where both Caller outputs are mixed together for application to one console input.

Additional units could be stacked, in a similar manner to those shown in **Figure 38**, depending on individual applications. If a particularly large architecture or unique application is desired, please contact Gentner Customer Support for assistance.

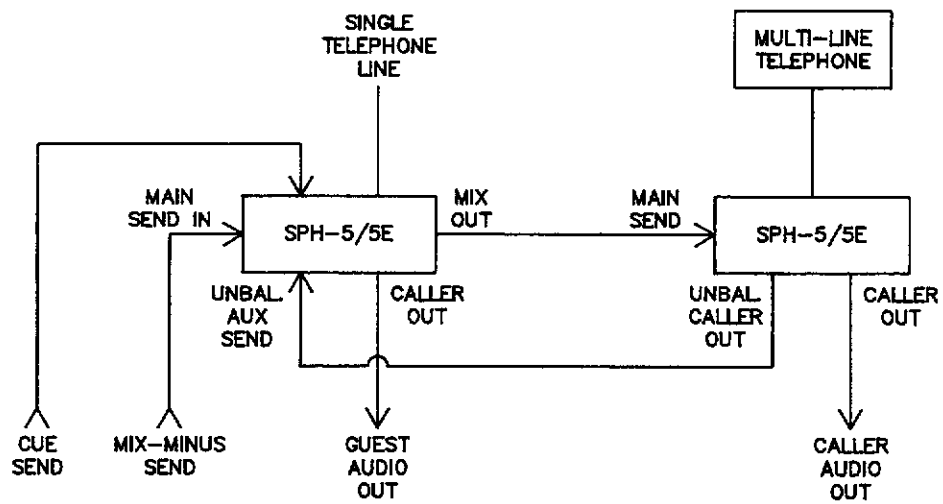

DUAL HYBRID SINGLE AND MULTI-LINE CONFERENCE

Figure 36

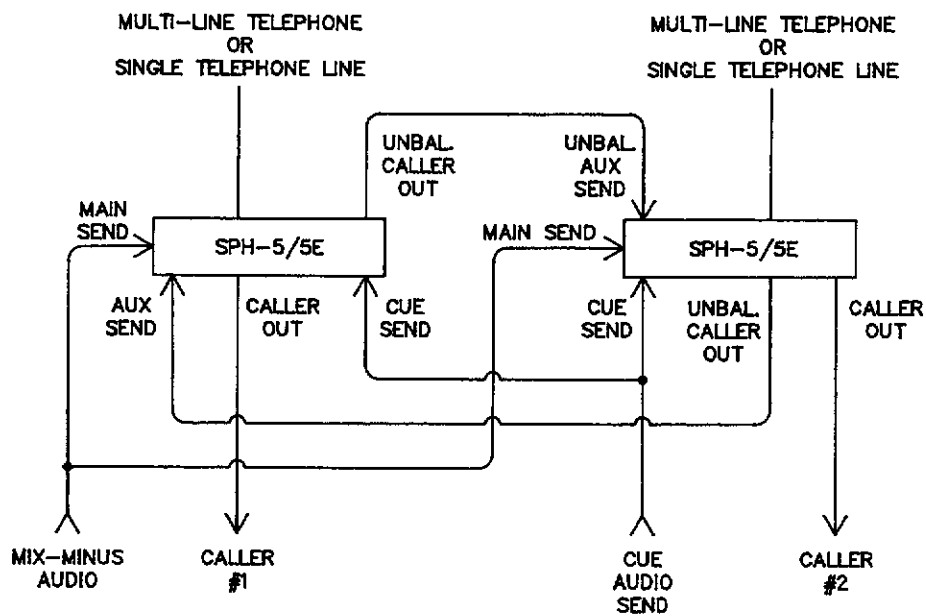

DUAL HYBRIDS WITH SEPARATE AUDIO OUTPUTS

Figure 37

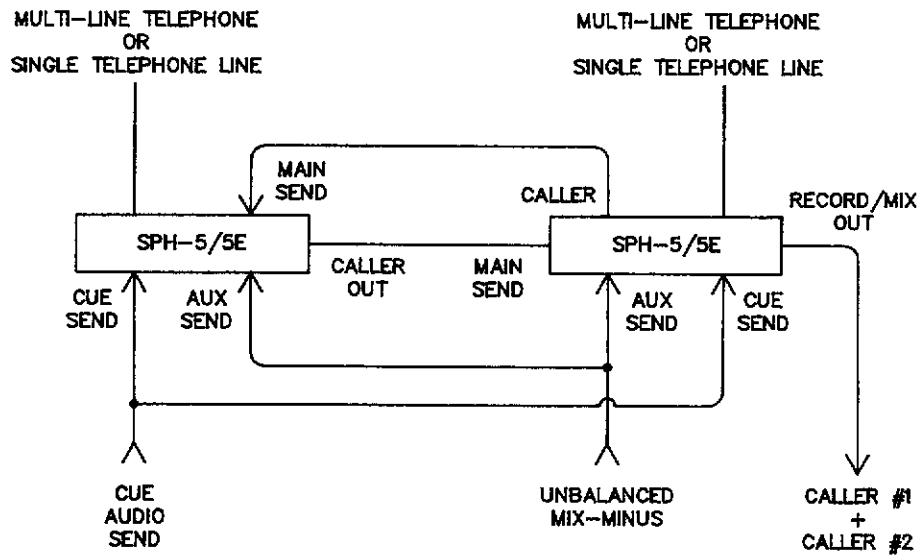

DUAL HYBRIDS WITH MIXED AUDIO OUTPUT

Figure 38

SECTION SEVEN -- THEORY OF OPERATION

7.1 Overview

The basic theory of operation for the Gentner SPH-5/5E Telephone Hybrid is divided into three general areas based upon signal flow:

- a) Send Audio Circuitry
- b) Caller (Receive) Audio Circuitry
- c) Telephone Interface Circuitry

Figure 39 of this section shows a functional block diagram of the SPH-5/5E. Schematic diagrams are found in Section 8.3 of this manual.

Connections that transfer from one sheet of the schematics to another are labeled with "Tags" which help to track signal flow through the schematics.

Examine the functional block diagram of **Figure 39** and refer to the schematics located in Section 8.3 while reading the discussion of circuit operation provided in this section.

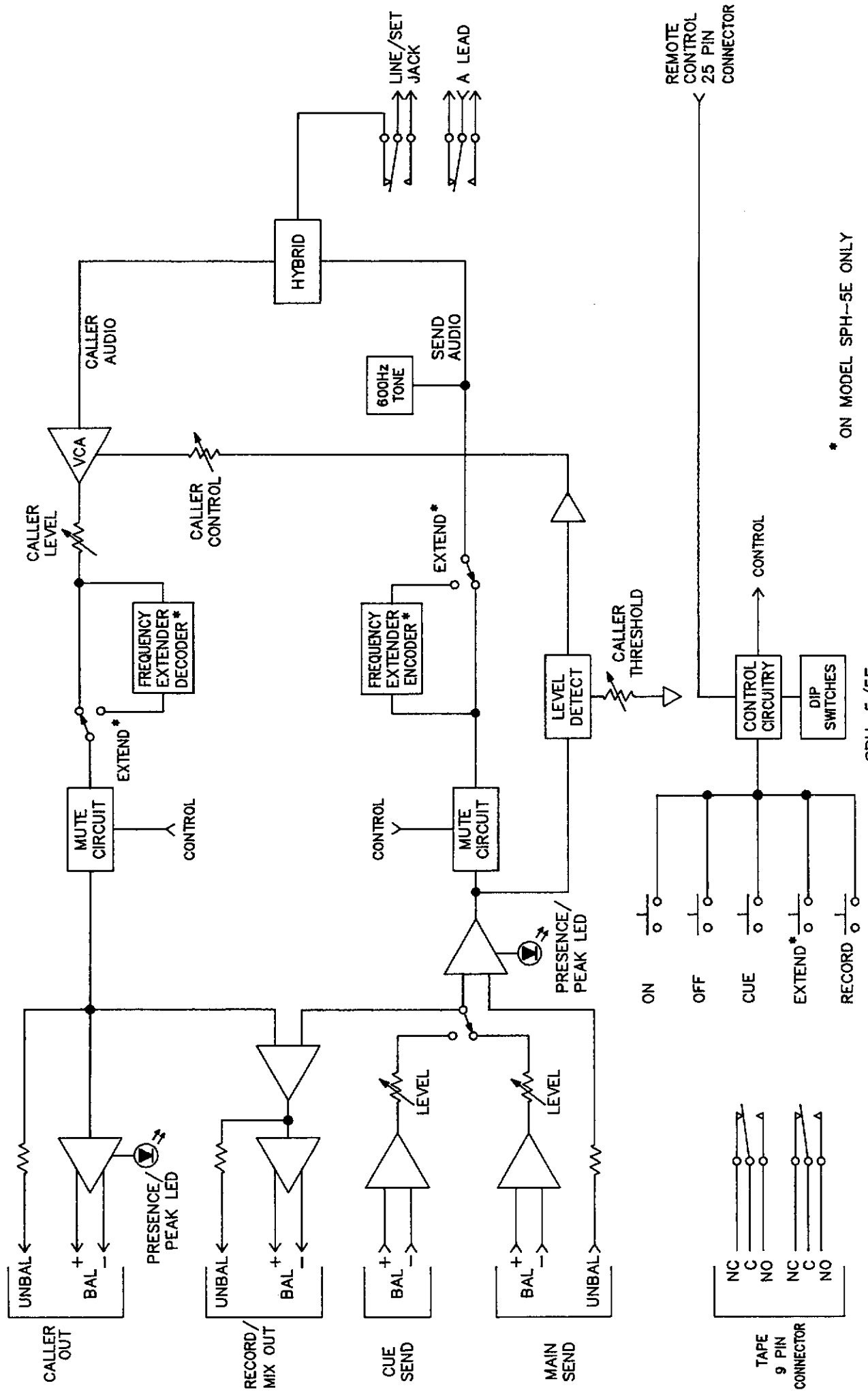

* ON MODEL SPH-5E ONLY

SPH-5/5E
FUNCTIONAL BLOCK DIAGRAM
Figure 39

7.2 Send Audio Circuit Description

The MAIN SEND input (J3) and the CUE SEND input (J4) are found on the left side of Sheet 1 of 12 of the schematic diagrams.

All audio connections on the SPH-5/5E are provided with RFI suppression, an example of which may be seen between the MAIN SEND and CUE SEND jacks and the buffer amplifiers, U2 and U3.

The MAIN SEND input passes through U2, is buffered, and converted to unbalanced audio. 13 dB of gain is provided by U25 and the MAIN SEND signal continues on to Sheet 2 of 12.

The CUE SEND input passes through U3, is buffered, and converted to unbalanced audio. 13 dB of gain is provided by U25 and the CUE SEND signal continues on to Sheet 2 of 12.

The switching between MAIN SEND and CUE SEND is carried out by U10, a quad bilateral switch on the left side of Sheet 2 of 12. The control for this switch comes from the PAL (U28) on Sheet 9 of 12 via the SND SEL tag.

The selected Send audio from U10 is buffered by U9 and feeds two summing amplifiers.

U9, Pin 8, Pin 9, and Pin 10 combines the Send audio with the Caller audio. The resultant RECORD/MIX unbalanced output passes through RFI filtering and appears at the Remote connector, J7, pins 11 and 24. Amplifier U4, Pin 1 through Pin 7 provide the same RECORD/MIX output in a balanced form, which, after RFI filtering, appears at XLR connector J5.

The other summing amplifier, U9, Pin 5, Pin 6, and Pin 7, combines the selected Send audio, the unbalanced AUXILIARY SEND audio (from Remote connector, Pin 9), and the Test Tone (when enabled). The output of this summing amplifier is routed to Sheet 3 of 12.

NOTE: K5 is used only on the SPH-5E Telephone Hybrid which includes frequency extension. K5 is the encode/decode relay. On the SPH-5/5E, jumpers are used to route the audio from pin 4 to 6 and from pin 13 to 11 of the socket for K5.

On the right side of Sheet 3 are the SEND PRESENCE and CALLER PRESENCE indicator circuits. Simple comparators switch on one-shot U27 (Send Presence) and U31 (Caller Presence) when the appropriate reference level has been exceeded. This in turn drives transistors Q1 through Q4 to illuminate the red/green display LED's as needed.

Continuing the signal path from the Caller CONTROL tag on the left side of Sheet 3 of 12, the selected Send audio proceeds to Sheet 4 of 12 which includes the Caller CONTROL and Send Mute circuitry.

The audio is rectified and compared to a reference level determined by the setting of R218, the front-panel CALLER CONTROL THRESHOLD Pot. The amount of attenuation to be provided is determined by the setting of R217, the CALLER CONTROL Pot. The control voltage passes from U26 to the VCA (U19) where the appropriate reduction (dimming) of Caller Audio takes place.

The Send MUTE is a quad bilateral switch controlled by the PAL on Sheet 11 of 12 via the SM tag. When the audio is not muted, it passes to the Send filter shown on Sheet 7 of 12.

This filter is a four-pole, high-pass filter designed to roll off low frequencies below 270 Hz.

From the high-pass filter, Send audio is routed simultaneously to two separate low-pass filters. The choice of filters is a user option. With JP2 closed (shown on the lower right corner of Sheet 7 of 12) the full telephone bandwidth to 3300 Hz is passed before significant roll-off. With JP1 closed, Send audio band-width is limited to 2500 Hz. This provides a 2 to 3 dB improvement in hybrid null performance as measured with pink noise.

After bandwidth selection, Send audio is routed back to Sheet 6 of 12 via the Send FILTER OUT tag. There, U7 provides limiting to keep the Send audio feeding the telephone line from exceeding -9 dBm. An RF filter follows and the hybrid function is performed by the two PREM transformers and the front-panel hybrid null R/C network adjustments shown on the upper right corner of Sheet 6 of 12.

7.3 Caller Audio Circuit Description

Caller audio passes from the telephone line through K1 on Sheet 6 of 12, then passes through the PREM transformers, and some RFI filtering, and exits Sheet 6 of 12. Caller audio continues to Sheet 5 of 12 via the CALLER FILTER IN tag.

The Caller band pass filtering is comprised of elliptical 4-pole high-pass and 4-pole low-pass filters. The effective pass band extends approximately from 270 Hz to 3.3 kHz.

Also at the output of the Caller filtering is a buffer amplifier which drives the front-panel hybrid null adjustment TEST Points.

From the output of the Caller band pass filter, audio is routed via the CALLER FILTER OUT tag to the upper left corner of Sheet 4 of 12 where it passes through the VCA for Caller CONTROL action as described in Section 7.2.

The Caller audio from the VCA passes through U18 and continues to Sheet 3 of 12 via the Caller ADJUSTED tag.

Following the front-panel CALLER LEVEL adjustment pot, the audio is sampled for the CALLER PRESENCE Indicator, and proceeds to K5 (only used on the SPH-5E) and is transferred to Sheet 2 of 12 via the Caller OUT tag.

Unbalanced CALLER Output is brought out on pins 10 and 23 of the REMOTE connector. Amplifier U5 balances the Caller Output appearing at XLR connector J6. RFI filtering is provided on all outputs.

U9 combines the Caller audio with the selected Send audio. The resultant unbalanced RECORD/MIX output appears at the Remote connector between pins 11 and 24. Amplifier U4 balances the RECORD/MIX output appearing at XLR connector J5. RFI filtering is provided on these outputs.

7.4 Telephone Interface Circuit Description

Please refer to Sheet 6 of 12 of the schematic diagrams found in Section 8.3 of this manual while reading the following.

The TIP and RING conductors of the telephone line are applied to J1. This is an RJ11C connector on the rear panel of the SPH-5/5E.

TIP and RING are then routed through fusing resistors to line relay K1.

When K1 is not energized, the telephone line TIP and RING are routed directly to the Set Jack, J2. When K1 is energized, Tip and Ring are routed past TZ1 and TZ2 which provide surge protection in conjunction with R1 and R2. This protects the hybrid from surges on the telephone line such as those caused by lightning.

The hybrid null adjustment is accomplished by proper settings of SW1 and R219 (shown on the upper right corner of Sheet 6 of 12). The capacitive reactance value selected by SW1 and resistance value as adjusted by R219 are balanced to provide the maximum separation with the PREM transformers.

SECTION EIGHT -- MAINTENANCE

8.1 SPH-5/5E Telephone Hybrid Maintenance

Your Gentner SPH-5/5E is a highly reliable device. It was thoroughly tested at the factory before being shipped to you.

To protect your SPH-5/5E from damage, do not operate it in an excessively hot or cold environment and avoid subjecting the unit to physical shock.

If you leave your SPH-5/5E permanently connected to a telephone line, it is strongly recommended that you provide external surge protection for the telephone line and the AC power input.

Gentner can provide highly reliable surge protection devices for both the telephone lines and the AC power input. Call Gentner for more information.

WARNING: THE SPH-5/5E CONTAINS CMOS INTEGRATED CIRCUITS. ALL SERVICE TO THE UNIT MUST BE PERFORMED IN A STATIC FREE ENVIRONMENT.

Should your unit not operate satisfactorily, please contact Gentner Customer Support.

8.2 Questions and Answers

This section is intended to answer the most common questions about installation and operation of the Gentner SPH-5/5E.

If you need further assistance, call Gentner Customer Support.

Question: The Caller level coming into my console is too low (or too high) and I have to run the pot unusually high (or low). Do I need additional amplification (or attenuation)?

Answer: Perhaps, but first try adjusting the CALLER LEVEL trim pot located behind the removeable front access panel. See Section 4.4 of this manual.

Question: What is the difference between the CALLER CONTROL and the CALLER THRESHOLD CONTROL?

Answer: The CALLER THRESHOLD CONTROL sets the amount of Send level that is required to begin reducing (dimming) Caller level. The CALLER CONTROL determines how much the Caller audio is reduced (dimmed).

Question: My SPH-5/5E gates the Caller audio like a speakerphone. Should it do this?

Answer: When the CALLER CONTROL trim pot located inside the front access panel is in the full clockwise position, the effect can be like that of a speakerphone. With the CALLER CONTROL trim pot set at the full counter-clockwise position, no reduction (dimming) of Caller audio will take place. See Section 4.4 for details.

Question: Whenever there is the slightest sound in the studio, the Caller CONTROL attenuates (dims) the Caller. How can I correct this?

Answer: The CALLER THRESHOLD CONTROL is located inside the front access panel, and is used to adjust the amount of Send audio required to initiate Caller audio reduction (dimming). Try adjusting the CALLER THRESHOLD CONTROL as described in Section 4.4 of this manual.

Question: I have installed remote toggle switches to control the ON and OFF functions of the SPH-5/5E, but now I can't turn off the unit after it is turned on. Also the front-panel OFF button doesn't work properly.

Answer: Check the setting of DIP Switch 5 located behind the front access panel. With any latching ON/OFF switching configuration, DIP Switch 5 should be placed in the **up** position. When using the latching ON/OFF switching, no remote off switch is used, and the front-panel ON/OFF button on the SPH-5/5E will not operate normally. Refer to Section 4.5 for more information.

Question: I have hooked up a cassette deck to use as a "skimmer" to record all telephone calls. I connected the remote TAPE START contacts of the SPH-5/5E to the remote Pause connections on the cassette deck. I can't get the tape to roll. Is an interface necessary?

Answer: Probably not. Since your application requires a latching remote start closure, place front-panel DIP Switch 3 in the **up** position. These are dry relay contact closures fully compatible with your cassette deck.

Question: All I get out of the SPH-5/5E is a loud tone. Is there something wrong with the unit?

Answer: Check the setting of front-panel DIP Switch 2. This should be in the **up** position except when adjusting the hybrid null as described in Section 4.2 of this manual.

Question: I want to hook up the remote CUE function of the SPH-5/5E, but I can't get it to operate properly. What should I do?

Answer: When console logic is to select the CUE function, Pin 8 and Pin 5 of the REMOTE connector are used. A latching closure between these pins enables the CUE function.

The remote CUE connection at Pin 4 is for momentary remote operation identical to the front-panel CUE button on the SPH-5/5E. Please refer to Section 3.12 of this manual.

Question: I get feedback during audio conferences when I try to turn up the caller's level. What should I try?

Answer: Make certain that the hybrid null setup procedure described in Section 4.2 has been accomplished.

Try re-locating the microphones and/or speakers, if possible. Careful placement of speakers with regard to the microphones' pickup patterns is essential.

Additional acoustic treatment may be helpful.

Question: I'm using the SPH-5/5E on my PBX. The signal-to-noise ratio (SNR) and hybrid performance is poor. Why?

Answer: The SPH-5/5E reduces line noise by using a band pass filter to limit extraneous low and high frequencies coming in on the telephone line. Therefore noise which falls within the band pass range will not be filtered out. One such source on digital telephone systems is the CPU noise induced into adjacent audio wires in a cable.

Hybrid performance can be severely degraded when something other than the telephone central office hybrid is seen by the SPH-5/5E. When other inductive or capacitive components such as switches, relays, chokes, or transformers are added to the circuit, it becomes much more difficult for the hybrid to match the line characteristics.

Hybrid performance may be improved somewhat on the SPH-5/5E by reducing the Send audio band pass filter. An internal jumper must be repositioned to do this. See Section 4.6 for information and instructions regarding this jumper.

Wide variance between optimum Send and Caller (receive) levels can also degrade hybrid performance. For some applications, using an outside telephone line which bypasses the PBX is the only way to achieve satisfactory performance.

Question: My SPH-5/5E needs to put louder Send audio on the telephone line. What can I do?

Answer: Try adjusting the MAIN SEND and/or CUE SEND input level trim pots as needed. Please note that a level of -9 dBm sent down the telephone line is the maximum permitted by the FCC. See Section 4.3 of this manual for instructions for adjusting these trim pots.

Question: Callers report there is quite a difference in Send level when the caller is placed on-the-air. I have tracked it down to a change of level that occurs whenever the CUE function is activated or deactivated. What can I do to fix this?

Answer: Try adjusting the CUE SEND level to match that of the MAIN SEND. See Section 4.3 of this manual for instructions for adjusting these trim pots.

Question: Is it OK to do a "button-mash" conference, that is, direct more than one telephone line to the SPH-5/5E at a time?

Answer: "Button-mash" conferences can be done, but much better results can be achieved by using multiple hybrids.

8.3 Schematics

A set of schematic diagrams for the SPH-5/5E unit is presented on the following pages.

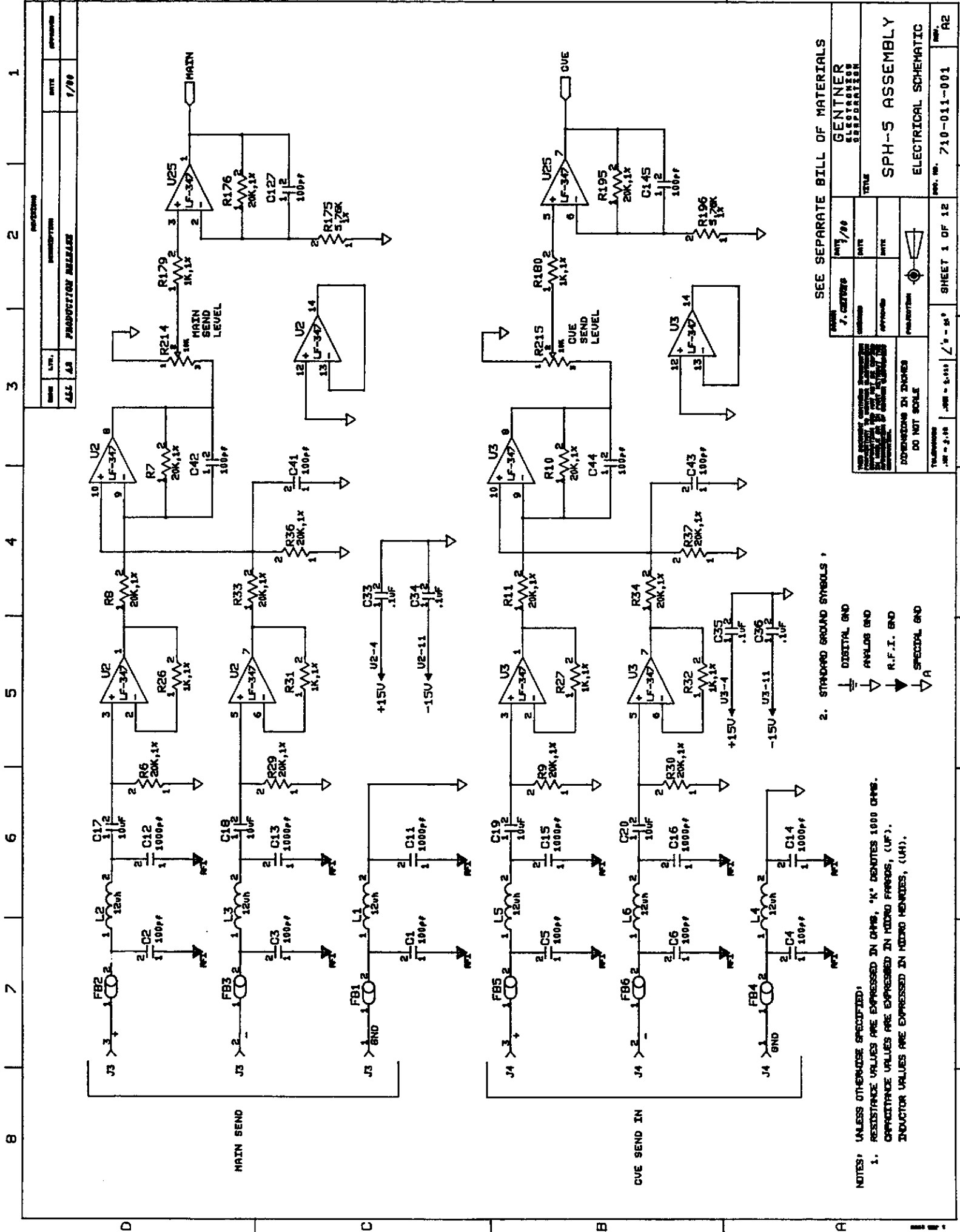

REV	DATE	DESCRIPTION
451	1/79	PRODUCTION RELEASE

REV	DATE	DESCRIPTION
451	1/79	PRODUCTION RELEASE

NOTES: UNLESS OTHERWISE SPECIFIED:
 1. RESISTANCE VALUES ARE EXPRESSED IN OHMS, 'K' DENOTES 1000 OHMS.
 CAPACITANCE VALUES ARE EXPRESSED IN MICRO FARADS, (UF).
 INDUCTOR VALUES ARE EXPRESSED IN MICRO HENRIES, (UH).

2. STANDARD GROUND SYMBOLS:

SEE SEPARATE BILL OF MATERIALS

REV	DATE	DESCRIPTION
7	7/79	7. CANCELS
8		
9		
10		
11		
12		
13		
14		
15		
16		
17		
18		
19		
20		
21		
22		
23		
24		
25		
26		
27		
28		
29		
30		
31		
32		
33		
34		
35		
36		
37		
38		
39		
40		
41		
42		
43		
44		
45		
46		
47		
48		
49		
50		

SEE SEPARATE BILL OF MATERIALS

REV	DATE	DESCRIPTION
7	7/79	7. CANCELS
8		
9		
10		
11		
12		
13		
14		
15		
16		
17		
18		
19		
20		
21		
22		
23		
24		
25		
26		
27		
28		
29		
30		
31		
32		
33		
34		
35		
36		
37		
38		
39		
40		
41		
42		
43		
44		
45		
46		
47		
48		
49		
50		

DO NOT SCALE

TRANSMISSION

SCALE: 1/8" = 1" 1/8" = 25'

SHEET 1 OF 12

710-011-001

SPH-5 ASSEMBLY

ELECTRICAL SCHEMATIC

GENTNER SYSTEMS CORPORATION

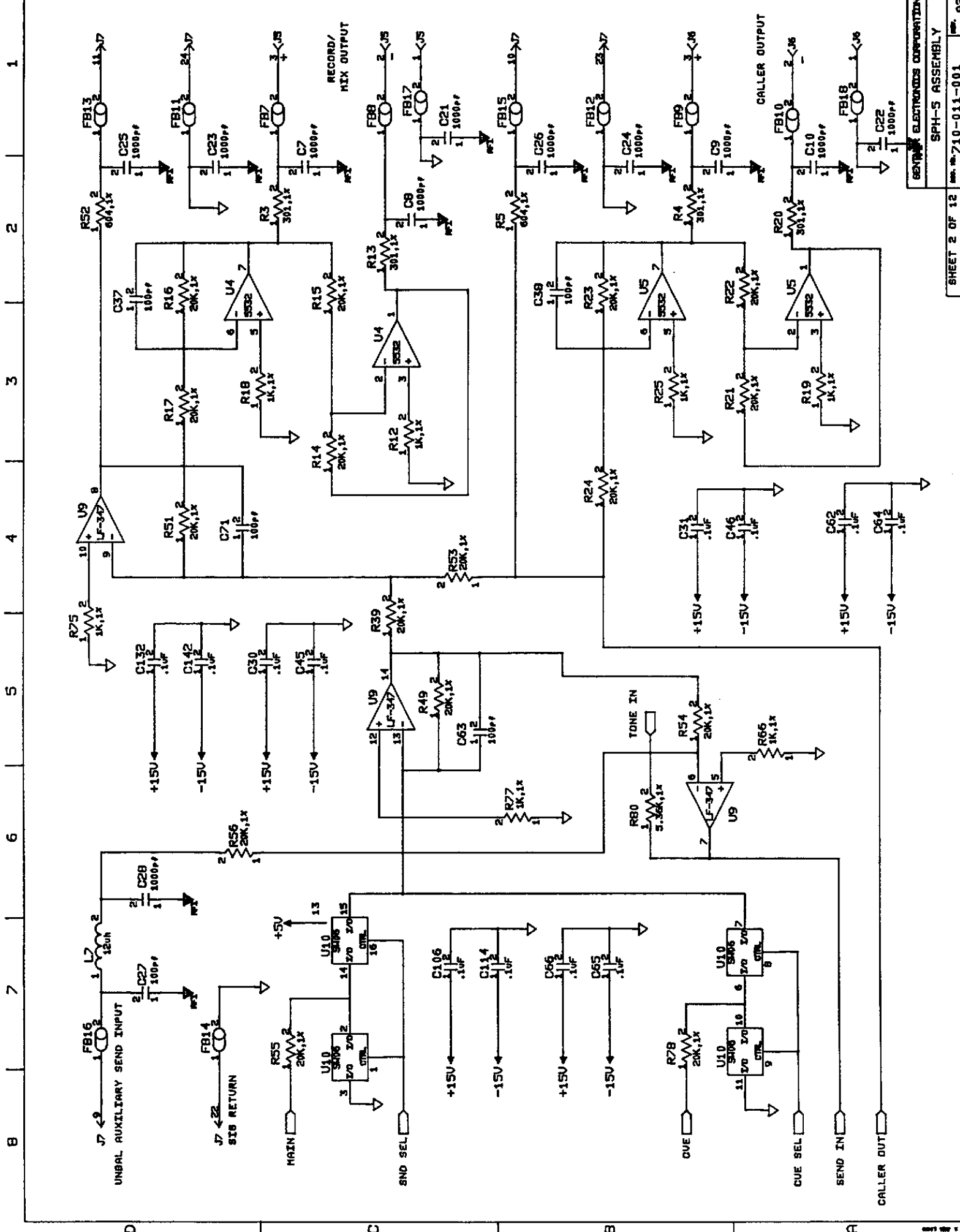

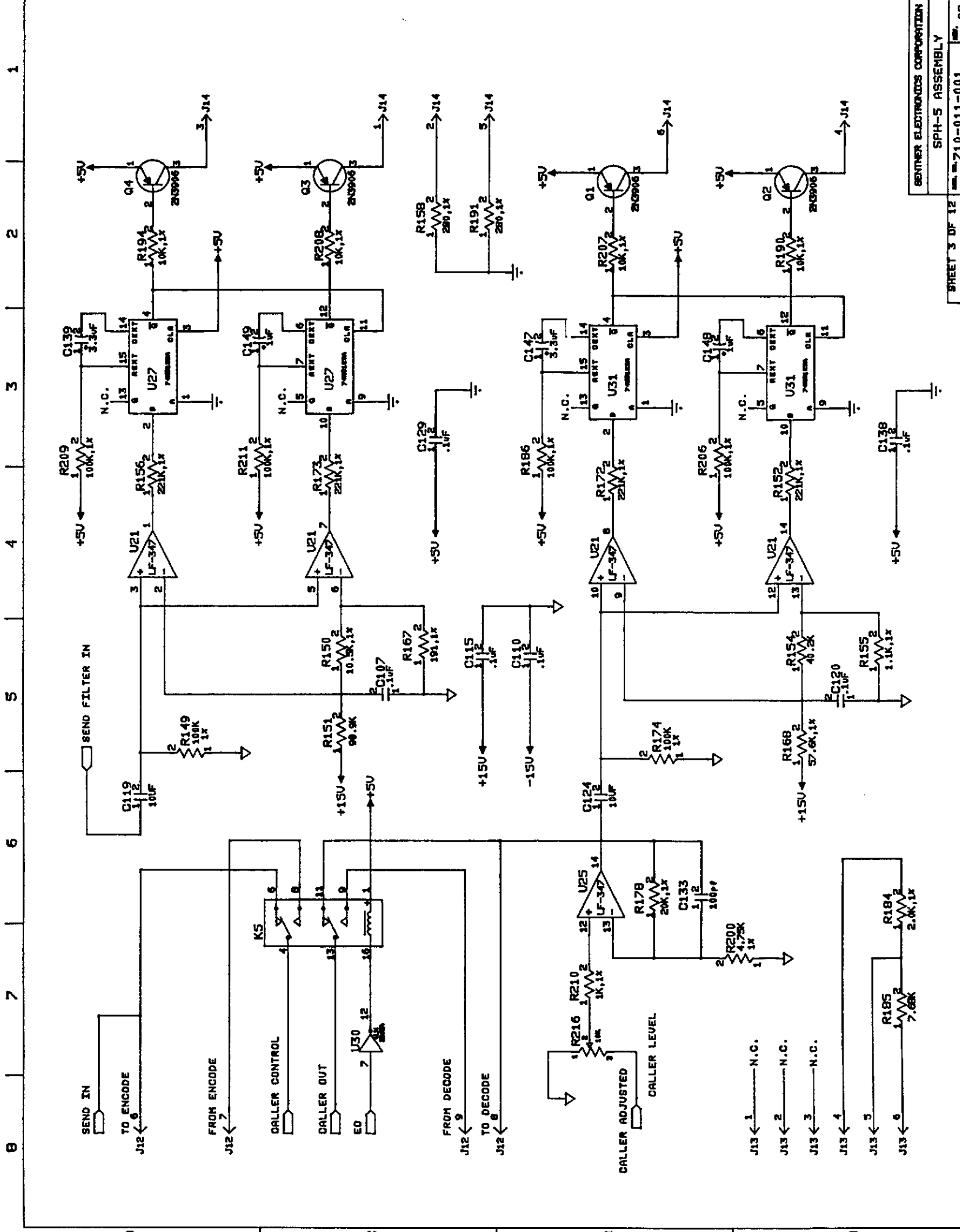

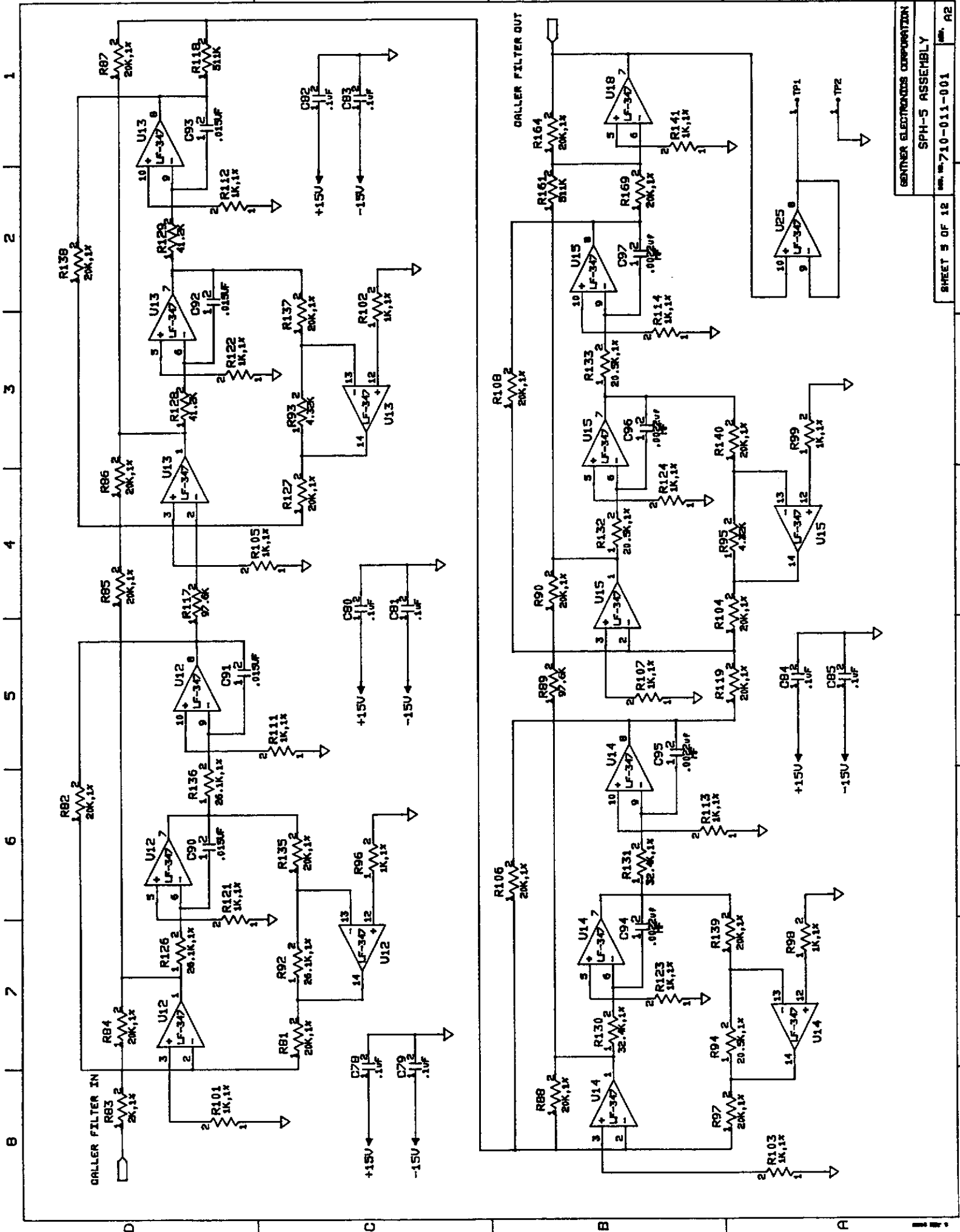

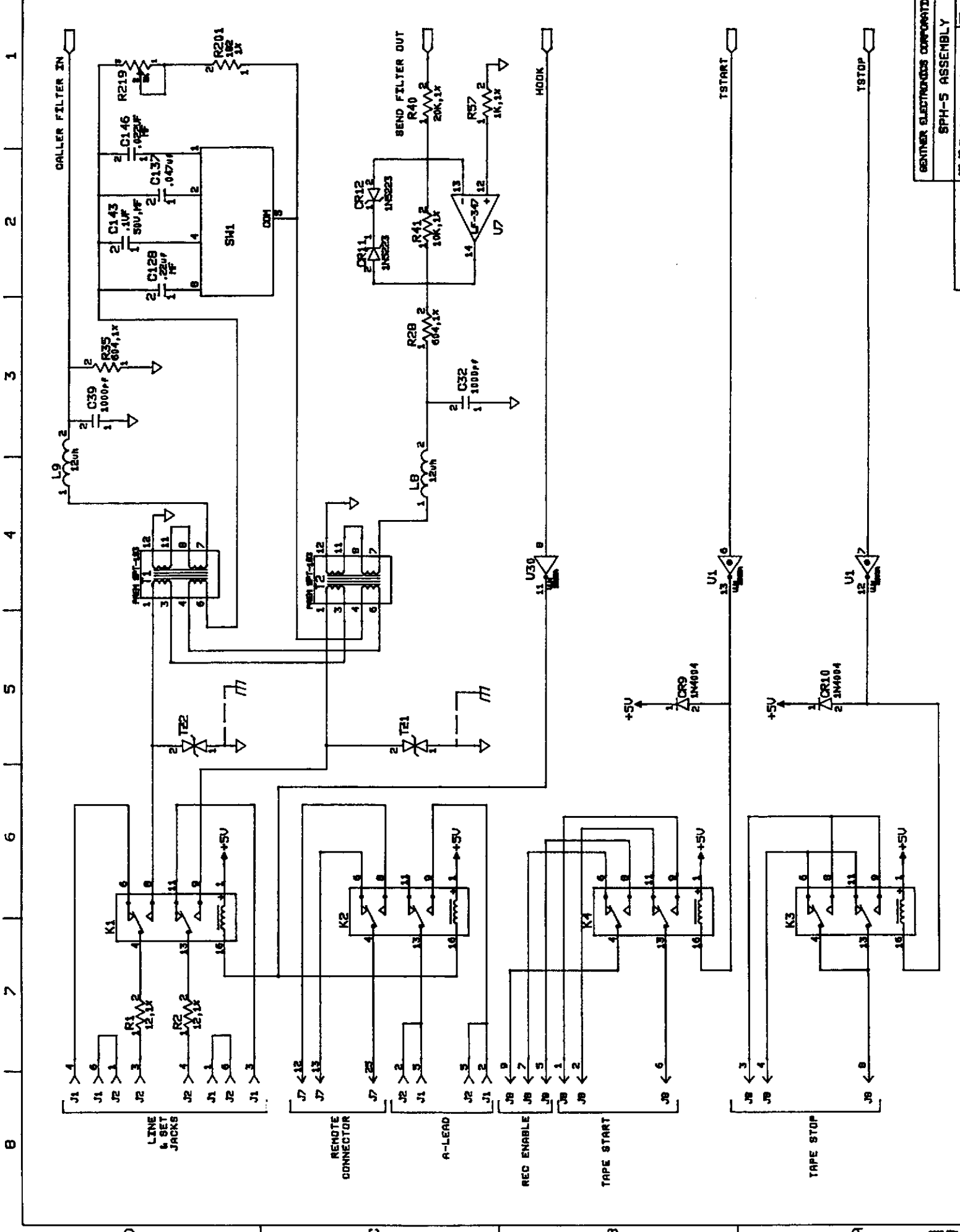

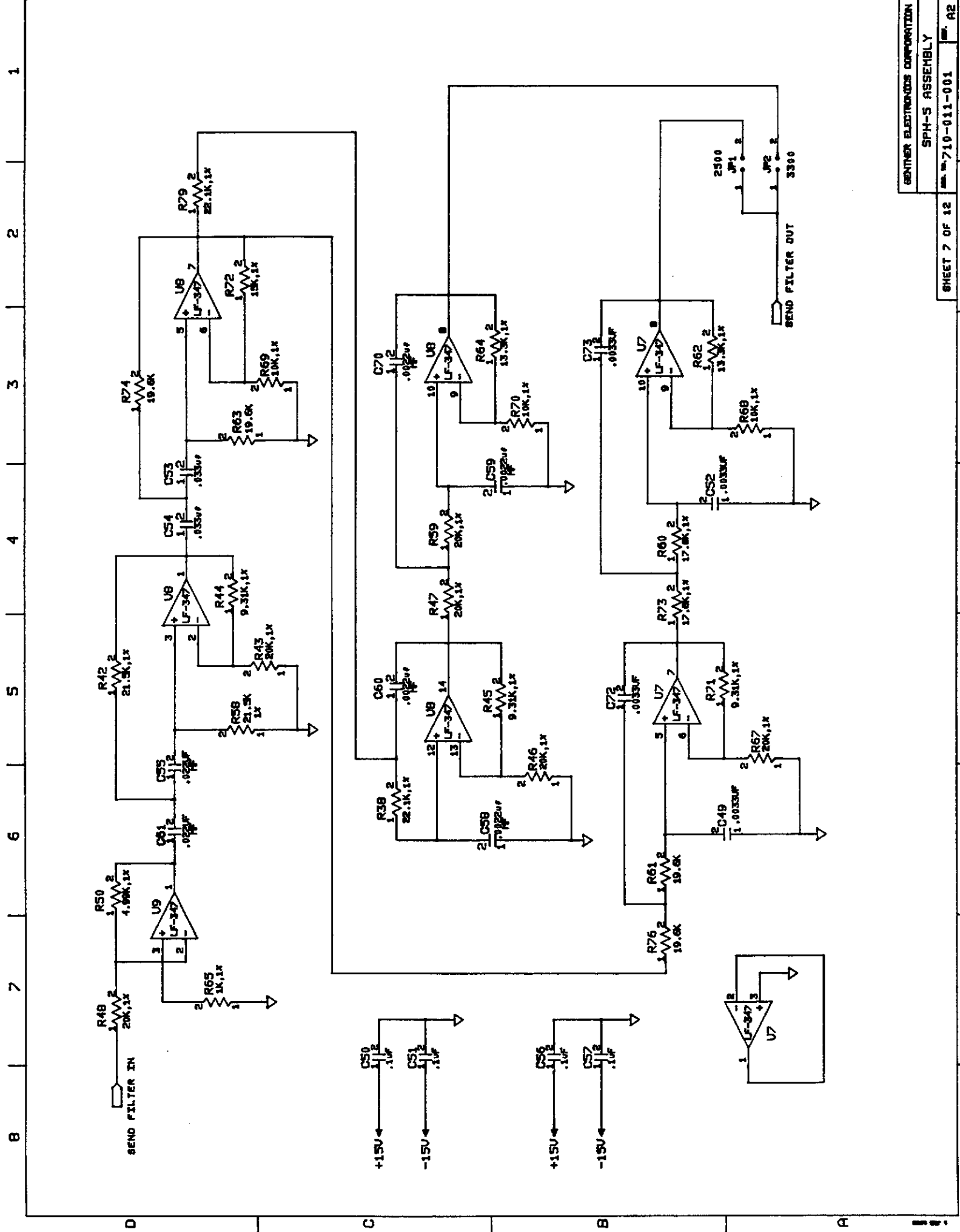

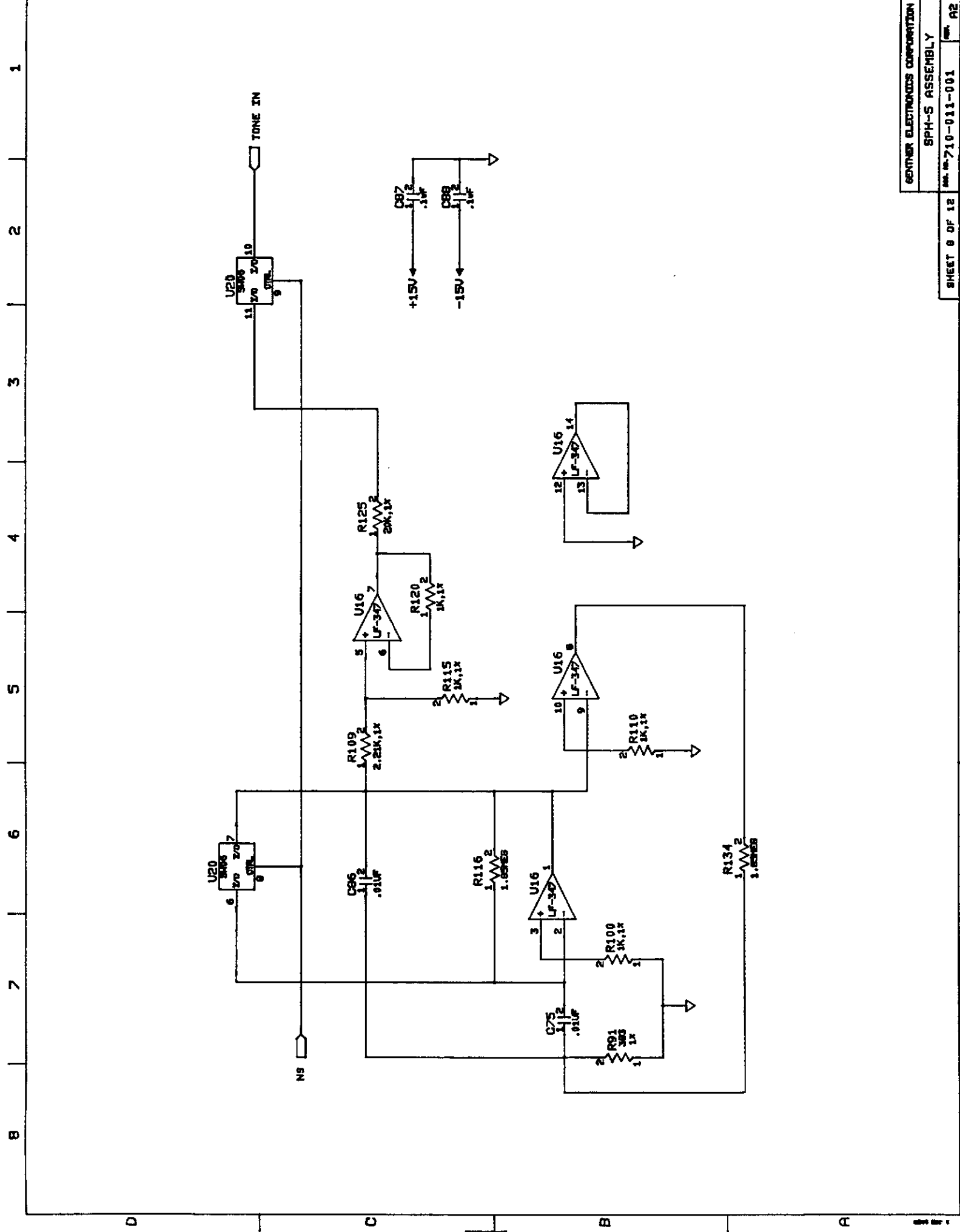

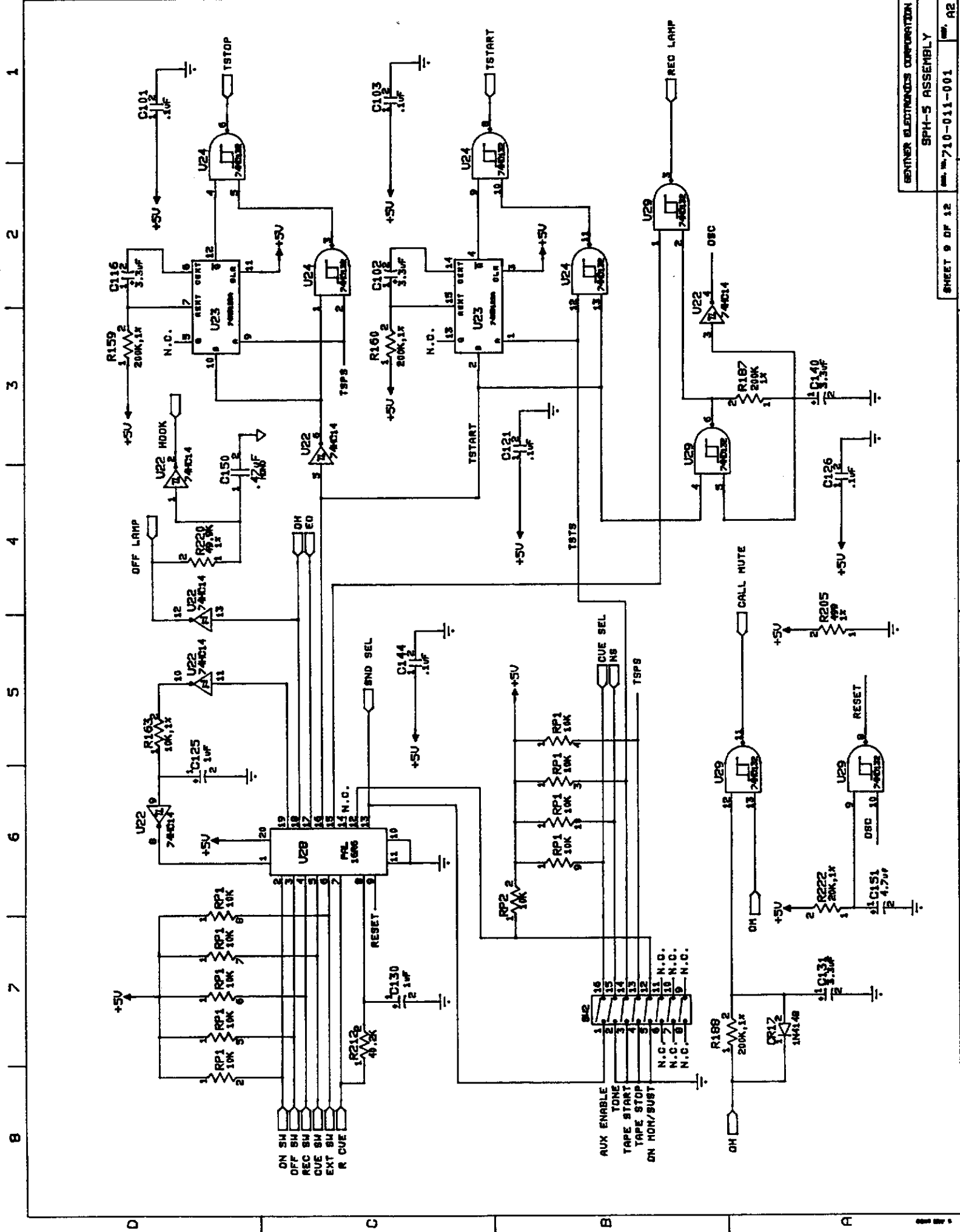

8 7 6 5 4 3 2 1

REMOTE BUTTON COMMON

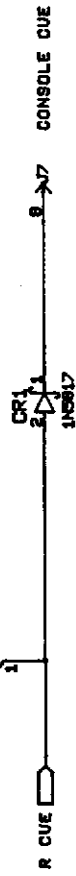
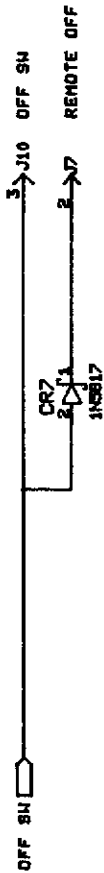
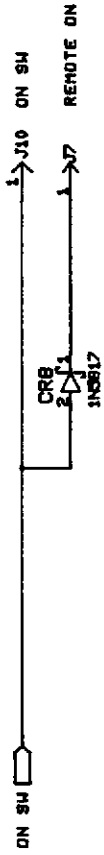

1 2 3 4 5 6 7 8

