

GT1524



Single Channel Echo Canceller

Installation & Operations Manual

Gentner.

Perfect Communication through Technology, Service, and Education.™

GT1524 Installation and Operations Manual
Gentner Part No. 800-114-101 (Rev 1.0)
October 1999

©1999 Gentner Communications Corporation. All Rights Reserved. Gentner Communications Corporation reserves specification privileges. Information in this manual is subject to change without notice or obligation.
Manual Development: Scott Sorenson, Wayne Whiteley, Mike Raymond
Artwork and Illustrations: Laurie Lingmann, Mike Raymond

This equipment complies with the requirements of the European guidelines:

89/336/EEC "Electromagnetic Compatibility"
73/23/EEC "Electrical operating material for use within specific voltage limits"
98/482/EC "Single terminal connection to the public switched telephone network."

Conformity of the equipment with the above guidelines is attested by the CE mark.



Gentner[®]

T able of Contents

1. Introduction	.3
Unpacking	4
2. Overview	.5
About the GT1524	5
Applications	6
Product description	6
Front Panel	9
1. LCD Window	9
2. Enter Button	9
3. Up/Down Buttons	9
4. Escape Button	9
5. LED Meter	9
6. Meter Button	9
7. On Button	9
8. Off Button	10
Back Panel	10
1. Power	10
2. Line Out, Aux Out	10
3. 4-wire Video Codec In/Out	10
4. Mic/Line In, Aux In	10
5. RS232	10
6. Control/Status	10
7. Speaker	11
8. Telco Line	11
9. Telco Set	11
Equipment Placement	11
Telephone Line Requirements	11
3. Installation	.13
Room Planning	13
Acoustics	13
Reverberation	14
Acoustic Echo	14
Ambient Noise	14
Acoustic Room Treatment	14
Microphone Selection	15
Tabletop	15

Podium	15
Lavaliere	15
Microphone Placement	16
Conference Room Layout	16
Equipment Interconnections	17
Back Panel Connections	18
LCD Programming	20
Menu Trees	20
Moving Among Menu Items	20
Adjusting a Value	21
Menu Tree Diagram	22
Parameters Worksheet	23
Input Parameters	24
Gain Adjust	24
Mic/Line Input	24
Mute	24
Phantom Power	24
AGC	24
High-Pass Filter	24
Echo Canceller	24
NLP Adjust	24
From Telco and 4-Wire In	24
Gain Adjust	24
Mute	25
AGC	25
Output Parameters	25
Gain Adjust	25
Mute	25
System Parameters	25
Lock Panel	25
Set Passcode	26
RS232	26
Baud	26
Flow control	26
Telco	26
Auto Answer On/Off	26
Auto Disconnect	26
Unit ID	26
Meter Parameters	27
Timeout	27
4. Operation	29
Front Panel	29
Controlling Volume	29
Muting	29
Muting/Unmuting Input/Output	29

Answering a Call30
Making a Call30
Disconnecting a Call30
Custom Controller Options30

Appendices33

Appendix A: Specifications33
Appendix B: Connector Pinouts35
Appendix C: Serial Port Commands36
Appendix D: Compliance Statement48

1 Introduction

Sophisticated equipment makes the difference between an average (or even frustrating) meeting and a productive, effectively managed meeting. The GT1524 provides advanced, easy-to-use conferencing capabilities to make distance conferencing seamless and simple.

The GT1524 provides the highest possible audio quality available in a single channel echo canceller. It features an integrated telephone interface that enables telephone participants of an audio- or videoconference to sound as if they are actually in the same room. Plus, it features simultaneous two-wire/four-wire operation so you can audioconference and videoconference at the same time. And there's no white noise set-up—the GT1524 adapts automatically.

The GT1524 performs a variety of complex, integrated audio functions using digital signal processors (DSPs). Adjustments in level and other functions can be made via front panel programming, activation through a closure on the rear panel, or an RS232 serial interface.

The integrated telephone interface provides the GT1524's audioconferencing capability and can be customized to suit your needs. It can be set to automatically answer upon detection of a valid ring and automatically disconnect on loop drop or call progress tones. The GT1524 includes a built-in five-watt power amp.

If you need technical help on setting up your GT1524, please contact us at:

Telephone: 1.800.283.5936 (USA) or 1.801.974.3760

Fax: 1.800.933.5107 (USA) or 1.801.977.0087

Internet: www.gentner.com

E-mail: tech@gentner.com

Gentner Communications Corporation
1825 Research Way, Salt Lake City, UT 84119

Unpacking

Ensure that the following items were received with your shipment:

! **Gentner Communications is not responsible for product damage incurred during shipment. You must make claims directly with the carrier. Inspect your shipment carefully for obvious signs of damage. If the shipment appears damaged, retain the original boxes and packing material for inspection by the carrier. Contact your carrier immediately.**



GT1524
Part 910-114-101

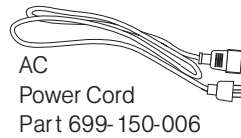

AC
Power Cord
Part 699-150-006



12-foot Telephone Cable
Part 830-000-012



Phoenix Push-On
Blocks (x6)
Part 673-016-003

Figure 1. Unpacking Your GT1524



GT1524 Installation
and Operations Manual CD
Part 800-114-101

Optional

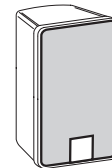

Speaker
Part 910-103-010



Microphones
Part 910-103-160 or
910-103-161
Mic Cables included
(shown below)

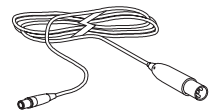

Please register your GT1524 online by visiting Gentner Technical Support on the World Wide Web at <http://www.gentner.com>. When your product is properly registered, Gentner Communications will be able to serve you better should you require technical assistance or desire to receive upgrades, new product information, etc.

2 Overview

About the GT1524

- Easy to install, simple to operate.
- No white noise set-up.
- Easy design, programming, installation and maintenance.
- Simultaneous two-wire/four-wire capability enables video and telephone participants to communicate simultaneously with full-duplex audio.
- Each input incorporates automatic gain control to compensate for loud or soft talkers, while the mic/line input offers high-pass filtering to reduce unwanted low frequency noise.
- Integrated touch-tone dialing for easy dialing through remote control.
- Gentner's Digital Signal Processing technology ensures crystal-clear audio with the deepest, most reliable hybrid null.
- 8kHz sampling rate allows continual adaptation to telephone-line conditions.
- Acoustic EC (single channel) >120 mS. DSP bases.
- Full-time Telco echo cancellation with 31 millisecond tail time.
- Selectable auto-answer and auto-disconnect enables integrators to choose auto-disconnect without auto-answer and vice versa.

- Lockout front panel access for security.
- Phoenix™ push-on blocks make pin-for-pin wiring easier.
- Worldwide compliance includes FCC, CSA and CE.
- Mountable in a single 19" rack space.

Applications

The GT1524 is perfect for audioconferencing or for providing audio for videoconferencing with a single microphone. Specific user-programmable capabilities make the GT1524 suitable for many applications including distance learning, boardrooms, conference rooms, courtrooms, and telemedicine.

Product Description

The GT1524 performs a variety of complex, integrated audio functions, all implemented using digital signal processors (DSPs). Adjustments in level and all other functions can be made in one of three ways: front panel programming, activation through a closure on the rear panel, or RS232 serial interface. An integrated telephone interface provides the GT1524's audioconferencing capability and can be customized according to your needs.

The telephone interface can be set to automatically answer, and automatically disconnect on loop drop or call progress tones. Finally, as part of its self-contained audio conferencing design, the GT1524 includes a built-in power amp. The amp delivers 5W of output power into a 4 ohm speaker, eliminating the need to provide external amps for the speakers.

The GT1524 provides local room audio capabilities through the mic/line input, for connecting a mic or mixer; and a line output, for connecting an amplifier. A speaker can also be connected to the speaker terminals. The GT1524 handles distant-site conferencing with a four-wire line-level input/output, which connects to a codec.

The aux input and output terminals allow connection of a VCR or other playback or recording device.

Front Panel

The GT1524 front-panel LCD window and the push-button controls (Figure 2) enable you to view or modify current GT1524 status and settings. The numbered items in Figure 2 correspond to the following descriptions.

For more detail on using the front panel controls, refer to the Installation section.

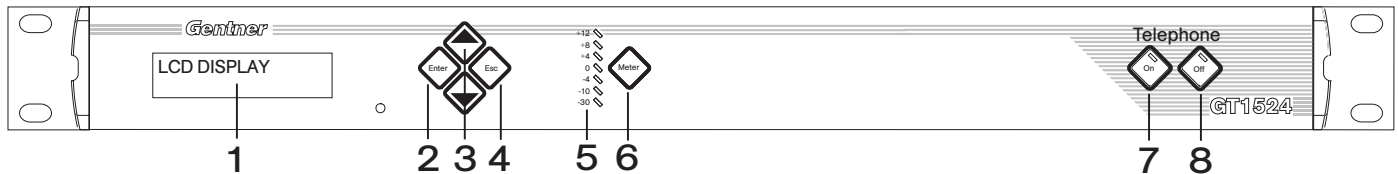

Figure 2. GT1524 Front Panel Controls

1. LCD window: The two-line, 16-character-per-line LCD display is used for the GT1524 setup. Level adjustments are made through a menu system and four front-panel buttons [2, 3, and 4]. Functions that can be accessed through the front-panel LCD include setup, programming, troubleshooting, and numeric audio level and gain readouts.

2. Enter: This button is used to move deeper within a menu, or to edit or store a selected parameter.

3. Up/Down: These buttons scroll up and down through menu options within a specific parameter. These buttons also increase or decrease a numeric value.

4. Esc: This button backs out of a selected parameter without changing its value, or moves the display to the next higher menu level.

5. LED Meter: The LED bar meter displays the audio level of any input or output of the GT1524 as well as the Echo Return Loss (ERL) and Echo Return Loss Enhancement (ERLE) between the Speaker/Line Out and the Mic/Line audio input channel. The LED meter also displays Telco Echo Return Loss (TERL) and Telco Echo Return Loss Enhancement (TERLE) for the telephone hybrid.

6. Meter: This button displays the Meter branch of the GT1524's LCD menu tree from which you can view or enter settings.

7. On: The On switch connects and adapts the GT1524 to the telephone line. Pressing and holding the On button for more than two seconds while the GT1524 is active sends a noise burst to readapt the unit to the phone line. A short tone (1000Hz) is sent out the Speaker and Line outputs to indicate that the GT1524 is connected to the line.

8. Off: The Off switch disconnects the GT1524 from the telephone line and mutes all transmit audio to and from the telephone line. A short tone (400hz) is sent out the Speaker and Line Outputs to notify the user that the GT1524 is disconnected from the line.

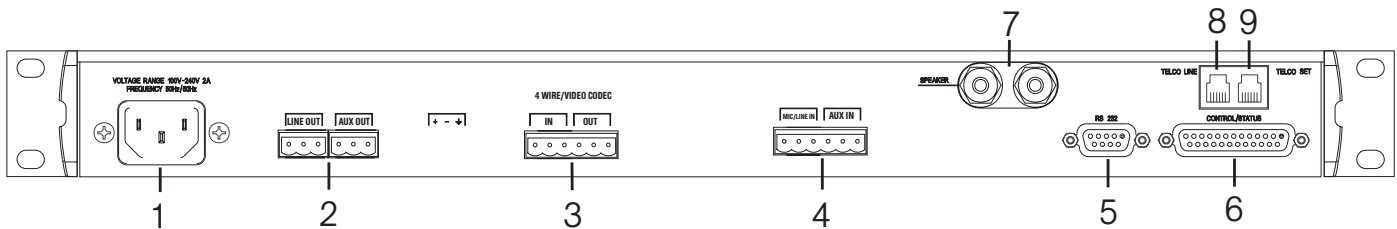

Figure 3. GT1524 Back Panel Connectors

Back Panel

Power and all auxiliary equipment connects to the GT1524 through connectors on the back panel, as shown in Figure 3.

1. Power. This power module accommodates power ranging from 100–240VAC, 50/60Hz, 30W. No switching is required.

2. Line Out, Aux Out. This bank enables connection of line-level outputs with the three terminal Phoenix™ push-on connectors. The Line Output can be used for connection to an external power amplifier or sound reinforcement system. The Aux Out is used for connection to recording equipment, such as a VCR. The nominal output level is 0dBu.

3. 4 Wire/Video Codec In/Out. Connects four-wire transmission systems, such as a video codec.

4. Mic/Line In, Aux In. The Mic/Line input is for connection of a local microphone or input from a local sound system or mixer. The Aux In allows input from other audio sources, such as a VCR or CD player. Nominal input is 0dBu.

5. RS232. This female DB9 serial port is for interconnection between the GT1524 and a PC or custom remote control. See Appendix C for serial port commands.

6. Control/Status. This female DB25 connector is used to interface parallel control and status to the GT1524. Control pins on this connector are used to perform functions via a momentary closure to ground. Each status pin on this connector show the state of the function handled by the pin. Status pins are open collector outputs. When active, the output is pulled to ground; otherwise, the output is an open circuit. See Table 2 in Appendix B for control/status port pinout information.

7. Speaker. One 5W, 4-16 ohm speaker can be directly connected to the GT1524, eliminating the need for a power amplifier.

8. Telco Line. Connects to your telephone line source.

9. Telco Set. Connects to your telephone handset.

Equipment Placement

The GT1524 is designed for mounting in a 19-inch equipment rack. (Do not block any of the ventilation holes.) With a desktop kit, the GT1524 can be modified for tabletop placement.

Telephone Line Requirements

The GT1524 Telephone Interface operates on a standard analog telephone line and connects to the telephone system with a standard RJ11C modular jack. If you do not have an RJ11C jack where you want to install the GT1524, call your telephone company for installation.

3 Installation

Before You Install

The GT1524 is designed to work in almost any acoustic environment. However, to maximize your audio quality, we recommend that you prepare your site by taking the following factors into consideration:

Room Planning

Before installing your GT1524, we recommend that you carefully plan your installation to ensure that you achieve the best possible results. Having a basic understanding of room acoustics and conference room design will not only help you install and operate your GT1524, but will also assist you in the installation and operation of other equipment used in your conference.

Acoustics

Conference and broadcasting rooms have unique acoustic environments. Each room has a different acoustic makeup (Figure 4). The acoustic makeup of the room determines how sound travels within the room. Wall fabrics, windows or other hard surfaces, room size, foot traffic, and the audio equipment used are all factors that impact a room's acoustic conditions.

Directly related to the room's acoustic makeup are several problems common to all conferencing and broadcast situations: reverberation, acoustic echo, and ambient noise. The objective is to minimize the impact these conditions have on your audioconference.

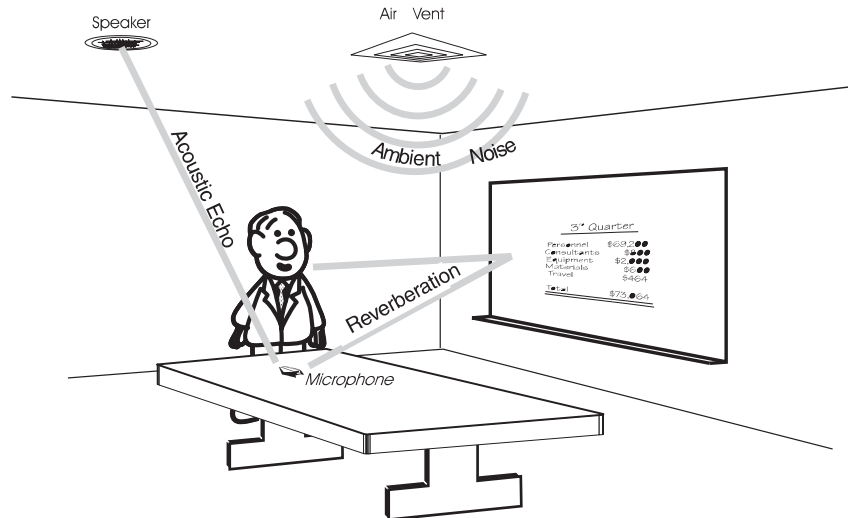

Figure 4. Room Acoustics

Reverberation. Reverberation is the persistence of sound due to repeated reflections from walls, ceiling, floor, furniture, and occupants in a room. Reverberation dissipates over a fixed period of time determined by the room's environment.

Acoustic Echo. Acoustic echo is the sudden return of sound (rather than a smooth decay) caused primarily by a delay in the network or environment. It occurs before or after a signal leaves a speaker and enters a microphone for the return transmission, being relayed to the originating site later. In other words, listeners at the remote location hear their own voices echoed back to them through the speakers and microphones at the opposite location.

Ambient Noise. Ambient noise, also known as room noise, is unwanted background noise picked up by the conference room microphones. Air conditioning, heating fans, and noises created outside the room but still audible inside the room are all examples of ambient noise.

Acoustic Room Treatment

Conference room treatment is recommended to improve audio quality. Rooms that have large areas of windows, white boards, hard floors, etc. are acoustically "live." These areas increase the amount of audio reverberation.

You can improve room acoustics by installing acoustic panels, drapes, and other wall fabrics. Another way to improve overall room acoustics is to keep ambient noise to a minimum.

Microphone Selection

The type of microphone you select can have a dramatic impact on the audio quality of your conference. In particular, the type of microphone used affects the voice pick-up pattern, audio level, and amount of noise introduced into the entire system. Typically, a unidirectional microphone with a cardioid pattern is the preferred choice for teleconferencing applications. Its design allows for maximum pickup from the front of the microphone and minimum pickup from the rear. Cardioid microphones are available in several styles, including tabletop, podium and lavalier.

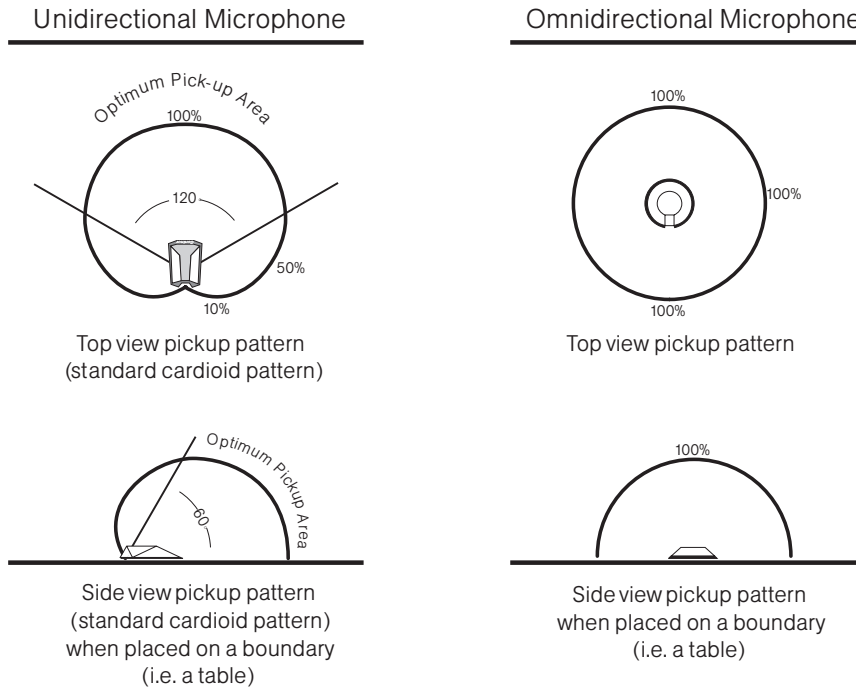

Figure 5. Microphone Isolation

Tabletop

Tabletop (boundary) microphones are designed for large, flat surfaces other than the ceiling. They are most commonly placed on the center of the table, facing outward.

Podium

Podium (gooseneck) microphones are typically used in a lectern application. They are gaining acceptance in some ceiling-type applications and are sometimes used on conference room tables.

Lavalier

Lavalier microphones are used when speaker mobility is a major concern. They are inconspicuous and can be adapted to a wireless configuration.

Microphone Placement

One of the most effective ways to minimize the problems encountered with audioconferencing is to position the speakers and microphones so that you achieve the maximum amount of acoustic isolation (isolation between loudspeaker audio and microphone audio). This can be accomplished using unidirectional microphones and placing the loudspeaker out of the optimum pickup area (Figure 5).

Conference Room Layout

Figure 6 (below) illustrates a basic audioconferencing installation using the GT1524. The GT1524 cancels echo and directs the audio to a video codec and the telephone line. Audio from the video codec and the telephone line is routed to the GT1524 and sent to the speaker(s). A standard telephone set is used to place calls to the remote conference room.

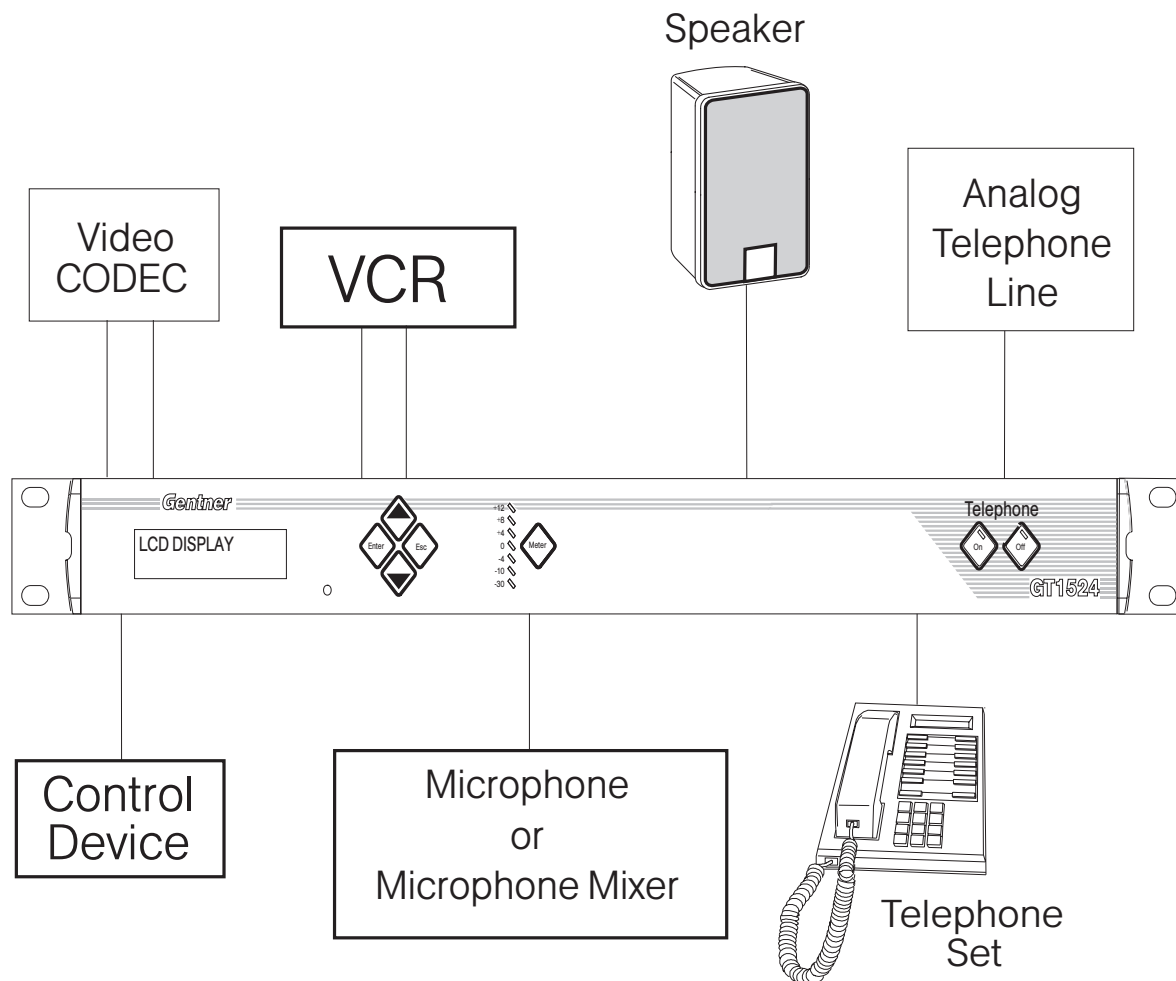

Figure 6. Conference Room Setup

Equipment Interconnections

The following section provides step-by-step instructions for installing your GT1524 system. Figure 7 (below) shows the back panel connections of a fully-installed GT1524 system.

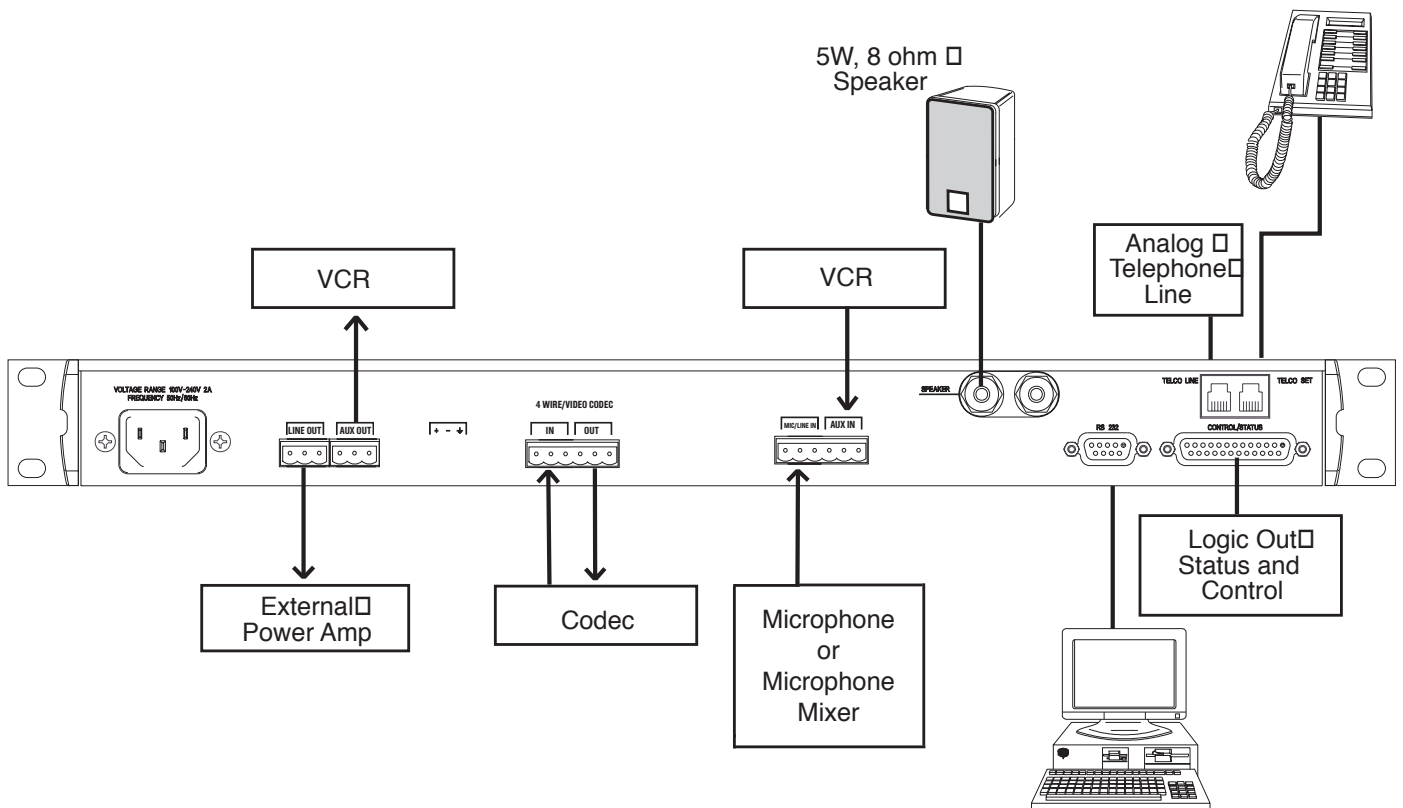

Figure 7. Sample GT1524 Installation

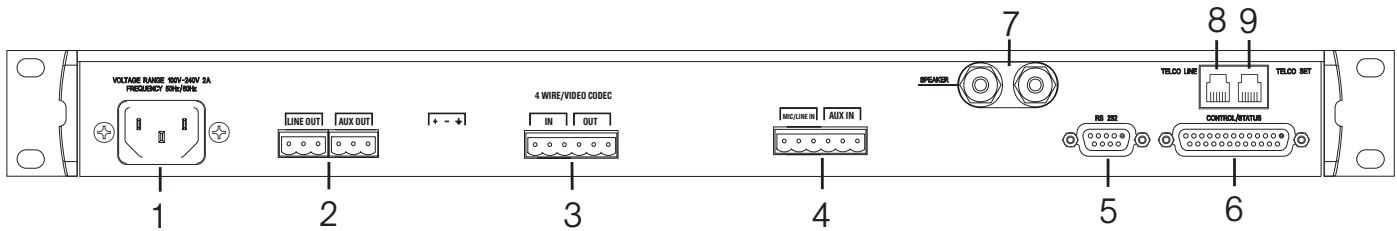
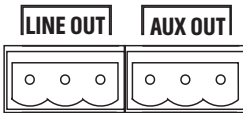
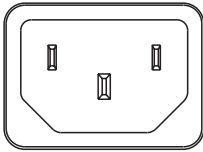
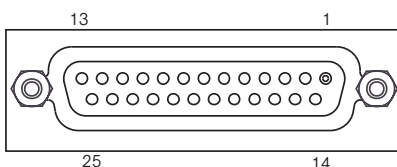
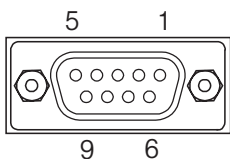
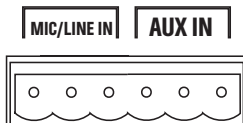
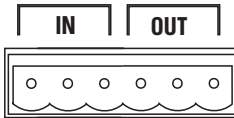

Figure 8. Back Panel Connections



4 WIRE/VIDEO CODEC



Step 1 • Complete Back Panel Connections

You should connect the power cord **last**. Otherwise, the order in which you connect the cables is not important. The connections are discussed in the order they are numbered in Figure 8, above. Individual connectors are also shown in the margin.

1. Power. Connect the power cable after making all other connections. As soon as power is supplied to the unit, the GT1524 initializes and all front-panel LEDs and the LCD light. The power module accommodates 100–240Vac, 50/60Hz, 22-30W.

2. Line Out, Aux Out. Connect an external amplifier or sound reinforcement system to Line Out. Use Aux Out to connect recording equipment, such as a VCR. Nominal output is 0dBu.

3. 4 Wire Video Codec In/Out. Connect a 4-wire transmission system, such as a video codec. Nominal input/output is 0dBu.

4. Mic/Line In, Aux In. Connect a local microphone or input from a local sound system or mixer to Mic/Line In. Aux In allows you to connect an input from another audio source such as a VCR or CD player. Nominal input is 0dBu.

5. RS232. Connect the GT1524 to a PC or custom remote control with this female DB9 serial port.

6. Control/Status. This female DB25 connector is used to interface parallel control and status to the GT1524. Each status pin on this connector show the state of the function handled by the pin. Status pins are open collector outputs. When active, the output is pulled to ground; otherwise, the output is an open circuit. See Table 2 in Appendix B for control/status port pinout information.

7. Speaker. Connect a 5W, 4-16 ohm speaker.

8. Telco Line. Connect your telephone line source.

9. Telco Set. Connect a telephone handset.

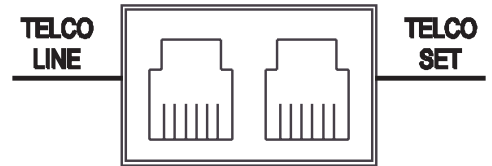
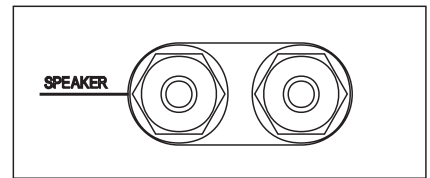

LCD Programming



Figure 9. Front Panel Buttons

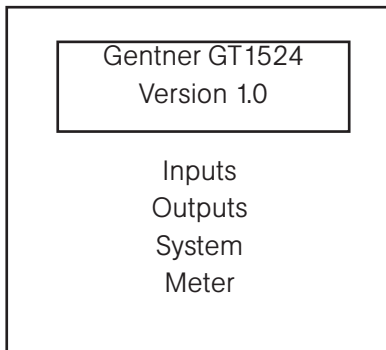

Figure 10: Main Menu Trees



ESC BUTTON NOTE:
Pressing ESC at the top of the tree has no effect.

For most installations, the default settings in the GT1524 do not need to be changed; the system can be used as soon as power is applied. However, if you need to customize any settings, such as telephone connection options or input parameters, you can do so through the front panel user interface.

The front panel includes a 2x16 character LCD, menu buttons, and LED bar meter.

When power is applied to the GT1524, all LEDs light and the LCD panel reads INITIALIZING. If initialization is completed without errors, a title screen appears, showing the product name (top line) and the version number (bottom line). The title screen remains on display until you initiate some action that writes information to the LCD panel or the GT1524 detects and displays an error. If an error is displayed, contact Gentner Technical Support.

Menu Trees

Four main menu trees (menu categories) comprise all of the GT1524 options you can control through the front panel: Inputs, Outputs, System, and Meters (see Figure 10). Enter each of the trees by pressing the up/down buttons and scrolling to the appropriate menu. Then press ENTER. The Meter button will also access the Meter tree directly. The menu trees are structured in levels, such that the first level (top of the tree) branches into multiple subcategories (see Figure 11). These branches typically end when an adjustable parameter or viewable value is reached.

Moving Among the Menu Items

Use the up and down buttons to scroll through the menu items at a particular level. When you reach the last menu item, the display scrolls back to the beginning of the list, and vice-versa.

To descend a menu level (go deeper into the tree), press ENTER. To ascend a menu level (go back toward the top of the tree), press ESC.

Adjusting a Value

To adjust a parameter, first verify that it is flashing. If the parameter is not flashing, it cannot be adjusted until you press ENTER. If the parameter is flashing, adjust the value with the Up and Down buttons. As the value is adjusted, the parameter is updated immediately. For example, if you adjust input gain, you should be able to hear the difference as it changes. To store the new value, press ENTER. To discard the change and revert back to the old value, press ESC. In general, while adjusting parameters, numerical values do not wrap around when the end is reached. However, parameters that toggle between two values (or are a list of values) will wrap around. When adjusting a parameter and an Up or Down button is held for more than two seconds, the parameter will scroll through its values at a faster rate.

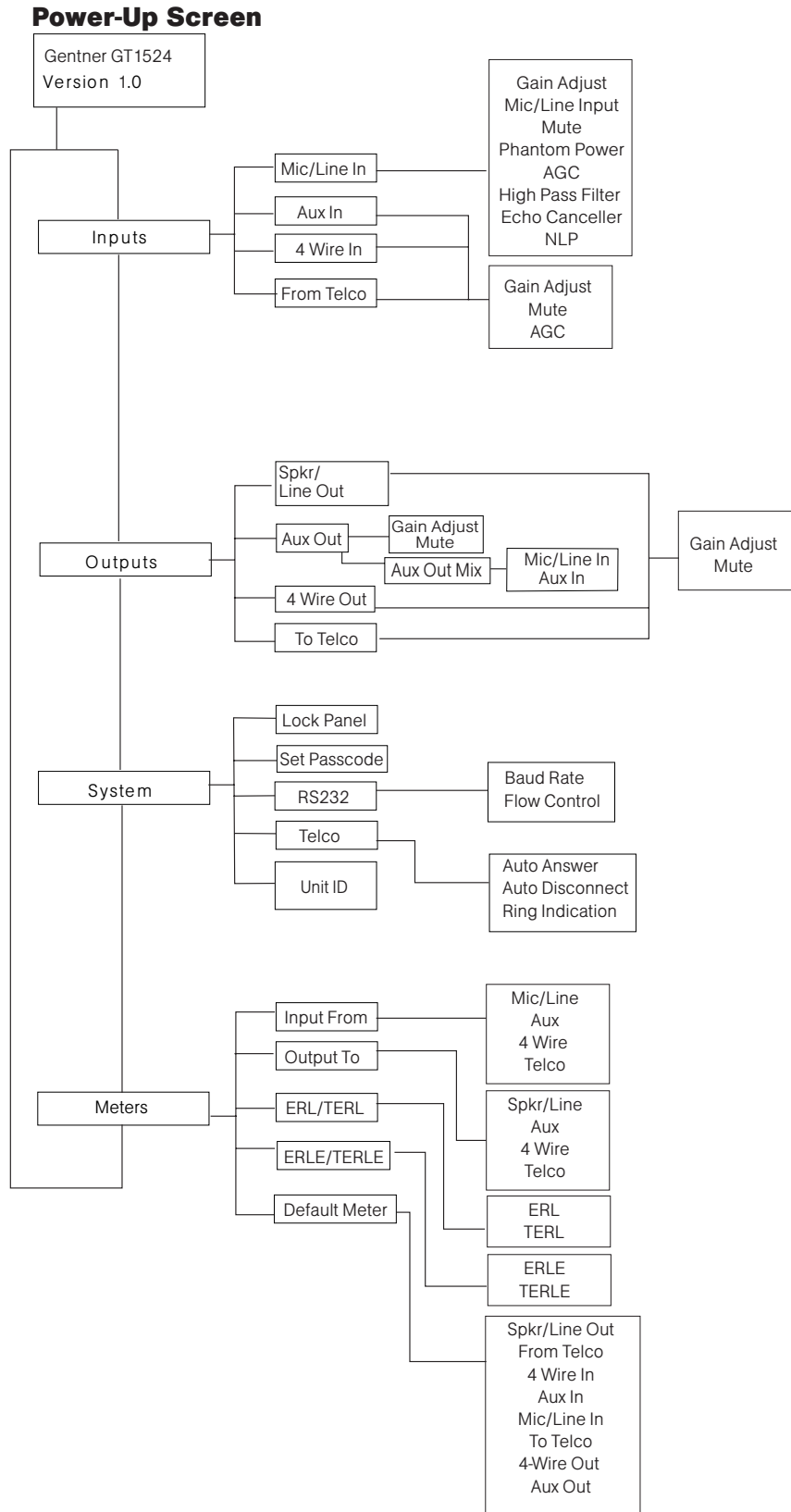

Figure 11. LCD Menu Tree and Defaults

GT1524 Parameters Worksheet					
System-Wide Parameters					
Program Parameter	Selection Range				
Lock Panel	On, Off				
Set Passcode	Any 5 Front Panel Keys (Enter)				
RS232 Baud Rate	9.6 , 19.2, 38.4 kbps				
RS232 Flow Control	On, Off				
Telco Auto Answer	On, Off				
Telco Auto Disconnect	Off, Loop Drop , Call Prog, LD + CP				
Telco Ring Indication	Off, 1, 2, 3, 4				
Unit ID No.	Factory Programmed				
*Timeout	0 - 15 (10)				
*Telco Adapt Mode	Auto , Burst				
*Hook Duration	50 ms, 500 ms				
*Receive Reduction	On, Off				
Meter					
Program Parameter	Selection Range				
Default Meter	Any Input/Output (Spkr/Line Out)				
Input Channel		Mic/Line In	Aux In	4 Wire In	From Telco
Program Parameter	Selection Range				
Gain Adjust	-20dB to 20dB (0)				
Mic/Line Input	Mic 55dB, Mic 25 dB, Line				
Mute	On, Off				
Phantom Power	On, Off				
AGC	On, Off				
High-Pass Filter	On, Off				
Echo Cancellation	On , Off				
NLP Adjust	Off, Soft , Medium, Aggressive				
Output Channel		Spkr/Line Out	Aux Out	4 Wire Out	To Telco
Program Parameter	Selection Range				
Gain Adjust	-20dB to 20dB (0)				
Mute	On, Off				
Aux Out Mix (Mic/Line In)	On , Off				
Aux Out Mix (Aux In)	On, Off				

* at least one of each must

Figure 12. Parameters Worksheet

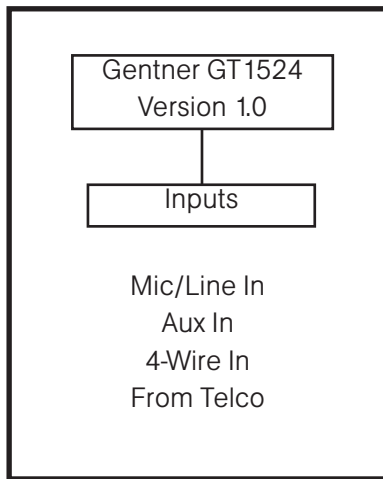

Figure 13. Input-level LCD Parameters

Input Parameters

There are four main submenus under the Inputs menu tree: Mic/Line In, Aux In, 4 Wire In, and From Telco (see Figure 13).

Mic/Line In

Gain Adjust. This adjusts the Mic/Line In submenus, including the level for the Input's gain (ranging between -20dB and 20dB). The default setting is 0dB.

Mic/Line Input. This input defaults as a line-level input (0dB gain) but can be switched to a mic level input (55dB or 25dB gain).

Mute. This parameter mutes the input channel.

Phantom Power. Defaults with 24V phantom power disabled, but may be switched on to accommodate input devices requiring phantom power.

AGC. The input can use automatic gain control (AGC). This feature keeps softer and louder talkers at a consistent transmit level. This feature is disabled when shipped from the factory. The target gain is 0dB and adjusts at 2dB per second. The AGC start adjustment is -20dB, but will adjust only +6dB. Adjustments will not be made at .5dB on either side of the target (0dB).

High-Pass Filter. A high-pass filter may be selected on the Mic/Line input to reduce unwanted noise. The filter has a break frequency at 250Hz, and -3dB down at 200Hz, then rolls off at 6dB per octave. This feature is disabled when shipped from the factory.

Echo Canceller. Activate or deactivate the echo cancellation feature for this input. Factory default is ON.

NLP Adjust. Non-linear processing (NLP) has four settings: soft (6dB), medium (12dB), aggressive (18dB), and OFF. NLP adds more echo cancelling "horsepower" in difficult acoustical environments. Use care when increasing NLP, because of the corresponding trade-offs which can include suppression and half-duplex operation. Factory default is SOFT.

From Telco and 4-Wire In

Three input parameters can be applied to the inputs: Gain Adjust, Mute, and AGC.

Gain Adjust. This adjusts each input's gain (ranging between -20dB and 20dB) in conjunction with the LCD readout and the LED bar graph. The default setting is 0dBu.

Mute. This parameter mutes the input channel.

AGC. The input can use automatic gain control (AGC). This feature keeps softer and louder talkers at a consistent transmit level. This feature is disabled when shipped from the factory. The target gain is 0dB and adjusts at 2dB per second. The AGC start adjustment is -20dB, but will adjust only +6dB. Adjustments will not be made at .5dB on either side of the target (0dB).

Output Parameters

There are four main submenu under the Outputs menu tree: Speaker/Line Out, Aux Out, 4 Wire Out, and To Telco. Each of these submenus contain the same menus at the next menu depth: Gain Adjust and Mute. Aux Out also features an Aux Out Mix parameter, described below. Each parameter is applied to the respective outputs.

Gain Adjust. This adjusts each output's gain (ranging between -20dB and 20dB), in conjunction with the LCD readout and the LED bar meter. Default is 0dB.

Mute. This parameter mutes a particular output channel. Default is OFF.

Aux Out Mix. This parameter selects Mic/Line In and/or Aux In to Aux Out.

System Parameters

The System menu allows you to view five parameters: Lock Panel, Set Passcode, RS232, Telco, and Unit ID. The first four may also be adjusted.

Lock Panel

The GT1524 can be secured from unauthorized adjustments by locking the front panel and establishing a user passcode. Menu items can still be viewed when the panel is locked, but settings cannot be altered or entered until the panel is unlocked by entering the appropriate passcode.

To lock the front panel:

1. Enter the SYSTEM menu
2. Scroll through the menu items to select LOCK PANEL, and press ENTER.
3. Select ON, and press ENTER again.

To unlock the front panel:

1. Attempt to adjust a parameter. The GT1524 prompts you for the passcode.
2. Begin entering the passcode. Once you have correctly entered the

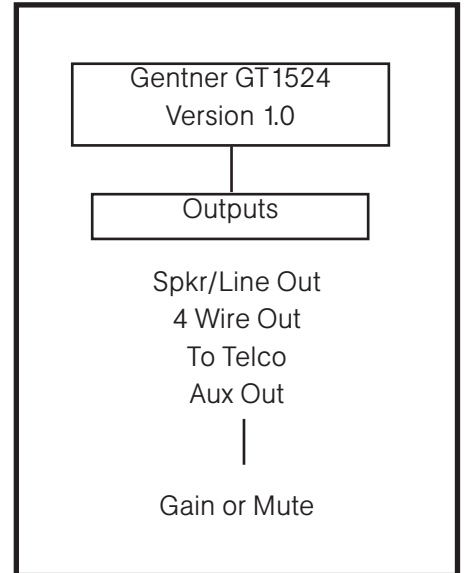

Figure 14. Output-level Parameters

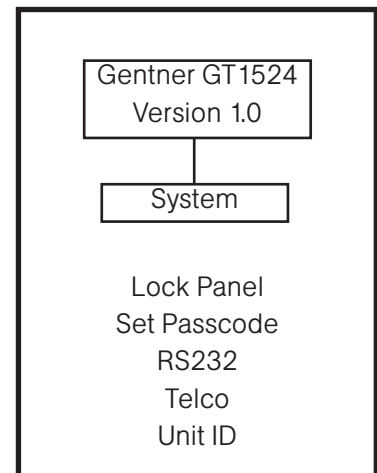

Figure 15. System-level LCD Parameters



LOCK PANEL NOTE:

If you enter a passcode and unlock the system, you must lock it again after making any changes. Otherwise the panel will remain unlocked and accessible to anyone.

fifth character, the front panel unlocks. (The default passcode for all units is Up, Up, Down, Down, ENTER.)

Set Passcode

Once you have unlocked the GT1524, you can change the passcode. Before the GT1524 allows passcode changes, the new passcode must be entered, then re-entered to validate it. The passcode must be five front panel buttons (in any combination or multiple).

RS232

Two RS232 parameters can be adjusted through the front panel LCD: baud rate and flow control. If data is lost during serial access through the RS232 port, a serial overrun error will occur. This is indicated on the LCD display. This parameter sets the GT1524's RS232 port communication rate at 9,600 (default), 19,200, or 38,400 baud (bps).

Baud

To set the baud rate, scroll through the settings to select the desired baud rate, then press ENTER.

Flow Control

The flow control parameter allows activation and deactivation of hardware flow control. The two options are ON and OFF (default). To activate the flow control, scroll to ON and press ENTER. To deactivate it, scroll to OFF and press ENTER.

Telco

Auto Answer On/Off

This parameter sets the telephone interface to automatically answer an incoming call (**AUTO ANSWER ON**), or allow the call to be handled manually (**AUTO ANSWER OFF**).

Auto Disconnect

The interface can also be set to disconnect upon **LOOP DROP, CALL PROGRESS, LOOP DROP + CP** (call progress), or to disconnect manually (**AUTO DISCONNECT OFF**). An audible ring indicator, sent to the PA output, can also be enabled or disabled under this menu.

Unit ID Number

The UNIT ID # allows you to view the read-only unit address set at the factory. This unique ID number identifies that particular unit and cannot be changed.

Meter Parameters

There are five main submenus under the meter menu tree: Inputs, Outputs, ERL/TERL, ERLE/TERLE, and Default Meter. The first four submenus are all handled in the same way.

Referencing the LCD, press the METER button, then scroll through the options (Inputs, Outputs, ERL/TERL and ERLE/TERLE) to specify which is to be metered by the front-panel LED meter. When the appropriate option is visible, press ENTER to begin monitoring its status on the front panel LCD. All items under this menu can be scrolled through by pressing the UP/DOWN arrows.

The default meter parameter determines what is being displayed on the LED meter when the GT1524 times out.

Timeout. The GT1524 has a system mode called TIMEOUT. This parameter may be adjusted through the RS232 port only using the TOUT command. TIMEOUT controls the delay time (in minutes) before the LCD panel will automatically switch back to the title screen and default meter. The range is 0–15 minutes. Default is 10 minutes; 0 disables this mode.

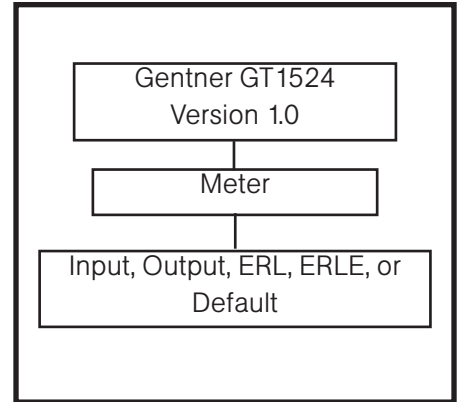

Figure 16. Meter-level Parameters



TIMEOUT NOTE:

Disabling the timeout will allow the GT1524 to remain in the same position in the LCD menu until the LCD menu is manipulated again.

4 Operation

Front Panel

A correctly installed GT1524 virtually runs by itself. Typical operations involve changing volume of an output, muting an input or output, or handling calls on the connected telephone handset. For most installations, a custom remote control (optional) would be used.

Controlling Volume

When participating in a conference, you may find it necessary to increase or decrease the volume of a particular output. For instance, when the audio at a distant location is too soft, adjust the output to the speakers so that the level is comfortable.

To adjust the volume:

1. Determine which output needs to be adjusted.
2. Scroll to the OUTPUTS menu, select the appropriate output, and scroll to GAIN ADJUST. Press ENTER.
3. Adjust the gain level using the Up and Down buttons. You should be able to hear the volume level adjust while increasing or decreasing the gain.
4. Press ENTER when you reach the desired volume level.

The volume adjust procedure is the same for all channels.

Muting

When participating in a conference, you may find it necessary to mute (or un-mute) a particular input or output.

Muting or Unmuting Channel (Input or Output)

1. Determine the input or output you want to mute.



Note: For optimum performance, adjust all inputs to 0dBu before calibrating outputs.



AUTO-ANSWER NOTE:
If **AUTO ANSWER** is turned **ON** under **SYSTEM** settings, the **GT1524** answers the call after the second complete ring. A ringing tone is provided to the Line and Speaker output if Ring Indication is turned on.



NOTE: When using the **DIAL** serial port command, the **GT1524** automatically engages the hybrid. You do not need to press the **ON** button.



AUTO-DISCONNECT NOTE:
If auto-disconnect is turned **ON** in **SYSTEM** settings, the **GT1524** disconnects upon sensing loop drop or call progress tones.

2. Scroll to the desired input or output Press ENTER.
3. Scroll through the input or output parameters until you see MUTE. Press ENTER.
4. Use the UP/DOWN buttons to select ON, then press ENTER. The input or output is now muted. To unmute the input or output, follow the same procedure, but select OFF to deactivate the mute function.

Answering a Call

An incoming call rings on the telephone set connected to the GT1524 (and speaker, if one is connected to the GT1524) and causes the ON LED to flash. There are four ways to answer an incoming call:

1. Set AUTO ANSWER ON to answer the call automatically.
2. Set AUTO ANSWER OFF and press the Telephone/ON button to answer the call manually.
3. Send a serial command (for example, TE 1) through the RS232 port (see GT1524 Serial Commands on page 36).
4. Pick up the telephone handset to answer manually. When you're ready to connect the call to the GT1524, press the Telephone/ON button or send the "TE 1" serial command.

To answer a call on the GT1524, press the ON button on either the front panel or from the RS232 port (TE 1) or just pick up the handset. The green ON LED lights. The red OFF LED turns off.

Making a Call

Call the party using your handset. After the other party has answered, route the call through the GT1524 by pressing the ON button.

The ON LED lights and the GT1524 takes control of the call, disabling the telephone set. You may now safely hang up the handset without disconnecting the call or access the DTMF dialer in the GT1524 via a remote control system.

Disconnecting a Call

If the call is routed through the GT1524 (the ON LED glows green), press the OFF button on the front panel or send a command through the RS232 port (TE 0). The OFF LED glows red, and the ON LED turns off.

Custom Controller Options

The GT1524 is designed to function with remote control systems. The controller is connected to the GT1524 through the RS232 port. The AP IR Remote also functions with the GT1524.

You can perform all actions through the custom controller:

- Turn GT1524 telephone connection on or off

- Mute transmitted and received audio
- Generate DTMF tones
- Adjust volume on received audio
- Re-null the telephone hybrid
- Meter input and output
- Read TERL and TERLE
- Control any function on the unit



REMOTE CONTROL NOTE:
Gentner Communications recommends use of a custom remote controller for user interface. Refer to the manufacturer's documentation for your particular custom remote controller.

Appendices

Appendix A: Specifications

DIMENSIONS:

(L x W x H) 17" x 1.75" x 8"
43.2cm x 4.5cm x 25.4cm

WEIGHT:

7 lbs./3.18 kg dry 12 lbs./5.4 kg

OPERATING TEMPERATURE:

0-50 C, 32-122 F

ECHO CANCELLATION TAIL TIME:

>120 milliseconds

CONNECTORS

POWER:

Auto-adjusting power module; 100-240VAC; 22-30W; 50/60Hz

LINE OUT:

Removable Phoenix[®] block connector, 0dBu nominal, adjustable, balanced bridging

Impedance: 50 Ohms (designed to drive >600 ohm inputs)

Frequency Response: 20Hz to 15kHz \pm 2dB

SNR: >85dB*

THD: <.01%*

AUX OUT:

Removable Phoenix[®] block connector, 0dBu nominal, adjustable, balanced bridging

Impedance: 50 Ohms (designed to drive >600 ohm inputs)

Frequency Response: 20Hz to 15kHz \pm 2dB

SNR: >85dB*

THD: <.01%*

4-WIRE/VIDEO CODEC IN:

Removable Phoenix[®] block connector, 0dBu nominal, adjustable, balanced bridging

Impedance: 20kOhms

Frequency Response: 20Hz to 15kHz \pm 2dB

SNR: >85dB*

THD: <.01%*

4-WIRE/VIDEO CODEC OUT:

Removable Phoenix[®] block connector, 0dBu nominal, adjustable, balanced bridging

Impedance: 50 Ohms (designed to drive >600 ohm inputs)

Frequency Response: 20Hz to 15kHz \pm 2dB

SNR: >85dB*

THD: <.01%*

MIC/LINE IN:

Removable Phoenix[®] block connector, -55 or 0dBu nominal, adjustable, balanced bridging

Impedance: 4kOhms

Frequency Response: 20Hz to 15kHz \pm 2dB

Phantom Power: 24VDC input, selectable

Noise: EIN 20Hz to 15kHz - 125dBu

THD: <.03%*

AUX IN:

Removable Phoenix[®] block connector, 0dBu nominal, adjustable, balanced bridging

Impedance: 20kOhms

Frequency Response: 20Hz to 15kHz \pm 2dB

SNR: >85dB*

THD: <.01%*

SPEAKER OUT:

Binding Post 5W max into 4 Ohms

RS232:

DB9 female, 9,600/19,200/38,400 (bps) baud selectable

TELCO LINE:

RJ11 connector—POTS (Plain Old Telephone Service) line or analog extension from PBX

TELCO SET:

RJ11 connector—analog telephone set

CONTROL/STATUS:

DB25 female; (2) +5VDC pins, 100mA each (8) open collector status outputs, 20V max, 40mA each (8) momentary control inputs, active low

TELCO AUDIO PERFORMANCE

Frequency Response: \pm 2dB from 250Hz to 3.3kHz (AGC disabled)

SNR: >60dB (referenced at -15dBm on/off the telephone line)

THD: <2%, 250Hz to 3.3kHz (ACG disabled) referenced at -15dBm on/off the phone line

Pre Emphasis: +4dB at 2kHz

Telco Cancellation Tail Time:

31 milliseconds

* All measurements are referenced to maximum output level with a bandpass of 20Hz to 20kHz unless otherwise specified.

Appendix B: Connector Pinouts

Table 1. RS232 COM DCE Port Pinout

Pin Number Control

1 DCD	6 DSR
2 TXD	7 CTS
3 RXD	8 RTS
4 DTR	9 No connection
5 Ground	

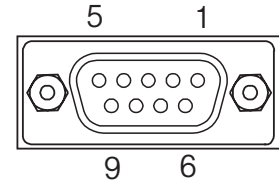
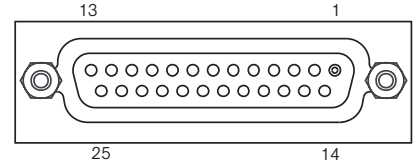

Table 2. Control/Status Port Pinout

Pin Number Default Description

1	Aux In to Aux Out Toggle
2	Status of Aux into Aux Out
3	Mute Mic/Line In Toggle
4	Status of Mic/Line In Mute
5	Telephone On/Off Toggle
6	Telephone On/Off Toggle
7	Auto Answer Toggle
8	Status of Auto Answer
9	Mute Line Out Toggle
10	Status of Line Out Mute
11	Mute 4-wire In Toggle
12	Status of 4-wire In Mute
13	Volume Up Speaker/Line (1dB)
14	no connection
15	Volume Down Speaker Line (1dB)
16	no connection
17	no connection
18	no connection
19	no connection
20	no connection
21	Ring Indication
22	no connection
23	+5Vdc
24	+5Vdc
25	Ground



NOTE: All commands are momentary.

Appendix C: Serial Port Commands



The first 16 pins of the Control/Status port are programmable through direct serial port commands.

Serial Port Commands

The GT1524 accepts serial commands through the serial port. The commands provide the same control as the LCD menu structure, plus some additional controls. The following commands pertain only to the GT1524. RS232 Serial Port Protocol is 9,600 (default), 19,200 or 38,400 baud, 8bits, 1 stop bit, no parity. Refer to the Serial Port Commands table (Figure 17) for the GT1524's serial commands.

The structure of serial commands is as follows:

Command, then any additional options in the order that they appear in the command descriptions on the following pages. Commands can be either UPPER CASE or lower case. Return values are always in upper case. For a command to be recognized by the serial port, the command must be terminated by a carriage return.

Command Syntax

The serial command line uses the following typographic conventions:
<X> Parameters enclosed in "<>" indicate a mandatory parameter
[X] Parameters enclosed in "[]" indicate an optional parameter
1-8 Parameters separated by a "-" indicate a range between the values
4, 7, 9 Parameters separated by a "," indicate a list of available values
MREF Words in ALL CAPS bold indicate command text

Error Codes

The following lists possible error messages and their explanations:

- ERROR 1 (Future)
- ERROR 2 Could not extract a command from the string received
- ERROR 3 Serial overrun
- ERROR 4 Reserved
- ERROR 5 Invalid parameter
- ERROR 6 Unrecognized command

The command string will then be explained (where necessary), followed by the returned values and (where necessary) an example.

GT1524 Serial Commands	
Command	Function
AA	Selects/Reports Auto Answer for Telco Port
AD	Selects/Reports Auto Disconnect for Telco Port
AGC	Enables/Disables AGC†
AUXMIX	Enables/Disables Mic/Line In and Aux In to Aux Out
BAUD	Sets/Reports RS232 Port Baud Rate
DFLTM	Sets/Reports Default Meter
DIAL	Sends Dial String to Telco Port
EC	Enables/Disables Echo Cancellor
ERL	Returns ERL for the Mic/Line In Channel
ERLE	Returns ERLE for the Mic/Line In Channel
FLOW	Enables/Disables Flow Control
FPP	Sets/Reports Front Panel Passcode
GAIN	Sets/Reports Gain Setting†
HOOK	Sends Hook/Flash Command
HOOKD	Selects/Reports Hook Duration Time
LFP	Enables/Disables Front Panel Lock
LVL	Reports Level†
MHP	Sets/Reports High Pass Filter Status
MLINE	Sets/Reports Mic Gain
MUTE	Sets/Reports Mute†
NLP	Sets/Reports Non-Linear Mic Processing
NULL	Sends Noise Burst, Adapting Unit to Phone Line
PP	Sets/Reports Phantom Power for Mic/Line In
RING	Reports Presence of a Ring on Telco Port
RINGEN	Selects/Reports Ring Indication
RXRD	Sets/Reports Receive Reduction to Telco Port
TAMODE	Sets/Reports Telco Adapt Mode
TE	Sets/Reports Telco Off Hook Status
TERL	Returns Echo Return Loss for Telco Channel
TERLE	Returns Echo Return Loss Enhancement for Telco Channel
TOUT	Sets/Reports Inactivity Timeout
UID	Returns ID Number of Unit
VER	Returns Current Version of Software

†Applied to a specific channel

Figure 17. Serial Commands

Serial Command Parameters and Explanations

AA

This command activates and deactivates the auto answer feature.

AA <X>

Explanation

<X>

X=0 Parameter disables auto-answer

X=1 Parameter enables auto-answer

X=2 Parameter to toggle the state from one state to the other (regardless of current state)

X= Null Parameter to report back the current state

Return Values

The command will return the updated condition (On=1, Off=0) of the auto answer in the same format as the command.

AD

This command changes the state of the auto disconnect function.

AD <X>

Explanation

<X>

X=0 Parameter to set Auto Disconnect to OFF

X=1 Parameter to set Auto Disconnect to LOOP

X=2 Parameter to set Auto Disconnect to Call Progress (CP)

X=3 Parameter to set Auto Disconnect to LOOP+CP

X=Null Parameter to report back the current state

Return Values

The command will return the updated connection state of the unit in the same format as the command. If the sent command changes the state of the unit, the updated state is returned.

If:	Command Returns:
current disconnect state is OFF	AD 0
current disconnect state is LOOP	AD 1
current disconnect state is CP	AD 2
current disconnect state is LOOP+CP	AD 3

AGC

This command changes or reports back the state of the AGC for a microphone or line input.

AGC <CH> <X>

Explanation

<CH>

CH= 1 Mic./Line input

CH= 2 Aux. input

CH= 3 4wire input

Ch=4 telco input

<X>

X=0 Parameter to set the state to OFF
X=1 Parameter to set the state to ON
X=2 Parameter to toggle the state from one state to the other
(regardless of current state)
X= Null Parameter to return the current state

Return Values

The command will return the updated condition (On=1, Off=0) of the AGC in the same format as the command.

AUXMIX

This command changes or reports back the state of the Aux Mix Out.
AUXMIX <CH> <X>

Explanation

<CH>
CH=1 Mic/Line In
CH=2 Aux In
<X>
X=0 Parameter to set the state to OFF
X=1 Parameter to set the state to ON

Return Values

The command will return the updated condition of the Aux Mix in the same format as the command.

BAUD

This command selects or returns the baud rate for the RS232 port on the GT1524.
BAUD <X>

Explanation

<X>
X=1 Selects 9,600 baud (bps) rate
X=2 Selects 19,200 baud (bps) rate
X=3 Selects 38,400 baud (bps) rate
X= Null Parameter to return the baud (bps) rate

Return Values

The command will return the updated condition (1=9,600 baud, 2=19,200 baud, 3=38,400 baud) of the RS232 baud rate in the same format as the command.

DFLTM

This command changes and reports back the status of the default meter.
DFLTM <CH> <W>

Explanation

<CH>
CH= 1 Mic./Line input, Line output
CH= 2 Aux. input, Aux output
CH= 3 4 wire input, 4 wire output

Ch=4 telco input, telco output

<W>

W= I Parameter to specify an input channel

W= O Parameter to specify an output channel

Return Values

The command will return the current default meter in the same format as the command.

DIAL

This command generates DTMF tones. This capability remains active after the call is placed so tones can be issued for use with voice mail and pagers.

DIAL <STRING>

Explanation

<STRING> is any valid combination of touch tone characters. A comma indicates a two-second pause. STRING has a maximum length of 15 characters. Valid characters are 0 through 9, A through D, *, # and ",."

Return Values

DIAL returns the dialed string of numbers. For example, the following command dials the number 801-975-7200. A "9" and a pause are generated to get an outside line on a PBX:

The number to be dialed: The following is returned out the serial port:

DIAL 9,8019757200 DIAL 9,8019757200

EC

This command changes or reports back the state of the echo canceller.

EC <X>

Explanation

<X>

X=0 Parameter to set the state to OFF

X=1 Parameter to set the state to ON

X=NULL Parameter to return the current state

Return Values

The command will return the updated condition (On=1, Off=0) of the echo canceller in the same format as the command.

ERL

This command reports back the echo return loss (ERL) in dB.

ERL

Return Values

The command will return the ERL in the same format as the command (ERL 20).

ERLE

This command reports back the echo return loss enhancement (ERLE) in dB.

ERLE

Return Values

The command will return the ERLE in the same format as the command (ERLE 20).

FLOW

This command selects or reports whether hardware flow control is enable or disabled for the GT1524. Hardware flow control is implemented using RTS and CTS.

FLOW <X>

Explanation

<X>

X=0 Sets flow control to OFF

X=1 Sets flow control to ON

X=NULL Parameter to return the current mode

Return Values

The command will return the updated condition (On=1, Off=0) of the GT1524 in the same format as the command.

FPP

This command sets and reports the current passcode setting for the GT1524.

FPP <X>

Explanation

<X>

X=1 Up button

X=2 ENTER button

X=3 ESC button

X=4 Down button

X=5 METER button

X=NULL Parameter to return current passcode

Return Values

The command returns the current or updated condition of the front panel passcode.

GAIN

This command changes or reports back the gain for a channel. The command supports all inputs and outputs.

GAIN <CH> <W> <X> [<Y>]

Explanation

<CH>

CH= 1 Mic./Line input, Line output

CH= 2 Aux. input, Aux output

CH= 3 4 wire input, 4wire output

Ch=4 telco input, telco output

<W>

W=I Parameter to set input

W=O Parameter to set output

<X>

X= -20 to 20 Parameter to set the level

X= Null Parameter to return the current level

<Y>

Y=R Parameter to indicate relative

Y=A Parameter to set the level absolute

Y=Null Parameter will default to R (relative)

Return Values

The command will return the updated level of the channel in the same format as the command. The level returned is always absolute.

Examples

The following command lowers the gain 3dB on the Mic/Line input channel.

GAIN 1 I -3

HOOK

This command sends a momentary interruption in the line seizure (hook flash) to the telephone line.

HOOK

Return Values

If hook flash succeeded, the following is returned out the port:

HOOK 0

HOOKD

This command controls and reports the Hook Duration of the unit.

HOOKD <X>

Explanation

<X>

X=1 Parameter to set Hook Duration to 50 ms.

X=2 Parameter to set Hook Duration to 500 ms.

X=Null Parameter to report back the current state.

Return Values

The command will return the current hook duration of the unit in the same format as the command. If the sent command changes the hook duration of the unit, the updated hook duration is returned.

LFP

This command locks, unlocks, or returns the current state of the front panel from the serial port.

LFP <X>

Explanation

<X>

X=0 Parameter to unlock the front panel.

X=1 Parameter to lock the front panel

X=2 Parameter to toggle the state from one state to the other (regardless of current state)

X=NULL Parameter to return the current state of the front panel

Return Values

The command will return the updated condition of the front panel.

LVL

This command reports back the level for a given channel.

LVL <CH> <W>

Explanation

<CH>

CH= 1 Mic./Line input, Line output

CH= 2 Aux. input, Aux output

CH= 3 4 wire input, 4wire output

Ch=4 telco input, telco output

W= I Parameter to specify an input meter

W= O Parameter to specify an output meter

Return Values

The command will return the input level of the channel in the same format as the command.

MHP

This command changes or reports back the state of the high pass filter for the Mic/Line input.

MHP <X>

Explanation

<X>

X=0 Parameter to set the state to OFF

X=1 Parameter to set the state to ON

X=NULL Parameter to return the current state

Return Values

The command will return the updated condition (On=1, Off=0) of the high pass filter in the same format as the command.

MLINE

This command changes or reports back how much gain is applied to the Mic/Line input. The three settings are 0dB, 25dB, and 55dB.

MLINE <X>

Explanation

X=1 Parameter to set the state to 55dB gain

X=2 Parameter to set the state to 25dB gain

X=3 Parameter to set the state to 0dB (line level)

X= Null Parameter to return the current state

Return Values

The command will return the updated condition of the gain applied in the same format as the command.

MUTE

This command changes or reports the state of mute for a given channel.

MUTE <CH> <W> <X>

Explanation

<CH>

CH= 1 Mic./Line input, Line output

CH= 2 Aux. input, Aux output

CH= 3 4 wire input, 4wire output

Ch=4 telco input, telco output

<W>

W=I Parameter to set input

W=O Parameter to set output

<X>

X=0 Set mute to OFF

X=1 Set mute to ON (mute the selected channel)

X=2 Parameter to toggle the state from one state to the other (regardless of current state)

X=NULL Report the current state of mute for the selected channel

Return Values

The command will return the mute status (On=1, Off=0) in the same format as the command.

NLP

This command changes or reports back the state of the nonlinear processing for the echo canceller.

NLP > <X>

Explanation

X=0 Parameter to set the state to OFF

X=1 Parameter to set the state to soft

X=2 Parameter to set the state to medium

X=3 Parameter to set the state to aggressive

X= Null Parameter to return the current state

Return Values

The command will return the updated condition (0=Off, 1=Soft, 2=Medium, 3=Aggressive) of the nonlinear processing in the same format as the command.

NULL

This command sends a short noise burst down the telephone line and adapts the GT1524 to the telephone line.

NULL

Return Values

NULL is returned out the serial port when the command has been executed.

PP

This command changes or reports back the state of the phantom power for a microphone.

PP <X>

Explanation

<X>

X=0 Parameter to set the state to OFF

X=1 Parameter to set the state to ON

X=Null Parameter to return the current state

Return Values

The command will return the updated condition (On=1, Off=0) of the phantom power in the same format as the command.

RING

This command reports the presence of a Ring on the Telco port. (This is an indication only.)

RING

Return Value

The Ring is sent if a valid ring has been sensed on the Telco line:

RING

RINGEN

This command changes or reports back the state of the Ring Indication.

RINGEN <X>

Explanation

<X>

X=0 Parameter to set the state to OFF

X=1 Parameter to set the state to RING 1

X=2 Parameter to set the state to RING 2

X=3 Parameter to set the state to RING 3

X=4 Parameter to set the state to RING 4

X= Null Parameter to return the current state

Return Values

The command will return the updated condition of the Ring Indication in the same format as the command.

RXRD

This command controls or reports the Receive Reduction control of the unit.

RXRD <X>

Explanation

<X>

X=0 Parameter to set Receive Reduction to OFF

X=1 Parameter to set Receive Reduction to ON
 X=2 Parameter to toggle the current state
 X=NULL Parameter to report back the current state

Return Values

The command returns the updated connection state of the unit in the same format as the command.

TAMODE

This command controls or reports the Telephone Adapt Mode control of the unit.

TAMODE <X>

Explanation

<X>

X=0 Parameter to set Telephone Adapt Mode to Auto
 X=1 Parameter to set Telephone Adapt Mode to Burst
 X=NULL Parameter to report back the current state

Return Values

The command returns the updated connection state of the unit in the same format as the command.

TE

This command controls or reports the connection status of the unit.

TE <X>

Explanation

<X>

X=0 Parameter to set the unit to disconnect from the line
 X=1 Parameter to set the unit to connect to the line
 X=2 Parameter to toggle the state from one state to the other
 X=NULL Parameter to report back the current state

Return Value

If the current state is ON, the following is returned. If the current state is OFF, the following is returned out the serial port:

TE 1 TE 0

TERL

This command reports back the telephone echo return loss (TERL) for the GT1524 in decibels.

TERL

Example:

If the current TERL level is 10 dB, the following is returned out the serial port:

TERL 10

TERLE

This command reports back the telephone echo return loss enhancement (TERLE) for the GT1524 in decibels.

TERLE

Example

If the current TERLE level for the telephone canceller is 20dB, the following is returned out the serial port:

TERLE 20

TOUT

This command sets or reports the current inactivity timeout before returning to the title screen used by the unit.

TOUT <X>

Explanation

<X>

X=0 Disables inactivity timeout

X=1-15 Sets the number of minutes specified

X=NULL Parameter to return the current number of minutes

Return Values

The command will return the current timeout value. If the command changed the timeout, the updated timeout is returned.

UID

This command returns the unique ID number, the device type, and the device number of the GT1524. This command is read only. The unique ID number is preprogrammed at the factory and is unique to the unit.

UID

Return Values

UID returns the device type and unique ID number. The unique ID is composed of an eight-digit hex number assigned at the factory to uniquely identify the unit.

Example

The following command requests the unit ID from device: The following is returned out the serial port:

UID UID A4EF906C

VER

This command returns the current version of software. This version is unique to a released version of software and is comprised of the DSP, the FPGA, and HC11 software. This command is read only.

VER

Return Values

VER returns the version of software in the same format as the command. The Version is composed of a major version number followed by a period and a minor version number.

Example:

The following command requests the software version: The following is returned out the serial port:

VER 2.0

Appendix D: Compliance Statements

FCC Part 15 Compliance

This device complies with Part 15 of the FCC rules. Operation is subject to the following two conditions: (1) This device may not cause harmful interference, and (2) this device must accept any interference received, including interference that may cause undesired operation.

FCC Part 68 Compliance

A label containing, among other information, the FCC registration number and Ringer Equivalence Number (REN) for this equipment is prominently posted on the equipment. If requested, this information must be provided to your telephone company.

USOC Jacks: This device uses RJ11C and RJ21X terminal jacks.

The REN is used to determine the quantity of devices which may be connected to the telephone line. Excessive RENs on the telephone line may result in the devices not ringing in response to an incoming call. In most, but not all areas, the sum of the RENs should not exceed five (5). To be certain of the number of devices that may be connected to the line, as determined by the total RENs, contact the telephone company to obtain the maximum RENs for the calling area.

If this equipment causes harm to the telephone network, the telephone company will notify you in advance that temporary discontinuance of service may be required. If advance notice is not practical, the telephone company will notify the customer as soon as possible. Also, you will be advised of your right to file a complaint with the FCC if you believe it is necessary. The telephone company may make changes in its facilities, equipment, operations, or procedures that could affect the operation of the equipment. If this happens, the telephone company will provide advance notice for you to make the necessary modifications in order to maintain uninterrupted service.

If you experience problems with this equipment, call Gentner Communications Corporation at (801) 975-7200 for repair and warranty information. If the trouble is causing harm to the telephone network, the telephone company may request you remove the equipment from the network until the problem is resolved.

Industry Canada Compliance

The Industry of Canada label identifies certified equipment. This certification means that the equipment meets certain telecommunications network protective operational and safety requirements. The Department does not guarantee the equipment will operate to the user's satisfaction.

Before installing this equipment, users should ensure that it is permissible to be connected to the facilities of the local telecommunications company. The equipment must also be installed using an acceptable method of connection. In some cases, the company's inside wiring associated with a single line individual service may be extended by means of a certified connector assembly (telephone extension cord). The customer should be aware that compliance with the above conditions may not prevent degradation of service in some situations.

Repairs to certified equipment should be made by an authorized Canadian maintenance facility designated by Gentner Communications. Any repairs or alterations made by the user to this equipment, or equipment malfunctions, may give the telecommunications company cause to request the user to disconnect the equipment.

Users should ensure for their own protection that the electrical ground connections of the power utility, telephone lines and internal metallic water pipe system, if present, are connected together. This precaution may be particularly important in rural areas.

European Compliance

This equipment has been approved in accordance with Council Decision 98/482/EC for pan-European single terminal connection to the public switched telephone network (PSTN). However, due to differences between the individual PSTNs provided in different countries, the approval does not, of itself, give an unconditional assurance of successful operation on every PSTN network termination point. In the event of problems, you should contact your equipment supplier in the first instance.

Gentner Communications Corporation of 1825 Research Way, Salt Lake City, Utah 84119, U.S.A. declares that this equipment is designed to be compatible with the following networks: Austria, Belgium, Denmark, Finland, France, Germany, Greece, Iceland, Ireland, Italy, Liechtenstein, Luxembourg, The Netherlands, Norway, Portugal, Spain, Sweden, Switzerland, and United Kingdom.

Gentner[®]

Perfect Communication through Technology, Service, and Education.[™]

Gentner Communications Corporation
1825 Research Way, Salt Lake City, UT 84119

Phone: 1.800.945.7730 / +1.801.975.7200

Fax: 1.801.977.0087

Web: www.gentner.com

Manual Part No. 800-114-101