

# VideoLabs® Ceiling DocCam™

Installation Instructions & Operator's Guide

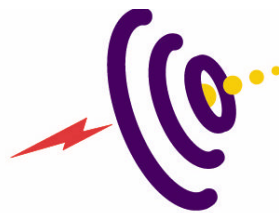
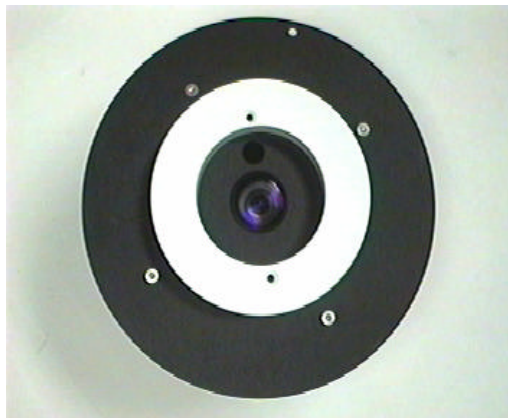

**VIDEOLABS**

# VideoLabs Ceiling DocCam Table of Contents

<b>Intended Use</b>	<b>3</b>
<b>FCC Statement</b>	<b>3</b>
<b>1.0 Unpacking and Getting Started</b>	<b>4</b>
1.1 Contents of Ceiling DocCam Package	4
1.2 First-Time Set Up	4
1.3 Cable Connections	7
1.4 IR Remote Control	9
1.5 RS-232 Remote Control	9
1.6 Care and Cleaning	10
1.7 Operating And Storage Conditions	10
<b>2.0 Troubleshooting</b>	<b>10</b>
<b>3.0 Technical Specifications</b>	<b>11</b>
<b>4.0 Warranty Information</b>	<b>12</b>
<b>5.0 Quick Connect Guide</b>	<b>14</b>
<b>Appendix 1 – RS-232C Control Information</b>	<b>15</b>

## **INTENDED USE**

Before operating the Ceiling DocCam, please read the entire manual thoroughly. The VideoLabs Ceiling DocCam was designed, built and tested for use indoors, and with the provided power supply. The use of a power supply other than the one provided or outdoor operation has not been tested and could damage the camera or peripheral equipment and/or create a potentially unsafe operating condition.

## **IMPORTANT SAFEGUARDS**

1. Read and understand all instructions before using.
2. Do not operate the appliance if the power cord is damaged or if the appliance has been dropped or damaged. A qualified service technician must examine the appliance before operating.
3. Position the cord so that it will not be tripped over, pulled, or in contact with hot surfaces.
4. Always unplug the appliance from the electrical outlet before cleaning or servicing.
5. To reduce the risk of electric shock, do not immerse in water or other liquids.



**Use only the power supply provided with the Ceiling DocCam.  
Use of any unauthorized power supply will void any and all warranties.**

## **SAVE THESE INSTRUCTIONS**

The information contained in this manual will help you install and operate your VideoLabs Ceiling DocCam.

## **FCC STATEMENT - CLASS B:**

This equipment has been tested and found to comply with the limits for a class B digital device, pursuant to Part 15 of the FCC rules. These limits are designed to provide reasonable protection against harmful interference in a residential installation. This equipment generates, uses and can radiate radio frequency energy, and if not installed and used in accordance with the instruction manual may cause interference to radio communications. However, there is no guarantee that interference will not occur in a particular installation. If this equipment does cause interference to radio or television reception, the user is encouraged to correct the interference by one or more of the following measures:

1. Reorient or relocate the receiving antenna.
2. Increase the separation between equipment and receiver.
3. Connect equipment into an outlet on a circuit different from that of the receiver.
4. Consult the dealer or an experienced radio TV technician for help.

## 1) Unpacking and Getting Started

### 1.1 Contents of Ceiling DocCam Package

The following items are included with the Ceiling DocCam (see Figure 1):

1. Camera Module in UL Rated Plenum Enclosure
2. White Ceiling Trim Ring
3. Two Ceiling Tile Support Rails with Aluminum Positioning Clips
4. Wall Plate for Composite Video, S-Video and Power Connections
5. RCA Jack to BNC Plug Adapter
6. IR Remote Control with 2 - AAA Batteries
7. 50 Foot Plenum Rated Category 5 Cable (RJ-45 to RJ-45)
8. 25 Foot S-Video (S-VHS) Cable
9. 12 Volt DC Power Supply

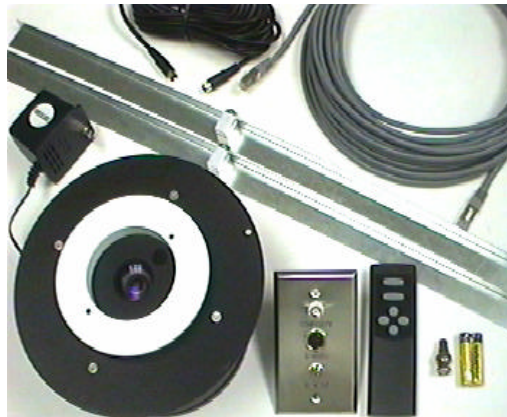

Figure 1

If any of the items are missing, please contact VideoLabs at 1-800-467-7157 or 763-542-0061.

### 1.2 First-Time Set Up of the Ceiling DocCam

The Ceiling DocCam is an integrated document/object camera designed for use within a suspended ceiling. Recommended ceiling heights are between 8 to 11 feet. To locate the Ceiling DocCam above the surface of the table, follow these steps:

1. Start with a string or plumb bob and attach it to the ceiling tile with a thumb tack.
2. Position the string directly over ample table space or work surface and allow for easy access for document and object positioning.

3. Cut a 3-1/2" diameter round hole into the front side of the ceiling tile centered on the string. It is strongly recommended to score the front of the tile with a sharp utility knife prior to cutting the tile. The camera module bezel (front ring) will fit into the 3-1/2" opening from the rear of the tile (see Figure 2).

Figure 2: Side View – Camera Module Enclosure

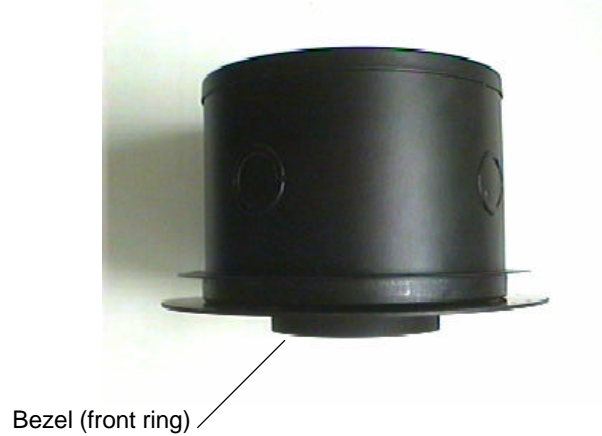

4. Attach the tile support rails with the aluminum positioning clips to support the weight of the camera on the ceiling tile and between the ceiling grid runners. Attach the positioning clips as shown to the tile support rail and to the camera module enclosure fin. Slide the tile support rail through the clip into position (see Figures 3 & 4) and tighten down firmly.

Figure 3: Enclosure with Tile Support Rails Attached



Figure 4: Positioning Clip Attached to Rails



Note: Attach Clip to Rail and Enclosure Fin as Shown

- The tile support rails distribute the weight of the camera into the grid and prevent tile warping. The camera module enclosure and the tile support rails allow for exceptional positioning freedom when used with 2'x2' and 2'x4' ceiling tiles (Figure 5).

Figure 5: Enclosure and Tile Support Braces Positioned on 2'x2' Ceiling Tile

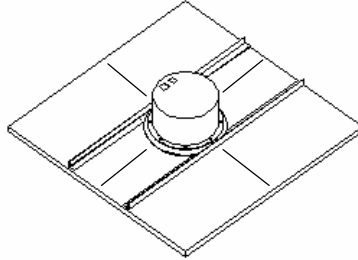

- After the camera module enclosure is positioned above the ceiling, attach the white trim ring to the camera module bezel from the front of the tile and tighten gently. This will pull the bezel and camera module together and firmly hold the camera in position against the ceiling tile. Rotate the camera enclosure module with the positioning indicator pointing toward the monitor or display device. This orientation is standard document camera orientation (see Figures 6 & 7).

Figure 6: Enclosure and Trim Ring

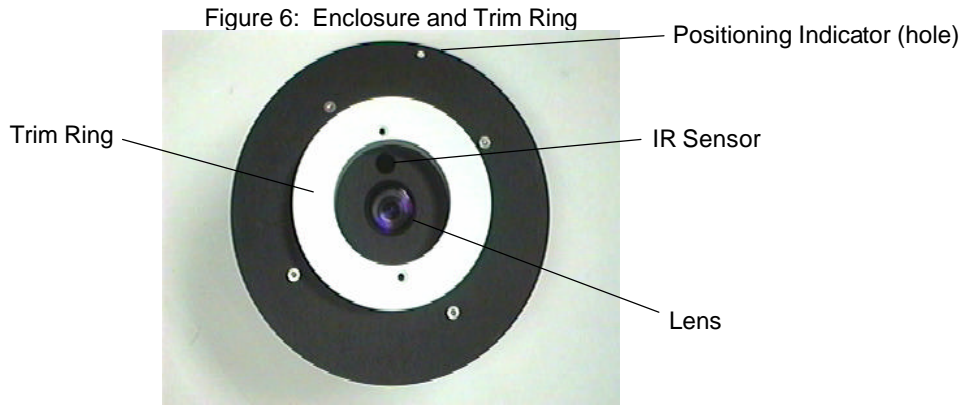
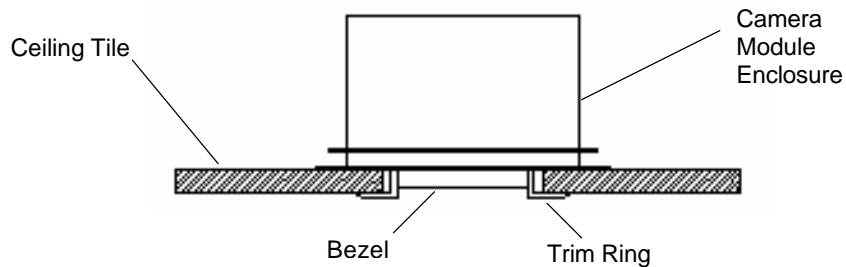

Figure 7: Enclosure and Trim Ring with Ceiling Tile (side view)



### 1.3 Cable Connections

The camera module enclosure and 50' connection cable are plenum rated for use inside plenum return air spaces. The connectors on the back of the camera module enclosure are labeled MAIN and RS-232. The enclosure is also equipped with threaded inserts positioned to enable attachment to a standard electrical box (not provided) and with standard conduit connectors (Figure 8).

Figure 8: Rear of Camera Module Enclosure

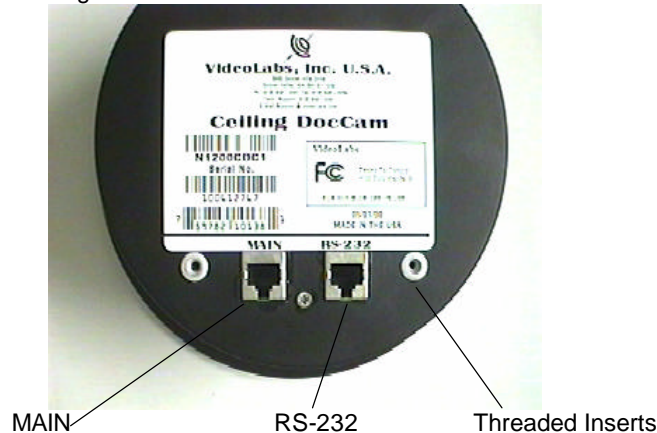

The MAIN connector carries S-video (S-VHS), composite video and power from the rear of the camera module enclosure to the rear of the wall plate with the provided 50' Category 5 plenum rated RJ-45 to RJ-45 cable (Figure 9). The RS-232 connector is provided for use with control systems such as Crestron and AMX (the RS-232 cable is not provided).

Figure 9: Rear of Enclosure and Plate Connected with 50' Cable

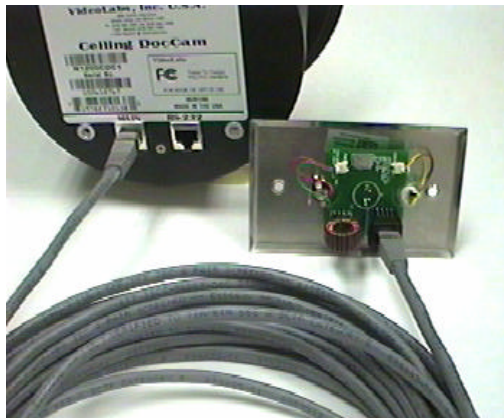

The front of the wall plate provides the break-out connections for power, S-video and composite video. The wall plate may be attached to a standard single gang



wall box or placed in an equipment rack in a surface mount wall box. A 12VDC power supply, 25' S-video cable and a RCA jack to BNC plug adapter are provided for flexibility in connection to video devices (Figures 10, 11 & 12).

Figure 10: Power Supply Attached to Front of Wall Plate



Plug the 12VDC power supply into a standard wall outlet (110V-120V) and the jack labeled 12 V DC.



**Use only the power supply provided with the Ceiling DocCam.  
Use of any unauthorized power supply will void any and all warranties.**

Figure 11: Front of Plate



Composite Video Jack (BNC)

S-Video Jack

Figure 12: Rear of Plate

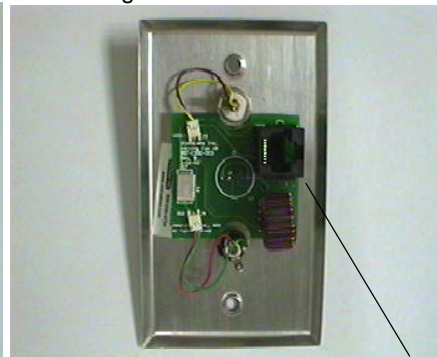

RJ-45 Jack

The composite video jack and the S-video jack are outputs and are connected to inputs of devices such as video conferencing systems, monitor/receivers, VCRs, LCD and DLP projectors, video switchers, video capture cards, video to USB adapters etc.....

**Note:** The S-Video and the composite video connectors on the Ceiling DocCam plate are both always live. It is possible to connect the camera to two separate viewing sources (i.e. a computer and monitor, or two monitors) at the same time.



## 1.4 IR Remote Control

The IR Remote Control for the Ceiling DocCam requires 2 'AAA' batteries. Pull up the battery cover tab and insert the batteries, making sure the battery +/- terminal symbols line up with the +/- symbols on the inside of the battery compartment. The VideoLabs IR Remote controls Power ON/OFF, Zoom-in and Zoom-out.

### Other IR Remote Controls

The Ceiling DocCam can be ordered to respond to the zoom-in and zoom-out commands of the Polycom® ViewStation IR Remote and the PictureTel® IR Keypad. Please see the VideoLabs Price List for model numbers and ordering information.

## 1.5 RS-232 Control

The Ceiling DocCam is equipped with a RS-232 control interface on a RJ-45 Jack (Figure 13). See **Appendix 1** for RS-232 control interface.

(NOTE: All ASCII commands require "carriage return" at the end of each statement)

Figure 13: RS-232 Control Jack and Pin-out Table

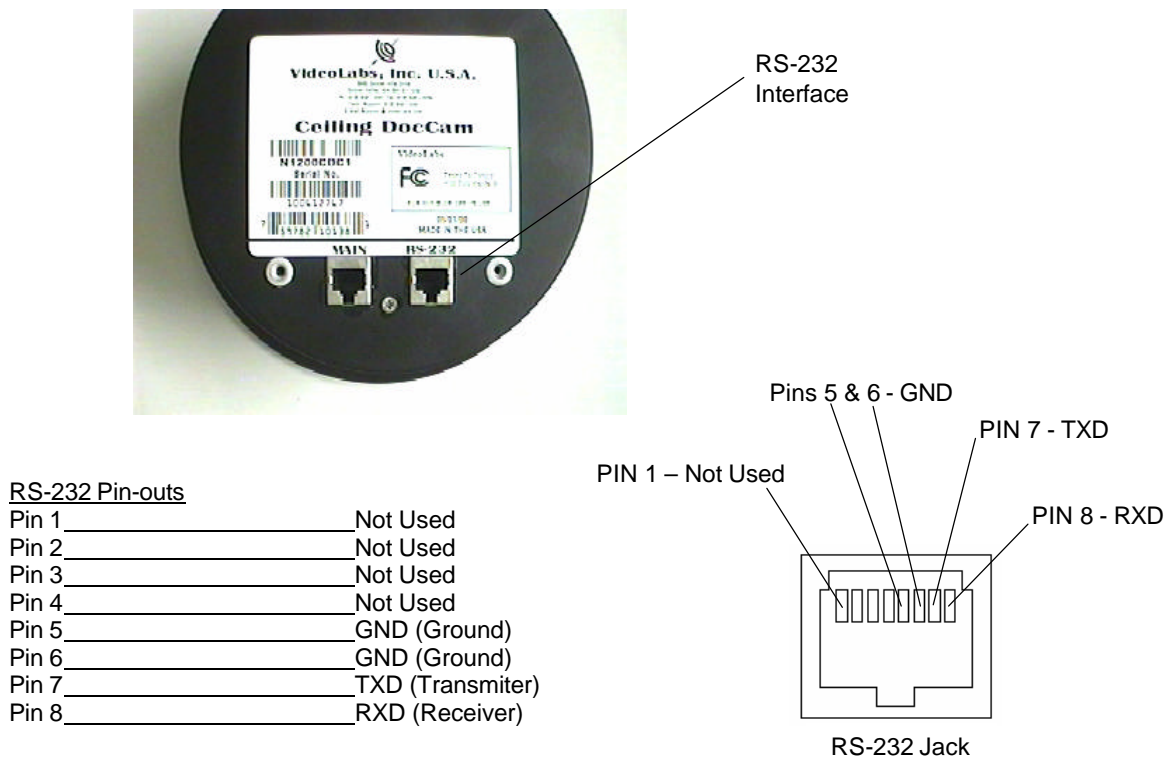

## 1.6 Care and Cleaning

1. Do not attempt to take the camera apart. There are no user-serviceable components inside.
2. Do not spill liquids onto the camera.
3. Avoid touching the lens. For smears or smudges, clear any dust with a blower and wipe stains with a glass cleaner and clean, soft cloth.
4. To clean exterior of camera, wipe with a clean damp cloth. Do not use any abrasive chemicals.

## 1.7 Operating and Storage Conditions

1. Do not store or operate the Ceiling DocCam under the following conditions:
  - ? Above 40°C (104°F) or below 0°C (32°F)
  - ? High humidity environments
  - ? Dusty environments
  - ? In inclement weather
  - ? Under severe vibration

## 2.0 Troubleshooting

Problem	Suggestion
No Video Image	<p>Verify that the 50' plenum rated RJ-45 plug-to-plug cable is connected between the "MAIN" jack on the back of the camera module enclosure and the RJ-45 jack on the back of the wall plate.</p> <p>Make sure the provided 12VDC power supply is plugged into a wall outlet and the "12 V DC" jack on the wall plate. Do not use any other power supply.</p> <p>Check the video connections to verify they are tight and fully inserted.</p> <p>Check the input on the video device (ie...monitor, VCR, video conferencing system...), verify it's power-on condition and assign the input accordingly.</p>
The IR remote control does not work.	<p>Verify fresh batteries are installed and in the correct position.</p> <p>Remove power supply plug from the "12 V DC" jack on the wall plate. Wait a few seconds and reinsert the power supply plug.</p> <p>The Ceiling DocCam can be purchased to respond to the VideoLabs IR Remote, or the Polycom ViewStation IR Remote or the PictureTel IR Keypad. Verify the model number on the back of the camera module enclosure to determine which IR Remote you have chosen for your installation and use that remote only.</p>

### 3.0 Technical Specifications:

Image Pick-up Device	¼" CCD
Total Pixels	410,000
No. of Effective Pixels	768H x 494V
Horizontal Resolution	470 TV lines
Sensitivity	3 lux
Lens: (Horizontal angle)	F1.6 (w)-F3.8 (t) [47° (w)-2.2°(t)]
Mechanical Zoom	F=4-88mm; 22X Optical,
Digital Zoom	44X Digital (X2 continuous)
Video Output	S-Video and Composite (concurrent)
Illumination S/N (min)	50dB
White Balance	Auto
Back Light Compensation	Auto
Iris	Auto
Shutter	Auto Exposure
Focus	Auto
Focal Range	Infinity-1m(T)-0.01m(w)
Current Consumption	300mA
Control	IR Remote or RS-232C
Operating Temperature	0°C to 40°C
Weight	4 lbs/1.81kg
Dimensions	4.5" (11.43cm) Tall & 6.5" (16.51cm) Diameter
Ceiling Cut-out	3.5" (8.89cm) in Diameter
Trim Ring	5.5" (13.97cm) in Diameter, Ceiling White
Wall Plate	S-Video/Composite/Power
Cables	50' Shielded Plenum Cat. 5 RJ-45 Cable, 25' S-Video (S-VHS) Cable, RCA Jack to BNC Plug Adapter
Power Supply	12VDC
Enclosure	Plenum Rated Conforming to UL Std. 1480 and NFPA Std. 72A

## **4.0 Warranty Information on Hardware**

VideoLabs warrants this product against defects in materials and workmanship for a period of one (1) year from the date of purchase. If VideoLabs receives notice of such defects during the warranty period, VideoLabs will either, at its option, repair or replace products which prove to be defective.

### **Obtaining Warranty Service**

To obtain warranty service, products must be returned to a service facility designated by VideoLabs. Customer shall prepay shipping charges for products returned to VideoLabs for warranty service and VideoLabs shall pay for return of the products to customer. However, customer shall pay all shipping charges, duties and taxes for products returned to VideoLabs from another country.

### **VideoLabs Customer Service**

If the camera is still under warranty, VideoLabs will test, repair or replace the product without charge. If the camera is out-of-warranty, VideoLabs will test, then repair the product for the cost of parts and labor. Charges will be estimated and confirmed by the customer prior to repair by a VideoLabs' technician.

Repair time for all cameras is a maximum of 2 business days from receiving to outbound shipping. VideoLabs will not accept responsibility for shipment after the camera has left our premises.

### **VideoLabs Technical Support**

VideoLabs' technicians will determine and discuss with the customer the criteria for repair costs and/or replacement. Contact VideoLabs' Technical Support through one of these sources: phone: 800-467-7157 (U.S. only) or 763-542-0061, e-mail: support@videolabs.com or web site: [www.videolabs.com](http://www.videolabs.com)

### **RMA (Return Merchandise Authorization) Number**

Before returning a camera for repair or replacement, request an RMA number from VideoLabs Technical Support.

Provide the technician with a return phone number or email and a shipping address. Describe the product, the reason for repair or return, and the date of purchase.

Include your RMA number on all correspondence with VideoLabs. Write your RMA number on the outside of the box when you return the camera.

### **Voided Warranty**

This warranty does not apply if the VideoLabs serial number has been removed or if the product has been disassembled or damaged through misuse, accident, modifications, or unauthorized repair.

**Shipping and Handling**

VideoLabs will not pay for inbound shipping, transportation, or insurance charges, or accept any responsibility for loss and/or damage from inbound transit. VideoLabs requires that all overseas returns are shipped via UPS.

VideoLabs will pay for outbound shipping, transportation, and insurance charges but will not assume responsibility for loss and/or damage by the outbound freight carrier.

**Products Not Under Warranty**

Payment arrangements are required before outbound shipping for all products that are out-of-warranty.

**Exclusions**

The above warranty shall not apply to defects resulting from: improper or inadequate maintenance or installation by customer, customer-supplied software or interfacing; unauthorized modifications or misuse; operation outside of the environment specifications for the product; or improper site operation and maintenance.

All statements, technical information, and recommendations related to VideoLabs products are based on information believed to be reliable. Before using this product, you must evaluate it and determine if it is suitable for your intended application. You assume all risks and liability associated with such use.

VideoLabs MAKES NO OTHER WARRANTIES INCLUDING, BUT NOT LIMITED TO, ANY IMPLIED WARRANTY OF MERCHANTABILITY OR FITNESS FOR A PARTICULAR PURPOSE.

**Limitation of Liability**

Except where prohibited by law, VideoLabs will not be liable for any loss or damage arising from this product, whether direct, indirect, special, incidental or consequential regardless of the legal theory asserted.

## 5.0 Quick Connect Guide

1. First connect the 50' plenum rated, Category 5, RJ-45 plug to RJ-45 plug cable between the RJ-45 jack labeled MAIN on the back of the camera module enclosure and the RJ-45 jack on the back of the provided wall plate.
2. Connect the provided 12VDC power supply to the jack on the front of the plate labeled 12 V DC and plug the power supply into a standard 110V-120V electrical outlet. Use only the provided 12VDC power supply.
3. Connect the **Output** jacks labeled S-VIDEO or COMPOSITE to the **Inputs** of video devices such as video conferencing systems, monitor/receivers, VCRs, LCD and DLP projectors, video switchers, video capture cards, video to USB adapters etc..  
Note: Both S-VIDEO and COMPOSITE outputs are live.
4. Put Batteries in the IR Remote Control and turn the camera ON.
5. Use the IR Remote Control to zoom in & out on the document/object positioned under the Ceiling DocCam.

