

AP 10



Telephone Interface



Installation & Operation Manual

Gentner[®]

Perfect Communication through Technology, Service, and Education.[™]

AP10 Telephone Interface Installation and Operation Manual
Gentner Part No. 800-150-201
May 2001 (Rev. 1.1)

©2001 Gentner Communications Corporation. All rights reserved. No part of this manual may be reproduced in any form or by any means without written permission from Gentner Communications Corporation. Printed in the United States of America. Gentner Communications Corporation reserves specification privileges. Information in this manual is subject to change without notice.

T able of Contents

Introduction1

- Congratulations1
- Product Registration2
- Technical Support2
- Features3
- Unpacking3
- Controls and Connections4
 - Front View4
 - Rear View4
 - Touch-Tone Dialing5
- Before You Install6
 - Power Requirements6
- Installation7

Installation & Operation7

- Installation7
 - Connecting the Unit8
 - Creating a G-Link Network8
 - Assigning Device ID Numbers9
 - Connecting Power9
- DIP Switch Settings10
 - DIP Switch 1, Noise Burst/Auto-Adapt10
 - DIP Switch 2, 6dB Receive Boost10
 - DIP Switch 3, Receive Automatic Gain Control11
 - DIP Switch 4, Auto-Answer11
 - DIP Switch 5, Auto-Disconnect11
 - DIP Switch 6, Call Progression/Loop11
 - DIP Switch 7, Receive Reduction12
 - DIP Switch 8, Hook-Flash Duration12
- Calibration12
 - Noise-Burst Adapt13
 - Auto-Adapt13
 - Transmit Level Adjustment13
 - Receive Level Adjustment13

Operating Your AP1014
 Answering a Call14
 Making a Call14
 Disconnecting a Call14
 Remote Connector (DB25) Option15
 Custom Controller Option15
 When Not in Use15

Appendix A17
Specifications17
Warranty19
 FCC Part 15 Compliance20
 FCC Part 68 Compliance21
 IC Compliance22
 Safety Information22

Appendix B23
Pinouts23
 Remote Connector Pinout23
 Line Connector Pinout23
 Set Connector Pinout24

Appendix C25
Serial Commands25
 AP800 RS232 Serial Port Default Protocol25
 Command Syntax26
 AA26
 DIAL27
 HOOK27
 LVL28
 MUTE28
 NULL29
 RING29
 TE29
 TERL29
 TERLE30
 UID30
 VER30
Block Diagram31

1 Introduction

Congratulations

Congratulations on purchasing the Audio Perfect™ 10 (AP10) telephone interface. The AP10 uses the latest digital technology to maintain the highest possible quality audio. The AP10 is designed as an accessory to the Audio Perfect 800 (echo cancelling, audio processing, microphone mixing matrix) to add telephone lines into audioconferences.

The AP10 is a single-line digital hybrid which uses digital-signal processing (DSP) to separate the transmit and receive audio, eliminating distortion, weak signals, and feedback. It continually filters low and high frequency noise to provide pure sound.

This manual explains how to install, set up and operate the AP10 in a step-by-step format. It also supplies instructions on how to resolve technical problems, should any arise.

Technical Support

If you need any additional information on how to install, set up or operate your system, please contact us at one of the locations noted below. We welcome and encourage your comments so we can continue to improve our products and serve your needs.

Gentner Communications Corporation

1825 Research Way, Salt Lake City, UT 84119

Telephone: 1.800.945.7730(USA) or 1.801.975.7200

Fax: 1.801.977.0087

E-mail: tech2@gentner.com

Web site: www.gentner.com

Sales and Customer Service

Telephone: 1.800.945.7730 (USA) **or** 1.801.975.7200

Fax: 1.800.933.5107 (USA) **or** 1.801.977.0087

E-mail: products@gentner.com

Gentner Communications EuMEA GmbH

Leonhardstr. 16-18, D-90443 Nuremberg, Germany

Telephone: +49 911 955159-0

Fax: +49 911 955159-10

E-mail: sales@gentner.com

Product Registration

Please register your AP10 online by visiting Gentner Technical Support at **www.gentner.com**. When your product is properly registered, Gentner Communications is better able to serve you should you require technical assistance. Registration information is also used to notify you of upgrades, new product information, etc.

Unpacking

Ensure that the following items (See Figure 1, below) were received with your shipment:

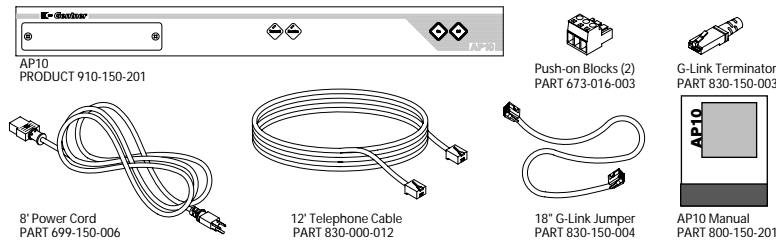

Figure 1. Equipment diagram

! Gentner Communications is not responsible for product damage incurred during shipment. You must make claims directly with the carrier. Inspect your shipment carefully for obvious signs of damage. If the shipment appears to be damaged, retain the original boxes and packing material for inspection by the carrier. Contact your carrier immediately.

Features

- Easy to install and operate
- DTMF dialing capability
- Simultaneous two-wire/four-wire operation within an Audio Perfect™ system
- G-Link network interconnection with up to eight AP800s and 16 AP10s.
- 9.6kHz sampling rate allows continual adaptation to telephone-line conditions
- Full-time telco echo cancellation with 26 millisecond tail time
- Conference up to 16 callers (with 16 AP10s) within an Audio Perfect™ system
- Digital anti-alias filter minimize hum and Central Office switching noise
- Remote ON/OFF control via serial commands or rear-panel connection
- Digital send filter/limiter for telephone line-noise reduction
- Compatible with any analog telephone system
- No outside RF interference will affect performance

Controls and Connections

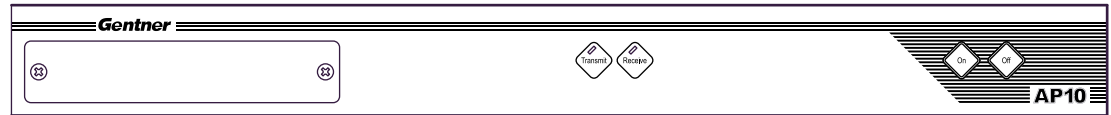

Figure 2. AP10 front-panel controls

Front View

The AP10 front-panel controls (see Figure 2, above) perform the following functions:

1. **Transmit LED** This bicolor LED indicates the audio levels being transmitted from the room to the telephone line.
2. **Receive LED** This bicolor LED indicates the audio level the room is receiving from the telephone line.
3. **On LED** This bicolor LED indicates the hybrid's ON state. The LED will illuminate green when the hybrid is in the ON state.
4. **Off LED** This bicolor LED indicates the hybrid's OFF state. The LED will illuminate red when the hybrid is in the OFF state.
5. **On** The ON button (momentary), connects the hybrid to the telephone line (dependent upon DIP switch settings), and automatically adapts the hybrid to the line. Pressing and holding the ON button for more than a half-second while the hybrid is active will readapt the hybrid.
6. **Off** The OFF switch (momentary), disconnects the hybrid from the telephone line and mutes all audio.

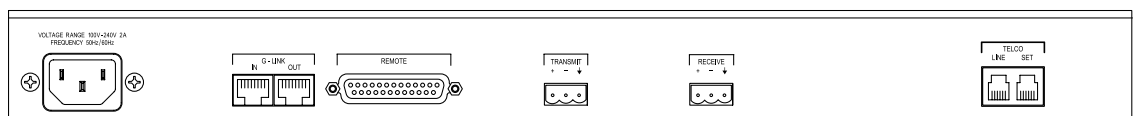

Figure 3. AP10 back-panel connectors

Rear View

The AP10 back-panel connectors (see Figure 3, above) perform the following functions:

1. **Power** The AC power cord input is a NEMA type connector allowing 100–240VAC, 50/60Hz.

2. **G-Link In** This RJ-45 connector is part of the G-Link RS-485 LAN that provides serial control and status of the hybrid. The first Gentner unit in the local G-Link network must terminate G-LINK IN with a G-Link terminator. Other Gentner units in the local G-Link network must connect the previous Gentner unit's G-LINK OUT to the next Gentner unit's G-LINK IN connector.
3. **G-Link Out** This RJ-45 connector is part of the G-Link RS-485 LAN that provides serial control and status of the hybrid. The last Gentner unit in the local G-Link network must terminate G-LINK OUT with a G-Link terminator. Other Gentner units in the local G-Link network must connect the following Gentner unit's G-LINK IN to the previous Gentner unit's G-LINK OUT connector.
4. **Remote** This DB25 connector provides control and status of the AP10.
5. **Transmit Input** This Phoenix™ connector is for connecting transmit audio (input) with the three-terminal Phoenix push-on connector to the AP800. Note that each position has three possible wiring positions: + (positive), - (negative) and Ú (ground).
6. **Receive Output** This Phoenix connector is for connecting receive audio (output) with the three-terminal Phoenix push-on connector from the AP800. Note that each position has three possible wiring positions: + (positive), - (negative) and ↓ (ground).
7. **Line** This RJ-11 connector provides connection of a standard analog telephone line to the hybrid.
8. **Set** This RJ-11 connector allows connection to a standard telephone set. Tip and ring from the phone line are present at this connector when the hybrid is in its Off state. Tip and ring from the phone line are not present at this point when the hybrid is in its On state.

Touch-Tone Dialing

Through the G-Link (and serial commands), the AP10's touch-tone (DTMF) dialing capability can be accessed. This allows outbound calls to be initiated by the AP10 without requiring an external dialer or telephone set. This feature continues to function after connection, enabling the user to issue tones for voice mail/pager interaction.

Before You Install

Power Requirements

The AP10 automatically accommodates voltage requirements of 100–240VAC, 50/60Hz, 30W.

Telephone Line Requirements

The AP10 model operates on a standard analog telephone line and connects to the telephone system with a standard RJ-11C modular jack. If you do not have an RJ-11C jack where you want to install your AP10, call your telephone company for installation.

Equipment Placement

The AP10 models are designed for installation into a standard 19-inch equipment rack.

The AP10 is designed for easy installation and setup. All necessary interface connections are made through rear-panel connectors. This makes for easy installation, removal and, if necessary, service.

2 Installation & Operation

Installation

The AP10 is designed for easy installation and setup. All necessary interface connections are made through rear-panel connectors. This makes for easy installation, removal and, if necessary, service.

The following block diagram (see Figure 4, below) shows the AP10 when installation is complete in an Audio Perfect system.

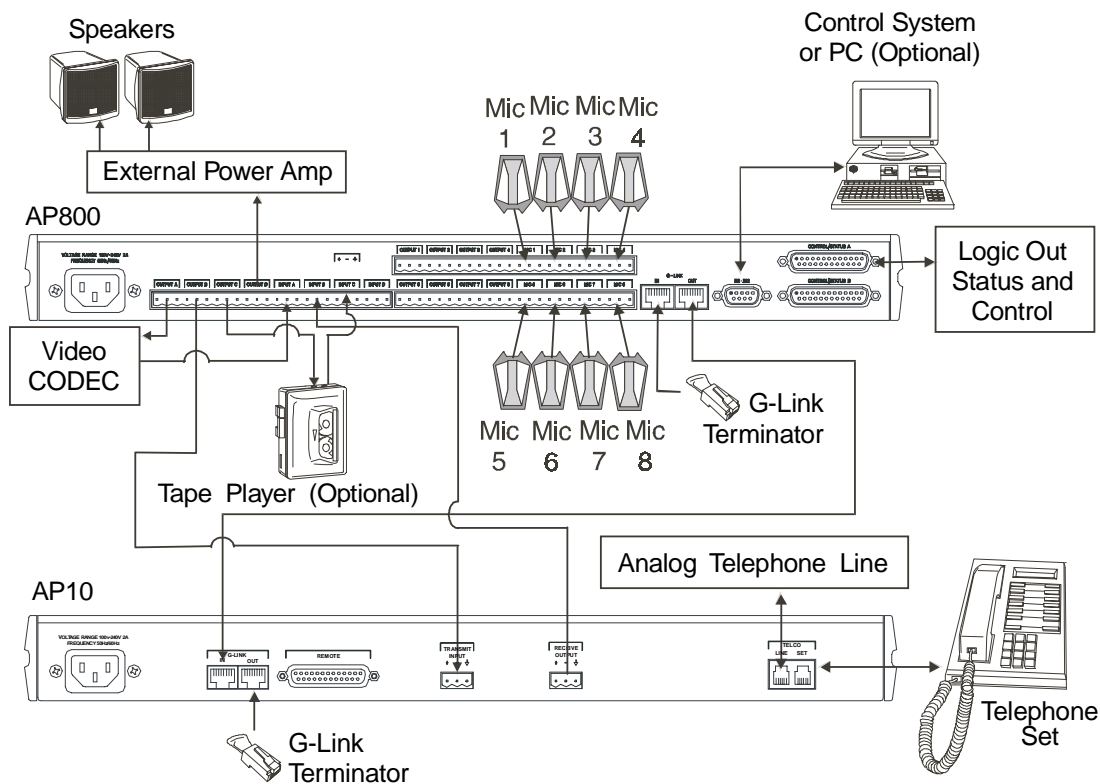

Figure 4. System block diagram

Connecting the Unit

Refer to AP10 back-panel connections (See Figure 5, below) for a description and placement of each of the connections you will be making. Each connector is numbered for easy identification. To install your AP10, follow these step-by-step instructions:

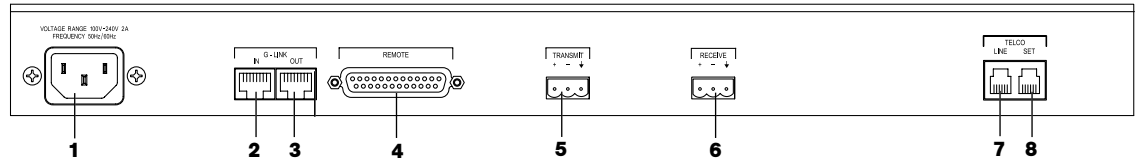

Figure 5. AP10 back-panel connectors

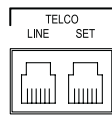

Figure 6. RJ-11C telephone-line connector

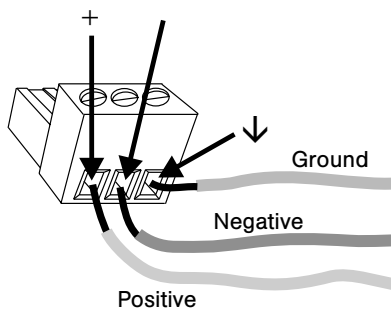

Figure 7. Phoenix push-on connector

1. Plug your telephone line from the wall jack into the RJ-11C Line jack [7].
2. Plug your telephone set into the RJ-11C Set jack [8].
3. If you are using a remote control for parallel control and hybrid status, plug it into the DB25 Remote connector [4].
4. Wire the AP800 to the AP10 using the provided three-terminal Phoenix push-on connectors. These connectors are designed for easy wiring; simply insert the desired wire into the appropriate connector opening and tighten down the top screw.

- **Transmit Input** Audio connected to the Transmit Input [5] will be sent down the telephone line.
- **Receive Output** Audio from the Receive Output [6] (telephone participant audio) is passed to the AP800 for further routing and distribution. See Figure 4 on page 7.



The three terminals in the Phoenix connector correspond with the back-panel audio contacts (from left to right): + (positive), - (negative), and ⏚ (ground).

Creating a G-Link Network

1. Place the AP units in their proper locations. The back-panel G-Link In [2] and G-Link Out [3] connectors are designed for setting up your G-Link network. G-Link connections between AP units are connected in daisy-chain fashion using category five twisted-pair cable.

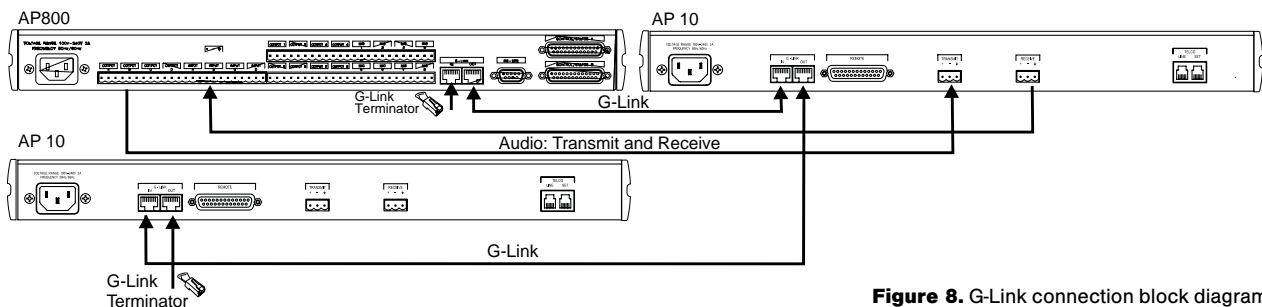

Figure 8. G-Link connection block diagram

2. The first Gentner unit in the chain must have the G-Link In connector [2] terminated with a G-Link terminator (provided).
3. The first Gentner unit's G-Link Out connector [3] is then attached to the G-Link In [2] connector on the next unit in the chain. At the end of the network, the final unit must have the G-Link Out connector [3] terminated with a G-Link terminator as well.

A G-Link network will allow interconnection of up to 16 AP10s and eight AP800s.



If the Gentner units to be networked are stacked vertically, connect them using the short RJ-45 jumper (provided). If networking Gentner units (maximum distance 20 feet between units), we recommends that category five twisted-pair (10BaseT LAN) cable be used.

Assigning Device ID Numbers

Once your physical G-Link network is established, you need to set up unique G-Link device ID numbers for each AP10 on the network. As shipped from the factory, all AP10 units default as binary address 0. Set device ID numbers for each AP10 unit at your site by manipulating front-panel DIP switches 9–12, selecting/deselecting each switch to set up address 0–15 in binary code. Table 1 (below) illustrates how this is done.



If more than one AP10 is assigned the same device ID number, the Transmit and Receive LEDs will flash on the affected units until the error is corrected.

Table 1. Device ID DIP Switch Settings

Binary Address	DIP Switch 9 Position	DIP Switch 10 Position	DIP Switch 11 Position	DIP Switch 12 Position
0	0 (DOWN)	0 (DOWN)	0 (DOWN)	0 (DOWN)
1	0 (DOWN)	0 (DOWN)	0 (DOWN)	1 (UP)
2	0 (DOWN)	0 (DOWN)	1 (UP)	0 (DOWN)
3	0 (DOWN)	0 (DOWN)	1 (UP)	1 (UP)
4	0 (DOWN)	1 (UP)	0 (DOWN)	0 (DOWN)
5	0 (DOWN)	1 (UP)	0 (DOWN)	1 (UP)
6	0 (DOWN)	1 (UP)	1 (UP)	0 (DOWN)
7	0 (DOWN)	1 (UP)	1 (UP)	1 (UP)
8	1 (UP)	0 (DOWN)	0 (DOWN)	0 (DOWN)
9	1 (UP)	0 (DOWN)	0 (DOWN)	1 (UP)
10 (A)	1 (UP)	0 (DOWN)	1 (UP)	0 (DOWN)
11 (B)	1 (UP)	0 (DOWN)	1 (UP)	1 (UP)
12 (C)	1 (UP)	1 (UP)	0 (DOWN)	0 (DOWN)
13 (D)	1 (UP)	1 (UP)	0 (DOWN)	1 (UP)
14 (E)	1 (UP)	1 (UP)	1 (UP)	0 (DOWN)
15 (F)	1 (UP)	1 (UP)	1 (UP)	1 (UP)

Connecting Power

The power input [1] will operate at any level between 100–240VAC, 50–60Hz, 30W. Plug in the AP10 to complete the hardware installation.

DIP Switch Settings

The AP10 has a variety of operational features configurable through DIP switch settings, including noise burst/auto-adapt, receive AGC control, auto-answer, auto-disconnect, call progression/loop, receive reduction, and hook-flash duration. Default settings (as shipped from the factory) are denoted by an asterisk “*”.

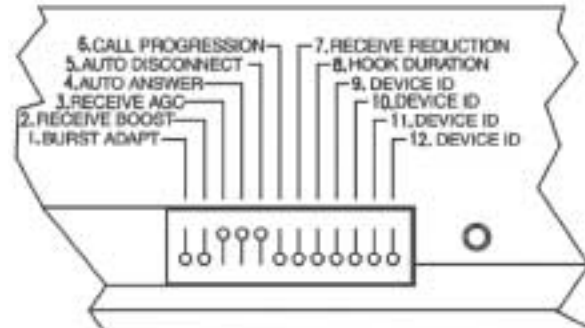

DIP Switch 1, Noise Burst/Auto-Adapt

In some applications, it may be desirable to adapt the hybrid with a white-noise burst, rather than allowing the hybrid to adapt automatically to line conditions. To enable this feature, DIP switch 1 behind the digital hybrid's front panel is used to enable/disable the noise burst (Table 2, below).

Table 2. Noise Burst Auto-Adapt DIP Switch Settings

DIP Switch	Position	Description
1	ON (UP)	Burst adapt
1*	OFF (DOWN)	Auto-adapt

DIP Switch 2, 6dB Receive Boost

In some applications, it may be desirable to increase the receive audio by 6dB. To enable this feature, DIP switch 2 behind the digital hybrid's front panel is used to enable/disable the 6dB receive boost (Table 3, below).

Table 3. 6dB Receive Boost DIP Switch Settings

DIP Switch	Position	Description
2	ON (UP)	6dB Receive audio boost enabled
2*	OFF (DOWN)	6dB Receive audio boost disabled

DIP Switch 3, Receive Automatic Gain Control

DIP switch 3 behind the digital hybrid's front access panel enables/disables the AGC function in the firmware (Table 4, below).

Table 4. Receive AGC DIP Switch Settings

DIP Switch	Position	Description
3*	ON (UP)	Receive AGC enabled
3	OFF (DOWN)	Receive AGC disabled

DIP Switch 4, Auto-Answer

DIP switch 4 behind the AP10's front access panel enables/disables auto-answer (Table 5, below).

Table 5. Auto-Answer DIP Switch Settings

DIP Switch	Position	Description
4	ON (UP)	Auto-answer enabled
4*	OFF (DOWN)	Auto-answer disabled (follows the serial command)



To issue the AA (auto-answer) serial command to toggle auto-answer, DIP switch 4 must be OFF (DOWN).

DIP Switch 5, Auto-Disconnect

DIP switch 5 behind the AP10's front access panel enables/disables auto-disconnect (Table 6, below).

Table 6. Auto-Disconnect DIP Switch Settings

DIP Switch	Position	Description
5*	ON (UP)	Auto-disconnect enabled
5	OFF (DOWN)	Auto-disconnect disabled



In order for the settings on DIP Switch 6 to function, DIP Switch 5 must be ON (UP). Auto-disconnect must be enabled before either Call Progression or Loop Drop are applicable.

DIP Switch 6, Call Progression/Loop

DIP switch 6 selects either loop drop or call-progress mode. Call-progress mode will disconnect the line upon detection of a valid call-progress signal (Table 7, below). Call progress will detect reorder tone and busy for the U.S., Canada, United Kingdom, France, and Germany.

Table 7. Call Progression/Loop DIP Switch Settings

DIP Switch	Position	Description
6	ON (UP)	Call progression enabled
6*	OFF (DOWN)	Loop drop enabled

DIP Switch 7, Receive Reduction

In some applications, it may be necessary to duck the receive audio coming in through the telephone line when transmit audio is present. To serve this purpose, DIP switch 7 is designated to duck the receive audio by -6dB, if active (Table 8, below).

Table 8. Receive Reduction DIP Switch Settings

DIP Switch	Position	Description
7	ON (UP)	Receive reduction enabled
7*	OFF (DOWN)	Receive reduction disabled

DIP Switch 8, Hook-Flash Duration

DIP switch 8 selects either a 50 millisecond or 500 millisecond hook-flash duration (Table 9, below).

Table 9. Hook-Flash Duration DIP Switch Settings

DIP Switch	Position	Description
8	ON (UP)	50 milliseconds
8*	OFF (DOWN)	500 milliseconds

Calibration

The following information will help you make adjustments to optimize your system performance. Verify all components and all connections. Ensure that proper power is supplied to the AP10 and that the unit is OFF (the red OFF LED [4] will be lit; Figure 12, below). If the green ON LED [3] is lit, press the OFF button [6].

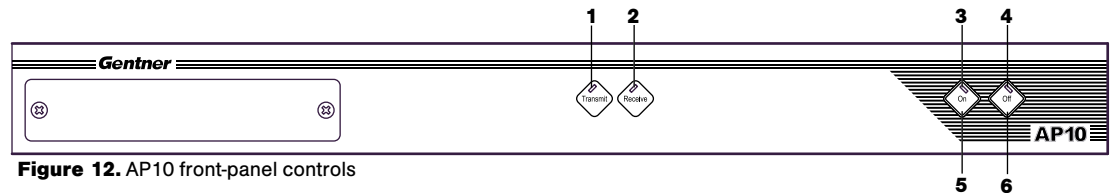

Figure 12. AP10 front-panel controls



Some echo and ringing may be heard while calibrating the AP10. Disregard it and continue with calibration until the end of the procedure. The echo and ringing will disappear.

There are two calibration methods for the AP10: noise burst and auto-adapt. Which procedure is used depends on whether you have DIP switch 1 ON (UP) for noise-burst adapt, or DIP switch 1 OFF (DOWN) for auto-adapt. Either will suffice to calibrate the AP10. The difference is the application and/or personal preference. Some applications are not suited for a .75-second noise burst, and may require the gradual adaptation over time.

Noise-Burst Adapt

If DIP switch 1 is ON (UP), have someone call the AP10 from another location. Answer the line by pressing the ON button [5]. (If the auto-answer feature is active, the unit will answer the call after one complete ring.)

The caller will hear a short white noise burst (it will sound like static) and a short beep. This automatically adapts the AP10 to the telephone line.

Auto-Adapt

If DIP switch 1 is OFF (DOWN), call someone and continue to talk while the system gradually adapts over time. Once complete, the AP10 will be fully calibrated and ready for use.

Conclude your conversation and press the OFF button [6]. (If the auto-disconnect feature is active, and the distant location hangs up, the AP10 will disconnect upon sensing loop drop or call-progress tones, depending on the position of DIP switch 6.)

Transmit Level Adjustment

Someone in the local room should speak into the microphone at a normal distance, in a normal voice. The party at the distant location should not speak during the transmit adjustment. Adjust the AP800 output that is connected to the AP10 TRANSMIT input to 0dB. The AP10 TRANSMIT LED [1] should be solid green while the person is speaking and extinguish when the person stops.

Receive Level Adjustment

Someone in the distant location should speak into the microphone at a normal distance, in a normal voice; the local room should maintain silence. Adjust the AP800 input that is connected to the AP10 RECEIVE output to 0dB. The AP10 RECEIVE LED [2] should be solid green while the person is speaking and extinguish when the person stops.

Calibration is now complete.



AP10 transmit and receive audio level adjustments are made via the AP800.

Nominal transmit and receive level for the AP10 is 0dB.

Operating Your AP10

Easy-to-access front-panel controls make operation of the AP10 simple. Figure 12a (below) shows each front panel LED and button by number.

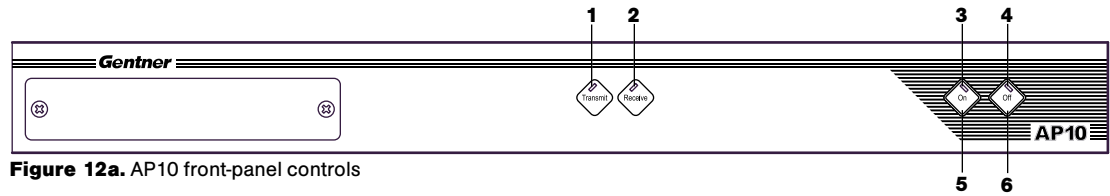

Figure 12a. AP10 front-panel controls

Answering a Call

An incoming call will ring on the telephone set connected to the AP10 and flash the ON LED. You can answer the call in one of two ways:

- Press the ON button [5] on either the front panel or from your remote control. This will route the call through the AP10 to the AP800. The green ON LED [3] will light. The red OFF LED [4] will dim. Upon connection, the AP10 automatically (method of adaptation depends on the position of DIP switch 1) adjusts to the line conditions.
- Answer the call by picking up the telephone handset and talking to your party over the telephone.

Making a Call

Call the party normally, using your handset. After the other party has answered, route the call through the AP10 by pressing the ON button [5]. The ON LED [3] will light and the AP10 will take control of the call, disabling the telephone set. You may now safely hang up the handset without disconnecting your call. When the conversation is complete, press the OFF button [6] to disconnect the call.

If using RS232 touch tone, it is not necessary to hit the ON button [5]. When using the DIAL serial port command, the AP10 automatically engages the hybrid. See Serial Commands, page 27.

Disconnecting a Call

If the call is routed through the AP10 (the ON LED [3] will glow), press the OFF button [6] (OFF LED [4] will glow, ON LED [3] will extinguish).

If your call is through the handset only (the red OFF LED [4] will be lit), hang up when the conversation is complete.



If auto-answer is enabled (DIP switch 4), the AP10 will answer after the first

complete ring.



If auto-disconnect is enabled (DIP switch 5), the AP10 will disconnect upon

sensing loop drop or call-progress tones (depending on the position of DIP switch 6).

Remote Connector (DB25) Option

A customer-supplied remote control or contact-closure switch can be used to perform three functions: mute on/off, system on, and system off. For pinouts, see Connector Pinouts, page 25.

Custom Controller Option

The AP products are designed to function with serial custom control systems. The controller is connected to the AP800 RS232 port. Via the G-Link network, all AP products can be accessed and controlled from that single point.

Via the custom controller, the AP10 can be turned on or off; transmit and receive audio can be muted; DTMF tones can be generated (See Serial Commands, Page 27); receive audio volume can be raised or lowered; the AP10's binary address can be queried; telephone hybrid can be renulled; input and output can be metered; and ERL and ERLE can be read. These commands are also available in the AP Tools software which communicates with the AP10 via an AP800 RS232 serial port and the G-Link LAN.

When Not in Use

The AP10 is inactive when the red OFF LED [4] lit.

A Appendix A

Specifications

Dimensions

17"/43.2cmW x 1.75"/4.5cmH x 8"/25.4cmD

Weight

7 lb/3.18 kg (dry) 12 lb./5.4 kg (shipping)

Connectors

POWER:	Auto-adjusting power module from 100–240VAC, 50/60Hz
REMOTE:	DB25 female connector.
G-LINK IN:	RS-485; 38.4kbps; 110kOhm impedance, category-five twisted-pair cable; 20-foot limit between networked units
G-LINK OUT:	RS-485; 38.4kbps; 110kOhm impedance, category-five twisted-pair cable; 20-foot limit between networked units
TRANSMIT INPUT:	Push-on terminal block with slotted set-screw connectors contacts provided at terminal block at +20dBm maximum input, 0dBu nominal level, >20kOhm impedance
RECEIVE OUTPUT:	Push-on terminal block with slotted set-screw connectors contacts provided at terminal block at +20dBm maximum input, 0dBu nominal level, <50 Ohm impedance
LINE:	RJ-11 connector
SET:	RJ-11 connector

Power Requirements

100–240VAC, 50/60Hz, 30W

Audio Performance

Frequency Response:	1 dB from 250Hz to 3.5kHz (with AGC disabled)
Signal-to-Noise Ratio:	>56dB reference to 0dBu at -15dBm on the telephone line
Receive Audio Distortion	<.3% THD, 250Hz to 3.5kHz (AGC disabled)

Audio Interface

Unbalanced Transmit Audio:	DB25; 0dB level input with a >10kOhm impedance
Unbalanced Receive Audio:	DB25; 0dB level output with a <50 Ohm impedance
Remote Control:	Momentary closures to the switch common.

Transmit and Receive Presence Indication

Open collector outputs go low when transmit and/or receive levels are present

Operating Temperature

32–100° F / 0–38° C

Humidity

0–80 percent

All specifications are subject to change without notice.

Warranty

Gentner Communications Corporation (Manufacturer) warrants that this product is free of defects in both materials and workmanship. Should any part of this equipment be defective, the Manufacturer agrees, at its option, to:

A. Repair or replace any defective part free of charge (except transportation charges) for a period of one year from the date of the original purchase, provided the owner returns the equipment to the Manufacturer at the address set forth below. No charge will be made for parts or labor during this period;

B. Furnish replacement for any defective parts in the equipment for a period of one year from the date of original purchase. Replacement parts shall be furnished without charge, except labor and transportation.

This Warranty excludes assembled products not manufactured by the Manufacturer whether or not they are incorporated in a Manufacturer product or sold under a Manufacturer part or model number.

THIS WARRANTY IS VOID IF:

A. The equipment has been damaged by negligence, accident, act of God, or mishandling, or has not been operated in accordance with the procedures described in the operating and technical instructions; or,

B. The equipment has been altered or repaired by other than the Manufacturer or an authorized service representative of the Manufacturer; or,

C. Adaptations or accessories other than those manufactured or provided by the Manufacturer have been made or attached to the equipment which, in the determination of the Manufacturer, shall have affected the performance, safety or reliability of the equipment; or,

D. The equipment's original serial number has been modified or removed.

NO OTHER WARRANTY, EXPRESS OR IMPLIED, INCLUDING WARRANTY OF MERCHANTABILITY OR FITNESS FOR ANY PARTICULAR USE, APPLIES TO THE EQUIPMENT, nor is any person or company authorized to assume any warranty for the Manufacturer or any other liability in connection with the sale of the Manufacturer's products.

Manufacturer does not assume any responsibility for consequential

damages, expenses, or loss of revenue or property, inconvenience, or interruption in operation experienced by the customer due to a malfunction in the purchased equipment. No warranty service performed on any product shall extend the applicable warranty period.

In case of unsatisfactory operation, the purchaser shall promptly notify the Manufacturer at the address set forth below in writing, giving full particulars as to the defects or unsatisfactory operation. Upon receipt of such notice, the Manufacturer will give instructions respecting the shipment of the equipment, or such other matters as it elects to honor this warranty as above provided. This warranty does not cover damage to the equipment during shipping and the Manufacturer assumes no responsibility for such damage. All shipping costs shall be paid by the customer.

This warranty extends only to the original purchaser and is not assignable or transferable.

**Gentner Communications Corporation, 1825 Research Way, Salt
Lake City, Utah 84119**

Compliance

FCC Part 15 Compliance

This equipment has been tested and found to comply with the limits for a Class A digital device, pursuant to Part 15 of the FCC rules. These limits are designed to provide reasonable protection against harmful interference when the equipment is operated in a commercial environment. This equipment generates, uses, and can radiate radio frequency energy and, if not installed and used in accordance with the instruction manual, may cause harmful interference to radio communications. Operation of this equipment in a residential area is likely to cause harmful interference, in which case the user will be required to correct the interference at his/her own expense.

Changes or modifications not expressly approved by Gentner Communications Corporation could void the user's authority to operate the equipment.

FCC Part 68 Compliance**FCC Registration Number: FBIUSA-43110-BR-T****Ringer Equivalence Number (REN): 0.6B**

A label containing, among other information, the FCC registration number and Ringer Equivalence Number (REN) for this equipment is prominently posted on the top plate, near the rear of the equipment. If requested, this information must be provided to your telephone company.

USOC Jacks: This device uses RJ-11C and RJ21X terminal jacks.

The REN is used to determine the quantity of devices which may be connected to the telephone line. Excessive RENs on the telephone line may result in the devices not ringing in response to an incoming call. In most, but not all areas, the sum of the RENs should not exceed five (5). To be certain of the number of devices that may be connected to the line, as determined by the total RENs, contact the telephone company to obtain the maximum RENs for the calling area.

If this equipment causes harm to the telephone network, the telephone company will notify you in advance that temporary discontinuance of service may be required. If advance notice is not practical, the telephone company will notify the customer as soon as possible. Also, you will be advised of your right to file a complaint with the FCC if you believe it is necessary.

The telephone company may make changes in its facilities, equipment, operations, or procedures that could affect the operation of the equipment. If this happens, the telephone company will provide advance notice for you to make the necessary modifications in order to maintain uninterrupted service.

If you experience problems with this equipment, contact Gentner Communications Corporation, 1825 Research Way, Salt Lake City, Utah 84119, or by phone at (801) 975-7200 for repair and warranty information. If the trouble is causing harm to the telephone network, the telephone company may request you remove the equipment from the network until the problem is resolved.

No user serviceable parts are contained in this product. If damage or malfunction occurs, contact Gentner Communications for instructions on its repair or return.

This equipment cannot be used on telephone company provided coin service. Connection to Party Line Service is subject to state tariffs.

IC Compliance

NOTICE: The Industry of Canada label identifies certified equipment. This certification means that the equipment meets certain telecommunications network protective operational and safety requirements. The Department does not guarantee the equipment will operate to the user's satisfaction.

Before installing this equipment, users should ensure that it is permissible to be connected to the facilities of the local telecommunications company. The equipment must also be installed using an acceptable method of connection. In some cases, the company's inside wiring associated with a single line individual service may be extended by means of a certified connector assembly (telephone extension cord). The customer should be aware that compliance with the above conditions may not prevent degradation of service in some situations.

Repairs to certified equipment should be made by an authorized Canadian maintenance facility designated by Gentner Communications. Any repairs or alterations made by the user to this equipment, or equipment malfunctions, may give the telecommunications company cause to request the user to disconnect the equipment.

Users should ensure for their own protection that the electrical ground connections of the power utility, telephone lines and internal metallic water pipe system, if present, are connected together. This precaution may be particularly important in rural areas.

Ringer Equivalence Number (REN): 0.6B
IC Certification Number: 1970 11504 A

Safety Information

CAUTION: Users should not attempt to make such connections themselves, but should contact the appropriate electrical inspection authority, or electrician, as appropriate.

B Appendix B

Pinouts

Remote Connector Pinout

Pin	Description	Pin	Description
1	Remote ON *	14	ON indication **
2	Remote OFF *	15	OFF indication **
3	N/C	16	N/C
4	N/C	17	N/C
5	Switch/Indicator Common	18	Switch/Indicator Common
6	N/C	19	Transmit Presence Indicator **
7	N/C	20	Receive Presence Indicator **
8	N/C	21	Switch/Indicator Common
9	Unbalanced Transmit Audio Input (0dBu nominal)	22	Audio Common
10	Unbalanced Receive Audio Output (0dBu nominal)	23	Audio Common
11	N/C	24	Audio Common
12	N/C	25	Switch/Indicator Common
13	Audio Common		

* Remote control provided via contact closure to Switch/Indicator Common

** Remote indicators provided via open collector outputs to Indicator Common (<15V, <39mA)

Line Connector Pinout

Pin	Description	Pin	Description
1	To pin 6 of LINE RJ-11C	4	Ring
2	To pin 5 of LINE	5	To pin 2 of SET
3	Tip	6	To pin 1 of SET RJ-11C

Set Connector Pinout

<u>Pin</u>	<u>Description</u>	<u>Pin</u>	<u>Description</u>
1	To pin 6 of SET RJ-11C	4	Tip
2	To pin 5 of SET	5	To pin 2 of LINE
3	Ring	6	To pin 1 of LINE RJ-11C

C Appendix C

Serial Commands

The AP products accept serial commands via the AP800's serial port; the commands are then channeled along the G-Link network to all interconnected AP products. In the case of the AP10, the commands provide the same control as the front-panel controls, plus several others. The following commands pertain only to the AP10.

AP800 RS232 Serial Port Default Protocol

(9,600 (default), 19,200 or 38,400 baud, 8 bits, 1 stop bit, no parity)

The AP10, via custom controller, will issue DTMF tones in the form of telephone-keypad digits (0–9), the * and # keys (for dialing and accessing voice-mail/pager). Also via custom controller, the AP10 will accept serial commands outlined in Table 13 (below).

The structure of serial commands is as follows: “#” (which signifies the start of a command line), device ID, command, then any additional options in the order that they appear in the command descriptions on the following pages. For example, a command to enable auto-answer on AP10 device “0” would have the command line: #20 AA 1. In this command line, 2=AP10, 0=unit 0, AA=command, 1=on state). If a command calls for a “null” value, leave a blank in the command line (i.e. “#20 AA” would return the current state of auto-answer on device 20). Commands can be either UPPER CASE or lower case. Return values are always in upper case. In order for a command to be recognized by the serial port, the command must be terminated by a carriage return.

Serial Commands

Command Syntax

All command lines will be set off by the flag symbol “⌘”. The serial command line that follows the “⌘” uses the following typographic conventions:

Command Line Syntax

<X>	Parameters enclosed in “<>” indicate a mandatory parameter
[X]	Parameters enclosed in “[]” indicate an optional parameter
1-8	Parameters separated by a “-” indicate a range between the values
4,7,9	Parameters separated by a “,” indicate a list of available values
AA	Words in ALL CAPS bold indicate command text
<DEVICE>	Device type/number on G-Link network (valid combinations depend on connected devices: for an AP10, device type is 2, device number will always be 0–9, A–F, where A=10 and F=15). See Table 1, Device ID DIP Switch Settings (Page 6).

The command string will then be explained (where necessary), followed by the returned values and (where necessary) an example.

AP10 Serial Commands

Command	Function	Command	Function
AA	Auto-answer	RING	Ring acknowledgement
DIAL	Dial touch-tones	TE	Control/report the connect state of the unit
HOOK	Send hook-flash to the line	TERL	Return telephone ERL
LVL	Return transmit/receive level	TERLE	Return telephone ERLE
MUTE	Control/report mute status*	UID	Return unit identification number
NULL	Renulls AP10 to telephone line	VER	Return current version of software

AA

This command activates and deactivates the auto-answer feature.



This serial command only functions if DIP switch 4 is OFF (DOWN).

⌘ <DEVICE> AA <X>

Explanation: <X> is the action (i.e. auto-answer enable, auto-answer disable, current state)

X=0	Parameter disables auto-answer
X=1	Parameter enables auto-answer
X=2	Parameter to toggle the state from one state to the other (regardless of current state)
X= Null	Parameter to report back the current state.

DIAL

DTMF tones can be generated through the AP10. This capability remains active after a call is placed, so tones can be issued for use with voice mail and pagers.

If the AP10 is not connected when this command is issued, the unit will connect to the line first, then dial the tone(s).

```
# <DEVICE> DIAL <STRING>
```

Explanation: <STRING> is any valid combination of touch tone characters. A comma indicates a two-second pause. STRING has a maximum length of 40 characters. Valid characters are: 0 through 9, A,B,C,D, #, * and ,

Return Values: DIAL returns the dialed string of numbers. The string is returned after the command has been completed (i.e. dialed all the touch tones).

Example: The following command dials the number (801) 975-7200. A 9 and a pause is generated to get an outside line on a PBX.

The number is to be dialed on device #20.

```
#20 DIAL 9,8019757200
```

The following is returned out the serial port:

```
#20 DIAL 9,8019757200
```

HOOK

This command sends a momentary interruption in line seizure (hook flash) to the telephone line. This command is write only.

```
# <DEVICE> HOOK
```

Return Values: If hook flash succeeded, the following is returned out the serial port: <DEVICE> HOOK

Example:

The following command request hook flash from device 20:

```
#20 hook
```

The following is returned out the serial port:

```
#20 hook
```

LVL

This command reports back the transmit or receive level for a unit.

```
<DEVICE> LVL <CH>
```

Explanation: <CH> is which parameter to be measured.

CH=RXIN	Parameter for level from the telephone line
CH=RXOUT	Parameter for level from the AP10
CH=TXIN	Parameter for level into the AP10
CH=TXOUT	Parameter for level to the telephone line

Return Values: LVL will return the output level of the line channel in the same format as the command.

Example: If is current level for RXIN channel is -20dBu, the following is returned out the serial port:

```
<DEVICE> LVL RXIN -20
```

MUTE

This command controls or reports the mute status of a channel .

```
<DEVICE> MUTE <CH> <X>
```

Explanation:

<CH> is the channel(s) to be muted/unmuted.

CH=T	Parameter to apply to the transmit channel
CH=R	Parameter to apply to the receive channel
CH=*	Parameter to apply to both channels

<X> is the action (i.e. mute, unmute, report the mute state).

X=0	Set mute to off
X=1	Set mute to on (mute the selected channel)
X=2	Parameter to toggle the state from one state to the other (regardless of current state)
X=NULL	Report the current state of mute for the selected channel

Return Values: MUTE returns the mute status in the same format as the command.

Example

If current state of mute for channel T is muted, the following is returned out the serial port: <DEVICE> MUTE T 1

If current state of mute for channel T is unmuted, the following is returned out the serial port: <DEVICE> MUTE T 0

NULL

This command sends a short noise burst down the telephone line and forces the AP10 to adapt to the telephone line. This command is write only.

 <DEVICE> **NULL**

Return Values

If the renull succeeded, the following is returned out the serial port:

<DEVICE> NULL

RING

When the AP10 receives a ring at the dialed-up location, the AP10 will respond

 RING

TE

Controls and reports the connection status of the unit.

 <DEVICE> **TE** <X>

Explanation

<X> is the action (i.e. connect, disconnect, current state)

X=0	Parameter to set the unit to disconnect from the line
X=1	Parameter to set the unit to connect to the line
X=2	Parameter to toggle the state from one state to the other (regardless of current state)
X= Null	Parameter to report back the current state.

Return Values

If the current connect state is ON, the following is returned out the serial port:

<DEVICE> TE 1

If the current connect state is OFF, the following is returned out the serial port:

<DEVICE> TE 0

Examples

The following connects the unit to the telephone line.

#20 TE 1

The following is returned out the serial port:

#20 TE 1

The following reports the connection state of the unit:

#20 TE

The following is returned out the serial port:

#20 TE 1

TERL

This command reports back the telephone echo return loss (ERL) for the AP10 in dB. This is a read-only parameter.

 <DEVICE> **TERL**

Return Values

If the current TERL level is 10 dB, the following is returned out the serial port:

<DEVICE> TERL 10

TERLE

This command reports back the telephone echo return loss enhancement (ERLE) for the AP10 in dB. This is a read-only parameter.

 <DEVICE> **TERLE**

Return Values

If the current TERLE level for the telephone canceller is 20dB, the following is returned out the serial port:

<DEVICE> TERLE 20

UID

This command returns the unique ID number of the unit. This command is read only.

 <DEVICE> **UID**

Return Values

UID returns the unit ID code. The Unit ID is composed of an eight-digit hex number (assigned at the factory) to uniquely identify the unit.

Example

This command requests the unit ID:
#20 UID

The following is returned out the serial port:
#20 UID A4EF906C

VER

This command returns current version of software. This version is unique to a released version of software. This command is read only.

 <DEVICE> **VER**

Return Values

VER returns the version of software (a major version number followed by a period and a minor version number).

Example

The following command request the unit ID from device 21
#20 VER

The following is returned out the serial port:
#20 VER 1.0

Block Diagram

