

# Control Panel

**ClearOne**

Provides convenient remote control of PSR1212 Digital Matrix Mixer and XAP 800/400 Audio Conferencing System. ClearOne's Control Panel triggers pre-programmed commands from the host unit, simplifying volume control, presets and macro executions.



## CONVENIENT REMOTE CONTROL OF PRESETS, MACROS AND VOLUME

### CONTROL PANEL APPLICATIONS

- Boardrooms
- Conference Rooms
- Classrooms
- Conference Halls
- Hotels and Convention Centers
- Public Address Systems
- Houses of Worship
- Room Combining Systems

### CONTROL PANEL ADVANTAGES

- Convenience
- + Provides remote control of zoning, volume and other functions of PSR1212 Digital Matrix Mixer and XAP 800/400 Audio Conferencing System
  - + Simplifies operation by executing pre-programmed commands
  - + Easy-to-use software programs each button to execute a function, command, series of commands, preset or macro
  - + Installs in a standard electrical switch-type wall box\*
  - + Can be combined in a 2, 3, or 4-ganged switch box.
  - + Comes with pre-punched facia plate, faceplate, PCB, connector blocks and low-voltage electrical box.
  - + Available in two models: Volume Control and Select Control.

#### Volume Control Panel

- + Volume up and down buttons
- + Seven easy-to-see LEDs indicating channel volume level
- + Programmable button for mute, combined, background music and more
- + Red status LED indicates execution of a command

#### Select Panel

- + Four programmable buttons
- + Four red status LEDs indicate execution of commands

Note: Control panel must not be used with an AC power switch or plug in the same box.

## > SPECIFICATIONS



**Dimensions (W x L)**  
1.8" x 4.13" / 4.6 x 10.5 cm

**Weight**  
1 lb/.45 kg

### Power Requirements

Each Control Panel requires +6-15VDC, 30mA operating current maximum. The PSR1212, XAP 800, and XAP 400 rear-panel Remote Panel connectors each provide +14.5 - 15.5VDC and 300mA of operating current.

### RS-485 Connector

Designed to function with the PSR1212, XAP 800, and XAP 400  
Cable type: Cat five or better  
Maximum Cable Length: See table below

### Data Connection Topology

Daisy Chain. Up to 12 Control Panels can be connected to a single PSR1212 or XAP 800/400 unite (up to six on each of two rear-panel RS-485 Phoenix connectors).

# of Control Panels	Maximum Distance
1	3,000 ft/914 m
2	2,500 ft/762 m
3	1,600 ft/488 m
4	1,200 ft/366 m
5	1,000 ft/305 m
6	800 ft/244 m

Maximum total category five cable run for each host unit Remote Panel connector. Based on cable with a nominal resistance of 27 ohms per 1,000' (305 meters). For information about extending beyond 800' (244 meters) total with six Control Panels, call Technical Support at 1-800-283-5936.

This equipment complies with the requirements of the European guidelines: 89/336/EEC

"Electromagnetic Compatibility" and 93/68/EEC "Electrical operating material for use within specific voltage limits". Conformity of the equipment with the above guidelines is attested by the CE mark.

This device complies with part 15 of the FCC rules. Operation is subject to the following two conditions: (1) This device may not cause harmful interference, and (2) this device must accept any interference received, including interference that may cause undesired operation. This equipment must be installed

according to applicable local electrical codes.

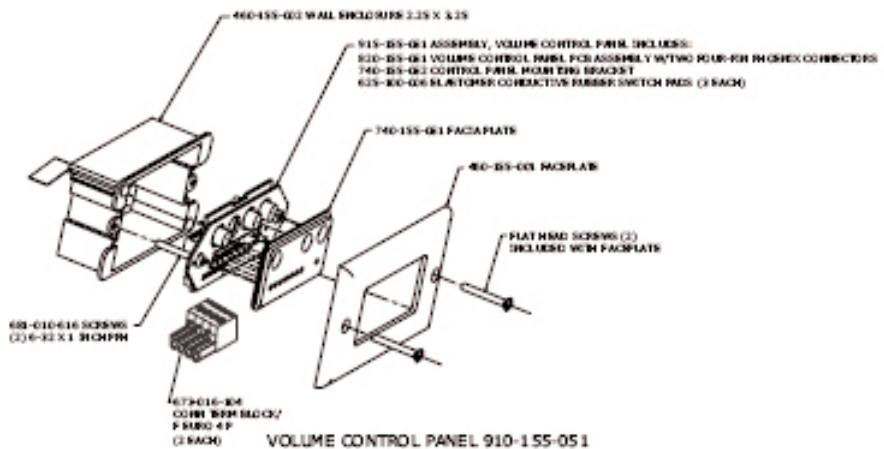
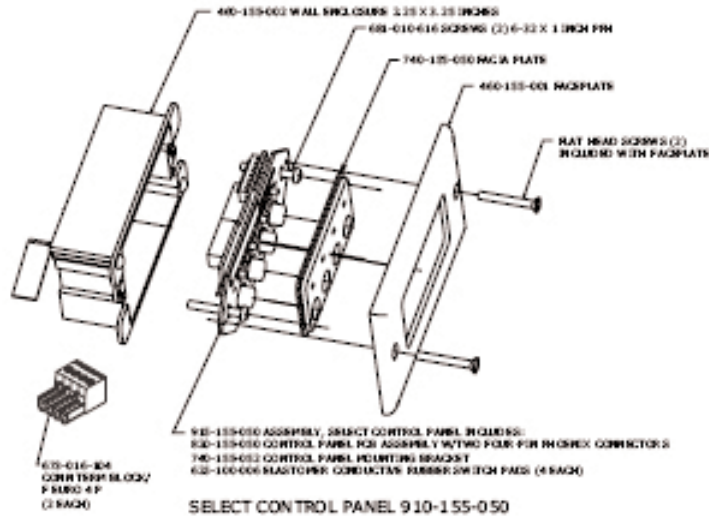

## > CLEARONE LOCATIONS

**Headquarters:**  
Salt Lake City, UT USA  
5225 Wiley Post Way  
Salt Lake City, UT 84116  
Tel: 801-975-7200;  
800-945-7730  
Fax: 801-977-0087  
sales@clearone.com

**Latin America**  
Tel: 801-974-3621  
global@clearone.com

**EMEA**  
Tel: 44 (0) 1189 036 053  
global@clearone.com

**APAC**  
Tel: 801-303-3388  
global@clearone.com