

ClearOne
You're Virtually ThereSM



Titan™ Monitor Cart

FURNITURE

The Titan™ Monitor Cart features a universal base with choice of dual or single monitor support top and provides superior strength, mobility, and storage space.

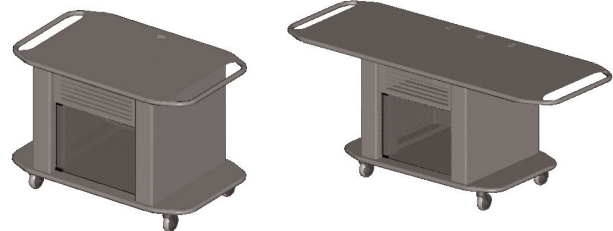

DESIGNED FOR STRENGTH AND MOBILITY

The Titan Monitor Cart is the perfect blend of heavy duty construction and professional styling, resulting in a durable metal cart that is an attractive and highly functional addition to any conferencing environment. With 12- and 14-gauge steel support tops and scratch-resistant coating, the Titan Monitor Cart is built to handle rigorous use and withstand the wear and tear that can quickly make low-quality carts unusable.

At 32" high, the Titan cart allows for easy monitor viewing from virtually any seat in the conferencing room. And the generous storage space accommodates multiple pieces of equipment, making the Titan cart a self-contained conferencing unit that can easily be moved to different meeting rooms.

The Titan cart provides many extras that facilitate product installation including a removable vented back panel with a cable management duct, a 9-space rack with 22" depth, a 2" rack-rail recess behind the door to ensure adequate space for equipment clearance, and a 7 ½" shelf with removable vented front panel for a center-channel speaker or VCR/DVD player.

SUPERIOR METAL CONSTRUCTION

The Titan Monitor Cart features steel construction for strength and durability—supporting up to 800 lb (364 kg).

VERSATILE

The modular design makes it easy to switch between the dual or single top for upgrades or changing room requirements.

HIGHLY MOBILE

With precision-synthetic, double ball bearing casters and 5½" clearance, the monitor cart is extremely easy to maneuver from room to room.

PROFESSIONAL STORAGE

The Titan Monitor Cart design provides a professional-grade rack-rail system with cable management pathways to easily accommodate all types of equipment.

PRODUCT APPLICATIONS

The mobility of the Titan Monitor Cart makes it ideal for corporate or educational facilities where resources are often shared among multiple rooms. The single monitor support top easily holds up to a 36" WEGA® monitor and is a perfect addition to small conference rooms or executive offices. The dual monitor support top holds up to two 32" WEGA monitors or up to two 36" standard monitors and can be used to provide dual monitor display for video-conferencing in training rooms and distance learning centers.

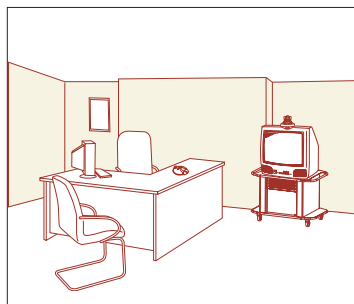

The Titan Monitor Cart provides convenient storage for all conferencing equipment.

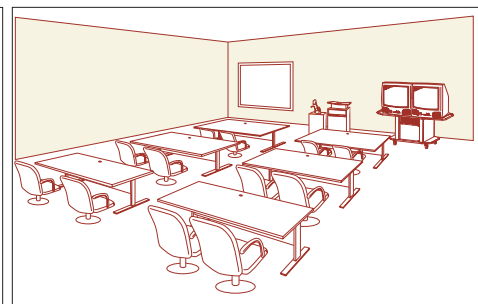

The dual monitor support top is ideal for training rooms and distance learning centers where dual display is desirable.

Titan Monitor Cart

ADVANCED PRODUCT FEATURES

- 32" height for easy viewing in conferencing rooms
- 9-space integrated rack-rail system
- 22" rack depth supports professional depth equipment
- Rack rails recessed 2" behind door to ensure adequate clearance for equipment
- Dynamic air-flow construction promotes air flow to provide cooling to rack-mounted equipment
- 7 ½" shelf with removable vented panel for center-channel speaker or VCR/DVD player
- Smoked acrylic front door with lock for security
- Rubber grommet in rack floor protects cables and provides cable management pass-through
- Single top supports up to a 36" monitor with side-firing audio (Sony WEGA)
- Dual top supports up to two 32" monitors with side-firing audio (Sony WEGA) or two standard 36" monitors
- Wider and deeper tops that completely support monitors—eliminating overhang and covered handles

PRODUCT DIAGRAM

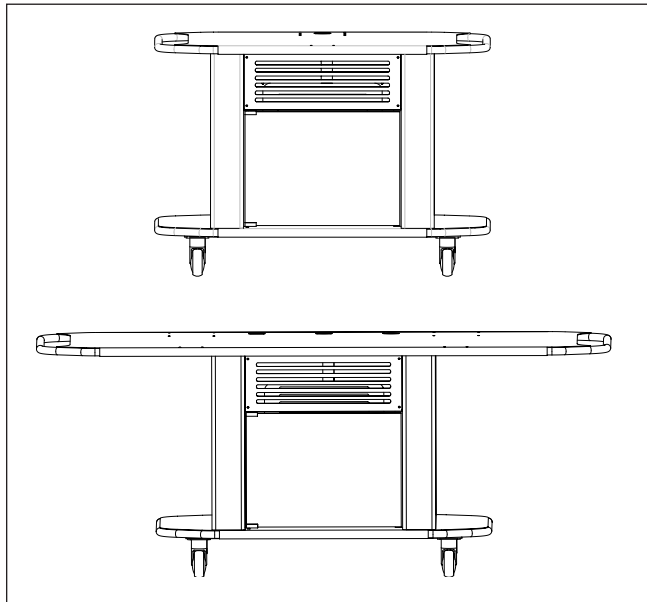

MODULAR DESIGN

The Titan Monitor Cart consists of a universal base and a separate top section. The top section is available in dual or single monitor sizes and either can easily be attached to the universal base. The single monitor top features a single grommet for cable management while the dual monitor top features three grommets.

PRODUCT SPECIFICATIONS

DIMENSIONS (W x H x D)

- Single top option: 39" x 32" x 28"
(99.1 x 81.3 x 71.1 cm)
With handles: 47" W (119.4 cm)
- Dual top option: 70" x 32" x 28"
(177.8 x 81.3 x 71.1 cm)
With handles: 78" W (198.1 cm)
- Universal base: 30" x 23.5" x 28"
(76.2 x 60 x 71.1 cm)

INTEGRATED RACK

- Height: 9 space, 15.75" (40 cm)
- Depth: 22"
- Rack rails: included
- Rail recess: 2" clearance from door

CASTERS

- Heavy duty (250 lb rating each)
- 5 ½" clearance with 4" diameter

CASTER COMPOSITION

- Precision synthetic, plate-mounted, double ball bearing, with swivel head and rubber tread

VENTED BACK PANEL

- Height: 17"
- Width: 17"
- Attachment: Four #8-32 screws

WEIGHT CAPACITY

- 800 lb (364 kg)

CONSTRUCTION

- 14-, 12-, and 11-gauge steel
- Columnar support, channel welded

MONITOR SUPPORT

- Single: Up to 36" WEGA monitor with side-firing audio
- Dual: Up to two 32" WEGA monitors with side-firing audio or two 36" standard monitors

PART NUMBERS

- 911-300-020 Universal base
- 911-300-021 Single support top
- 911-300-022 Dual support top