



PRO AV | HOME ENTERTAINMENT



MOUNTING SOLUTIONS PRODUCT GUIDE

- Projector Mounts | Accessories
- Large Flat Panel Mounts | Accessories
- Medium Flat Panel Mounts | Accessories
- Small Flat Panel Mounts | Accessories
- Lifts | Accessories
- TV Mounts | Accessories

www.chiefmfg.com

SEPTEMBER 2005

end-user focused | faster installation | proven quality | superior service

CHIEF



AWARDS

Chief's PG-1™ Projector Guard was a 2004 Awards Portfolio Winner for Media & Methods magazine, recognizing Chief's significant contribution to the school market. A top security solution for schools and gymnasiums, PG-1A fully encloses projectors in a locked steel cage to prevent theft, as well as recreational damage.

Chief also won the Best of NeoCon Gold Award for the FWG-110™ Height-Adjustable Dual Arm Wall Mount and the FCG-110™ Height-Adjustable Dual Arm Desk Mount. The award recognizes innovative contributions of companies at the forefront of commercial furnishings. These products also won awards through IIDEX and ADEX.

INNOVATIVE DESIGN

Chief's mounting solutions are designed to support a wide range of audio/visual applications including **corporate boardrooms, training facilities, home theaters, educational institutions, digital signage, entertainment venues, trade show exhibits and office furniture systems.** Chief prides itself on offering quality custom and universal products and innovative designs that are strong, functional and easy to install. Chief's dedicated engineering team is progressively developing cutting-edge mounting options to meet your needs.

EXPERT CUSTOMER SERVICE

Chief products are backed by an expertly trained Customer Service group dedicated to responding to your needs. At Chief, helping customers is our priority and we are here to answer all of your mounting and installation questions.



SERVICE TRAINING

Every employee at Chief goes through an extensive product training program so they are able to provide knowledgeable, educated support to meet your needs.

CERTIFICATION

Chief is a Certified Audio Visual Solutions Provider (CAVSP) and has achieved a published level of certification among our staff to maintain a standard of excellence in the AV industry.

CHIEF AT A GLANCE

MORE THAN JUST PRODUCTS!

End-User Focused

Product features that enhance the user AV experience.

Faster Installation

Chief adds value by saving installers and dealers time with product features, product breadth, comprehensive collateral as well as consistently shipping a complete solution on time.

Superior Support

Expert personal sales and technical service and support, on-time and rapid shipment and delivery; and comprehensive online information.

Proven Quality

27 years of engineering mounting solutions, UL rated and seismic testing, and solid steel construction.

COMMUNICATION TOOLS

Product Literature

Chief's 2005 Full-Line Product Guide and product specific flyers provide you with all the information you need to select the right solutions for your mounting applications.

www.chiefmfg.com

Chief's website provides complete product and technical information, drawings, photos, specifications, new products, literature downloads, trade show dates, and up-to-the-minute cross-reference information. Look for a fresh, new Chief website in 2006, which will include a new look and added functionality, while still maintaining all of the great search features you currently use.

E-Bulletins

Choose from five different E-bulletins to directly receive the latest new product and company information via email: ProAV, Home Entertainment/Residential, Office/Workstation, International and the Cross-Reference Update. Visit www.chiefmfg.com to sign up.

ONLINE INDUSTRY RESOURCES

Sweets Directory

Chief's partnership with McGraw Hill Construction Sweets enables you to access Chief product information tailored to the needs of: architects, engineers and contractors; facility managers; and residential customers. See Chief at www.sweets.com.

InfoComm iQ

Find Chief product information on InfoComm iQ, an industry-wide audio/visual product catalog database of ICIA. Connect to www.infocomm.org/iQ to access Chief's product information.

D-Tools

Chief has partnered with D-Tools, an online software tool, to enable installers and integrators to build and design room specifications online at www.d-tools.com.

CONTACT US

CUSTOMER SERVICE

Monday–Friday from
7 am–7 pm (CST) to answer
questions and provide
assistance.

USA

8401 Eagle Creek
Parkway, Ste. 700
Savage, MN 55378 USA

■ P 800.582.6480 /
952.894.6280

■ F 877.894.6918 /
952.894.6918

■ www.chiefmfg.com

■ chief@chiefmfg.com

EUROPE/ INTERNATIONAL

Zekeringstraat 17
1014 BM Amsterdam
Netherlands

■ P 31 020 5708923

■ F 31 020 5708989

■ europe@chiefmfg.com

PROFESSIONAL AFFILIATIONS

■ AIA

■ CEA

■ CEDIA

■ HES

■ HTSA

■ ICIA

■ NAB

■ NSCA







■ PARA

NAVIGATING THE CHIEF PRODUCT GUIDE

The Chief product guide is now easier than ever to navigate. Find exactly what you need by using the color-coded boxes at the top of each section.

Chief has also made it easy to identify key product features by using icons to call out new and home entertainment products. All mounts and accessories that are UL Listed or Seismic Rated are also identified.

Sections are color-coded for quick reference.

-  Projectors & Accessories
-  Large Flat Panel & Accessories, Screen sizes 40-65"
-  Medium Flat Panel & Accessories, Screen sizes 26-40"
-  Small Flat Panel & Accessories, Screen sizes 10-26"
-  Lifts & Accessories
-  CRT TV Mounts & Accessories

Use the following icons throughout the catalog to assist in product selection.

 New Product Offering

 UL Listed*

 Seismic Rated

 Home Entertainment Collection

* This product has been evaluated and listed by the Underwriters Laboratories Inc. and meets all applicable safety standards.

MESSAGE FROM THE PRESIDENT

Chief is committed to providing you the industry's broadest range of installer-friendly, innovative products backed by 27 years of proven product quality and superior customer service.

We sincerely thank you for your ongoing support, and look forward to many more years serving your business needs with our full line of mounting solutions and accessories.

– Scott Gill,
President and CEO

WHAT'S NEW?

Chief has over 20 new products launching in 2005. Here's an overview of what you can expect to see:

- Expanded screen size capability to include medium (26-40") screens
- FUSION™ Fixed and Tilt Wall Mounts for Medium and Large Flat Panel
- REACTION™ Swing Arm Mounts for Medium and Large and Flat Panel
- CYNERGY™ Swing Arm Mounts for Medium and Small Flat Panel
- RPA-U™ Projector Mount Color Options
- PSB-U™ Universal Interface
- Expanded Security Accessories including PL-1™ Projector Lock



TABLE OF CONTENTS

2005 PRODUCT GUIDE

INTRODUCTION1-2
TABLE OF CONTENTS3
PRODUCT DESIGN OVERVIEW4-5

PROJECTOR

Product Overview6-9
INVERTED MODELS
 RPA Custom Mount10-11
 RPA-U Universal Mount12-13
NON-INVERTED MODELS
 UPC Custom Mount14
 LCDA Universal Mount15
HEAVY-DUTY INVERTED MODELS
 VCM Custom Mount16
STACKERS
 LCD Stacker17
 Micro-Set & Adjusta-Set Stackers18
SECURITY
 PL-1 Projector Lock20
 PG-1A/PG-2A Projector Guards21
ACCESSORIES20-27

LARGE FLAT PANEL

26" – 65" Screens

Product Overview28-31
WALL MOUNTS
 PSM Fixed Mount32
 PST Tilt Mount33
 PRO Lockable Tilt Mount34
 PLP Pull-N-Tilt™ Mount35
 PWR Single Swing Arm Mount36
 PNR Dual Swing Arm Mount37
 PDR Dual Swing Arm Mount38
CEILING MOUNTS
 PCM Single Ceiling Mount40
 PDC Dual Ceiling Mount41
TRUSS & POLE MOUNTS
 TPS Fixed Mount42
 TPM/TPP Tilt-Adjustable Mounts43
STANDS & CARTS
 PSS/PTS Table Stands44
 PFS Floor Stand45
 PFB Dual Pole Floor Stand46
 PTC Mobile Cart47
 PPC/PPD Presenters Carts48
ACCESSORIES50-54

MEDIUM FLAT PANEL

26" – 40" Screens

WALL MOUNTS
 MSR Fixed Mount60
 MTR Tilt Mount61

MWR/MWH Single Swing Arm
 Mounts62
 JWP/JWS/JWD Pivot/Tilt Mounts63

CEILING MOUNTS

MCS/MCD Single and
 Dual Ceiling Mounts64
ACCESSORIES66-67

SMALL FLAT PANEL

10" – 40" Screens

Product Overview56-59
Q2 TECHNOLOGY

Wall Mounts

FSM/FPM Fixed & Tilt Mounts72

Pole Mounts

FSP/FDP Single & Dual Display
 Pole Mounts73

CENTRIS TECHNOLOGY

Wall Mounts

FWP/FWS/FWD Pivot/Tilt Mounts74
 FWV/FWG/FWB Height-Adjustable
 Mounts75

Desk Mounts

FCS/FCD Single & Dual Swing Arm
 Mounts76
 FCV/FCG/FCB Height-Adjustable
 Swing Arm Mounts77

Pole Mounts

FPP/FPS/FPD Pivot/Tilt Mounts78

Ceiling Mounts

FHP Ceiling Mount79

ARRAY

FSA-220/FSA-320 Single & Dual Arrays ..80

ACCESSORIES82-83

LIFTS

Product Overview84-87

PROJECTOR

SL-150 Smart-Lift®88
 SL-236 Smart-Lift®89

FLAT PANEL

PUL Electric Pop-Up Lift90
 PCL Electric Ceiling Lift91

ACCESSORIES92

TV/MONITOR

Product Overview94

CTV TV Mount95

ACCESSORIES96-97

INDEX100

TERMS AND CONDITIONS101

NEW DESIGNS DRIVE OUR BUSINESS

At Chief, we believe in continuous innovation. Not only are we dedicated to your custom installation needs, we now offer a new series of universal options. In 2005, Chief launched more than 20 new product solutions and accessories, all designed for faster and easier installation. These products are built with the same quality you've come to expect, and include exclusive features that make them truly unique.



PROJECTOR MOUNTS

CUSTOM AND UNIVERSAL SOLUTIONS

- **Ideal For Any Installation**
No matter what the application, Chief has the solution. Choose from
 - Custom
 - Universal (featured right)
 - Non-Inverted
 - Heavy-Duty Non-Inverted
- **Custom & Universal**
Choose RPA for a custom fit – simple to install and service, or RPA-U which includes a universal bracket that fits most projectors on the market.
- **Industry-Leading Features**
Convenient features such as independent roll, pitch and yaw make these mounts state-of-the-art.
- **Quick & Easy Installation**
Faster, hassle-free installations with no assembly required.

RPA-U™ UNIVERSAL PROJECTOR MOUNT

- **Independent Roll, Pitch and Yaw**

For quick and precise image registration.

- **Integrated Cable Management**

Allows cables to feed out of the top of the mount without additional accessories.

- **Quick Projector Connect/Disconnect**

With convenient lamp and filter access, always maintains registration and pre-set adjustments.

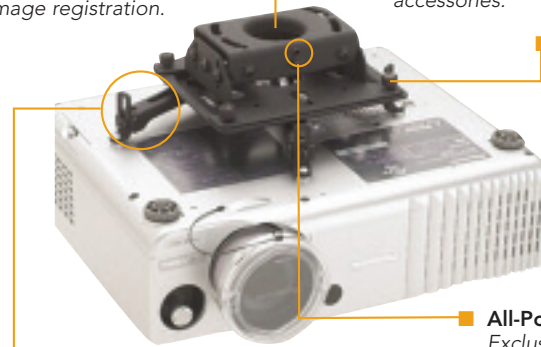

- **Adjustable Mounting Legs and Feet –**

Adjust vertically and horizontally for ultimate flexibility! (RPA-U Only).

- **All-Points™ Security System**

Exclusive locking hardware at all key connection points to protect against theft.

RPA Custom Projector Mount

This popular mount features a custom-designed SLB bracket along with the same great features as the RPA-U. Fast, hassle-free installation makes this mount a perfect choice for when the projector type is known.



LIFTS

PROJECTOR AND TV

- **Smart Lifts® SL-150 and SL-236 Projector Lifts**
 - Easy to use
 - Attractive Installations
 - Exceptionally smooth and quiet,
 - Multiple mounting positions for ceiling tile or unfinished ceilings
- **PUL – Electric Pop-Up Lift**
 - Quiet operation with adjustable travel distance



SL-150



SL-236



PUL

DESIGN OVERVIEW

2005 PRODUCT GUIDE

SWING ARM MOUNTS



■ **Ideal for Small Flat Panel Displays**
Safely secure 10" – 40" TVs and get maximum range of motion.

■ **Centris Technology**
These mounts include Centris™ Technology, which self-adjusts to support different screen sizes and enables effortless fingertip adjustments.

■ **Easy 3-Step Installation**
1. Attach plate to wall
2. Hang mount onto wall
3. Attach screen to mount

10" – 40" TVs

CUSTOM OR UNIVERSAL

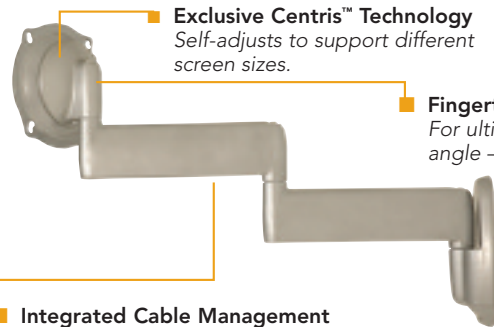

■ **Exclusive Centris™ Technology**
Self-adjusts to support different screen sizes.

■ **Fingertip Tilt and Swivel**
For ultimate viewing at any angle – all without tools.

■ **Clean Installation**
With hidden wall plate hardware.

■ **Integrated Cable Management**
A predefined pathway conceals and protects cables inside the arm.

Note: Desk and height-adjustable models are also available.

FIXED AND TILT WALL MOUNTS



■ **Faster Installation**
Exclusive features, like the Q-Latch™ Mounting System and Rapid Level™ Provides hands-free leveling, reduce installation time.

■ **End-User Focused**
Compatible with multiple accessories to customize any installation.

■ **Universal Option**
When ordered with PSB-U Universal Interface.

26" – 65" TVs

CUSTOM OR UNIVERSAL



■ **Built-in Cable Management**
Expanded wall plate opening provides cable access and reduces risk of outlet interference.

■ **Ultra Low-Profile**
Fits tight against the wall.

■ **Multiple Ordering Options**
Ensures a perfect fit.

■ **Rapid Level™ System**
Provides hands-free leveling of the mount.

■ **Q-Latch™ Mounting System**
Provides quick connect/disconnect of screen.

■ **Integrated Lateral Shift**
For a flexible installation.

SWING ARM MOUNTS



■ **Faster Installation**
Mounting Guide System, post-installation height adjustment and open wall plate simplify installation.

■ **End-User Focused**
Unique design allows extreme range of motion; Patented G-Force™ Gravity-Centered Tilt provides easy fingertip adjustment.

■ **Universal Option**
When ordered with PSB-U Universal Interface.

26" – 65" TVs

CUSTOM OR UNIVERSAL

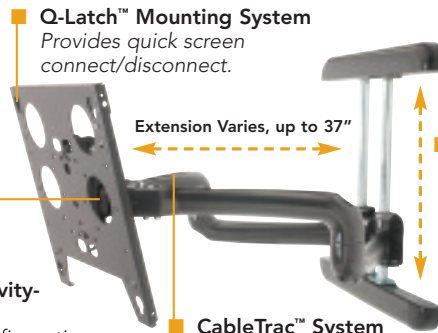

■ **Q-Latch™ Mounting System**
Provides quick screen connect/disconnect.

Extension Varies, up to 37"

■ **Post-Installation Height Adjustment**
For perfect placement (PDR & PNR only).

■ **G-Force™ Gravity-Centered Tilt**
Provides easy fingertip tilt from +5°-15°.

■ **CableTrac™ System**
Channeled cable management for a clean installation.

NEW PSB-U UNIVERSAL INTERFACE

Available for all FUSION and REACTION Mounts, PSB-U can be ordered to create a universal installation. Perfect when stocking mounts is a necessity.





SECTION 1 PROJECTORS—LCD/DLP/CRT



Selecting the right projector mount is as important as choosing the right projector. At Chief Manufacturing, we make mounts that complement and increase the functionality of the projector. Chief mounts are recognized for their independent roll, pitch and yaw adjustments that make installation quick and easy, and the adjustments precise and secure. Chief's projector mounts offer a wide variety of features and benefits that are sure to answer all of your installation needs.

HOW TO CHOOSE A PROJECTOR MOUNT

Choosing the right projector mount ensures the best performance. All Chief Projector Mounts offer industry-leading features:

- Quick installation with easy lamp and filter access
- Fast image registration – independent roll, pitch and yaw allow each adjustment to be tightened or refined separately
- Solid Quick-Disconnect System – easily remove and replace the projector without losing image registration
- Easy maintenance
- UL listed
- Service excellence for all your installation needs
- Quick Shipping – Most Chief mounts ship within 24 hours!

INDUSTRY-LEADING INDEPENDENT ROLL, PITCH & YAW FOR PRECISE IMAGE REGISTRATION

- Roll Adjustment: +/- 4°. Simply loosen screws, adjust mount and tighten to hold adjustment.
- Pitch Adjustment: +/- 25° on each side of the mount. Full range of pitch in a flush mount installation.
- Yaw Adjustment: 360° by turning mount on threaded column. 12° yaw possible when flush mounting.

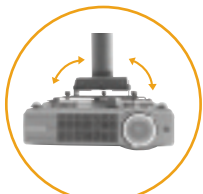

ROLL ADJUSTMENT $\pm 4^\circ$

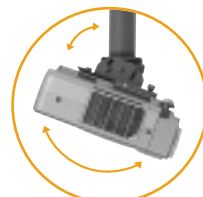

PITCH ADJUSTMENT $\pm 25^\circ$

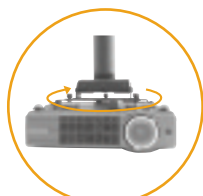

YAW ADJUSTMENT 360°

PROJECTORS



CHIEF ADDS VALUE TO EVERY MOUNT WE MAKE.

End-User Focused

- **Customer-Friendly Designs**
Easy to install and maintain.
- **Independent Roll, Pitch and Yaw**
For quick and precise image registration.
- **Adjustable Mounting Legs and Feet (RPA-U)**
Adjusts horizontally and vertically for maximum flexibility.
- **All-Points™ Security**
Exclusive locking hardware at all key connection points to protect against theft.

Proven Quality

- **Industry Leader**
27 years of engineering excellence.
- **Solid Steel Construction**
Designed with heavy-gauge steel.
- **Custom and Universal Solutions**
Choose from an expansive universal product offering, or utilize Chief's design expertise for a custom fit.

Faster Installation

- **Quick Projector Connect/Disconnect**
Provides convenient lamp and filter access for quick maintenance.
- **Includes Everything You Need**
Quick to install with no additional assembly.

Superior Service

- **Expert and Accessible Customer Service**
 - Knowledgeable support from experienced industry professionals
 - Order tracking to technical issues in one phone call.
- **On-Time Delivery**
Most products ship within 24 hours after receipt of purchase order.
- **Multiple Ordering Options**



Features like adjustable mounting legs and feet on Chief's RPA-U make post-installation adjustments quick and easy.



Heavy-gauge steel reinforces the strength of products like Chief's new PL-1 Projector Lock.



Quick projector disconnect provides convenient lamp and filter access.



Aaron Harris, Chief Customer Service, recommends the best accessories for the installation.

PROJECTOR PRODUCT OVERVIEW

Projector

POPULAR MODELS

CUSTOM

RPA™
Custom Projector Mount

PG 10-11



MAX WEIGHT: 50 lbs **B**

INVERTED MODELS

UNIVERSAL

RPA-U™
Universal Projector Mount

PG 12-13



MAX WEIGHT: 50 lbs **B S W**



NON-INVERTED MODELS

CUSTOM

UPC™
Custom Projector Mount

PG 14



MAX WEIGHT: 50 lbs **B S**

UNIVERSAL

LCDA™
Universal Projector Mount

PG 15

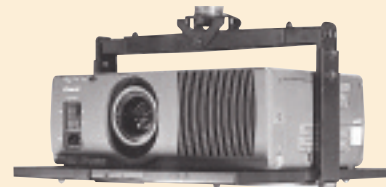

MAX WEIGHT: 50 lbs **B**

INVERTED, HEAVY DUTY MODELS

CUSTOM

VCM™
Custom Projector Mount

PG 16



MAX WEIGHT: 250 lbs **B**

LCD™ Series projector stackers and slide stackers available on page 17-18.
See pages 20-27 for a complete list of projector accessories.



PROJECTOR CEILING MOUNTS

CUSTOM SOLUTION

RPA™ SERIES INVERTED CUSTOM PROJECTOR MOUNT

This top-selling, custom projector mount with quick installation and low-profile design is perfect for offices, schools and homes.



FEATURING

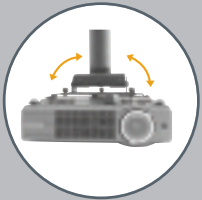

ROLL ADJUSTMENT: $\pm 4^\circ$

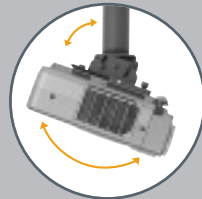

PITCH ADJUSTMENT: $\pm 25^\circ$

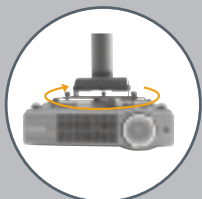

YAW ADJUSTMENT: 360°

MOUNTING OPTIONS

1. Flush mount to ceilings using the four corner slots in the top of the mount. Suitable access is provided to allow flush mounting without disassembly.
2. 1/4" Threaded Rod using the four corner slots in the top of the mount.
3. 1-1/2" NPT Threaded Extension Column using the threaded opening at the top of the mount.

Note: Threaded Extension Column and Threaded Rod not included.

SPECIFICATIONS

Model:	RPA
Roll	$\pm 4^\circ$
Pitch	$\pm 25^\circ$
Yaw	360°
Dimensions*	6-1/4" x 1-3/4" x 5-1/2"
WxHxD	(159 x 44 x 140 mm)
Color	Black
Weight	
Capacity	50 lbs (22.7 kg)

* Height doesn't include interface bracket

- Integrated Cable Management**
 Allows routing of cables through top of the mount without additional accessories.
- Independent Roll, Pitch and Yaw**
 For quick and precise image registration.
- Custom-Designed SLB Bracket**
 Includes an SLB bracket designed for each specific projector.
- Quick & easy installation with no assembly required!**
- Quick Projector Connect/Disconnect**
 With convenient lamp and filter access on most projectors.
 - Always maintains registration
 - Disconnecting doesn't affect pre-set adjustments
- All-Points™ Security System**
 Exclusive locking hardware at all key connection points to protect against theft.
 - Steel-into-steel design is more effective than other security systems
 - Included at no additional cost!
 - For additional RPA security, see the security accessories on pages 20-21
- Compatible with many accessories for all your installation needs.**
 - Easily replace filter or bulb on most projectors
 - Allows proper ventilation
 - Fits the contour of the projector for the lowest profile possible!

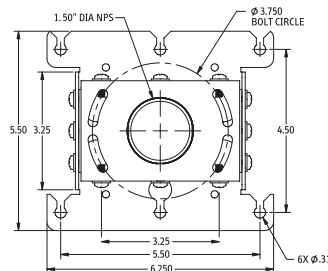

Top View

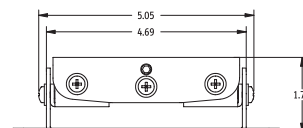

Front View:
Add 3/4" (19 mm) for most interface brackets



PROJECTOR CEILING MOUNTS

COMMON INSTALLATIONS AND ACCESSORIES



- **CMA-440 Lightweight Suspended Ceiling Kit**
 - A flexible solution for mounting projectors from a suspended ceiling
 - Mount above an existing ceiling tile (ceiling tile not shown)
 - Safety cable and hardware included
 - Weight Capacity: 50 lbs (22.7 kg)

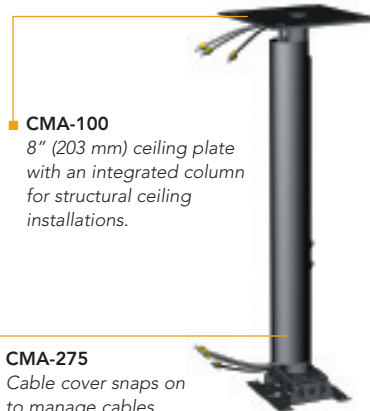

■ **CMA-100**
8" (203 mm) ceiling plate with an integrated column for structural ceiling installations.

■ **CMA-275**
Cable cover snaps on to manage cables, providing a clean look!

POPULAR PRODUCT

Get the Next Level in Projector Security with the PL-1 Projector Lock!

- Provides an added level of security with multiple locking options
- Easily integrates into new or existing RPA installations
- Ships fully assembled
- Convenient lamp and filter access with a slotted design for projector ventilation
- Sliding doors for easy projector access
- Great for professional applications, schools and gymnasiums



RECOMMENDED ACCESSORIES

RPA	PAGE
CMA-100 8" (203 mm) Ceiling Plate with Attached Adjustable 1-1/2" NPT Column	22
CMA-110 8" (203 mm) Ceiling Plate with 1-1/2" NPT Opening	22
CMA-115 6" (152 mm) Ceiling Plate with 1-1/2" NPT Opening	22
CMA-152 1-1/2" to 1-1/2" NPT Coupler with Cable Access	26
CMA-330 Offset Ceiling Plate	22
CMA-347 Projector Vibration Isolator	26
CMA-372 Offset Unistrut Adapter	25
CMA-440 Lightweight Suspended Ceiling Kit	23
CMA-450 Suspended Ceiling Kit	23
CMA-455 Suspended Ceiling Replacement Kit	23
CMA Fixed and Adjustable Extension Columns	24
LSB-100 Lateral Shift Bracket	24
PG-1A or PG-2A Projector Guards	21
PL-1 Projector Lock	20
WMA-300 Wall Mount Arm	25

FAQ

1. How do I know which mount to order?

A Chief's cross-reference chart will help determine which mount to order based on the projector model.

2. Do I need to order a separate bracket?

A The RPA ships complete with an SLB bracket.

3. How much assembly is required?

A None, just attach the mount to the provided bracket.

4. How much weight does the mount hold?

A Each mount is designed to support the weight of the projector model(s) specified. However, your ceiling must hold at least five times the weight of your installation.

5. How much height will the mount add to my installation?

A The RPA adds approximately 2-1/2" (64 mm).

6. Do I need additional accessories for my installation?

A For flush mounting, no additional accessories are needed. Often you will need to lower your projector from a structural, suspended or finished ceiling. For these common applications, you will want to order the appropriate accessories.

7. If I use the RPA with a Suspended Ceiling Kit, do I need an extension column?

A Yes. Any 1-1/2" NPT Threaded Extension Column will work with Chief's Suspended Ceiling Kits.

HOW TO ORDER

1. Determine which mount to order by looking in the cross-reference chart. For the most recent cross-reference chart, visit www.chiefmfg.com or call Customer Service at 1.800.582.6480 (domestic) or 952.894.6280 (international).
2. Choose any appropriate accessories needed for your installation.
3. Fax or e-mail your order to Customer Service at 877.894.6918 (domestic) or 952.894.6918 (international), or orders@chiefmfg.com.



PROJECTOR CEILING MOUNTS

UNIVERSAL SOLUTION

RPA-U™ INVERTED UNIVERSAL PROJECTOR MOUNT

A universal, low-profile mounting solution with custom features. It's perfect for stocking dealers or unplanned installations where the projector type is unknown.



Universally Supports Most Inverted Projectors

NEW Now available in Black, White and Silver!



RPA-UW

RPA-US

Universal Bracket (SLB-U)

Ships complete with a universal bracket to fit most inverted projectors on the market.

Independent Roll, Pitch and Yaw

For quick and precise image registration.

Includes everything you need for a quick installation. No assembly required!

Integrated Cable Management

Allows routing of cables through top of mount without additional accessories.

Solid Steel Design

For secure mounting.

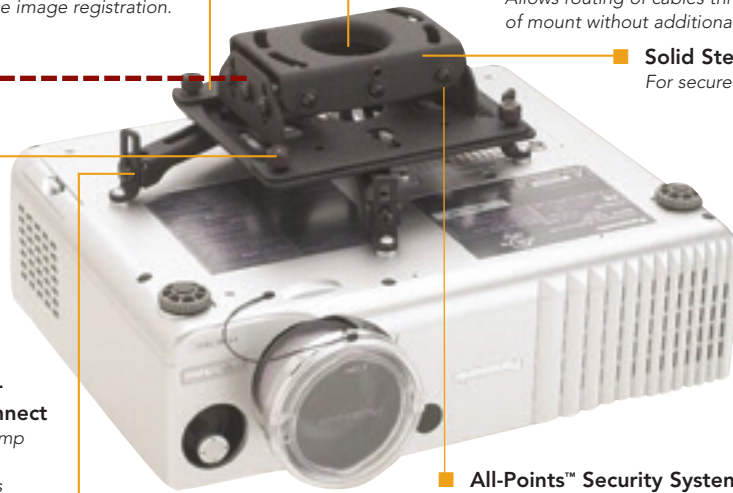

Quick Projector Connect/Disconnect

with convenient lamp and filter access.

- Always maintains registration
- Disconnecting doesn't affect pre-set adjustments

PRODUCT FEATURE:

Adjustable mounting legs and feet

- Easy to install
- Adjusts horizontally and vertically for unmatched flexibility!
- Vertically height-adjustable, even after installation

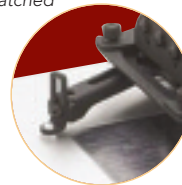

All-Points™ Security System

Exclusive locking hardware at all key connection points to protect against theft.



Compatible with many accessories for all your installation needs.

FEATURING

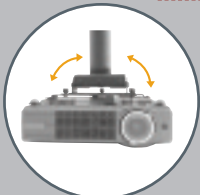

ROLL ADJUSTMENT: +/-4°

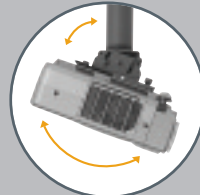

PITCH ADJUSTMENT: +/-25°

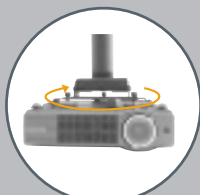

YAW ADJUSTMENT: 360°

MOUNTING OPTIONS

1. Flush mount to ceilings using the four corner slots in the top of the mount. Suitable access is provided to allow flush mounting without disassembly.
2. 1/4" Threaded Rod using the four corner slots in the top of the mount.
3. 1-1/2" NPT Threaded Extension Column using the threaded opening at the top of the mount.

Note: Threaded Extension Column and Threaded Rod not included.

SPECIFICATIONS

Model:	RPA-U
Roll	+/-4°
Pitch	+/-25°
Yaw	360°
Dimensions WxHxD	6-1/4"x2-1/2"x5-1/2" (159 x 64 x 140 mm)
Color	Black/Silver/White
Weight Capacity	50 lbs (22.7 kg)

POPULAR PRODUCT

Make ceiling installation quick and easy with the CMA-100™ Ceiling Plate with Attached Adjustable Length Column!

- Includes everything but the mounting hardware to mount your projector from the ceiling!
- A universal solution for most structural ceiling installations
- Allows you to quickly achieve the correct drop distance
- 1-1/2" NPT threaded column attaches to Chief accessories



PROJECTOR CEILING MOUNTS

FAQ

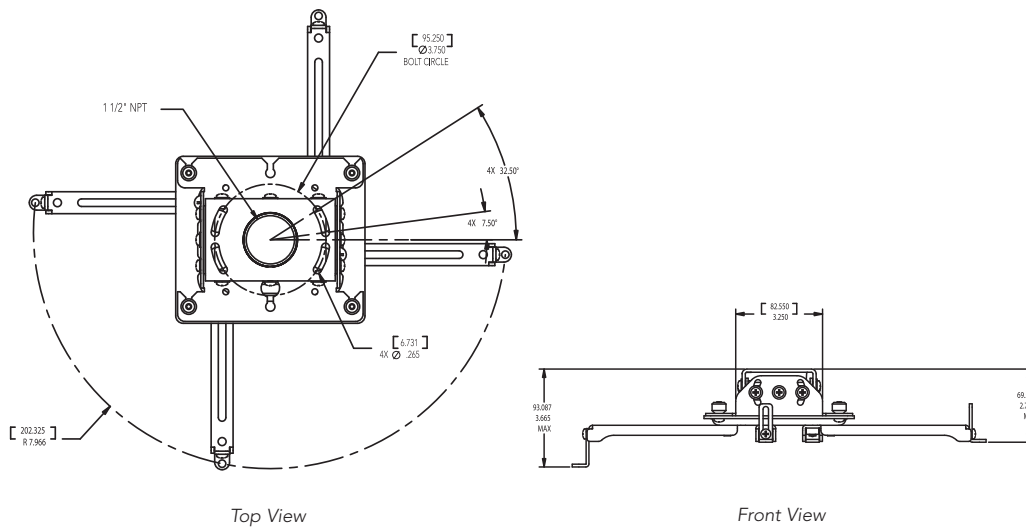

POPULAR ACCESSORIES



PL-1
Projector Lock



CMA-012
Extension Column



CMA-101
Designer Ceiling Plate



CMA-100
Ceiling plate with column

RECOMMENDED ACCESSORIES

RPA-U

	PAGE
CMA-100 8" (203 mm) Ceiling Plate with Attached Adjustable 1-1/2" NPT Column	22
CMA-101 Designer Ceiling Plate	22
CMA-110 8" (203 mm) Ceiling Plate with 1-1/2" NPT Opening	22
CMA-115 6" (152 mm) Ceiling Plate with 1-1/2" NPT Opening	22
CMA-152 1-1/2" to 1-1/2" NPT Coupler with Cable Access	26
CMA-330 Offset Ceiling Plate	22
CMA-347 Projector Vibration Isolator	26
CMA-372 Offset Unistrut Adapter	25
CMA-440 Lightweight Suspended Ceiling Kit	23
CMA-450 Suspended Ceiling Kit	23
CMA-455 Suspended Ceiling Replacement Kit	23
CMA Fixed and Adjustable Extension Columns	24
LSB-100 Lateral Shift Bracket	24
PG-1A or PG-2A Projector Guards	21
PL-1 Projector Lock	20
WMA-300 Wall Mount Arm	25

1. How do I know which mount to order?

A Chief's RPA-U is a universal mounting solution and supports most projector models.

2. Do I need to order a separate bracket?

A The RPA-U ships complete with an SLB-U bracket.

3. How much assembly is required?

A None, just attach the mount to the provided bracket.

4. How much weight does the mount hold?

A The RPA-U is designed to support up to 50 lbs (22.7 kg).

5. How much height will the mount add to my installation?

A The RPA-U adds approximately 2-1/2" (64 mm).

6. Do I need additional accessories for my installation?

A For flush mounting, no additional accessories are needed. Often you will need to lower your projector from a structural, suspended or finished ceiling. For these common applications, you will want to order the appropriate accessories.

7. If I use the RPA-U with a Suspended Ceiling Kit, do I need an extension column?

A Yes. Any 1-1/2" NPT Threaded Extension Column will work with Chief's Suspended Ceiling Kits.

8. How do I order an RPA-U in white or silver?

Simply add a "W" for white or an "S" for silver to the end of the part number (ie: RPA-US).

HOW TO ORDER

1. Determine if the RPA-U will work with your projector by examining the technical drawings, or call Customer Service at 1.800.582.6480 (domestic) or 952.894.6280 (international).

2. Choose any appropriate accessories needed for your installation.

3. Fax or e-mail your order to Customer Service at 877.894.6918 (domestic) or 952.894.6918 (international), or orders@chiefmfg.com.



PROJECTOR CEILING MOUNTS

FAQ

1. How do I know if I need a UPC mount instead of an RPA?

A Chief's cross-reference chart identifies non-inverted projectors requiring a UPC mount.

2. How much assembly is required?

A None, just attach the mount to the provided bracket.

3. How much height will the mount add to my installation?

A The UPC adds approximately 1-3/4"-2" (44-51 mm).

4. Do I need additional accessories for my installation?

A For flush mounting, no additional accessories are needed. Often you will need to lower your projector from a structural, suspended or finished ceiling. For these common applications, you will want to order the appropriate accessories.

5. How much weight does the mount hold?

A Each mount is designed to support the weight of the projector model(s) specified. However, your ceiling must hold at least five times the weight of your installation.

HOW TO ORDER

1. Determine which mount to order by looking in the cross-reference chart. For the most recent cross-reference chart, visit www.chiefmfg.com or call Customer Service at 1.800.582.6480 (domestic) or 952.894.6280 (international).

2. Choose any appropriate accessories needed for your application.

3. Fax or e-mail your order to Customer Service at 877.894.6918 (domestic) or 952.894.6918 (international), or orders@chiefmfg.com.

CUSTOM SOLUTION

UPC™ NON-INVERTED PROJECTOR MOUNT

A low-profile solution for projectors that need to be mounted upright in the ceiling.

- Custom Solution**
 Custom-designed brackets fit the contour of the projector for easy installation.
 - Easy lamp and filter access
 - Saves valuable installation time!
- Quick Projector Connect/Disconnect**
 With convenient lamp and filter access.
 - Always maintains registration
 - Disconnecting doesn't affect pre-set adjustments
- Heavy-Duty Steel Construction**
 For added strength and security.
- Integrated Cable Management**
 Allows routing of cables through the top of the mount (column not included).
- Independent Roll, Pitch & Yaw**
 Easy adjustments for precise image registration.
- Choose from a variety of accessories to accommodate all of your installations.**

3 Mounting Options:

1. Flush mount to ceilings using the four corner slots in the top of the mount.
2. 1/4" Threaded Rod using the four corner slots in the top of the mount.
3. 1-1/2" NPT Threaded Extension Column using the threaded opening at the top of the mount.

Note: Threaded Rod and Extension Column not included.

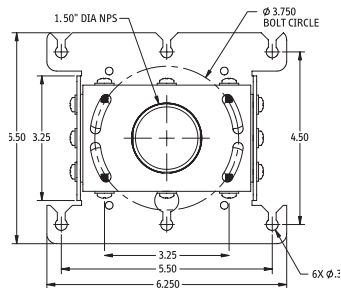

Top View

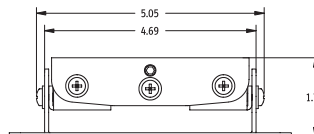

Front View

SPECIFICATIONS

Model:	UPC
Roll	+/-4°
Pitch	+/-25°
Yaw	360°
Dimensions	6-1/4"x1-3/4"x5-1/2"
WxHxD*	(159 x 44 x 140 mm)
Color	Black
Weight	
Capacity	50 lbs (22.7 kg)

*Varies by model.

RECOMMENDED ACCESSORIES

	PAGE
CMA-100 8" (203 mm) Ceiling Plate with Attached Adjustable 1-1/2" NPT Column	22
CMA-110 8" (203 mm) Ceiling Plate with 1-1/2" NPT Opening	22
CMA-330 Offset Ceiling Plate	22
CMA-440 Lightweight Suspended Ceiling Kit	23
CMA Fixed and Adjustable Extension Columns	24
LSB-100 Lateral Shift Bracket	24

PROJECTOR CEILING MOUNTS

CUSTOM SOLUTION

LCDA™ NON-INVERTED UNIVERSAL PROJECTOR MOUNT

Great for portable projector installations in offices and small businesses where the projector needs to be taken down frequently.



LCDA Model	A - Max Height	B - Max Width	C - Tray Depth
LCDA-215C	3-1/3"–4-2/5" (84–112 mm)	7-5/8"–12-3/5" (194–320 mm)	8" (203 mm)
LCDA-220C	7-11/16"–13-2/5" (196–340 mm)	8-5/8"–11-1/2" (219–292 mm)	17-3/4" (450 mm)
LCDA-225C	10-4/5"–16" (274–419 mm)	8-5/8"–11-1/2" (219–292 mm)	17-3/4" (450 mm)
LCDA-230C	7-11/16"–13-2/5" (196–340 mm)	12-11/16"–23-1/4" (324 mm–59.1 cm)	17-3/4" (450 mm)
LCDA-240C	10-4/5"–16" (274–419 mm)	*14-1/8"–19-3/5" (358–498 mm)	22-1/4" (56.5 cm)

*Tray width of LCDA-240C is not adjustable. Adjustments are for the side panels only. Tray is a fixed 12-1/2" (317 mm) wide.

3 Mounting Options:

1. Flush mount to ceilings with the CMA-250 Accessory.
 2. 1/4" Threaded Rod using the four corner slots in the top of the mount.
 3. 1-1/2" NPT Threaded Extension Column using the threaded opening at the top of the mount.
- Note: CMA-250, Threaded Rod and Extension Column not included.

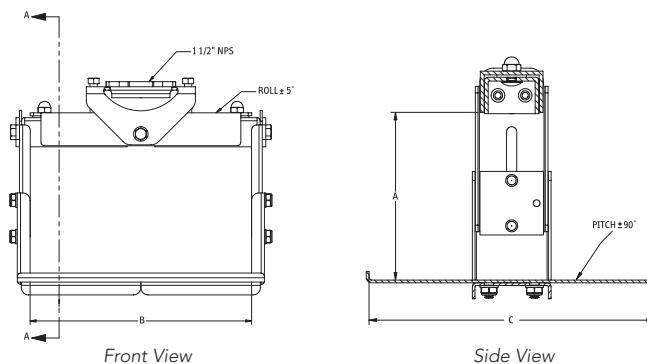

RECOMMENDED ACCESSORIES

PAGE

CMA-100 8" (203 mm) Ceiling Plate with Attached Adjustable 1-1/2" NPT Column	22
CMA-110 8" (203 mm) Ceiling Plate with 1-1/2" NPT Opening	22
CMA-250 Flush Mount Adapter	24
CMA-330 Offset Ceiling Plate	22
CMA-440 Lightweight Suspended Ceiling Kit	23
CMA Fixed and Adjustable Extension Columns	24

SPECIFICATIONS

Model:	LCDA
Roll	+/-5°
Pitch	+/-90°
Yaw	360°
Color	Black
Weight	
Capacity	50 lbs (22.7 kg)

FAQ

1. How do I know which projectors will work with the LCDA Series?

- A** The LCDA Series can be used with any projector that will fit within the maximum equipment size (reference the dimensions chart and diagrams).

2. How do I know which LCDA mount to select?

- A** Verify that your projector can be non-inverted. Find the model with the maximum equipment dimensions that best fits your projector.

3. Do I need to order a separate interface bracket?

- A** No projector bracket is needed with the LCDA Series. The projector rests on a tray and the mount adjusts around it for a secure fit.

4. How much weight does the mount hold?

- A** Each mount is designed to support 50 lbs (22.7 kg). However, your ceiling must hold at least five times the weight of your installation.

HOW TO ORDER

1. Determine which model best fits the dimensions of your projector in height, width and tray depth, or call Customer Service at 1.800.582.6480 (domestic) or 952.894.6280 (international).
2. Choose any appropriate accessories needed for your application.
3. Fax or e-mail your order to Customer Service at 877.894.6918 (domestic) or 952.894.6918 (international), or orders@chiefmfg.com.



PROJECTOR CEILING MOUNTS

CUSTOM SOLUTION

FAQ

1. How do I know if I need a VCM mount instead of an RPA?

A Chief's cross-reference chart tells you exactly which mount to order for your projector.

2. Do I need to order a separate bracket?

A The VCM ships complete with a universal top and HB bracket.

3. How much height will the mount add to my installation?

A The VCM adds 4" (102 mm) plus the interface bracket.

4. How much weight does the mount hold?

A Each mount is designed to support the weight of the projector model(s) specified. However, your ceiling must hold at least five times the weight of your installation.

5. Do I need additional accessories for my installation?

A Yes, the VCM requires an LPK-1 for flush mounting. Often you will need to lower your projector from a structural, suspended or finished ceiling. For these common applications, you will want to order the appropriate accessories.

HOW TO ORDER

1. Determine which mount to order by looking in the cross-reference chart. For the most recent cross-reference chart, visit www.chiefmfg.com or call Customer Service at 1.800.582.6480 (domestic) or 952.894.6280 (international).

2. Choose any appropriate accessories needed for your application.

3. Fax or e-mail your order to Customer Service at 877.894.6918 (domestic) or 952.894.6918 (international), or orders@chiefmfg.com.

VCM™ INVERTED HEAVY-DUTY PROJECTOR MOUNT

Provides strong support for mounting heavy projectors in schools and auditoriums.

- Built-In Lateral Shift**
1-1/2" (38 mm) forward/back and side/side.
- Quick Projector Connect/Disconnect**
With convenient lamp and filter access.
– Always maintains registration
– Disconnecting doesn't affect pre-set adjustments
- 3 Mounting Options:**
 - Flush mount to suitable ceilings – LPK-1 Low-Profile Mounting Kit required.
 - 1/2" (13 mm) Threaded Rod using the four corner slots in the top of the mount.
 - 1-1/2" NPT Threaded Extension Column using the threaded opening at the top of the mount.

Note: LPK-1, Threaded Rod and Extension Column not included.
- Integrated Cable Management**
- Independent Adjustments**
Exclusive micrometer roll and pitch adjustments are made with the alignment features of the body, enabling you to remove the projector without disturbing alignment.
- Steel-into-Steel Construction**
Heavy-duty design securely mounts large, heavy projectors.

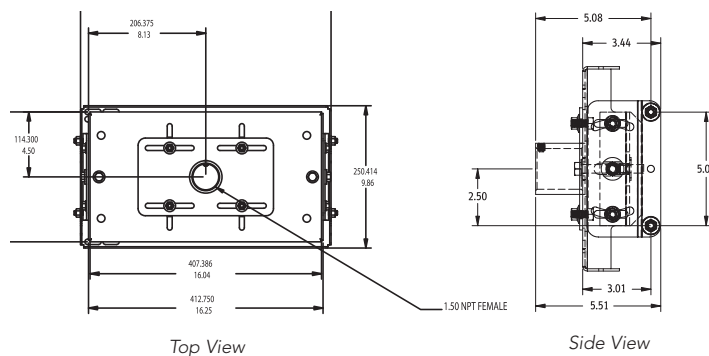

SPECIFICATIONS

Roll	+/-5°
Pitch	+/-20°
Yaw	360°
Color	Black
Weight Capacity	250 lbs (113.6 kg)

RECOMMENDED ACCESSORIES

CMA-100 8" (203 mm) Ceiling Plate with Attached Adjustable 1-1/2" NPT Column	22
CMA-110 8" (203 mm) Ceiling Plate with 1-1/2" NPT Opening	22
CMA-340 Support Bracket and Cable Assembly	26
CMA-450 Suspended Ceiling Kit	23
CMA-455 Suspended Ceiling Replacement Kit	23
LPK-1 Low-Profile Flush Mounting Kit	24
QD-1 Quick-Disconnect	26
XY-1 Heavy-Duty Lateral Shift Bracket	26
CMA Fixed and Adjustable Extension Columns	24

PAGE

PROJECTOR STACKERS

CUSTOM SOLUTION

LCD™ PROJECTOR STACKERS

Stack multiple projectors from the ceiling or tabletop (RPA mounts not included).

HE

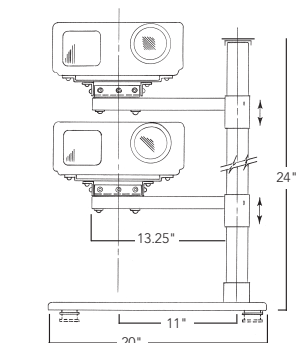
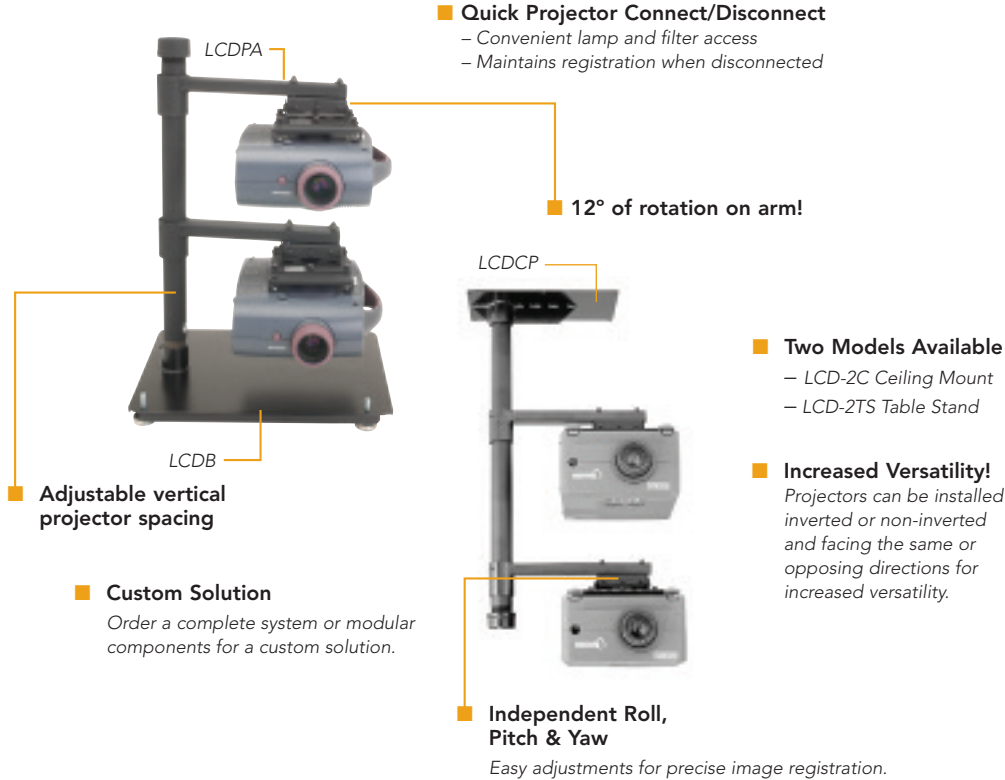

Front View (LCD-2TS Table Stand)

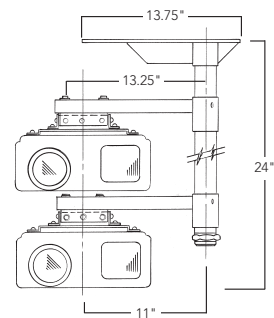

Front View (LCD-2C Ceiling Plate)

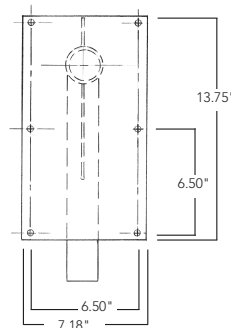

Top View (LCD-2C Ceiling Plate)

FAQ

1. **Do I need to order the projector mount separately?**
A Yes, two RPA or UPC Mounts are required to attach the projectors to the arms.
2. **How much weight does the mount hold?**
A 100 lbs (45.5 kg) maximum support weight. However, your ceiling must hold five times the weight of your installation.
3. **What is the maximum height for the table stand?**
A A 3 ft (0.9 m) extension column is the longest that is recommended, 2 ft (0.6 m) comes standard with the unit.
4. **Can I use Chief's VCM or LCDA Mount with the Stacking System?**
A No, the stacking system is designed to use either RPA or UPC Series Projector Mounts.

HOW TO ORDER

1. Determine if you need a ceiling mount or table stand for your application.
2. Verify the dimensions of the projector will fit in the stacker.
3. Determine if you need the standard model or further customization with additional accessories.
4. Order one RPA or UPC Ceiling Mount for each projector. Determine which projector mount to use by looking in the cross-reference chart.
5. Fax or e-mail your order to Customer Service at 877.894.6918 (domestic) or 952.894.6918 (international), or orders@chiefmfg.com.

SPECIFICATIONS

Model	Roll/Pitch/Yaw	Overall Dimensions W x H x D	Color	Weight Capacity
LCD-2C	+/- 4°/25°/12°	13-3/4" x 24" x 7-3/16" (349 x 610 x 183 mm)	Black	100 lbs (45.5 kg)
LCD-2TS	+/- 4°/25°/12°	20" x 24" x 16" (508 x 610 x 406 mm)	Black	100 lbs (45.5 kg)

ACCESSORIES

Fixed Extension Columns

- CMA-024 2' (0.6 m)
- CMA-036 3' (0.9 m)
- CMA-048 4' (1.2 m)
- CMA-060 5' (1.5 m)
- CMA-072 6' (1.8 m)

Lateral Shift

- LSB-100 Lateral Shift Bracket

For more information on Stacker accessories, see pages 22-27.



PROJECTOR STACKERS

CUSTOM SOLUTION

FAQ

1. **What is the difference between the models ending in U and E?**

A The Ektagraphic III projector is specified with U, Ektapro is specified with E.

2. **Are the slide stackers ceiling mountable?**

A Only the MSU-1000C/MSE-1000C.

3. **How do I change over from one slide projector to another?**

A A hold-down kit can be purchased for the new projector.

4. **Can I add more shelves onto any Micro-Set stand?**

A Yes, order an MSU or MSE-1000 add-on unit. You can also add shelves onto the Adjusta-Set products by ordering an MSU or MSE-1000 add-on unit. Note: The add-on shelves are not vertically adjustable.

HOW TO ORDER

1. Determine how many tiers or levels you need. Specify suffix based on total tier level: 2000 for two tiers, etc.

2. Determine which projector model is being used. Specify prefix: MSU or ASU for Ektagraphic III; and MSE or ASE for Ektapro.

3. Decide if you need vertical height adjustment between projector cradles for variable lens center spacing and specify AS prefix. If it is not needed, specify MS prefix.

4. Choose any appropriate accessories needed for your application.

5. Fax or e-mail your order to Customer Service at 877.894.6918 (domestic) or 952.894.6918 (international), or orders@chiefmfg.com.

MICRO-SET™ & ADJUSTA-SET™ SLIDE STACKERS

Aligns multiple projectors and slide projectors for reliable presentations.

■ Available in one-, two- and three-tier models

With the option of additional add-on shelves to fit all of your installation needs.

■ Includes Patented Gimbal Action™

Enabling smooth rotation of the projector in any direction by pivoting near the projector's center of gravity.

■ Accommodates Kodak® Ektagraphic III (MSU and ASU models) or Ektapro® (MSE & ASE models)

■ Independent Roll, Pitch & Yaw

Easy micrometer adjustments for precise image registration.

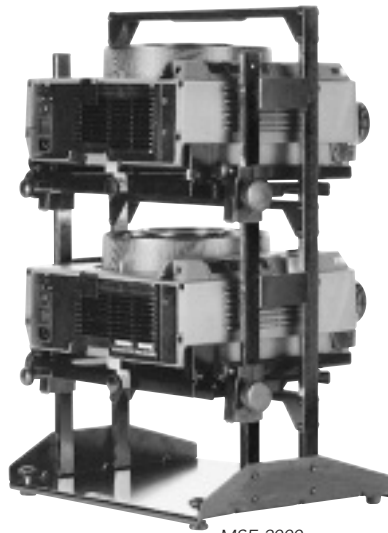

MSE-2000

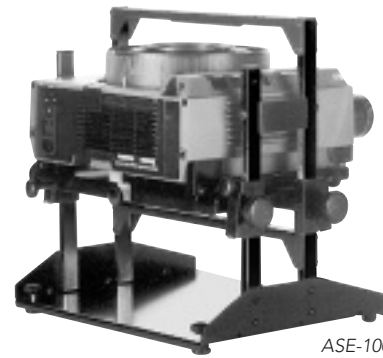

ASE-1000B

■ Solid Construction

– Ensures a stable image during projection
– Sturdy bottom shelf provides a convenient location for most dissolvers

■ Flexibility

Adjustable vertical projector spacing (for Adjusta-Set products only).

■ Positive Projector Hold Down

Rigidly secures projector to stacker tray.

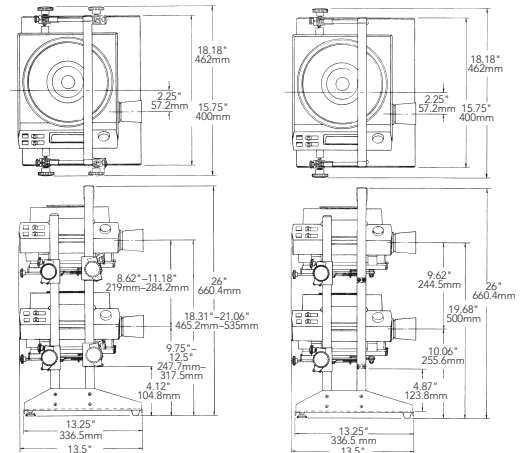

Adjusta-Set™

Micro-Set™

ACCESSORIES

MICRO-SET, AJUSTA-SET

- GW-200
- HD-120
- HD-150
- LS-135

For more information on Micro-Set and Adjusta-Set accessories, see page 24.

SPECIFICATIONS

Model	Roll/Pitch/Yaw	Overall Dimensions W x H x D	Projector Space W x H x D	Dissolver Space W x H x D	Color
Micro-Set	+/- 7°/20°/7°	18-3/16" x 26" x 13-1/4" (478 x 660 x 337 mm)	14-1/2" x 8" x 10" (368 x 203 x 254 mm)	4-7/8" x 14-1/2" x 13-1/2" (124 x 368 x 343 mm)	Black
Adjusta-Set	+/- 7°/20°/7°	18-3/16" x 26" x 13-1/4" (478 x 660 x 337 mm)	14-1/2" x 8" x 10" (368 x 203 x 254 mm)	4-1/8" x 14-1/2" x 13-1/2" (105 x 368 x 343 mm)	Black

NOTES:



PROJECTOR SECURITY

FAQ

1. Why are there three unique key options for the PL-1 series?

A The three key option provides greater flexibility for multiple installations within one site.

2. Is the PL-1 Series compatible with the RPA-U Universal Projector Mount?

A Yes. All RPA Series projector mounts are compatible.

3. How do I install the PL-1 Series when it does not sit flush on the SLB top?

A Spacers are included in the PL-1 Series kit that can be installed on the SLB threaded studs to provide additional clearance.

4. How do I flush mount a projector with the PL-1 Series?

A The PL-1 Series is only compatible with 1-1/2" NPT extension column installations.

HOW TO ORDER

1. Verify that you have a new or pre-existing RPA Series projector ceiling mount installation.

2. Order one of the three PL-1 Series Projector Lock options (PL-1A, PL-1B, PL-1C). The only difference in the kit options is the key set used to open the PL-1 series.

NEW PL-1™ PROJECTOR LOCK

Provides keyed locking to RPA Series projector mounts. Ideal for schools and gymnasiums, where security may be an issue.

Flexible Installation

Can be built used with new and existing installations.

Universal Solution

For all RPA Series projector mounts.

Slotted Design

Provides projector ventilation.

Integrated Cable Management

Allows standard routing of cables through 1-1/2" NPT Column (column not included).

Keyed Lock

For an added level of security.

Solid Steel Construction

Designed with heavy-gauge steel for ultimate strength.

3 Unique Locks Available

For multiple installations within one site (Indicate PL-1A, PL-1B, PL-1C).



PL-1 shown in open position.

Easy to Maintain

Sliding doors maintain easy lamp and filter access.

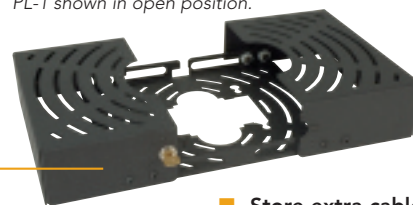

Store extra cables inside box for a clean look.

SPECIFICATIONS

Dimensions	13-1/4" x 3-1/3" x 11-7/16"
WxDxH	(337 x 85 x 291 mm)
Color	Black
Use	RPA, RPA-U Projectors

SECURITY ACCESSORIES

SECURITY ACCESSORIES	PAGE
PG-1A, PG-2A Projector Guards	21
HC-1 Heavy-Duty Cable System	27
PL-4 Projector Lock	27
LC-1 Cable Lock	27
SA-1 Security Anchor	27
SSC Security Screw Cover Kits	27

PG-1A™ & PG-2A™ PROJECTOR GUARDS

Top security, full enclosure solutions. Ideal for schools and gymnasiums, where theft or recreational damage is possible.

Prevents Damage

Fully encloses projectors in a locked steel cage to protect from theft or recreational damage.

Slotted Design

Provides proper projector ventilation.

Integrated Cable Management

Allows standard routing of cables through 1-1/2" NPT Extension Column.

Maximum Security

- Locks with security screws
- Padlocks can be added for additional security

Hinged Doors

Allows easy access for projector maintenance.

Adjustable Front Opening

Accommodates different lens positions.

Solid Steel Construction

Designed with heavy-gauge steel for ultimate strength.

Maintain Projector Settings

Mount with pre-existing installations without disturbing projector settings.

PG-2A Projector Guard

For use with smaller projector models.

NEW

PG-1A

1. Can I install the PG Series on a pre-existing installation?
 - A Yes. As long as the installation uses a 1 1/2" NPT extension column.
2. Do I have to use the RPA Series Mount to use the PG Series?
 - A No. The Guard can be installed using any 1 1/2" NPT extension column. It can also be installed directly to the top of the RPA.
3. Does the PG Series allow easy access to the projector for maintenance?
 - A Yes. You can easily unlock and remove the PG Series from the projector without detaching the projector or losing projector registration.
4. Does the PG Series accommodate the roll, pitch and yaw adjustments of the RPA?
 - A Yes. The PG Series accommodates all features of the RPA Series.

HOW TO ORDER

1. Verify your projector and all components (including projector mount, bracket and cables) will fit into the overall dimensions.
2. Verify that your installation includes a 1-1/2" NPT extension column

SECURITY ACCESSORIES

PAGE

HC-1 Heavy-Duty Cable System	27
LC-1 Cable Lock	27
PL-1 Projector Lock	20
PL-4 Projector Lock	27
SA-1 Security Anchor	27
SSC Security Screw Cover Kits	27

SPECIFICATIONS

PG-1A	
Dimensions WxDxH	20-1/2" x 20-3/8" x 10-3/16" (52.1 x 51.8 x 25.9 cm)
PG-2A	
Dimensions: WxD xH	16-1/2" x 16-3/8" x 10-3/16" (41.9 x 41.6 x 25.9 x cm)
Color	Black
Use	Most projectors



PROJECTOR ACCESSORIES

*To order select accessories in white or silver, simply add a "W" for white or an "S" for silver to the end of the part number.

CEILING PLATES

POPULAR PRODUCT

CMA™-100 8" (203 mm) CEILING PLATE WITH ATTACHED ADJUSTABLE 1-1/2" NPT COLUMN

- Universal solution for most structural ceiling installations
 - Easily achieve the desired drop distance, 24-1/4"– 46" (61.6 -116.8 cm)
 - Adjustable in 3/4" (19 mm) increments
 - CMA-260 available for attaching to 2" NPT
 - Provides unmatched rigidity
 - Weight Capacity: 500 lbs (227 kg)
- NEW** ■ Now available in black, white or silver*



POPULAR PRODUCT

CMA™-101 5" (127 mm) DESIGNER CEILING PLATE WITH 1-1/2" NPT OPENING

- Cost effective, attractive solution for simple installs
- Can hold equipment using all four holes or two opposing holes
- 4" x 4" (102 x 102 mm) mounting pattern is designed to allow use of 3/8" (10 mm) mounting bolts
- Includes set screw to secure a 1-1/2" NPT to the ceiling plate
- Includes All-Points Security
- Weight Capacity: 500 lbs (227 kg)



CMA™-105 4" (102 mm) CEILING PLATE WITH 1-1/2" NPT OPENING

- Combines with fixed or adjustable CMA extension columns to customize your installation
- Great for installations where a short extension column is used, or when there isn't space for a larger plate
- Includes set screw
- Weight Capacity: 500 lbs (227 kg)



POPULAR PRODUCT

CMA™-110 8" (203 mm) CEILING PLATE WITH 1-1/2" NPT OPENING

- Combines with fixed or adjustable CMA extension columns to customize your installation
- CMA-210 available for attaching to 2" NPT
- Includes set screw
- Weight Capacity: 500 lbs (227 kg)

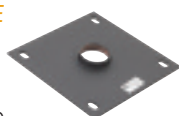

CMA™-115 6" (152 mm) CEILING PLATE WITH 1-1/2" NPT OPENING

- Combines with fixed or adjustable CMA extension columns to customize your installation
- Includes set screw
- Weight Capacity: 500 lbs (227 kg)

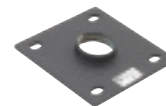

NEW

CMA™-330 OFFSET CEILING PLATE

- Routes projector cables through the extension column and out the top of the ceiling plate for better cable management
- Includes an 8" (203 mm) square ceiling plate with a 1-3/4" (45 mm) high offset
- Overall Height: 4-1/2" (114 mm)
- Attaches to a 1-1/2" NPT threaded extension column; can also attach to 2" NPT column with the CMA-332
- Weight Capacity: 500 lbs (227 kg)



CMA™-345 STRUCTURAL CEILING PLATE

- Flexible neoprene rubber joint to minimize shock and vibration – great for earthquake-prone areas!
- Overall Height: 4-1/2" (114 mm)
- Attaches to a 1-1/2" NPT threaded extension column
- Weight Capacity: 500 lbs (227 kg)



POPULAR PRODUCT

CMA™-395 100° ANGLED CEILING PLATE WITH THREADED COUPLER

- Adjusts from -5° to +95° to level an angled ceiling
- Attaches to a 1-1/2" NPT threaded extension column
- Two slotted mounting holes
- Includes set screw
- Weight Capacity: 500 lbs (227 kg)



CMA™-700 EASY INSTALLATION KIT

- Provides all the accessories you need for a complete structural ceiling installation
 - Easy to install
 - Includes a 6" x 6" (152 x 152 mm) ceiling plate and adjustable extension column that extends 12"–18" (305 – 457 mm)
 - Weight Capacity: 500 lbs (227 kg)
- NEW** ■ Now available in black, white or silver*



CEILING KITS

CMA™-165 INTERNAL JOIST CEILING KIT

- Suspends projector between ceiling joists
- Similar to a ceiling fan installation
- Installs with just a 4" (102 mm) hole in the ceiling
- Cable management system for a clean installation
- Attaches to 1-1/2" NPT extension column
- Weight Capacity: 50 lbs (22.7 kg)



POPULAR PRODUCT

CMA™-440 LIGHTWEIGHT SUSPENDED CEILING KIT



- Easy to install
- Easy clamping to ceiling tracks with minimal assembly
- Secured with four tie wires and a safety cable
- Infinite adjustment allows positioning of a 1-1/2" NPT opening at any location within a 2' x 2' (0.6 x 0.6 m) or 2' x 4' (0.6 x 1.2 m) ceiling tile
- Includes 10' (3 m) safety cable, 20' (6.1 m) strand wire, two outlet knockouts, four turnbuckles, wood eye bolts, concrete anchors and a chrome ring
- Weight Capacity: 50 lbs (22.7 kg)



Common Installation

- A flexible solution for mounting projectors from a suspended ceiling
- Mount above an existing ceiling tile (ceiling tile not shown)
- Safety cable and hardware included

CMA™-450 SUSPENDED CEILING KIT



- Easy to install and clamp to ceiling track
- 2' x 2' (0.6 x 0.6 m) plate sits unseen above a suspended ceiling
- Secured with four tie wires and a safety cable
- Nine possible mounting hole positions with threaded end for 1-1/2" NPT extension column
- Includes 10' (3 m) safety cable, 20' (6.1 m) strand wire, two outlet knockouts, four turnbuckles, wood eye bolts, concrete anchors and a chrome finishing ring
- Weight Capacity: 250 lbs (113.6 kg) center hole, 125 lbs (56.8 kg) side and corner holes



CMA™-455 SUSPENDED CEILING REPLACEMENT KIT



- Quick installation without cutting any ceiling tiles
- Designed to replace a 2' x 2' (0.6 x 0.6 m) ceiling tile or sit above the suspended ceiling
- Secured with four tie wires and a safety cable
- Threaded hole attaches to a 1-1/2" NPT extension column
- Includes 10' (3 m) safety cable, 20' (6.1 m) strand wire, two outlet knockouts, four turnbuckles, wood eye bolts and concrete anchors
- Weight Capacity: 250 lbs (113.6 kg)





PROJECTOR ACCESSORIES

LATERAL SHIFT

LSB™-100 LATERAL SHIFT FOR LCD/DLP PROJECTOR MOUNTS

- Allows 3" (76 mm) of right/left lateral adjustment to center the lens
- Maintains quick disconnect feature of the RPA for easy projector reconnection
- Includes All-Points™ Security System hardware
- Additional 2-1/4" (57 mm) right/left lateral adjustment is possible for projectors under 15 lbs (6.8 kg)
- Weight Capacity: 50 lbs (22.7 kg)



CABLE COVER

CMA™-274/275 QUICK-SNAP CABLE COVERS

- Cable management cover saves installation time!
- Quickly adapts to 1-1/2" and 2" NPT
- Hides cables and creates an aesthetic look
- Unique cover design snaps on easily
- Great alternative to routing cables through the extension column
- CMA-274 includes one 4' (1.2 m) section, CMA-275 includes three 4' (1.2 m) sections that can easily be cut to size



EXTENSION COLUMNS

CMA™ FIXED EXTENSION COLUMNS

- Use with any 1-1/2" NPT accessory to lower the projector to desired height
- Includes 1-1/2" NPT column threaded on both ends, 3'-6' (0.9-1.8 m) lengths
- Weight Capacity: 500 lbs (227 kg)



Model	Length	Model	Length
CMA-003	3" (76 mm)	CMA-024	2' (0.6 m)
CMA-006*	6" (152 mm)	CMA-036	3' (0.9 m)
CMA-008	8" (203 mm)	CMA-048	4' (1.2 m)
CMA-012	12" (305 mm)	CMA-060	5' (1.5 m)
CMA-018	18" (457 mm)	CMA-072	6' (1.8 m)

* Now available in black, white or silver. To order this accessory in white or silver, simply add a "W" for white or an "S" for silver to the end of the part number.

CMA™ ADJUSTABLE EXTENSION COLUMNS

- Use with any 1-1/2" NPT accessory to lower the projector to desired height
- Provides range of height adjustment in 1" (25 mm) increments, depending on the model
- Includes 1-1/2" NPT Column threaded on both ends
- Includes set screws for added rigidity
- Weight Capacity: 500 lbs (227 kg)



Model	Length	Model	Length
CMA-006009	6"-9" (152-229 mm)	CMA-0507	5'-7' (1.5-2.1 m)
CMA-009012	9"-12" (229-305 mm)	CMA-0608	6'-8' (1.8-2.4 m)
CMA-012018*	12"-18" (305-457 mm)	CMA-0709	7'-9' (2.1-2.7 m)
CMA-018024	18"-24" (45.7-61 cm)	CMA-0810	8'-10' (2.4-3.1 m)
CMA-0203	2'-3' (0.6-0.9 m)	CMA-0911	9'-11' (2.7-3.4 m)
CMA-0305	3'-5' (0.9-1.5 m)	CMA-1012**	10'-12' (3.1-3.7 m)
CMA-0406	4'-6' (1.2-1.8 m)		

* Now available in black, white or silver. To order this accessory in white or silver, simply add a "W" for white or an "S" for silver to the end of the part number.

**CMA-1012 Adjustable Extension Column cannot ship by UPS due to length.

For information on the following accessories, visit www.chiefmfg.com.

CMA™-250

- Flush Mount Adapter for LCDA Series mounts

LPK™-1

- Low-Profile Mounting Kit for VCM Series mounts

PROJECTOR STACKER ACCESSORIES

(for MS & AS Series)

- HD™-120 EK-III Hold Down Kit
- HD™-150 Ektapro Hold Down Kit
- GW™-200 Lens Accessory
- LS™-135 Lens Support Bracket

STRUCTURAL ADAPTERS

CMA™-300 PIPE CLAMP

- Clamps onto a 1-9/10"–3-1/2" (48–89 mm) OD horizontal pipe
- Allows cable access
- Attaches to 1-1/2" NPT threaded extension column
- Weight Capacity: 300 lbs (136.4 kg)



CMA™-360 I-BEAM CLAMP

- Attaches a 1-1/2" NPT column to I-beam truss from 2-5/16"–12" (59–305 mm) wide
- Weight Capacity: 250 lbs (113.6 kg)



CMA™-362 C-CLAMP

- Great for mounting equipment in exhibit booths
- Clamps to any structure up to 2-3/4" (70 mm) OD, including 2" x 4" structures
- Attaches to 1-1/2" NPT threaded extension columns
- Quick, versatile installation of presentation equipment
- Allows cable access through column
- Weight Capacity: 250 lbs (113.6 kg)



CMA™-365 TRUSS CEILING ADAPTER

- Attaches a 1-1/2" threaded extension column to square, round, rectangular or I-beam truss up to 3" (76 mm) in OD with a 3/4" (19 mm) minimum OD
- Weight Capacity: 250 lbs (113.6 kg)



CMA™-366 ARCHITECTURAL SPANNING ADAPTER

- Spans truss systems 5"–18" (127–457 mm) for easy overhead installation of equipment in buildings and exhibit booths
- Accommodates truss using up to 2" (51 mm) OD round or 1-7/8" (48 mm) square pipe
- Attaches to 1-1/2" NPT threaded extension column
- Cable management through column
- Attach center plate at several different spots on adapter
- Weight Capacity: 250 lbs (113.6 kg)



CMA™-372 OFFSET UNISTRUT® ADAPTER

- Quickly installs to all styles of 1-5/8" (41.3 mm) Unistrut®/U-Channel
- Cable management through pole and directly out of Unistrut adapter
- Attaches to 1-1/2" NPT threaded extension column
- Ships with spring nuts and bolts for attaching to Unistrut®/U-Channel
- Weight Capacity: 500 lbs (227 kg)



CMA™-380 CONCRETE FASTENER KIT

- Includes four concrete fasteners for concrete or brick installations



CMA™-385 INTERNAL JOIST MOUNT

- Expands to bridge ceiling joists on 10"–23" (254–584 mm) centers
- Adjustable clamping bracket with threaded fitting for 1-1/2" NPT threaded extension columns
- Cable management through column
- Weight Capacity: 300 lbs (136 kg)



CMA™-390 16" (406 mm) / CMA-391 24" (61 cm) ON-CENTER CEILING PLATES

- Attach to finished ceilings using the included lag bolts:
 - 16" (406 mm) on-center joists use the CMA-390
 - 24" (61 cm) on-center joists use the CMA-391
- Can be used on structural ceilings using concrete anchors (CMA-380)
- Attaches to 1-1/2" NPT threaded extension columns
- Cable management through column
- Includes set screw
- Weight Capacity: 300 lbs (136 kg)



WMA™-300 WALL MOUNT ARM

- Use to wall mount the RPA, UPC or LCD A projector mounts
- Includes 3" (76 mm) extension column
- Extends 18-1/4" (464 mm) from wall
- Weight Capacity: 150 lbs (68 kg) concrete installation, 125 lbs (56.8 kg) wood stud installation





PROJECTOR ACCESSORIES

*To order select accessories in white or silver, simply add a "W" for white or an "S" for silver to the end of the part number.

OTHER INSTALLATION ADAPTERS

CMA™-151 1-1/2" TO 1" ADAPTER/REDUCER



- Adapts RPA Mount or other 1-1/2" NPT accessory for use on a 1" NPT column

CMA™-152 1-1/2" TO 1-1/2" NPT COUPLER



- Manages messy cables
- Combines two 1-1/2" NPT columns for added length
- Slot allows easy cable access
- Includes two set screws for stability and security
- Weight Capacity: 500 lbs (227 kg)

CMA™-160 INSTALLATION JOB BOX



- Provides one central location for electrical hook-ups, cables and equipment
- Attaches inline to two 1-1/2" NPT columns
- Includes outlet knockouts and space to hold wiring and electrical equipment
- Remains hidden above the ceiling
- Plenum rated
- Weight Capacity: 250 lbs (113.6 kg)



CMA™-270 THREADED PIPE COUPLER



- Attaches two 1-1/2" NPT columns together for added length
- Adds 2-1/16" (52.4 mm) height to installation
- Includes two set screws for security, stability and safety
- Weight Capacity: 500 lbs (227 kg)
- Now available in black, white or silver*



CMA™-340 SUPPORT BRACKET AND CABLE ASSEMBLY

- Used with long extension installations
- Increases rigidity of installation and reduces sway
- Attaches to a 1-1/2" or 2" NPT extension column
- Includes a bracket, four cables and four turnbuckles
- Weight Capacity: 500 lbs (227 kg)



CMA™-351 HEAVY-DUTY SWIVEL ADAPTER WITH STOPS



- Allows smooth axis rotation or the ability to set swivel 0°–330°
- Quick rotation solution for projecting on more than one wall
- Attaches to a 1-1/2" NPT threaded extension column
- Weight Capacity: 500 lbs (227 kg)

CMA™-640/641/642 FINISHING RINGS



- Covers hole where extension column passes through the ceiling tile for an aesthetic appeal
- Ring is hinged to open
- CMA-640 – 1/2" (13 mm), CMA-641 – 3/4" (19 mm), CMA-642 – 1" (25 mm)

QD-1™ QUICK DISCONNECT



- Quick release by loosening flange nuts and removing the safety pin
- Helpful with mounting heavy equipment like the VCM
- Attaches to 1-1/2" NPT threaded extension column
- Weight Capacity: 500 lbs (227 kg)

XY-1™ HEAVY-DUTY LATERAL SHIFT BRACKET



- Allows 4" (102 mm) adjustment in any direction
- Position on a 1-1/2" NPT extension column for right/left or fore/aft adjustment
- Alleviates obstacles in the pathway of column drop

CMA™-347 VIBRATION ISOLATOR



- Reduces image movement due to building vibration
- Three moment arms distribute weight to stabilize projector and reduce vibration
- Springs, dampeners and moment arms help isolate vibration
- Weight Capacity: 0-15 lbs (0-6.8 kg) or 15-35 lbs (6.8-15.9 kg)

NOT PICTURED

CMA™-273 END CAP

NEW

- Covers the end of a 1-1/2" NPT Column for a finished appearance

NEW

CMA™-251 ADAPTER/REDUCER

- 2" – 1-1/2" NPT

SECURITY ACCESSORIES

HC-1™ HEAVY-DUTY CABLE SYSTEM

- Includes Chief's exclusive security anchor, 1/4" x 5' (6.4 mm - 1.5 m) vinyl-coated cable, 40 mm padlock, two steel security pads with patented rotating cable fasteners and a tube of instant adhesive
- SA-1 Security Anchor included in the system



LC-1™ CABLE LOCK

- Includes a coiled cable that extends 6' (1.8 m), two steel security pads, a 2 g tube of super glue gel and a 30 mm padlock



SA-1™ SECURITY ANCHOR

- Attaches to NPT pipe, truss work and other components
- Security shroud is held in position by a security cable or padlock (not included) blocking access to the hardware



PL-G™ 1A/2A PROJECTOR GUARDS – (PG 21)

- Fully encloses projectors in a locked steel cage to protect from theft or recreational damage
- Mount to pre-existing or new installations
- Adjustable front opening accommodates different lens positions
- Hinged doors allow easy access for projector maintenance
- Solid steel construction
- Accommodates projectors up to (WxHxD) 20-3/8" x 7-1/2" x 20" (51.8 x 19 x 50.8 cm)



PG-1A



PG-2A – Accommodates smaller projector models

NEW

PL-1™ PROJECTOR LOCK – (PG 20)

- Provides keyed locking to projector installations
- 13-1/4" x 3-1/3" x 11-7/16" (337 x 95 x 291 mm)
- Made from heavy-gauge steel
- 3 unique locks available (PL-1A, PL-1B, PL-1C)



PL-4™ PROJECTOR LOCK

- Lock body is 1" diameter x 1-1/4" (25 x 31.8 mm)
- Made from aircraft aluminum
- Seamless housing with a seven-pin tumbler locking mechanism (two keys provided)
- 3M™ adhesive secures lock to projector



SSC™ SECURITY SCREW COVER KITS

- Provides added protection against equipment theft
- Prohibits access to screws by covering hardware and locking with padlocks or cable
- Four kits available:
 - SSC-1 includes 3 covers for screws up to #10 (M5)
 - SSC-2 includes 3 covers for screws up to 1/4" (M6)
 - SSC-3 includes 3 covers for screws up to 5/16" (M8)
 - SSC-4 for the RPA
- Padlocks and cable not included





SECTION 2 LARGE FLAT PANEL SOLUTIONS

large
40-65" Screens



At Chief, we know that wall mounts for today's large flat panel TVs and monitors are critical components. That's why we designed a complete selection of flat panel mounts that are precision-engineered for stability, security, functionality and real-world reliability. Whether the application is a home theater, boardroom, conference center or classroom, Chief has the right large flat panel mounting solution.

HOW TO CHOOSE A LARGE FLAT PANEL MOUNT

Choosing the right large flat panel mount ensures the best performance. All Chief Large Flat Panel Mounts offer industry-leading features:

- Quality, Innovative Designs – Low-profile designs are paramount for professional applications
- Interchangeable Interface Brackets – Flexibility to move a display from a wall to a table stand to a mobile cart all with the same brackets
- Advanced Security – Chief offers an exclusive Q-Latch™ Mounting System
- Service Excellence for all your installation needs
- Quick Shipping – Most Chief mounts ship within 24 hours

Q-LATCH™ MOUNTING SYSTEM

Chief's Q-Latch Mounting System safely secures screens to the mount in three easy steps and is included with the large flat panel mounts. Mounting buttons on the interface bracket easily drop into the Q-slots on the mount with minimum overhead clearance needed. The 14" square Q-Latch System allows flat panel displays to be installed in portrait or landscape positions. Now available with integrated security with the addition of a padlock.



NEW Integrated Security

LARGE FLAT PANEL



CHIEF ADDS VALUE TO EVERY MOUNT WE MAKE.

End-User Focused

■ Customer-Friendly Designs

- Ultra low-profile designs keep mounts hidden behind the screen
- Fingertip tilt adjustments for custom screen angles
- Lateral shift allows for ideal viewing positions

■ Complete Solution

Compatible with multiple accessories to customize any installation.

■ Ultra Low-Profile Designs

Ensures the mount stays hidden behind the screen.

Proven Quality

■ Industry Leader

27 years of engineering excellence.

■ Solid Steel Construction

Designed with heavy-gauge steel.

■ Rigorous Testing

Every mount undergoes a series of tests to ensure safe and secure installations.

■ Custom and Universal Solutions

Choose from an expansive standard product offering, or utilize Chief's design expertise for a custom fit.

Faster Installation

■ Rapid Level™ System

Provides hands-free leveling of mount on the wall.

■ Q-Latch™ Mounting System

Safely and easily secures the mount and locks it into place.

■ Integrated Lateral Shift

Provides ultimate installation flexibility.

Superior Service

■ Expert and Accessible Customer Service

- Knowledgeable support from experienced industry professionals
- Order tracking to technical issues in one phone call

■ On-Time Delivery

Most products ship within 24 hours after receipt of purchase order.



The addition of Chief's new PSB-U Universal Interface allows most large flat panel mounts to be ordered in a universal configuration.



Paul Smith, Design Engineer, works on the next new product solution.



Chief's patented Q-Latch Mounting System allows installation in 3 easy steps.



Emma Halls, Chief Customer Service, makes sure your order ships within 24 hours.

LARGE FLAT PANEL PRODUCT OVERVIEW

UNIVERSAL – (Add Suffix -U)
Fits over 90% of screen models.

CUSTOM – (Add Suffix -XXXX)
See www.chiefmfg.com/custom
for custom four digit reference
numbers.

large
40 – 65" TVs

FIXED WALL MOUNTS

PSM™ PG 32
Fixed Wall Mount – Custom,
one-piece design (not available in
universal design)



MAX WEIGHT: 175 lbs B

PST™ **FUSION**
FIXED AND TILT WALL MOUNTS
Fixed Wall Mount – Custom or
Universal, two-piece design



MAX WEIGHT: 200 lbs B NEW

PG 33

TILT WALL MOUNTS

PRO™ PG 34
Lockable Tilt Wall Mount



MAX WEIGHT: 200 lbs B NEW

PLP™
Patented Pull-N-Tilt™ Wall
Mount with fingertip adjustment



MAX WEIGHT: 200 lbs B NEW

PG 35

REACTION SWING ARM MOUNTS

PWR™ PG 36
Single Swing Arm Wall Mount



MAX WEIGHT: 125 lbs 25" EXTENSION
NEW S B

TRUSS & POLE MOUNTS

TPS™ PG 42
Fixed Truss Mount



MAX WEIGHT: 175 lbs B

TPM™/TPP™ PG 43
Fingertip Tilt Pole/Truss Mount



MAX WEIGHT: 200 lbs B

PSS™/PTS™ PG 44
Table Stands



MAX WEIGHT: 150 lbs S B

To specify color options, add S (Silver) or B (Black) to the model number.
FOR A COMPLETE LIST OF FLAT PANEL ACCESSORIES, VISIT WWW.CHIEFMFG.COM

LARGE FLAT PANEL PRODUCT OVERVIEW

SWING ARM MOUNTS

REACTION
SWING ARM MOUNTS

PNR™

PG 37

Dual Swing Arm Wall Mount



NEW

S B

MAX WEIGHT: 200 lbs 25" EXTENSION

REACTION
SWING ARM MOUNTS

PDR™

PG 38

Dual Swing Arm Wall Mount



NEW

S B

MAX WEIGHT: 200 lbs 37" EXTENSION

CEILING MOUNTS

PCM™

PG 40

Single Ceiling Mount

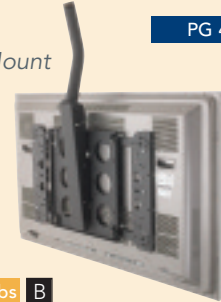

MAX WEIGHT: 175 lbs B

PDC™

PG 40

Dual Ceiling Mount



MAX WEIGHT: 350 lbs B

STAND & CART MOUNTS

PFS™

PG 45

Floor Stand



MAX WEIGHT: 100 lbs B

PFB™

PG 46

Dual Pole Floor Stand



MAX WEIGHT: 300 lbs B

PTC™

PG 47

Mobile Cart



MAX WEIGHT: 150 lbs B

PPC™/PPD™

PG 48

Presenter's Cart



MAX WEIGHT: 200 lbs B

LARGE FLAT PANEL WALL MOUNTS – FIXED

CUSTOM SOLUTION

FAQ

1. Do I need to order a separate interface bracket?

A No, each mount is designed to fit directly to your screen. Determine which part number will accommodate your display by looking up the manufacturer and model number in the cross-reference chart.

2. Can I view the screen in portrait mode?

A No, the PSM maintains a highly economical price and low-profile depth through a one-piece design.

3. Can I lock my display to the mount?

A Yes, Chief's exclusive Q-Latch Mounting System engages the latch around the Q-button for a positive connection, preventing the display from dislodging. Additional security accessories are available to padlock the display to the mount.

HOW TO ORDER

1. Determine which style mount will best suit your needs.

Note: flat panel displays smaller than 26" generally require a mount from our Small or Medium Flat Panel Display line. Check the cross-reference chart to verify.

2. For the correct model number, look up your display in the cross-reference chart or on the website.

3. Fax or e-mail your order to Customer Service at 877.894.6918 (Domestic) or 952.894.6918 (International), or orders@chiefmfg.com.

PSM™ FIXED WALL MOUNT

Quick, cost-effective installation for all basic, large flat panel display applications.



■ Custom One-Piece Solution!

- One-piece mount, custom-configured for each display to reduce installation time and shipping costs
- Ultra low profile, 1" (25 mm) standard mount depth
- Landscape view only

■ Built-in Cable Management

For a clean, uncluttered installation.

■ Integrated Lateral Shift

For ultimate flexibility.

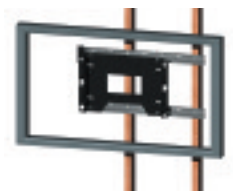
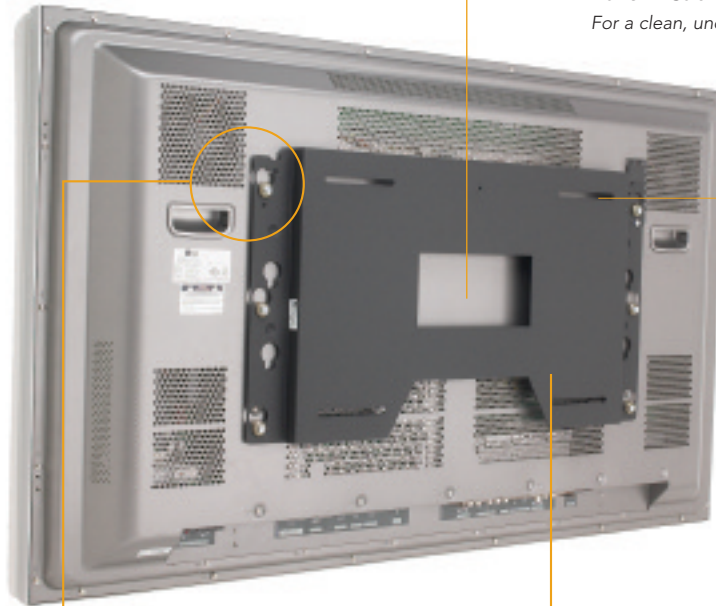

PAC-125, shown with the PSM, provides increased lateral shift and allows the screen to move off the center of the mounting studs. (PAC-125 sold separately)

■ Exclusive Q-Latch™ Mounting System

- Offers quick connect/disconnect
- Secures display with a latching flag



■ Heavy-Duty Steel Construction

Wall mount uses more surface area for balance and stability.

ALSO AVAILABLE: PSMH™ (NOT SHOWN)

- For displays over 175 lbs (79.5 kg)

SPECIFICATIONS

Depth from Wall	approximately 1" (25 mm)
Dimensions WxHxD	Varies depending on display manufacturer
Mounts on Studs	16" (406 mm) on-center
Color	Black
Weight Capacity	175 lbs (79.5 kg)

RECOMMENDED ACCESSORIES

	PAGE
ENS Lateral Shift Extrusions	53
PAC-115 Steel Stud/Drywall Anchor Kit	52
PAC-125 Lateral Shift Accessory	53
PAC-126 Lateral Shift Accessory	53
PAC-130* Q-Latch™ Lockable latch	52
PAC-135* Q-Latch™ Lockable latch with padlock	52

*Not compatible with Chief models 2095, 2096, 2097, 2391.

LARGE FLAT PANEL WALL MOUNTS – FIXED

CUSTOM OR UNIVERSAL

NEW

FUSION
FIXED AND TILT WALL MOUNTS

PST™ FIXED WALL MOUNT

Installer-friendly features and ultra low-profile design is ideal for digital display or retail. Sets the industry standard for low-profile mounts!



Q-Latch™ Mounting System

- Offers quick connect/disconnect
- Secures display with a latching flag
- Includes integrated security with the addition of a padlock



Cable Management

Expanded wall plate opening provides cable access and reduces risk of outlet interference.

Rapid Level™ System

Provides hands-free leveling of mount on wall.

Ultra Low-Profile Design

Ensures the mount stays hidden behind the screen.

Portrait Installation

PST-16 –16" (40 cm) stud only option allows for portrait installation.



PAC-400, shown with the PST, allows quick and easy movement from portrait to landscape positions without removing the screen. (PAC-400 sold separately)

Integrated Lateral Shift

- Provides up to 4" of shift left or right of 16" centers
- Allows for 16", 20" and 24" center stud system mounting

Solid Steel Construction

Designed with heavy-gauge steel, press-in studs and lock nuts for ultimate strength.

Multiple Ordering Options

- Custom interface for fast install
- Universal for stocking
- Wall mount without interface for pre-installation

Universal Option

Order PST-U and get PSB-U™ Universal Interface Bracket included.



Optional Accessories

For a complete solution, FUSION Series mounts are compatible with multiple accessories to customize any installation.

ALSO AVAILABLE: PSH™ HEAVY DUTY WALL MOUNT (NOT SHOWN)

- Ideal for Akira® and Orion® 84" and other large flat panel displays

FAQ

1. Why choose the PST Mount?

A Choose the PST Mount for a great universal or custom fixed wall mount solution that allows displays to be installed in either portrait or landscape position. The multiple accessories and low-profile design allow the PST to easily accommodate most applications.

2. Is the PST available as a universal solution?

A Yes. Simply order a PST-U to receive a universal interface bracket. The PST can also be ordered as a custom mount. See ordering steps below.

3. Can I lock my display to the mount?

A Yes, Chief's exclusive Q-Latch Mounting System engages a latch around a Q-button, preventing the display from dislodging. Just add a padlock for security.

HOW TO ORDER

1. For custom model number, look up your display in the cross-reference chart or on the website. Order PST-xxxx, model number includes interface bracket.
2. For universal model number, order PST-U, fits 90% of screen models.
3. Fax or e-mail your order to Customer Service at 877.894.6918 (Domestic) or 952.894.6918 (International), or orders@chiefmfg.com.

RECOMMENDED ACCESSORIES

PAGE

ENS Lateral Shift Extrusions	53
PAC-115 Steel Stud/Drywall Anchor Kit	52
PAC-125 Lateral Shift Accessory	53
PAC-126 Lateral Shift Accessory	53
PAC 251 CPU/DVD/VCR Universal Adapter	50
PAC-300 Side Speaker Adapter	50
PAC-301 Center Channel Speaker Adapter	50
PAC-400 90° Rotation Adapter	50

SPECIFICATIONS

Depth from Wall*	1-5/16" (33 mm)
Dimensions WxHxD	26" x 18-3/8" x 1-5/16" (660 x 467 x 33 mm)
Lateral Shift	4" (102 mm) Left/Right
Mounts on Studs	16", 20", 24" on-center
Color	Black
Weight Capacity	200 lbs (90.7 kg)

* Depth does not include interface bracket.

LARGE FLAT PANEL WALL MOUNTS – TILT

CUSTOM OR UNIVERSAL

NEW

FUSION
FIXED AND TILT WALL MOUNTS

PRO™ LOCKABLE TILT WALL MOUNT

A rock-solid solution for digital displays, retail signage projects and touchscreen applications where a tilt adjustment is needed.



FAQ

1. What is the difference between PRO and PLP tilt wall mounts?

A The PRO provides rock solid lock down tilt adjustment, while the PLP provides fingertip tilt adjustment and expanded cable access.

2. Is the PRO available as a universal solution?

A Yes. Simply order a PRO-U to receive a universal interface bracket with the unit. The PRO can also be ordered as a custom mount. See ordering steps below.

3. Can I lock my display to the mount?

A Yes, Chief's exclusive Q-Latch Mounting System engages a latch around a Q-button, preventing the display from dislodging. Just add a padlock for security.

HOW TO ORDER

1. Determine which style mount will best suit your needs.

Note: flat panel displays smaller than 37" generally require a mount from our Small or Medium Flat Panel Display line. Check the cross-reference chart to verify.

2. For a custom model number, look up your display in the cross-reference chart or on the website. Order PRO-xxxx, model number includes interface bracket.

3. For a universal model number, order PRO-U. Fits 90% of screen models.

4. Fax or e-mail your order to Customer Service at 877.894.6918 (Domestic) or 952.894.6918 (International), or orders@chiefmfg.com.

Q-Latch™ Mounting System

- Offers quick connect/disconnect
- Secures display with a latching flag
- Includes integrated security with the addition of a padlock



Cable Management

Expanded wall plate opening provides cable access and reduces risk of outlet interference.

Ultra Low-Profile Design

Ensures the mount stays hidden behind the screen.

Rapid Level™ System

Provides hands-free leveling of mount on wall.

Integrated Lateral Shift

- Provides up to 4" of shift left or right of 16" centers
- Allows for 16", 20" and 24" center stud system mounting

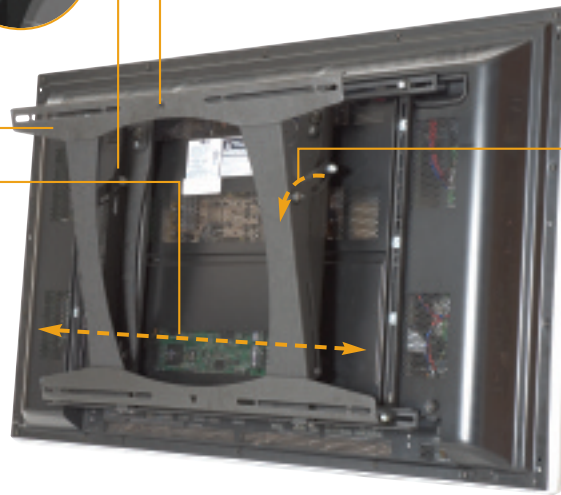

Adjustable Tilt
Wrench-adjustable, 0°–15°.

Solid Steel Construction
Designed with heavy-gauge steel, press-in studs and lock nuts for ultimate strength.

Multiple Ordering Options

- Custom interface for fast install
- Universal for stocking
- Wall mount without interface for pre-installation

Universal Option

Order PRO-U and get a PSB-U™ Universal Interface Bracket included.



Optional Accessories

For a complete solution, FUSION Series mounts are compatible with multiple accessories to customize any installation.

ALSO AVAILABLE: PPH™ HEAVY DUTY TILT WALL MOUNT

- Ideal for Akira® and Orion® 84" and other large flat panel displays

SPECIFICATIONS

Depth From Wall*	1-1/2" (38 mm)
Dimensions WxHxD	26" x 18-3/8" x 1-1/2" (660 x 467 x 38 mm)
Tilt	0°-15°
Lateral Shift	4" (102 mm) Left/Right
Mounts on Studs	16", 20", 24" on-center
Color	Black
Weight Capacity	200 lbs (90.7 kg)

* Depth does not include interface bracket.

RECOMMENDED ACCESSORIES

	PAGE
ENS Lateral Shift Extrusion for Video Walls	53
PAC-115 Steel Stud/Drywall Anchor Kit	52
PAC-125 Lateral Shift Accessory	53
PAC-126 Lateral Shift Accessory	53
PAC-251 CPU/DVD/VCR Universal Adapter	50
PAC-300 Side Speaker Adapter	50
PAC-301 Center Channel Speaker Adapter	50
PAC-400 90° Rotation Adapter	50

LARGE FLAT PANEL WALL MOUNTS – TILT

CUSTOM OR UNIVERSAL

NEW

FUSION
FIXED AND TILT WALL MOUNTS

PLP™ PULL-N-TILT™ WALL MOUNT

Advanced tilt without tools makes this a great solution for home theater and boardroom applications.



Ultra Low-Profile Design

Ensures the mount stays hidden behind the screen.

Q-Latch™ Mounting System

- Offers quick connect/disconnect
- Secures display with a latching flag
- Includes integrated security with the addition of a padlock



PRODUCT FEATURE:

Cable Management

Easy grip handle provides bottom pullout for improved cable access.

Rapid Level™ System

Provides hands-free leveling of mount on wall.

PRODUCT FEATURE:

Pull-N-Tilt™

Patented hand tilt, 0°–15°.

Integrated Lateral Shift

- Provides up to 4" of shift left or right of 16" centers
- Allows for 16", 20" and 24" center stud system mounting

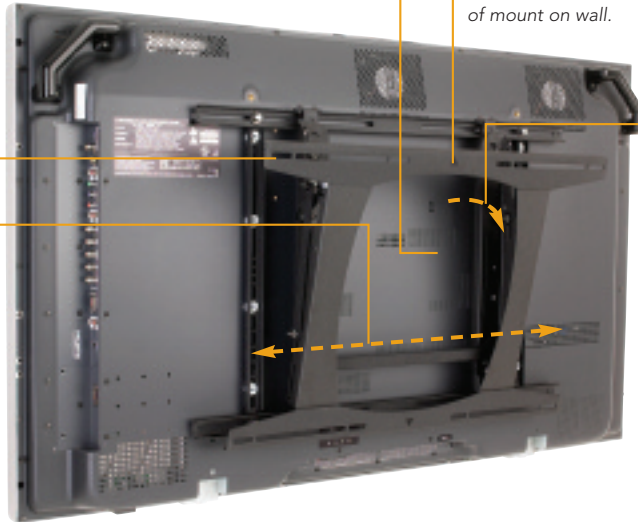

Solid Steel Construction

Designed with heavy-gauge steel, press-in studs and lock nuts for ultimate strength.

Multiple Ordering Options

- Custom interface for fast install
- Universal for stocking
- Wall mount without interface for pre-installation

Optional Accessories

For a complete solution, FUSION Series mounts are compatible with multiple accessories to customize any installation.

Universal Option

Order PLP-U and get a PSB-U™ Universal Interface Bracket included.



FAQ

1. What is the difference between PLP and PRO tilt wall mounts?

A The PLP provides fingertip tilt adjustment and expanded cable access, while the PRO is designed for lock-down tilt.

2. Is the PLP available in a universal solution?

A Yes. Simply order a PLP-U to receive a universal interface bracket with the unit. The PLP can also be ordered as a custom mount. See ordering steps below.

3. Can I lock my display to the mount?

A Yes, Chief's exclusive Q-Latch Mounting System engages a latch around a Q-button, preventing the display from dislodging. Just add a padlock for security.

HOW TO ORDER

1. Determine which style mount will best suit your needs.

Note: flat panel displays smaller than 37" generally require a mount from our Small or Medium Flat Panel Display line. Check the cross-reference chart to verify.

2. For custom model number, look up your display in the cross-reference chart or on the website. Order PLP-xxxx, model number includes interface bracket.

3. For universal model number, order PLP-U, fits 90% of screen models.

4. Fax or e-mail your order to Customer Service at 877.894.6918 (Domestic) or 952.894.6918 (International), or orders@chiefmfg.com.

RECOMMENDED ACCESSORIES

PAGE

ENS Lateral Shift Extrusion for Video Walls	53
PAC-115 Steel Stud/Drywall Anchor Kit	52
PAC-125 Lateral Shift Accessory	53
PAC-126 Lateral Shift Accessory	53
PAC-251 CPU/DVD/VCR Universal Adapter	50
PAC-300 Side Speaker Adapter	50
PAC-301 Center Channel Speaker Adapter	50
PAC-400 90° Rotation Adapter	50

SPECIFICATIONS

Depth from Wall*	1-1/2" (38 mm)
Dimensions WxHxD	26" x 18-3/8" x 1-1/2" (660 x 467 x 38 mm)
Tilt	0°–15°
Lateral Shift	4" (102 mm)
Mounts on Studs	16", 20", 24" on-center
Color	Black
Weight Capacity	200 lbs (90.7 kg)

* Depth does not include interface bracket.

LARGE FLAT PANEL SWING ARM MOUNTS

CUSTOM OR UNIVERSAL

NEW

REACTION
SWING ARM MOUNTS

PWR™ SINGLE SWING ARM WALL MOUNT

A flexible solution for corporate and home entertainment applications for displays up to 125 lbs.

HE  25" EXTENSION

FAQ

1. What is the difference between the PWR and MWR?

A The PWR is designed for large flat panel displays 37"–50" and the MWR is designed for mid-size displays 26"–40". See cross reference information to determine, which model will best fit your display.

2. Is the PWR available as a universal solution?

A Yes. Simply order a PWR-U to receive a universal interface bracket with the unit. The PWR can also be ordered as a custom mount. See ordering steps below.

HOW TO ORDER

1. Determine how much extension is needed for your application.

Note: flat panel displays smaller than 37" generally require a mount from our Small or Medium Flat Panel Display line. Check the cross-reference chart to verify.

2. For custom model number, look up your display in the cross-reference chart or on the website. Order PWR-xxxx, model number includes interface bracket.

3. For universal model number, order PWR-U, fits 90% of screen models.

4. Fax or e-mail your order to Customer Service at 877.894.6918 (domestic) or 952.894.6918 (international), or orders@chiefmfg.com.

Mounting Guide System

Simple, one-man installation by hanging mount on two lag bolts.

Solid Steel Construction

Designed with cast and steel components for unmatched strength.

Q-Latch™ Mounting System

- Offers quick connect/disconnect
- Secures display with a latching flag
- Includes integrated security with the addition of a padlock
- Mounts in portrait or landscape position



Integrated Lateral Shift

Provides up to 4-1/2" (114 mm) of shift left or right of 16" centers.

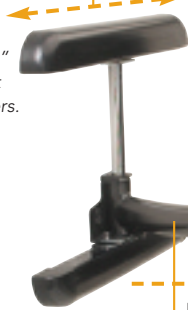

Mount in Portrait or Landscape Positions.

G-Force™ Gravity-Centered Tilt

Provides fingertip tilt +5° to -15°, and ±2-1/2° of roll adjustment.

Integrated Security

Add a padlock to ensure the display is secure.

Extends 25" (63 cm)

Aesthetic Design

- Curved arms provide a sleek look
- Available in black or silver to match screen

Multiple Ordering Options

- Custom interface for fast install
- Universal for stocking
- Wall mount without interface for pre-installation

Universal Option

Order PWR-U and get a PSB-U™ Universal Interface Bracket included.



CableTrac™ System

Channeled cable management provides quick and easy routing of cables.

Ultimate Flexibility

Extreme range of motion for every viewing angle.

SPECIFICATIONS

Depth From Wall*	3-3/8" (86 mm)
Extension from Wall	24-7/8" (63.2 cm)
Dimensions WxHxD	23-5/8" x 18" x 3-3/8" (60 x 45.7 x 8.6 cm)
Tilt/Roll	+5°, -15° / ±2-1/2°
Lateral Shift	4-1/2" (114 mm) Left/Right
Color	Silver or Black
Weight Capacity	125 lbs (56.7 kg)

* Depth does not include interface bracket.

RECOMMENDED ACCESSORIES

	PAGE
PAC-140 Q-Clamp for added security	52
PAC-150* Video Conferencing Shelf	54
PAC-251* CPU/DVD/VCR Universal Adapter	50
PAC-300* Side Speaker Adapter	50
PAC-301* Center Channel Speaker Adapter	50
PAC-400 90° Rotation Adapter*	50

* Confirm that the combined weight of the screen and accessory will not exceed the mount's rated capacity. Note: Swing arm mounts cannot be used with PAC-125, PAC-126 or ENS Lateral Shift accessories.

LARGE FLAT PANEL SWING ARM MOUNTS

CUSTOM OR UNIVERSAL

NEW

REACTION
SWING ARM MOUNTS

PNR™ DUAL ARM WALL MOUNT

Compact dual arm mount ideal for 37"– 60" screens. Offers advanced viewing angles for increased functionality.

HE  25" EXTENSION

■ Mounting Guide System

Simple, one-man installation by hanging mount on two lag bolts.

■ G-Force™ Gravity-Centered Tilt

Provides fingertip tilt +5° to -15°, and ±2-1/2° of roll adjustment.

■ Mount in Portrait or Landscape Positions.

■ Integrated Security

Add a padlock to ensure the display is secure.

■ Multiple Ordering Options

- Custom interface for fast install
- Universal for stocking
- Wall mount without interface for pre-installation

■ Universal Option

Order PNR-U and get PSB-U™ Universal Interface Bracket included.



■ Q-Latch™ Mounting System

- Offers quick connect/disconnect
- Secures display with a latching flag
- Includes integrated security with the addition of a padlock
- Mounts in portrait or landscape



■ Solid Steel Construction

Designed with cast and steel components for unmatched strength.

■ Integrated Lateral Shift

Provides up to 4-1/2" (114 mm) of shift left or right of 16" centers.

■ Post-Installation Height Adjustment

Provides up to 1-1/2" (38 mm) of flexibility.

■ Aesthetic Design

- Curved arms provide a sleek look
- Available in black or silver to match screen

■ CableTrac™ System

Channeled cable management provides quick and easy routing of cables.

Extends 25"
(63 cm)

■ Ultimate Flexibility

Extreme range of motion for every viewing angle.

FAQ

1. What is the difference between PNR and PDR?

A The PNR extends up to 24-7/8", while the PDR extends over 37" from the wall.

2. How do I know if my screen is too small to use with PNR?

A The PNR is designed for 37" screens and larger. To ensure the mount will be completely hidden, your screen width should be greater than 27-1/4" and screen height should be greater than 20".

3. Is the PNR available as a universal solution?

A Yes. Simply order a PNR-U to receive a universal interface bracket with the unit. The PNR can also be ordered as a custom mount. See ordering steps below.

HOW TO ORDER

1. Determine which style mount will best suit your needs.

Note: flat panel displays smaller than 37" generally require a mount from our Small or Medium Flat Panel Display line. Check the cross-reference chart to verify.

2. For custom model number, look up your display in the cross-reference chart or on the website. Order PNR-xxxx, model number includes interface bracket.

3. For universal model number, order PNR-U, fits 90% of screen models.

4. Fax or e-mail your order to Customer Service at 877.894.6918 (domestic) or 952.894.6918 (international), or orders@chiefmfg.com.

RECOMMENDED ACCESSORIES

PAGE

PAC-140 Q-Clamp for added security	52
PAC-150* Video Conferencing Shelf	54
PAC-251* CPU/DVD/VCR Universal Adapter	50
PAC-300* Side Speaker Adapter	50
PAC-301* Center Channel Speaker Adapter	50
PAC-400* 90° Rotation Adapter	50

*Confirm that the combined weight of the screen and accessory will not exceed the mount's rated capacity. Note: Swing-arm mounts cannot be used with PAC-125, PAC-126 or ENS Lateral Shift accessories.

SPECIFICATIONS

Depth	
From Wall*	3-1/4" (83 mm)
Extension from Wall	24-7/8" (63.2 cm)
Dimensions WxHxD	27-1/4" x 19-1/2" x 3-1/4" (69.2 x 49.5 x 8.3 cm)
Tilt/Roll	+5°, -15° / ±2-1/2°
Height Adjustment	1-1/2" (38 mm)
Lateral Shift	4-1/2" (114 mm) Left/Right
Color	Silver or Black
Weight Capacity	200 lbs (90.7 kg)

* Depth does not include interface bracket.

LARGE FLAT PANEL SWING ARM MOUNTS

CUSTOM OR UNIVERSAL

NEW

REACTION
SWING ARM MOUNTS

PDR™ DUAL SWING ARM WALL MOUNT

The ultimate home theater mount ideal for recessed applications, corners and viewing from all possible angles.

CU HE  37" EXTENSION

FAQ

1. What is the difference between the PDR and PNR?

A The PDR extends over 37" from the wall, while the PNR extends 24-7/8".

2. How do I know if my screen is too small to use with PDR?

A The PDR is designed for 42" screens and larger. To ensure the mount will be completely hidden, your screen width should be greater than 40" and screen height should be greater than 25".

3. Is the PDR available as a universal solution?

A Yes. Simply order a PDR-U to receive a universal interface bracket with the unit. The PDR can also be ordered as a custom mount. See ordering steps below.

HOW TO ORDER

1. Determine which style mount will best suit your needs.

Note: flat panel displays smaller than 37" generally require a mount from our Small or Medium Flat Panel Display line. Check the cross-reference chart to verify.

2. For custom model number, look up your display in the cross-reference chart or on the website. Order PDR-xxxx, model number includes interface bracket.

3. For universal model number, order PDR-U, fits 90% of screen models.

4. Fax or e-mail your order to Customer Service at 877.894.6918 (domestic) or 952.894.6918 (international), or orders@chiefmfg.com.

■ Solid Steel Construction

Designed with cast and steel components for unmatched strength.

■ Integrated Lateral Shift

Provides up to 4-1/2" of shift (114 mm) left or right of 16" centers.

■ Post-Installation Height Adjustment

Provides up to 3" (76 mm) of flexibility.

■ Mounting Guide System

Simple, one-man installation by hanging mount on two lag bolts.

■ Q-Latch™ Mounting System

- Offers quick connect/disconnect
- Secures display with a latching flag
- Includes integrated security with the addition of a padlock

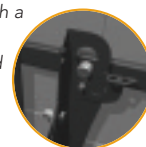

■ Mount in Portrait or Landscape.

■ G-Force™ Gravity Centered Tilt

Provides fingertip tilt +5° to -15°, and ±2-1/2° of roll adjustment.

■ Integrated Security

Add a padlock to ensure the display is secure.

■ Aesthetic Design

- Curved arms provide a sleek look
- Available in black or silver to match screen

■ Multiple Ordering Options

- Custom interface for fast install
- Universal for stocking
- Wall mount without interface for pre-installation

■ Universal Option

Order PDR-U and get a PSB-U™ Universal Interface Bracket included.

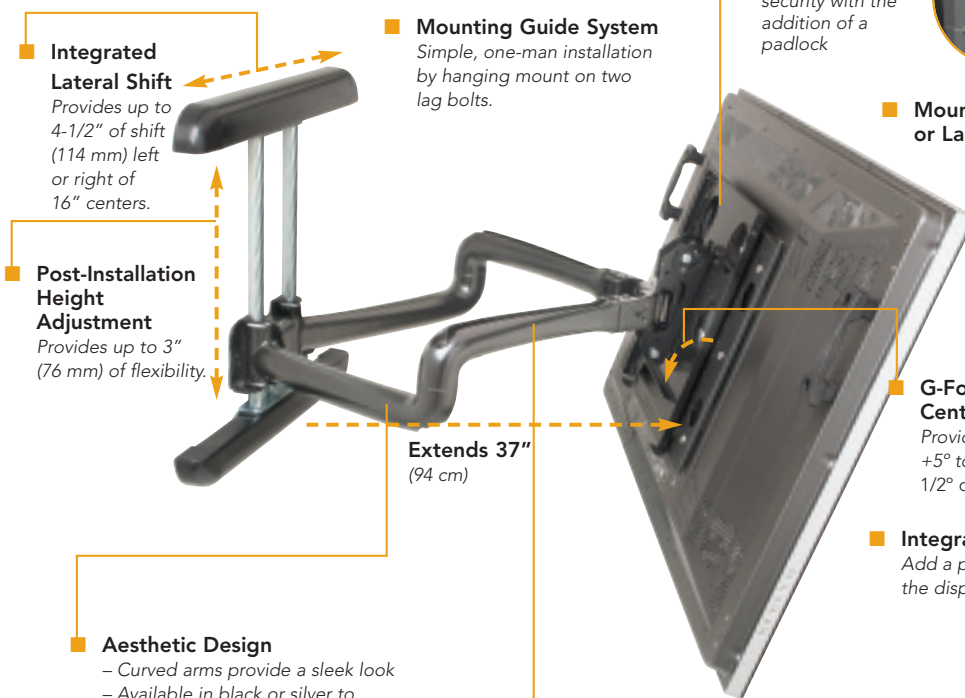

SPECIFICATIONS

Depth From Wall*	2-7/8" (74 mm)
Extension from Wall	37-3/8" (95 cm)
Dimensions WxHxD	39-1/2" x 24-1/3" x 2-7/8" (100.3 x 61.8 x 7.4 cm)
Tilt/Roll	+5°, -15° / ±2-1/2°
Height Adjustment	3" (76 mm)
Lateral Shift	4-1/2" (114 mm) Left/Right
Color	Silver or Black
Weight Capacity	200 lbs (90.7 kg)

* Depth does not include interface bracket.

RECOMMENDED ACCESSORIES

	PAGE
PAC-140 Q-Clamp for added security	52
PAC-150* Video Conferencing Shelf	54
PAC-251* CPU/DVD/VCR Universal Adapter	50
PAC-300* Side Speaker Adapter	50
PAC-301* Center Channel Speaker Adapter	50
PAC-400* 90° Rotation Adapter	50

*Confirm that the combined weight of the screen and accessory will not exceed the mount's rated capacity. Note: Swing-arm mounts cannot be used with PAC-125, PAC-126 or ENS Lateral Shift accessories.



LARGE FLAT PANEL CEILING MOUNTS

CUSTOM OR UNIVERSAL

FAQ

1. Do I need to order a separate interface bracket?

A No, each mount includes an interface bracket. Determine which part number will accommodate your display by looking up the manufacturer in the cross-reference chart.

2. Do I need additional accessories for my installation?

A Yes, the PCM requires a ceiling plate. An extension column may be needed for additional drop from the ceiling.

HOW TO ORDER

1. Determine which style mount will best suit your needs.

Note: flat panel displays smaller than 37" generally require a mount from our Small or Medium Flat Panel Display line. Check the cross-reference chart to verify.

2. For the correct model number, look up your display in the cross-reference chart or on the website. Model number includes interface bracket.

3. Determine the correct ceiling plate accessory and additional extension column for your installation.

4. Fax or e-mail your order to Customer Service at 877.894.6918 (domestic) or 952.894.6918 (international), or orders@chiefmfg.com.

PCM™ SINGLE CEILING MOUNT

Strong, innovative mount that hangs the display with the natural center of gravity. Perfect for digital signage, information displays, airports, bars and restaurants.



- Angled column provides gravity-centered positioning for unmatched stability**
- Easily accommodates different screen sizes!**
Provides 5" (127 mm) of height adjustment to fit multiple display sizes.
- Mount in Portrait or Landscape**
- Flexible Installation**
Display installs in portrait or landscape positions.
- Wrench-adjustable tilt locks display at any angle**
- Cable Management**
Provides easy cable management through mount and extension column by adding an optional CMA-330 Accessory.
- Includes PAC-140 Q-Clamp Accessory.**
- USA-1 allows VCRs and other accessories to be mounted on a shelf attached to the PCM mount. (USA-1 sold separately)**
- Q-Latch™ Mounting System**
 - Offers quick connect/disconnect
 - Secures display with a latching flag
 - Includes integrated security with the addition of a padlock
 - Mounts in portrait or landscape positions
- Multiple Ordering Options**
 - Custom interface for fast install
 - Universal for stocking
 - Wall mount without interface for pre-installation
- Universal Option**
Order PCM-U and get a PSB-U™ Universal Interface Bracket included.

SPECIFICATIONS

Height Adjustment	5" (127 mm)
Dimensions WxHxD	Varies
Tilt/Roll/Yaw	+5°, -25°/3°/360°
Color	Black
Weight Capacity	175 lbs (79.5 kg)

RECOMMENDED ACCESSORIES

	PAGE
CMA-100 8" (203 mm) Ceiling Plate with Attached Adjustable 1-1/2" NPT Column	53
CMA-115 6" (154 mm) Ceiling Plate with 1-1/2" NPT Opening	53
CMA-351 Heavy-Duty Swivel Adapter	54
PAC-251* CPU/DVD/VCR Universal Adapter	50
PAC-300* Side Speaker Adapter	50
PAC-400 90° Rotation Adapter	50
USA-1 13" x 13" (330 x 330 mm) Accessory Shelf	54

*Confirm that the combined weight of the screen and accessory will not exceed the mount's rated capacity. For additional accessories for this product, see page 50-54.

LARGE FLAT PANEL CEILING MOUNTS

CUSTOM OR UNIVERSAL

PDC™ DUAL CEILING MOUNT

Advanced back-to-back display functionality for public transportation, digital signage and data presentation in high traffic zones.



Allows stacking of multiple displays

Simply attach an additional 2" NPT pipe to bottom of unit to stack additional displays.

Flexible Installation

- Displays install in portrait or landscape positions
- Some tilt is lost in portrait position for 60" and larger screens

Gravity-centered tilt provides quick adjustment to any desired angle

Even for displays mounted well above eye level!

Multiple Ordering Options

- Custom interface for fast install
- Universal for stocking
- Wall mount without interface for pre-installation

Universal Option

Order PDC-U and get a PSB-U™ Universal Interface Bracket included.



Clean Cable Management

Provides easy cable management through mount and extension column with optional CMA-332 Accessory.

Column not included.

Includes PAC-140 Q-Clamp Accessory.

Mount in Portrait or Landscape.

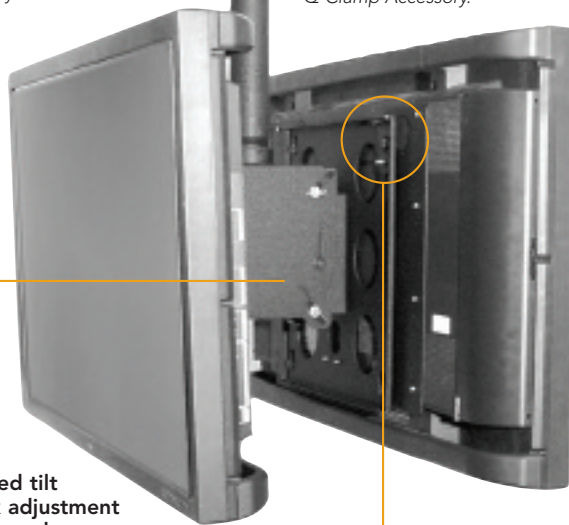

Q-Latch™ Mounting System

- Offers quick connect/disconnect
- Secures display with a latching flag
- Includes integrated security with the addition of a padlock
- Mounts in portrait or landscape positions

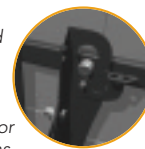

FAQ

1. Do I need to order a separate interface bracket?

A No, each mount includes an interface bracket. Determine which part number will accommodate your display by looking up the manufacturer in the cross-reference chart.

2. How does the gravity-centered axis point work with the tilt adjustment?

A Chief's exclusive design counteracts the weight of the display, allowing for the hand tilt adjustment to work with the display's weight and balance on its own center of gravity.

3. Do I need additional accessories for my installation?

A Yes, the PDC requires a ceiling plate and extension column to mount from the ceiling. To mount two different large flat panel display models, order a separate PSB interface bracket for the different display.

HOW TO ORDER

1. Determine which style mount will best suit your needs.

Note: flat panel displays smaller than 37" generally require a mount from our Small or Medium Flat Panel Display line. Check the cross-reference chart to verify.

2. For the correct model number, look up your display in the cross-reference chart or on the website. Model number includes interface brackets.

3. Determine the correct ceiling plate accessory for your installation.

4. Fax or e-mail your order to Customer Service at 877.894.6918 (domestic) or 952.894.6918 (international), or orders@chiefmfg.com.

RECOMMENDED ACCESSORIES

PAGE

CMA-210 8" (203 mm) Ceiling Plate with 2" NPT Coupler	53
CMA-251 2" to 1-1/2" NPT Adapter/Reducer	54
CMA-260 8" (203 mm) Ceiling Plate and Adjustable 2" NPT Column	53
CMA-332 Offset Ceiling Plate with 2" Coupler	53
PAC-251* CPU/DVD/VCR Universal Adapter	50
PAC-300* Side Speaker Adapter	50
PAC-301* Center Channel Speaker Adapter	50
PAC-302* Center Channel Speaker Shelf	50
PAC-400* 90° Rotation Adapter	50

*Confirm that the combined weight of the screen and accessory will not exceed the mount's rated capacity.

SPECIFICATIONS

Dimensions	
WxHxD	Varies
Tilt/Roll/Yaw	+5°, -15°/3°/360°
Color	Black
Weight	
Capacity	300 lbs (136 kg)

LARGE FLAT PANEL TRUSS & POLE MOUNTS

CUSTOM OR UNIVERSAL

FAQ

1. Do I need to order a separate interface bracket?

A No, each mount includes an interface bracket. Determine which part number will accommodate your display by looking up the manufacturer in the cross-reference chart.

2. Do the pole/truss clamps come with the mount?

A No, the appropriate size clamps must be ordered separately.

3. Can I mount small flat panel displays to the pole or truss?

A Yes, if you have a round pole 1-1/2"–2" OD (refer to the FSP pole mount). If you have a larger pole, square pole or truss system, order the appropriate TPA mounts (TPA-110, TPA-111, TPA-112).

HOW TO ORDER

- Determine which style mount will best suit your needs.
- For the correct model number, look up your display in the cross-reference chart or on the website. Model number includes interface bracket.
- Determine which clamp size you need for your truss or pole(s) and order the appropriate TPK Clamp Kit. If you don't see the clamp size you need, you can purchase your own U-Bolt clamps.
- Fax or e-mail your order to Customer Service at 877.894.6918 (domestic) or 952.894.6918 (international), or orders@chiefmfg.com.

TPS™ FIXED TRUSS & POLE MOUNT

Quick, easy and versatile! Perfect for exhibit and retail applications using truss systems or poles.



Easy to install!

Fits vertical or horizontal truss systems up to 14" (356 mm) OD.

Ultra Low-Profile

Sits snugly against truss or poles for an integrated look!

Solid Steel Construction.

Multiple Ordering Options

- Custom interface for fast install
- Universal for stocking
- Wall mount without interface for pre-installation

Universal Option

Order TPS-U and get a PSB-U™ Universal Interface Bracket included.

■ Display installs in portrait or landscape positions.

■ Accommodates a wide range of truss and pole dimensions to make a custom installation.

Q-Latch™ Mounting System

- Offers quick connect/disconnect
- Secures display with a latching flag
- Includes integrated security with the addition of a padlock

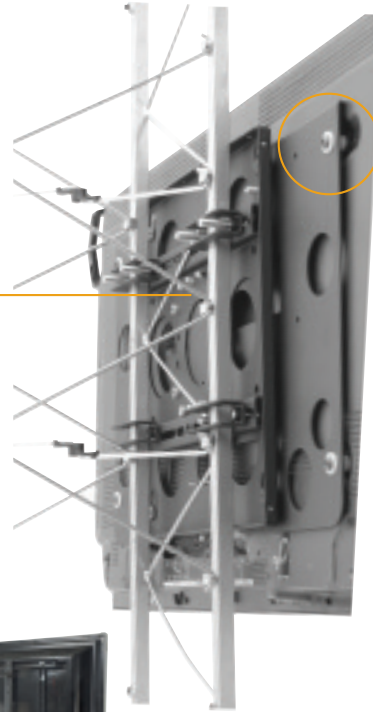

POLE AND TRUSS KITS

Order one of the following kits with your mount:

TPK-1 Pole Kit	TPK-2 Pole Kit	TPK-3 Truss Kit	TPK-4 Truss Kit	TPK-5 Truss Kit
Kit includes: 2 clamps for 1"–2" (25–51 mm) OD round or square poles	Kit includes: 2 clamps for 2"–3" (51–76 mm) OD round or square poles	Kit includes: 4 clamps for 1" (25 mm) or smaller OD round or square truss	Kit includes: 4 clamps for 1"–2" (25 - 51 mm) OD round or square truss	Kit includes: 4 clamps for 2"–3" (51 - 76 mm) OD round or square truss

SPECIFICATIONS

Dimensions WxHxD	16-3/16" x 16-11/16" x 13/16" (410 x 424 x 21 mm)
Color	Black
Weight Capacity	150 lbs (68.2 kg)

RECOMMENDED ACCESSORIES

	PAGE
PAC-251* CPU/DVD/VCR Universal Adapter	50
PAC-300* Side Speaker Adapter	50
PAC-301* Center Channel Speaker Adapter	50
PAC-400 90° Rotation Adapter	50
TPA-100** Finishing Cover for TPS Fixed Mount	54
TPA-112 Small Flat Panel Fixed Truss & Pole Mount	54

*Confirm that the combined weight of the screen and accessory will not exceed the mount's rated capacity.
**Available for pole mounts only.

LARGE FLAT PANEL TRUSS & POLE MOUNTS

CUSTOM OR UNIVERSAL

TPM™ TILT-ADJUSTABLE POLE MOUNT

Innovative solution for digital signage applications where tilt is needed for angled viewing. TPP Tilt-Adjustable Truss Mount is also available.



Quick Adjustments

- Gravity-centered tilt provides quick adjustment to any desired angle
- Install in portrait position and use tilt adjustment for side-to-side pivot

Q-Latch™ Mounting System

- Offers quick connect/disconnect
- Secures display with a latching flag
- Includes integrated security with the addition of a padlock



Multiple Ordering Options

- Custom interface for fast install
- Universal for stocking
- Wall mount without interface for pre-installation

Universal Option

Order TPM-U or TPP-U and get PSB-U™ Universal Interface Bracket included.



■ Use with vertical or horizontal poles.

■ Align multiple displays with ease
Preset tilt locking points (0°, 5°, 10°, 15°).

■ Install in portrait or landscape positions
This feature is compatible with poles up to 6" (152 mm) OD; clamps available up to 3" (76 mm).

■ Sturdy steel construction for demanding installations.

POLE AND TRUSS KITS

Order one of the following kits with your mount:

TPK-1 Pole Kit	TPK-2 Pole Kit	TPK-3 Truss Kit	TPK-4 Truss Kit	TPK-5 Truss Kit
Kit includes: 2 clamps for 1"–2" (25–51 mm) OD round or square poles	Kit includes: 2 clamps for 2"–3" (51–76 mm) OD round or square poles	Kit includes: 4 clamps for 1" (25 mm) or smaller OD round or square truss	Kit includes: 4 clamps for 1"–2" (25 - 51 mm) OD round or square truss	Kit includes: 4 clamps for 2"–3" (51 - 76 mm) OD round or square truss

FAQ

1. Do I need to order a separate interface bracket?
A No, each mount includes an interface bracket. Determine which part number will accommodate your display by looking up the manufacturer in the cross-reference chart.
2. Do the pole/truss clamps come with the mount?
A No, the appropriate size clamps must be ordered separately.
3. Can I mount small flat panel displays to the pole or truss?
A Yes, if you have a round pole 1-1/2"– 2" OD (refer to the FSP pole mount). If you have a larger pole, square pole or truss system, order the appropriate TPA mounts (TPA-110, TPA-111, TPA-112).

HOW TO ORDER

1. Determine which style mount will best suit your needs.
2. For the correct model number, look up your display in the cross-reference chart or on the website. Model number includes interface bracket.
2. Determine which clamp size you need for your truss or pole(s) and order the appropriate TPK Clamp Kit. If you don't see the clamp size you need, you can purchase your own U-Bolt clamps.
4. Fax or e-mail your order to Customer Service at 877.894.6918 (domestic) or 952.894.6918 (international), or orders@chiefmfg.com.

RECOMMENDED ACCESSORIES

PAGE

PAC-251* CPU/DVD/VCR Universal Adapter	50
PAC-300* Side Speaker Adapter	50
PAC-301* Center Channel Speaker Adapter	50
PAC-400 90° Rotation Adapter	50
TPA-105** Finishing Cover for TPM Tilt-Adjustable Mount	54
TPA-110 Small Flat Panel Tilt-Adjustable Pole Mount	54
TPA-111 Small Flat Panel Tilt-Adjustable Truss Mount	54

* Confirm that the combined weight of the screen and accessory will not exceed the mount's rated capacity.

**Available for pole mounts only.

SPECIFICATIONS

Model:	TPM	TPP
Dimensions WxHxD	16-3/16" x 16-11/16" x 3-3/8" (411 x 424 x 86 mm)	16-3/16" x 16-11/16" x 4-1/16" (411 x 424 x 103 mm)
Tilt/Roll/Yaw	15°/4°/360°	15°/4°/0°
Color	Black	Black
Weight Capacity	150 lbs (68 kg)	150 lbs (68 kg)

LARGE FLAT PANEL STANDS AND CARTS

CUSTOM OR UNIVERSAL

FAQ

1. Do I need to order a separate interface bracket?

A No, the stands include an interface bracket. Determine which part number will accommodate your display by looking up the manufacturer in the cross-reference chart.

2. What is the maximum screen size that can be used?

A The maximum outside height of the screen must not exceed 32". Both models are designed to accommodate most 32"-50" displays.

HOW TO ORDER

1. Confirm that your display fits the maximum outside dimensions of the stand.
2. For the correct model number, look up your display in the cross-reference chart or on the website. Model number includes interface bracket.
3. Fax or e-mail your order to Customer Service at 877.894.6918 (domestic) or 952.894.6918 (international), or orders@chiefmfg.com.

PTS™/PSS™ TABLE STANDS

Stylish tabletop installations for residential, commercial and business applications.

HE

PTS Fixed Table Stand



■ Sturdy, low-profile base

■ Five height adjustments in 1" (25 mm) increments accommodate different display heights up to 32".

■ Q-Latch™ Mounting System

- Offers quick connect/disconnect
- Secures display with a latching flag
- Includes integrated security with the addition of a padlock



■ Multiple Ordering Options

- Custom interface for fast install
- Universal for stocking

■ Universal Option

Order PTS-U or PSS-U and get a PSB-U™ Universal Interface Bracket included.



■ Built-In Cable Management

Two options for an easy, clean installation.

■ Height adjustment of 5" (127 mm) to accommodate different display heights up to 50".

PSS Swivel Table Stand

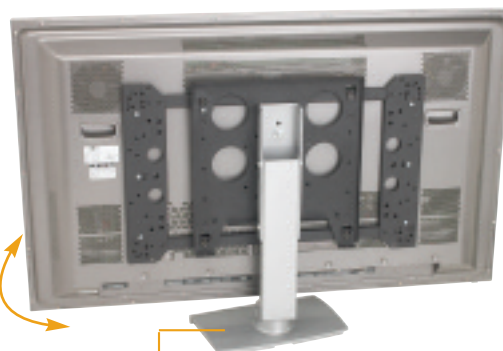

■ Smooth swivel 45° in either direction
Optional stops at 15°, 25° and 35°.

■ Free-standing with bolt-down capability for permanent installations and security.

SPECIFICATIONS

Model	PTS	PSS
Height Adjustment	5" (127 mm)	5" (127 mm)
Dimensions WxHxD	24" x 3/4" x 12" (610 x 19 x 305 mm)	14-3/8" x 3-1/4" x 9-5/6" (365 x 83 x 236 mm)
Color	Black	Black or Silver
Weight Capacity	100 lbs (45.4 kg)	150 lbs (68 kg)

Note: Screen height cannot exceed 32".

RECOMMENDED ACCESSORIES

Accessory	PAGE
PAC-110* Aesthetic Cover Kit	54
PAC-140 Q-Clamp for added security	52
PAC-150 Video Conferencing Shelf	54

* Not compatible with the PTS.

LARGE FLAT PANEL STANDS AND CARTS

CUSTOM OR UNIVERSAL

PFS™ FLOOR STAND

A solid, low-profile solution for digital signage and corporate presentations.



■ Unique design

Allows screen to be mounted at any height on the post.

■ Q-Latch™ Mounting System

- Offers quick connect/disconnect
- Secures display with a latching flag
- Includes integrated security with the addition of a padlock



■ Available in 3 heights:

- PFS 2160- 60" (152 cm)
- PFS 2172- 72" (183 cm)
- PFS 2184- 84" (213 cm)

■ Video Conferencing Shelf Compatible.



■ Display installs in portrait or landscape positions.

■ Ability to stack multiple displays

Depending on post length, display height and weight capacity.

PAC-100 Accessory Shelf (not included)

■ Presenter-friendly base reduces trip hazards.

■ Universal Option

Order PTS-U or PSS-U and get a PSB-U™ Universal Interface Bracket included.



FAQ

1. Do I need to order a separate interface bracket?

A Yes, find the make and model of your display in the cross-reference chart. You will need one PSB bracket for each display.

2. Can multiple displays be stacked on one stand?

A Yes, depending on the length of the posts and the height of the display. The total weight must not exceed 100 lbs (45.5 kg).

HOW TO ORDER

1. Determine the post length that will best fit your application.
2. Find the interface bracket you will need by looking up the manufacturer and model number of your display in the cross-reference chart. You will need one interface bracket per display.
3. Decide which shelves and accessories you need.
3. Fax or e-mail your order to Customer Service at 877.894.6918 (domestic) or 952.894.6918 (international), or orders@chiefmfg.com.

RECOMMENDED ACCESSORIES

PAGE

PSB Bracket* (Required)

MAC-160 Medium Flat Panel Display Accessory Bracket	54
PAC-100 Accessory Shelf	54
PAC-105 Xtreme Stabilizer Kit	54
PAC-140 Q-Clamp	52
PAC-150 Video Conferencing Shelf	54
PAC-251 CPU/DVD/VCR Universal Adapter	50
PAC-300 Side Speaker Adapter	50
PAC-301 Center Channel Speaker Adapter	50
PAC-400 90° Rotation Adapter	50

*Refer to Chief's Cross Reference Chart, available at www.chiefmfg.com.

SPECIFICATIONS

Height Adjustment	Varies
Dimensions WxD	36" x 30" (91.4 x 76.2 cm)
Color	Black
Weight Capacity	100 lbs (45.5 kg)

LARGE FLAT PANEL STANDS AND CARTS

CUSTOM OR UNIVERSAL

FAQ

- Do I need to order a separate interface bracket?**
A Yes, find the make and model of your display in the cross-reference chart. You will need one PSB bracket for each display.
- Can multiple displays be stacked on one stand?**
A Yes, order additional PAC head assemblies and PSB brackets to create the look you want. The total weight of the displays must not exceed 300 lbs (136.4 kg).
- Can I change my PFB stand into a cart or vice versa?**
A Yes, if you have a PFB, order the PAC-148 cart base with casters. If you already own a PTC cart, order the correct PAC accessory base to convert to a stand.

HOW TO ORDER

- Determine the post length, head assembly and base style that will best fit your application.
- Find the interface bracket you will need by looking up the manufacturer and model number of your display in the cross-reference chart. You will need one interface bracket per display.
- Fax or e-mail your order to Customer Service at 877.894.6918 (domestic) or 952.894.6918 (international), or orders@chiefmfg.com.

PFB™ DUAL POLE FLOOR STAND

A heavy-duty, versatile option for rental, staging and digital signage applications.

HE

Custom Solution

Multiple configurations and modular components to fit your application needs.

Sturdy Design

Allows for stacking multiple screens using additional head assembly accessories.

3 Post Lengths:

- PFB 2057– 57" (145 cm)
- PFB 2069– 69" (175 cm)
- PFB 2084– 84" (213 cm)

Chrome finished poles for aesthetics.

Flexible Height Adjustment

Install a single screen at any point on the pole.

Display installs in portrait or landscape positions.

Q-Latch™ Mounting System

- Offers quick connect/disconnect
- Secures display with a latching flag
- Includes integrated security with the addition of a padlock

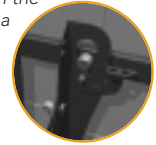

Available as a single screen or dual screen base.

Easy disassembly of base for shipping or handling

Can also be ordered separately for use on PTC cart.

Universal Option

Order PTS-U or PSS-U and get a PSB-U™ Universal Interface Bracket included.



Pole	Single Display	Dual Display
57" (145 cm)	PFB-2057SB	PFB-2057DB
69" (175 cm)	PFB-2069SB	PFB-2069DB
84" (213 cm)	PFB-2084SB	PFB-2084DB

SPECIFICATIONS

Height Adjustment	Varies
Dimensions WxHxD	Varies
Color	Black w/ chrome posts
Weight Capacity	300 lbs (136.4 kg)

RECOMMENDED ACCESSORIES

PAGE

PSB* (Required)

PAC-140 Q-Clamp	52
PAC-141 Back-to-Back Display Head Assembly	54
PAC-142 Single Display Head Assembly	54
PAC-143 Back-to-Back Small Flat Panel Head Assembly	54
PAC-150 Video Conferencing Shelf	54
PAS-1 18" x 24" (45.7 x 61 cm) Accessory Shelf	54
P-45 45" (114 mm) Chrome Post	54
USA-1 13" x 13" (330 x 330 mm) Accessory Shelf	54

*Refer to Chief's Cross-Reference Chart, available at www.chiefmfg.com.

For additional accessories for this product, see page 56.

LARGE FLAT PANEL STANDS & CARTS

CUSTOM OR UNIVERSAL

PTC™ MOBILE CART

A sleek, rolling solution that is perfect for video conference, boardrooms and digital signage applications.



Note: PAC-140 Q-Clamp Accessory included.

Flexible Height Adjustments

Sturdy Design
Allows for stacking multiple screens using additional accessories.

Flexible Installation
– Install in portrait or landscape positions
– 14" (356 mm) Q-Latch pattern makes for a versatile solution

Universal Option
Order PTS-U or PSS-U and get a PSB-U™ Universal Interface Bracket included.



(PAS-1 Equipment Shelf not included)

Q-Latch™ Mounting System

- Offers quick connect/disconnect
- Secures display with a latching flag
- Includes integrated security with the addition of a padlock

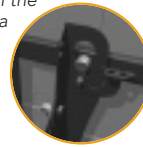

Three Post Lengths

- PTC 2041- 45" (114 cm), max screen height: 60"
- PTC 2042- 57" (145 cm), max screen height: 72"
- PTC 2043- 69" (175 cm), max screen height: 84"

Total-Lock™ Brakes
Four 4" (102 mm) swivel casters.

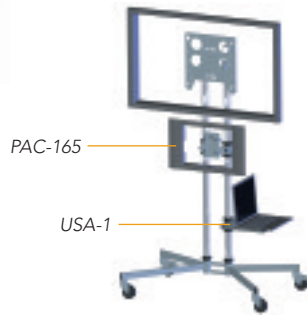

PAC-165

USA-1

PTC is compatible with multiple accessories, like the PAC-165 and USA-1, to customize your cart and provide a place for equipment. (Accessories sold separately)

FAQ

- Do I need to order a separate interface bracket?**
A Yes, find the make and model of your display in the cross-reference chart. You will need one PSB bracket for each display.
- Can multiple displays be stacked on one stand?**
A Yes, depending on the length of the cart posts and the height of the display. The total weight must not exceed 150 lbs (68.8 kg).
- Can I change my PTC cart into a stand or vice versa?**
A Yes, if you already own a PTC cart order the correct PAC accessory base to meet your needs. If you have a PFB, order the PAC-148 cart base with casters.
- Are leveling feet available?**
A Yes, the casters are removable. Order the PTCLF accessory, which includes a set of four heavy-duty, 3" (76.2 mm) diameter leveling feet.

HOW TO ORDER

- Determine the post length and screen height you need for your application.
- Find the correct interface bracket for your display by looking in the cross-reference chart.
- Decide which accessories you will need for your installation.
- Fax or e-mail your order to Customer Service at 877.894.6918 (domestic) or 952.894.6918 (international), or orders@chiefmfg.com.

RECOMMENDED ACCESSORIES

PAGE

PSB* (Required)

PAC-150 Video Conferencing Shelf	54
PAC-165 Small Flat Panel Display Accessory Bracket	54
PAS-1 18" x 24" (45.7 x 61 cm) Equipment Shelf	54
PTCLF Leveling Feet	54
USA-1 13" x 13" (330 cm x 330 mm) Accessory Shelf	54

*Refer to Chief's Cross Reference Chart, available at www.chiefmfg.com.
For additional accessories for this product, see pages 54 – 56.

SPECIFICATIONS

Height Adjustment	Varies
Dimensions WxD	45" x 30-1/2" (114 x 77.5 cm)
Tilt	+5°, -15°
Color	Black w/chrome posts
Weight Capacity	150 lbs (68.8 kg)

LARGE FLAT PANEL STANDS & CARTS

CUSTOM SOLUTION

FAQ

- Do I need to order a separate interface bracket?**
A Yes, find the make and model of your display in the cross-reference chart. You will need one PSB bracket for each display.
- What is the difference between the PPC and PPD?**
A The PPC is for a single display up to 61". The PPD is for mounting two 42" displays side-by-side.
- Does the PPC/PPD include cable management?**
A Yes, cables from equipment on the optional shelves can be routed through the side uprights.
- What is the accessory equipment shelf spacing and distance?**
A There are four sets of shelf mounting holes at 6" (152 mm) intervals.
- Are leveling feet available?**
A Yes, the casters are removable. Order the PTCLF accessory, which includes a set of four heavy-duty 3" (76 mm) diameter leveling feet.

HOW TO ORDER

- Confirm that your display fits the maximum equipment size of the cart.
- Find the interface bracket you will need by looking up the manufacturer and model number of your display in the cross-reference chart. If ordering the PPD, you will need two PSB brackets.
- Fax or e-mail your order to Customer Service at 877.894.6918 (domestic) or 952.894.6918 (international), or orders@chiefmfg.com.

PPC™ CONFERENCING & PRESENTERS CART

Designed specifically for presentations to provide easy, mobile video conferencing and a streamlined solution. PPD Dual Display Presenters Cart also available.



- Built-In Cable Management**
For a clean, professional installation.
- Assembly Shelf Options:**
 - PAC-150 Video Conferencing Shelf
 - PAC-100 Smoked Acrylic Assembly Shelf
- Q-Latch™ Mounting System**
 - Offers quick connect/disconnect
 - Secures display with a latching flag
 - Includes integrated security with the addition of a padlock



- Display installs in portrait and landscape views.**

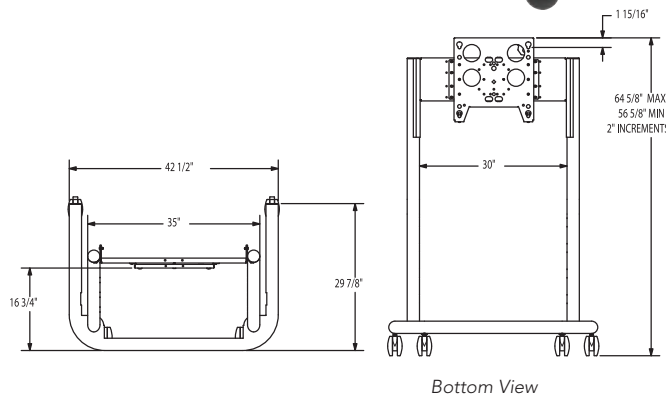

SPECIFICATIONS

Display Height Adjustment	45" – 59" (in 2" increments)
Dimensions WxHxD	42-3/8" x 29-3/4" (108 x 75.6 cm)
Color	Black
Weight Capacity	200 lbs (90.9 kg)

RECOMMENDED ACCESSORIES

ACCESSORY	PAGE
PSB* (Required)	
PAC-150 Video Conferencing Shelf	54
PAC-300** Side Speaker Adapter	54
PAC-301** Center Channel Speaker Adapter	54
PAC-302** Center Speaker Shelf	54
PAS-100 Smoked Acrylic Accessory Shelf	54
PTCLF Leveling Feet	54

*Refer to Chief's Cross Reference Chart, available at www.chiefmfg.com.
 **Confirm combined weight.

LARGE FLAT PANEL NOTES

NOTES:

LARGE FLAT PANEL ACCESSORIES

CPU/DVD/VCR MOUNT ACCESSORY

PAC™-251 CPU/DVD/VCR UNIVERSAL ADAPTER

- Integrate a CPU, DVD player or VCR into installations
- Easily adapts to Chief's Q-Latch™ Mounting System
- Securely hides the device behind the display
- Allows easy access to drives and input/output connections
- Adds 4" (102 mm) to installation depth and 14 lbs (6.4 kg) not including CPU/DVD/VCR (*be sure added weight does not exceed the weight capacity of the mount*)
- Fits equipment dimensions: 5-1/8"–17-5/8" W x 1-1/2"–3-1/4" H x 3-1/2"–15-1/2" D (130–450 mm W x 38–83 mm H x 89–394 mm D)

Note: Not compatible with PSM.



NEW

PAC™-252 CPU UNIVERSAL ADAPTER*

- Easily adapts to Chief's Q-Latch™ Mounting System
- Securely hides the device behind the display
- Allows easy access to drives and input/output connections
- Fits larger CPU Models including ASUS Pundit-R and NEC Bluefire VC
- Includes security hardware and ships fully assembled for easy installation
- Dimensions (HxWxD): 20" x 17.58" x 5.72" (50.8 cm x 44.6 cm x 145 mm)

* Center of Gravity tilt mechanisms must be locked down.

Notes: – Not compatible with PSM.

– Adds 20 lbs (9 kg) to the installation.



SPEAKER ACCESSORIES

NEW

PAC™-Y1 YAMAHA YSP-1 CENTER CHANNEL SPEAKER ADAPTER

- Attaches conveniently between the display and wall mount
- Uses Q-Latch™ Mounting System for easy installation
- Can be used with any Chief mount with a 14" (356 mm) square pattern
- Includes 5" (127 mm) of height adjustment

Note: Not compatible with PSM.



PAC™-300 SIDE SPEAKER ADAPTER

- Easily attaches side speakers to most Chief large flat panel mounts
- Uses Q-Latch™ Mounting System for easy installation
- Provides width and height adjustment for different size speakers', combined width of display and one speaker cannot exceed 59-1/2" (151 cm)
- Bracket offers 2" (51 mm) of total speaker adjustment
- Adds 20 lbs (9.1 kg) to installation (*be sure added weight does not exceed the weight capacity of the mount*)

Note: Not compatible with PSM.



PAC™-301 DIRECT ATTACH CENTER CHANNEL SPEAKER ADAPTER

- Attaches conveniently between the display and wall mount
 - Uses Q-Latch™ Mounting System for easy installation
 - Can be used with any Chief mount with a 14" (356 mm) square pattern
 - Includes 5" (127 mm) of height adjustment
 - Several slots on the back accommodate different speaker sizes
 - Can be used with the PAC-300 for further customization (sold separately)
- Notes – Not compatible with PSM
– Adds 10 lbs (4.54 kg) to the installation



PAC™-302 CENTER CHANNEL SPEAKER SHELF

- Can be used with center channel speakers or other equipment with max depth of 7-1/2" (191 mm)
 - Attaches conveniently between the display and wall mount
 - Uses Q-Latch™ Mounting System for easy installation
 - Can be used with any Chief mount with a 14" (356 mm) square pattern
 - Includes 5" (127 mm) of height adjustment
 - Several slots on the back accommodate different speaker sizes
 - Can be used with the PAC-300 for further customization (sold separately)
- Note: Not compatible with PSM.

PAC™-390 CUBE SYSTEM ADAPTER

- Allows any Chief static or tilt mount to attach directly to office cube systems
 - The perfect solution for government and military applications where cubicle systems are quickly constructed and frequently changed
 - Quick installation and movement
 - Adjusts to cube wall depths up to 3-13/16" (97 mm)
 - Adds 9/16" (14 mm) depth to overall installation
 - Weight Capacity: 175 lbs (79.5 kg)
- Note: Adds 10 lbs (4.54 kg) to the installation



PAC™-400 90° ROTATION ADAPTER

- Easily rotates large flat panel displays from portrait to landscape positions without removing the screen
 - Compatible with Chief's Q-Latch™ Mounting System
 - Adjustable rotation friction can easily be set to customer preference for fingertip control
 - Cable management system
 - Bracket adds 19 lbs (41.8 kg) and 1-1/16" (27 mm) depth to installation
 - Integrated security
- Note: Not compatible with PSM.

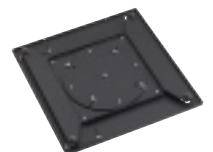

LARGE FLAT PANEL ACCESSORIES

STRUCTURAL ADAPTERS

CMA™-300 PIPE CLAMP

- Clamps onto a 1-7/8"–3-1/2" (48–89 mm) horizontal pipe
- Allows cable access
- Attaches to 1-1/2" NPT threaded extension column
- Weight Capacity: 300 lbs (136.4 kg)



CMA™-360 I-BEAM CLAMP

- Adapts a 1-1/2" NPT column to I-beam truss from 2-5/16"–12" (59–305 mm) wide
- Weight Capacity: 250 lbs (113.6 kg)



CMA™-362 C-CLAMP

- Great for mounting equipment in exhibit booths
- Clamps to any structure up to 2-3/4" (70 mm) OD, including 2" x 4" (51–102 mm) structures
- Attaches to a 1-1/2" NPT extension column
- Quick, versatile installation
- Cable management through column
- Weight Capacity: 250 lbs (113.6 kg)



CMA™-365 TRUSS CEILING ADAPTER

- Adapts a 1-1/2" threaded extension column to square, round or rectangular I-beam truss up to 3" (76 mm) in diameter
- Weight Capacity: 250 lbs (113.6 kg)



CMA™-366 ARCHITECTURAL SPANNING ADAPTER

- Spans truss systems 5"–18" (127–457 mm) for easy overhead installation in buildings or exhibits
- Accommodates truss using up to 2" (51 mm) OD round or 1-7/8" (48 mm) square pipe
- Attaches to 1-1/2" NPT extension columns
- Cable management through column
- Weight Capacity: 250 lbs (113.3 kg)



CMA™-372 OFFSET UNISTRUT® ADAPTER

- Installs to all styles of 1-5/8" (41 mm) Unistrut®/U-Channel
- Cable management through pole and directly out of Unistrut® adapter
- Attaches to 1-1/2" NPT threaded extension column
- Ships with spring nuts and bolts for attaching to Unistrut®/U-Channel
- Weight Capacity: 500 lbs (227 kg)



CMA™-385 INTERNAL JOIST MOUNT

- Expands to bridge ceiling joists on 10"–24" (250 mm–61 cm) centers
- Adjustable clamping bracket has threaded fittings to attach to 1-1/2" NPT threaded extension columns
- Weight Capacity: 300 lbs (136.4 kg)



CMA™-390 16" (406 mm) / CMA-391 24" (61 cm) ON-CENTER CEILING PLATES

- Attaches to finished ceilings using the included lag bolts:
 - 16" (406 mm) on-center joists use the CMA-390
 - 24" (61 cm) on-center joists use the CMA-391
- Use on structural ceilings with concrete anchors (CMA-380)
- Attaches to 1-1/2" NPT extension columns
- Includes set screws
- Weight Capacity: 300 lbs (136.4 kg)



LARGE FLAT PANEL ACCESSORIES

SECURITY ACCESSORIES

PAC™-140 Q-CLAMP ACCESSORY

- Provides added stability for the PWP, PWL, PWS, PDS, PFS and PTS
- Comes as standard on other 2000 Series Q-Latch products
- Kit includes two clamps



SSC™ SECURITY SCREW COVER KITS

- Provides added protection against equipment theft
- Prohibits access to button or panhead screws by covering hardware and locking with padlock or cable
- Three kits available:
 - SSC-1 includes 3 covers for screws up to #10 (M5)
 - SSC-2 includes 3 covers for screws up to 1/4" (M6)
 - SSC-3 includes 3 covers for screws up to 5/16" (M8)
- Padlocks and cable not included



PAC™-130 Q-LATCH MOUNTING SYSTEM LOCKABLE LATCH

- Lockable latch for PSM, PAC-251, PAC-300 and PAC-301
- Includes adaptable accessory flag and hardware
- Compatible with padlocks



PAC™-135 Q-LATCH MOUNTING SYSTEM LOCKABLE LATCH WITH PADLOCK

- Lockable latch with padlock and keys for PSM, PAC-251, PAC-300 and PAC-301
- Includes adaptable accessory flag, padlock, keys and hardware
Note: Padlock and keys not shown.



EXTENSION COLUMNS

CMA™ ADJUSTABLE EXTENSION COLUMNS

- Use with any 1-1/2" NPT accessory
- Provides a range of height adjustment in 1" (25 mm) increments
- Includes set screws for added rigidity
- Weight capacity: 500 lbs (227 kg)



Model	Length	Model	Length
CMA-006009	6"-9" (152-229 mm)	CMA-0507	5'-7" (1.5-2.1 m)
CMA-009012	9"-12" (229-305 mm)	CMA-0608	6'-8" (1.8-2.4 m)
CMA-012018*	12"-18" (305-457 mm)	CMA-0709	7'-9" (2.1-2.7 m)
CMA-018024	18"-24" (45.7-61 cm)	CMA-0810	8'-10" (2.4-3.1 m)
CMA-0203	2'-3" (0.6-0.9 m)	CMA-0911	9'-11" (2.7-3.4 m)
CMA-0305	3'-5" (0.9-1.5 m)	CMA-1012**	10'-12" (3.1-3.7 m)
CMA-0406	4'-6" (1.2-1.8 m)		

*Now available in black, white or silver. To order select accessories in white or silver, simply add a "W" for white or an "S" for silver to the end of the part number.
**CMA1012 Adjustable Extension Column cannot ship by UPS due to length.

CMA™ FIXED EXTENSION COLUMNS

- Use with any 1-1/2" NPT accessory
- Includes 1-1/2" NPT column threaded on both ends, 3"-6' (76 mm-1.8 m) lengths
- Weight capacity: 500 lbs (227 kg)



Model	Length	Model	Length
CMA-003	3" (76 mm)	CMA-024	2' (0.6 m)
CMA-006*	6" (152 mm)	CMA-036	3' (0.9 m)
CMA-008	8" (203 mm)	CMA-048	4' (1.2 m)
CMA-012	12" (305 mm)	CMA-060	5' (1.5 m)
CMA-018	18" (457 mm)	CMA-072	6' (1.8 m)

*Now available in black, white or silver. To order select accessories in white or silver, simply add a "W" for white or an "S" for silver to the end of the part number.

PAC™-115 STEEL STUD/DRYWALL ANCHOR KIT

- Allows installation of large flat panel displays to metal studs or directly to drywall
- Kit includes four heavy-duty toggle anchors
- Drywall must be at least 1/2" (13 mm) thick
- Maximum Load: 175 lbs (79.4 kg)



Note: Not compatible with swing arm mounts.

LARGE FLAT PANEL ACCESSORIES

*To order select accessories in white or silver, simply add a "W" for white or an "S" for silver to the end of the part number.

CEILING PLATES

CMA™-100 8" (203 mm) CEILING PLATE WITH ATTACHED ADJUSTABLE 1-1/2" NPT COLUMN

- Universal solution for most structural ceiling installations
- Easy way to achieve the correct drop distance 24-1/4"–46" (61.6–116.8 cm)
- Adjustable in 3/4" (19 mm) increments
- Unmatched rigidity with included set screws
- Weight Capacity: 500 lbs (227 kg)
- Also available for 2" NPT column, order CMA-260
- NEW** ■ Now available in black, white or silver*



CMA™-110 8" (203 mm)/ CMA-115 6" (152 mm) CEILING PLATE WITH 1-1/2" NPT OPENING

- Combine with CMA Fixed Extension Column or CMA Adjustable Extension Column
- Includes set screw
- Weight Capacity: 500 lbs (227 kg)
- Also available for attaching to 2" NPT, order CMA-210

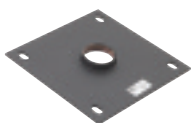

CMA™-330 OFFSET CEILING PLATE

- Routes cables through the extension column and out the top of the ceiling plate for cable management
- Includes an 8" (203 mm) square ceiling plate with a 1-3/4" (45 mm) high offset
- Overall Height: 4-1/16" (103 mm)
- Attaches to 1-1/2" NPT extension column
- Weight Capacity: 500 lbs (227 kg)
- Also available for 2" NPT, order CMA-332



CMA™-345 STRUCTURAL CEILING PLATE WITH FLEX JOINTS

- Flexible neoprene rubber joints minimize the transfer of shock and extreme vibration from the plate to the equipment
- Attaches to 1-1/2" NPT extension column



LATERAL SHIFT ACCESSORIES

PAC™-125 LATERAL SHIFT

- Compatible with the PSM, PST, PRO, PLP
- Easy mounting solution for 24" (61 cm) on-center stud systems or 4" (102 mm) of lateral shift on either side of a 16" (356 mm) on-center stud system
- Includes two 28" (71 cm) T-slotted aluminum extrusions and safety-catch screws
- Seven mounting holes at 4" (102 mm) intervals, grooved for drilling at other intervals
- Also use to mount side-by-side to create video walls
- Weight Capacity: 150 lbs (68 kg)

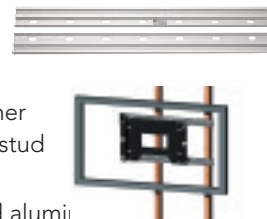

PAC™-126 LATERAL SHIFT

- Compatible with the PSM, PST, PRO, PLP
- 2" (51 mm) lateral shift on either side of a 32" (81.3 cm) on-center stud system
- Span three 16" (406 mm) on-center studs for added stability
- Includes two 36" (91.4 cm) T-slotted aluminum extrusions and safety-catch screws
- Nine mounting holes at 4" (102 mm) intervals, grooved for drilling at other intervals
- Also use to mount side-by-side to create video walls
- Weight Capacity: 150 lbs (68 kg)

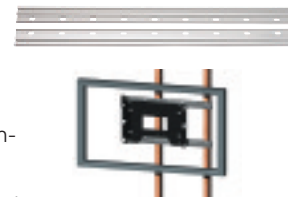

ENS™ LATERAL SHIFT EXTRUSION FOR VIDEO WALLS

- Compatible with the PSM, PST, PRO, PLP
- Aluminum extrusion in custom lengths
- Order per inch, up to 108" (274.3 cm); order multiple extrusion for added length
- Also use to mount side-by-side to create video walls
- Specify the number of displays being used when ordering
- Weight Capacity: 150 lbs (68 kg)



LARGE FLAT PANEL ACCESSORIES

INSTALLATION ADAPTERS

CMA™-160 INSTALLATION JOB BOX

- Provides one central location for electrical hook-ups, cables and equipment
- Attaches to two 1-1/2" NPT columns
- Includes outlet knockouts and space to hold wiring and electrical equipment
- Remains hidden above the ceiling
- Requires two 1-1/2" NPT Extension Columns
- Weight Capacity: 250 lbs (113.6 kg)



CMA™-152 1-1/2" TO 1-1/2" NPT COUPLER

- Manages messy cables on large flat panel displays
- Combines two 1-1/2" NPT columns for added length
- Slot in the coupler allows easy cable access
- Includes two set screws for stability and security
- Weight Capacity: 500 lbs (227 kg)



CMA™-270 THREADED PIPE COUPLER

- Attaches two 1-1/2" NPT threaded columns together for added length
- Adds 2-1/16" (52 mm) height to installation
- Two set screws included
- Weight Capacity: 500 lbs (227 kg)
- Now available in black, white or silver*



CMA™-275 QUICK-SNAP CABLE COVER

- Cable management cap
- Quickly attaches to 1-1/2" or 2" NPT extension columns
- Hides cables and creates an aesthetic look
- Unique plastic extrusion snaps on easily
- Kit includes three 4' (1.2 m) sections that can easily be cut to size



CMA™-340 SUPPORT BRACKET AND CABLE ASSEMBLY

- Use with long extension installations
- Attaches to a 1-1/2" or 2" NPT threaded extension column for added stability where rigidity or sway dampening is needed
- Includes a bracket, four cables approximately 10 ft (3 m) each, and four turnbuckles



CMA™-351 HEAVY-DUTY SWIVEL ADAPTER WITH STOPS

- Allows smooth axis rotation or the ability to set swivel 0°-330°
- Quick rotation solution
- Attaches to a 1-1/2" NPT threaded extension column
- Easy cable access
- Weight Capacity: 500 lbs (227 kg)



CMA™-640 FINISHING RING

- Aesthetic solution for ceilings
- Covers hole where extension column passes through the ceiling tile
- Ring is hinged to open



For more information about the following accessories, please visit www.chiefmfg.com.

- CMA-251 2" to 1-1/2" NPT Adapter/Reducer
- MAC-160 Medium Flat Panel Accessory Bracket
- P-45 45" (114 mm) Chrome Post
- PAC-100 Accessory Shelf (pg. 45)
- PAC-105 Extreme Stabilizer Kit
- PAC-110 Aesthetic Cover Kit
- PAC-141 Back-to-Back Display Head Assembly
- PAC-142 Single Display Head Assembly
- PAC-143 Back-to-Back Small Flat Panel Head Assembly
- PAC-150 Video Conferencing Kit (pg. 48)
- PAC-160 / PAC-165 Small Flat Panel Accessory Bracket
- PAS-1 18" x 24" (457 mm x 61 cm) Accessory Shelf (pg. 47)
- PAS-100 Smoked Acrylic Accessory Shelf (pg. 48)
- PTCLF Leveling Feet
- TPA 100/105 Finishing Covers
- TPA-110 Small Flat Panel Tilt-Adjustable Pole Mount
- TPA-111 Small Flat Panel Tilt-Adjustable Truss Mount
- TPA-112 Small Flat Panel Fixed Pole/Truss Mount
- USA-1 13" x 13" (330 x 330 mm) Accessory Shelf (pg. 47)

NEW

**Now available in black, white or silver. To order select accessories in white or silver, simply add a "W" for white or an "S" for silver to the end of the part number.*



SECTION 3 MEDIUM FLAT PANEL SOLUTIONS

medium

26-40" Screens



Chief's newest solution to flat panel mounting, the medium plasma and LCD TV mounts are designed with innovative features for superior support. Solid construction and rigorous testing ensure these mounts are safe and secure to last over time. There are a variety of mounts to choose from, featuring Chief's Q-Latch™ Mounting System – a patent-pending design that allows the installer to easily lift and set the screen on the mount and lock it into place, and Centris™ Technology for easy pivot and tilt adjustments to rotate the screen in any direction.

HOW TO CHOOSE A MEDIUM FLAT PANEL MOUNT

Choosing the right medium flat panel mount ensures the best performance. All Chief Medium Flat Panel Mounts offer industry-leading features:

- Quality, Innovative Designs – Low-profile designs are paramount for professional applications
- Advanced Security – Chief offers an exclusive Q-Latch™ Mounting System
- Superior Technology – With Chief's patented G-Force™ Gravity-Centered Tilt and Centris™ Technology
- Service Excellence for all your installation needs
- Quick Shipping – Most Chief mounts ship within 24 hours

Q-LATCH™ MOUNTING SYSTEM

Chief's Q-Latch Mounting System safely secures screens to the mount in three easy steps and is included with FUSION and REACTION Series flat panel mounts.

CENTRIS™ TECHNOLOGY

Chief's Centris Technology self-adjusts to support different display weights. This user-friendly feature enables effortless tilt, pivot and swivel at any angle.



MEDIUM FLAT PANEL



CHIEF ADDS VALUE TO EVERY MOUNT WE MAKE.

End-User Focused

■ Customer-Friendly Designs

- Ultra low-profile designs keep mounts hidden behind the screen
- Fingertip tilt adjustments for custom screen angles
- Lateral shift allows for ideal viewing positions

■ Centris Technology

Offers smooth fingertip adjustments and staying power at any angle.

■ Ultra Low-Profile Design

Ensures the mount stays hidden behind the screen.

Proven Quality

■ Industry Leader

27 years of engineering excellence.

■ Solid Steel Construction

Designed with heavy gauge steel.

■ Rigorous Testing

Every mount undergoes a series of tests to ensure a safe and secure installation.

■ Custom and Universal Solutions

Choose from an expansive standard product offering, or utilize Chief's design expertise for a custom fit.

Faster Installation

■ Rapid Level™ System

Provides hands-free leveling of mount on the wall.

■ Q-Latch™ Mounting System

Safely and easily secures the mount and locks it into place. Available with FUSION and REACTION models only.

■ Integrated Lateral Shift

Provides ultimate installation flexibility.

Superior Service

■ Expert and Accessible Customer Service

- Knowledgeable support from experienced industry professionals
- Order tracking to technical issues in one phone call

■ On-Time Delivery

Most products ship within 24 hours after receipt of purchase order.



Exclusive features like Centris™ Technology, available on all CYNERGY Mounts, allows easy fingertip adjustments.



Chief's MTR Tilt Wall Mount safely secures displays up to 100 lbs.



Chief's patented Q-Latch Mounting System allows installation in 3 easy steps.



Gunnar Berg, Chief Assembly Manager ensures products are quality-built.

MEDIUM FLAT PANEL PRODUCT OVERVIEW

FIXED WALL MOUNTS

MSR™
Fixed Wall Mount

FUSION™
FIXED AND TILT WALL MOUNTS

PG 60



NEW

MAX WEIGHT: 100 lbs **S** **B**

TILT WALL MOUNTS

MTR™
Tilt Wall Mount

FUSION™
FIXED AND TILT WALL MOUNTS

PG 61



NEW

MAX WEIGHT: 100 lbs **S** **B**

SWING ARM MOUNTS

JWP™
Pivot/Tilt Wall Mount

with Centris™ Technology
CYNERGY™
SWING ARM MOUNTS

PG 63



NEW

MAX WEIGHT: 75 lbs **S** **B**

JWS™
Single Arm Wall Mount

with Centris™ Technology
CYNERGY™
SWING ARM MOUNTS

PG 63

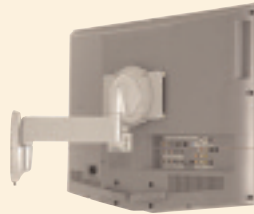

NEW

MAX WEIGHT: 75 lbs **S** **B** 12" EXTENSION

JWP™
Dual Arm Wall Mount

with Centris™ Technology
CYNERGY™
SWING ARM MOUNTS

PG 63

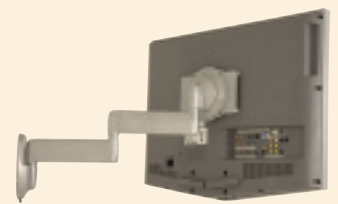

NEW

MAX WEIGHT: 75 lbs **S** **B** 20" EXTENSION

medium
26 - 40" TVs

MEDIUM FLAT PANEL PRODUCT OVERVIEW

CEILING MOUNTS

MCS™
Single Ceiling Mount

PG 64



NEW

MAX WEIGHT: 100 lbs

MCD™
Dual Ceiling Mount

PG 64



NEW

MAX WEIGHT: 200 lbs

SWING ARM MOUNTS

MWH™
Single Swing Arm Wall Mount
Single Stud

REACTION
SWING ARM MOUNTS

PG 62

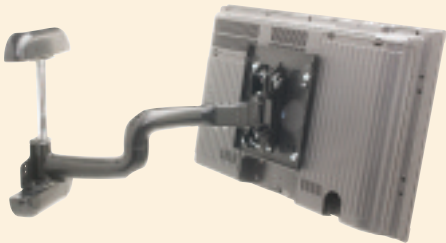

NEW

MAX WEIGHT: 100 lbs 25" EXTENSION S B

MWR™
Single Swing Arm Wall Mount
Dual Stud

REACTION
SWING ARM MOUNTS

PG 62

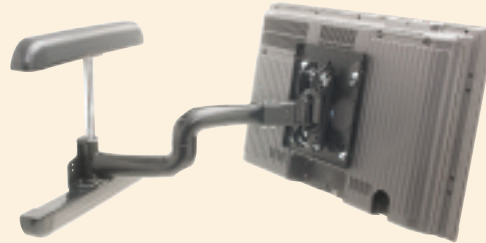

NEW

MAX WEIGHT: 125 lbs 25" EXTENSION S B

MEDIUM FLAT PANEL WALL MOUNTS – FIXED

CUSTOM OR UNIVERSAL

NEW

FUSION
FIXED AND TILT WALL MOUNTS

MSR™ FIXED WALL MOUNT

Mounting flexibility and ultra low-profile design that is ideal for digital display or retail signage.



FAQ

1. What screen size is the MSR designed for?

A The MSR is designed for 26"–40" medium flat panels up to 100 lbs.

2. Is the MSR available as a universal solution?

A Yes. Simply order the MSR-V and get a VESA universal solution that accommodates 100 x 100 mm, 200 x 100 mm, 200 x 200 mm, 400 x 200 mm, 300 x 100 mm and 300 x 200 mm patterns. See ordering steps below to order a custom solution.

HOW TO ORDER

1. Determine which style mount will best suit your needs.
2. For custom model number, look up your display in the cross-reference chart or on the website. Order MSR-xxxx, model number includes interface bracket.
3. For universal VESA® model number, order MSR-V.
4. Order MSR-210 for VESA patterns 100 x 100 mm, 200 x 100 mm, 200 x 200 mm,
5. Fax or e-mail your order to Customer Service at 877.894.6918 (domestic) or 952.894.6918 (international), or orders@chiefmfg.com.

Q-Latch™ Mounting System

- Offers quick connect/disconnect
- Secures display with a latching flag
- Includes integrated security with the addition of a padlock
- Mounts in portrait or landscape positions



Rapid Level™ System

Provides hands-free leveling of mount on wall.

Ultra Low-Profile Design

Ensures the mount stays hidden behind the screen.

Cable Management

Expanded wall plate opening provides cable access and reduces risk of outlet interference.

Solid Steel Construction

Designed with heavy gauge steel, press-in studs and lock nuts for ultimate strength.

Integrated Lateral Shift

For easy positioning of screen, up to 1-1/2" (32 mm).



Multiple Ordering Options

- Custom interface for fast install
- Universal for stocking; order MSR-V
- Wall mount without interface for pre-installation

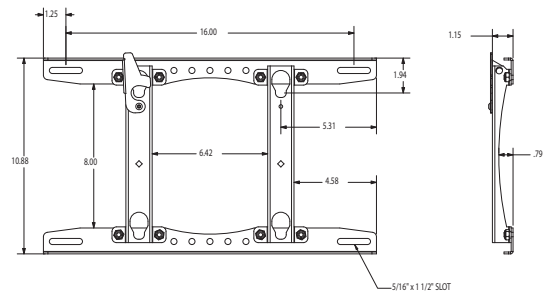

SPECIFICATIONS

Depth From Wall*	1-1/4" (32 mm)
Dimensions WxHxD	18-1/2" x 10-7/8" x 1-1/4" (470 x 276 x 32 mm)
Lateral Shift	1-1/2" (38 mm) left/right of 16" (40 cm) Centers 2" (51 mm) left/right of Single Stud
Color	Black
Weight Capacity	100 lbs (45.4 kg)

* Depth does not include interface bracket.

RECOMMENDED ACCESSORIES

PAC-115 Steel Stud/Drywall Anchor Kit	67
PAC-125 Lateral Shift Accessory	67

PAGE

MEDIUM FLAT PANEL WALL MOUNTS – TILT

CUSTOM OR UNIVERSAL

NEW

FUSION
FIXED AND TILT WALL MOUNTS

MTR™ TILT WALL MOUNT

Ultra low-profile tilt mount allows easy positioning for medium flat panel screens at any angle.



Q-Latch™ Mounting System

- Offers quick connect/disconnect
- Secures display with a latching flag
- Includes integrated security with the addition of a padlock
- Mounts in portrait or landscape positions



Cable Management

Expanded wall plate opening provides cable access and reduces risk of outlet interference.

Rapid Level™ System

Provides hands-free leveling of mount on wall.

Ultra Low Profile Design

Ensures the mount stays hidden behind the screen.

Friction-Controlled Tilt

0°–15° with lockdown capability.

Solid Steel Construction

Designed with heavy-gauge steel, press-in studs and lock nuts for ultimate strength.

Integrated Lateral Shift

For easy positioning of screen.

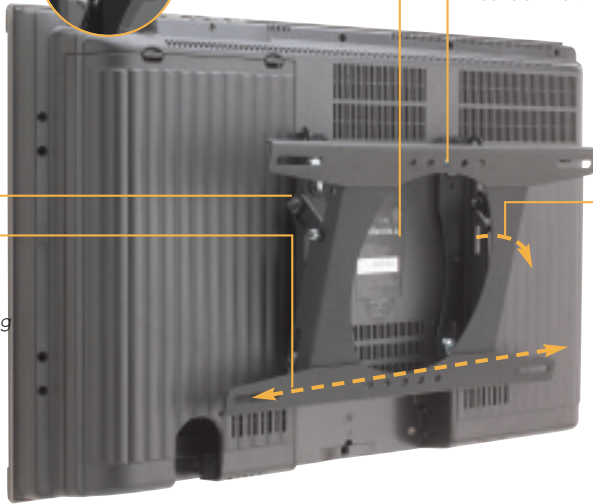

Multiple Ordering Options

- Custom interface for fast install
- Universal for stocking; order MTR-V
- Wall mount without interface for pre-installation

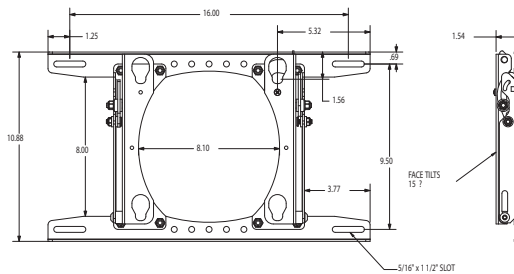

FAQ

1. What screen size is the MTR designed for?
 - A The MTR is designed for 26"–40" medium flat panels up to 100 lbs.
2. Is the MTR available as a universal solution?
 - A Yes. Simply order the MTR-V and get a VESA universal solution that accommodates 100 x 100 mm, 200 x 100 mm, 200 x 200 mm, 400 x 200 mm, 300 x 100 mm and 300 x 200 mm patterns. See ordering steps below to order a custom solution.

HOW TO ORDER

1. Determine which style mount will best suit your needs.
2. For custom model number, look up your display in the cross-reference chart or on the website. Order MTR-xxxx, model number includes interface bracket.
3. For universal VESA® model number, order MTR-V.
4. Order MTR-210 for VESA patterns 100 x 100 mm, 200 x 100 mm, 200 x 200 mm.
5. Fax or e-mail your order to Customer Service at 877.894.6918 (domestic) or 952.894.6918 (international), or orders@chiefmfg.com.

RECOMMENDED ACCESSORIES

RECOMMENDED ACCESSORIES	PAGE
PAC-115 Steel Stud/Drywall Anchor Kit	67
PAC-125 Lateral Shift Accessory	67

SPECIFICATIONS

Depth from Wall*	1-1/2" (38 mm)
Dimensions WxHxD	18-1/2" x 10-7/8" x 1-1/2" (450 x 267 x 38 mm)
Tilt	0°–15°
Lateral Shift	1-1/2" (38 mm) Left/Right of 16" (40 cm) Centers 4" (10 cm) Single Stud
Color	Black
Weight Capacity	100 lbs (45.4 kg)

* Depth does not include interface bracket.

MEDIUM FLAT PANEL SWING ARM MOUNTS

CUSTOM OR UNIVERSAL

NEW

REACTION
SWING ARM MOUNTS

MWR™/MWH™ SINGLE SWING ARM WALL MOUNT

Provides the ultimate flexibility and strength for medium flat panel displays. Great for digital signage to home use.

HE  25" EXTENSION

FAQ

1. What is the difference between the MWR and MWH?

A The MWR provides 16" center stud mounting. The MWH is single stud mounting only.

2. Are the MWR and MWH available as universal solutions?

A Yes. Simply order the MWR-V or MWH-V and get a VESA® universal solution that accommodates 100 x 100 mm, 200 x 100 mm, 200 x 200 mm, 400 x 200 mm, 300 x 100 mm and 300 x 200 mm patterns. See ordering steps below to order a custom solution.

HOW TO ORDER

1. Determine which style mount will best suit your needs.
2. For custom model number, look up your display in the cross-reference chart or on the website. Order MWR-xxxx or MWH-xxxx, model number includes interface bracket.
3. For universal VESA® model number, order MWR-V or MWH-V.
4. Order MWR-210 or MWH-210 for VESA patterns 100 x 100 mm, 200 x 100 mm, 200 x 200 mm.
5. Fax or e-mail your order to Customer Service at 877.894.6918 (domestic) or 952.894.6918 (international), or orders@chiefmfg.com.

- **Mounting Guide System**
Simple, one-man installation by hanging mount on two lag bolts.
- **Ultimate Flexibility**
Extreme range of motion for every viewing angle.

- **Q-Latch™ Mounting System**
 - Offers quick connect/disconnect
 - Secures display with a latching flag
 - Includes integrated security with the addition of a padlock

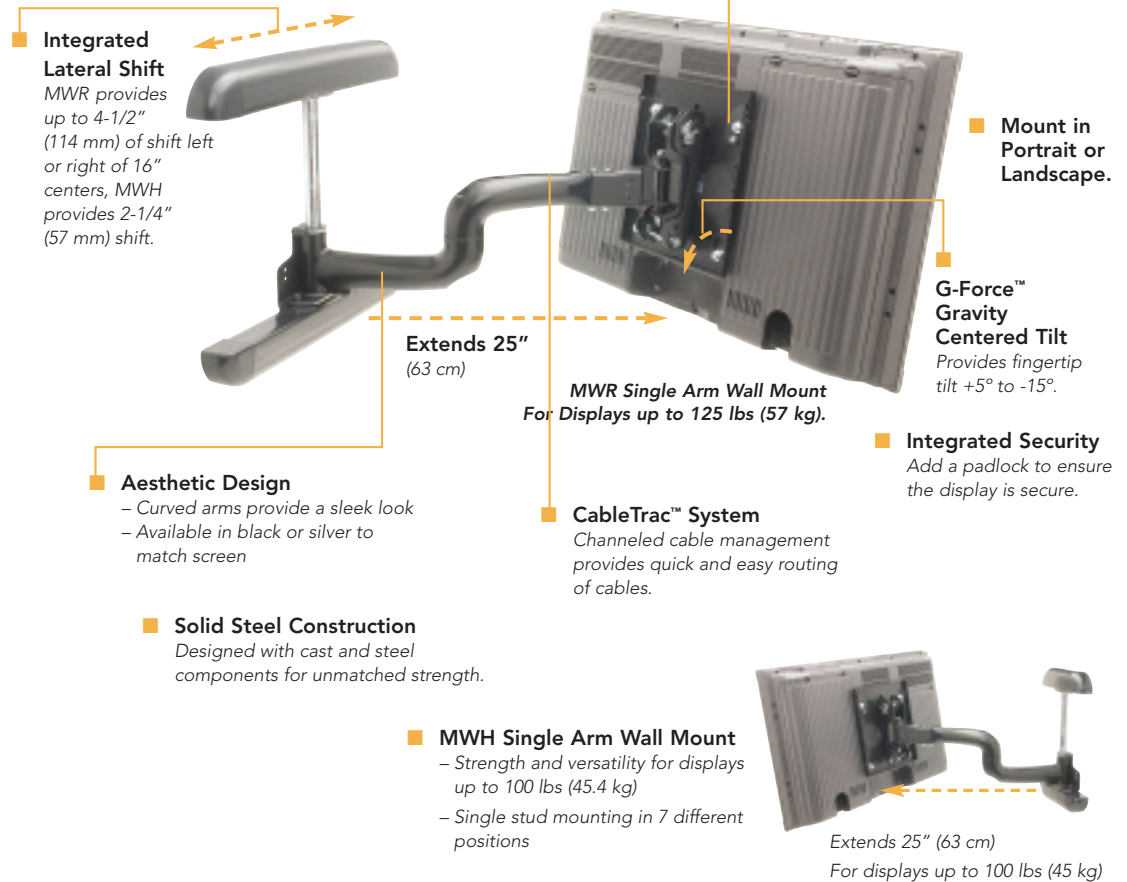

SPECIFICATIONS

	MWR	MWH
Depth From Wall	3-3/8" (86 mm)	3-3/8" (86 mm)
Extension From Wall	24-7/8" (63.2 cm)	24-7/8" (63.2 cm)
Dimensions WxHxD	23-5/8" x 18" x 3-3/8" (60 x 45.7 x 8.6 cm)	23-5/8" x 18" x 3-3/8" (60 x 45.7 x 8.6 cm)
Lateral Shift	4-1/2" (114 mm)	2-1/4" (57 mm)
Color	Silver or Black	Silver or Black
Weight Capacity	125 lbs (56.7 kg),	100 lbs (45.4 kg)

RECOMMENDED ACCESSORIES

NA

PAGE

MEDIUM FLAT PANEL SWING ARM MOUNTS

CUSTOM OR UNIVERSAL

NEW



JWP™ / JWS™ / JWD™ PIVOT/TILT WALL MOUNTS

A broad range of motion and maximum flexibility for viewing mid-size displays from multiple angles.

HE

Exclusive Centris™ Technology

- Self-adjusts to support different display weights
- Enables effortless tilt and pivot
- Fingertip tilt and swivel for viewing at any angle

Collapses to less than 3" (76 cm)

JWS and JWD only.

Solid Steel Construction

Designed with cast components for ultimate strength.

Multiple Ordering Options

- Standard mounts have VESA® 100 x 100 mm, 200 x 100 mm and 200 x 200 mm interface
- MSB custom interface available for non-VESA® screens
- Available in black or silver

For Displays up to 75 lbs (34 kg)

Maximum range of motion – from low profile to full extension.

Ultimate Flexibility

Maximum range of motion – from low profile to full extension.

Advanced Display Mounting

Teardrop hole pattern makes mounting the screen quick and easy.

Easy, 3-Step Installation

1. Attach plate to wall
2. Hang mount onto wall
3. Attach screen to mount

Clean Installation

Hidden wall mount hardware and cable concealment for a clean installation.

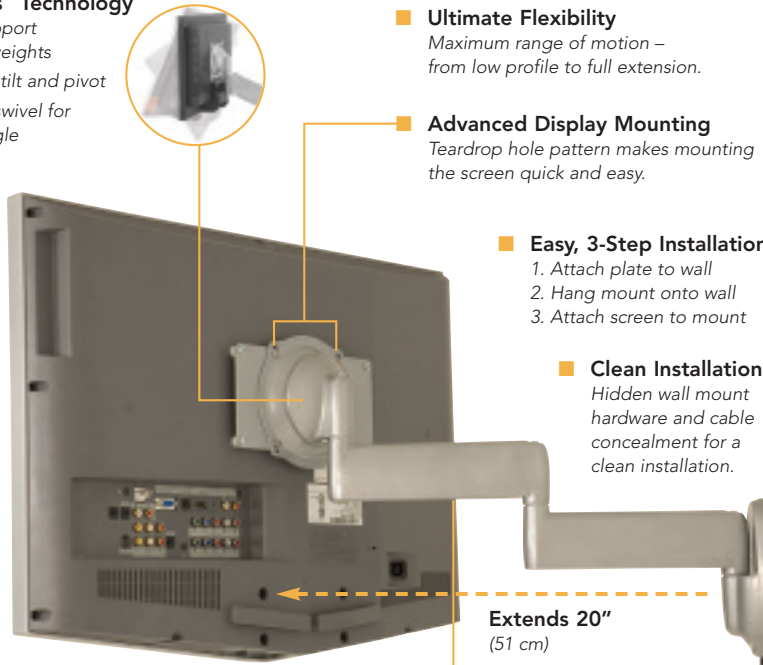

JWD Dual Arm Wall Mount

Extends 20" (51 cm)

Built-In Cable Management

- Predefined pathway for routing cables inside arms
- Conceals and protects cables

JWP Pivot/Tilt Wall Mount



JWS Single Arm Wall Mount

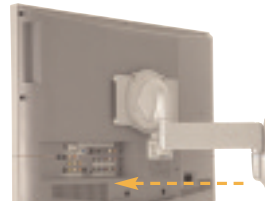

Extends 12" (304 cm)

FAQ

1. What screen size are the JWP, JWS and JWD designed for?
 - A The mounts are designed for 26"–40" medium flat panel displays up to 75 lbs (34 kg).
2. Are the JWP, JWS and JWD available as universal solutions?
 - A Yes. Simply order the JWP-210, JWS-210 or JWD-210 and get a VESA® universal solution that accommodates 100 x 100 mm, 200 x 100 mm and 200 x 200 mm patterns. See ordering steps below to order a custom solution.

HOW TO ORDER

1. Determine which style mount will best suit your needs.
2. For custom model number, look up your display in the cross-reference chart or on the website. Model number includes interface bracket.
3. For universal VESA® model number, order suffix-V (example: JWP-V).
4. Order suffix-210 for VESA patterns 100 x 100 mm, 200 x 100 mm, 200 x 200 mm.
5. Fax or e-mail your order to Customer Service at 877.894.6918 (domestic) or 952.894.6918 (international), or orders@chiefmfg.com.

RECOMMENDED ACCESSORIES

PAGE

NA

SPECIFICATIONS

	JWP	JWS	JWD
Depth from Wall	3-5/16" (85 mm)	2-11/16" (68 mm)	2-11/16" (68 mm)
Max. Extension	–	11-7/8" (301 mm)	20-3/8" (51.8 cm)
Dimensions WxHxD	6" x 8-5/16" x 3-5/16" (152 x 511 x 85 mm)	13-1/8" x 11-1/2" x 2-11/16" (333 x 292 x 68 mm)	12-1/8" x 14-11/16" x 2-11/16" (308 x 373 x 68 mm)
Tilt	+/-15°	+/-15°	+/-15°
Pivot	varies	180°	180°
Color	Silver or Black	Silver or Black	Silver or Black
Weight Capacity	75 lbs (34 kg)	75 lbs (34 kg)	75 lbs (34 kg)



MEDIUM FLAT PANEL CEILING MOUNTS

CUSTOM OR UNIVERSAL

NEW

MCS™/MCD™ SINGLE & DUAL CEILING MOUNTS

The ultimate installer-friendly ceiling mount for medium flat panel screens. Ideal for digital signage applications.

FAQ

1. Does the MCS come with an extension column and ceiling plate?

A No. Each installation has different structural adapter requirements and drop lengths so Chief provides accessories separately.

2. What screen size are the MCS and MCD designed for?

A The MCS and MCD are designed for 26 – 40" flat panels up to 100 lbs (45.4 kg).

3. Are the MCS and MCD available as universal or custom solutions?

A Yes. Simply order the MCS-V or MCD-V and get a VESA universal solution that encompasses 100 x 100, 200 x 100, 200 x 200, 400 x 200, 300 x 100 and 300 x 200 mm patterns. See ordering steps below to order a custom solution.

HOW TO ORDER

1. Determine which style mount will best suit your needs.
2. For custom model number, look up your display in the cross-reference chart or on the website. Order MCS-xxxx or MCD-xxxx, model number includes interface bracket.
3. For universal VESA® model number, order MCS-V or MCD-V.
4. Fax or e-mail your order to Customer Service at 877.894.6918 (domestic) or 952.894.6918 (international), or orders@chiefmfg.com.

■ Solid Steel Construction

Designed with steel components for unmatched strength.

■ Q-Latch™ Mounting System

- Offers quick connect/disconnect
- Secures display with a latching flag
- Includes integrated security with the addition of a padlock



■ Cable Management

Easily route cables through 1-1/2" NPT extension column.

Shown with optional CMA-018 and CMA-101 Accessories (sold separately).

■ G-Force™ Gravity-Centered Tilt

Provides fingertip tilt +5° to -20°, can be tightened for public applications.

■ Ultimate Flexibility

Portrait and landscape mounting capability.

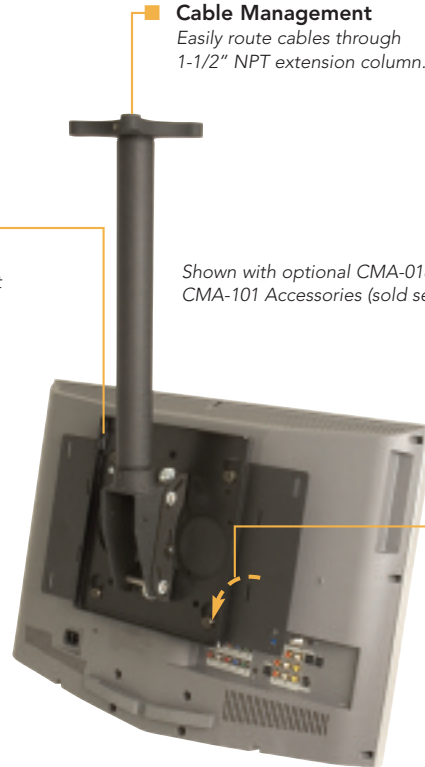

MCS Single Ceiling Mount



■ MCD Dual Ceiling Mount

Supports two displays back-to-back, up to 200 lbs.

SPECIFICATIONS

	MCS	MCD
Height Adjustment		
Dimensions WxHxD	Varies	Varies
Tilt	+5°, -20°	+5°, -20°
Roll	5°	5°
Yaw	360°	360°
Color	Black	Black
Weight Capacity	100 lbs (45.4 kg) ,	200 lbs (45.4 kg)

RECOMMENDED ACCESSORIES

PAGE

CMA-100 8" Ceiling Plate with Attached Adjustable 1-1/2" NPT	66
CMA-101 5" Designer Ceiling Plate	66
CMA-152 1-1/2" to 1-1/2" NPT Coupler	67
CMA-165 Internal Joist Ceiling Kit	66
CMA-390 16" On Center Ceiling Plate	67
Extension Columns	66

*Confirm that the combined weight of the screen and accessory will not exceed the mount's rated capacity.

MEDIUM FLAT PANEL ACCESSORIES

CEILING PLATES

CMA™-101 5" (127 mm) DESIGNER CEILING PLATE WITH 1-1/2" NPT OPENING

- Cost effective, attractive solution for simple installs
- Can hold equipment using all four holes or two opposing holes
- 4" x 4" (102 x 102 mm) mounting pattern is designed to allow use of 3/8" (10 mm) mounting bolts
- Includes set screw to secure a 1-1/2" NPT to the ceiling plate
- Weight Capacity: 500 lbs (227 kg)



CMA™-105 4" (102 mm) CEILING PLATE WITH 1-1/2" NPT OPENING

- Combines with fixed or adjustable CMA extension columns to customize your installation
- Great for installations where a short extension column is used, or when there isn't space for a larger plate
- Includes set screw
- Weight Capacity: 500 lbs (227 kg)



CMA™-110 8" (203 mm)/ CMA-115 6" (152 mm) CEILING PLATE WITH 1-1/2" NPT OPENING

- Combine with CMA Fixed Extension Column or CMA Adjustable Extension Column
- Includes set screw
- Weight Capacity: 500 lbs (227 kg)
- Also available for attaching to 2" NPT, order CMA-210

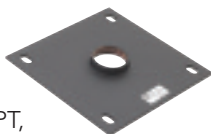

CMA™-165 INTERNAL JOIST CEILING KIT

- Suspends projector between ceiling joists
- Similar to a ceiling fan installation
- Installs with just a 4" (102 mm) hole in the ceiling
- Cable management system for a clean installation
- Attaches to 1-1/2" NPT extension column
- Weight Capacity: 50 lbs (22.7 kg)



EXTENSION COLUMNS

CMA™-100 8" (203 mm) CEILING PLATE WITH ATTACHED ADJUSTABLE 1-1/2" NPT COLUMN

- Universal solution for most structural ceiling installations
- Easy way to achieve the correct drop distance 24-1/4"–46" (61.6–116.8 cm)
- Adjustable in 3/4" (19 mm) increments
- Unmatched rigidity with included set screws
- Weight Capacity: 500 lbs (227 kg)
- Also available with 2" NPT column, order CMA-260
- Now available in black, white or silver **NEW**

CMA™ FIXED EXTENSION COLUMNS

- Use with any 1-1/2" NPT accessory to lower the projector to desired height
- Includes 1-1/2" NPT column threaded on both ends, 3'–6' (0.9–1.8 m) lengths
- Weight Capacity: 500 lbs (227 kg)

Model	Length	Model	Length
CMA-003	3" (76 mm)	CMA-024	2' (0.6 m)
CMA-006*	6" (152 mm)	CMA-036	3' (0.9 m)
CMA-008	8" (203 mm)	CMA-048	4' (1.2 m)
CMA-012	12" (305 mm)	CMA-060	5' (1.5 m)
CMA-018	18" (457 mm)	CMA-072	6' (1.8 m)

* Now available in black, white or silver. To order select accessories in white or silver, simply add a "W" for white or an "S" for silver to the end of the part number.

INSTALLATION ADAPTERS

CMA™-152 1-1/2" TO 1-1/2" NPT COUPLER

- Manages messy cables
- Combines two 1-1/2" NPT columns for added length
- Slot allows easy cable access
- Includes two set screws for stability and security
- Weight Capacity: 500 lbs (227 kg)



CMA™-351 HEAVY-DUTY SWIVEL ADAPTER WITH STOPS

- Allows smooth axis rotation or the ability to set swivel 0°–330°
- Quick rotation solution for projecting on more than one wall
- Attaches to a 1-1/2" NPT threaded extension column
- Weight Capacity: 500 lbs (227 kg)



PAC™-115 STEEL STUD/DRYWALL ANCHOR KIT

- Allows installation of large flat panel displays to metal studs or directly to drywall
- Kit includes four heavy-duty toggle anchors
- Drywall must be at least 1/2" (13 mm) thick
- Maximum load: 175 lbs (79.4 kg)



Note: Not compatible with swing-arm mounts.

CMA™-390 16" (406 mm) ON-CENTER CEILING PLATE

- Attaches to finished ceilings using the included lag bolts
- Attaches to 1-1/2" NPT extension columns
- Includes set screws
- Weight Capacity: 300 lbs (136.4 kg)



LATERAL SHIFT

PAC™-125 LATERAL SHIFT

- Compatible with the PSM, PST, PRO, and PLP
- Easy mounting solution for 24" (61 cm) on-center stud systems or 4" (102 mm) of lateral shift on either side of a 16" (356 mm) on-center stud system
- Includes two 28" (71 cm) T-slotted aluminum extrusions and safety-catch screws
- Seven mounting holes at 4" (102 mm) intervals, grooved for drilling at other intervals
- Also use to mount side-by-side to create video walls
- Weight Capacity: 150 lbs (68 kg)



CMA™-700 EASY INSTALLATION KIT

- Provides all the accessories you need for a complete structural ceiling installation
- Easy to install
- Includes a 6" x 6" (152 x 152 mm) ceiling plate and adjustable extension column that extends 12"–18" (305 – 457 mm)
- Weight Capacity: 500 lbs (227 kg)
- Now available in black, white or silver* **NEW**



* To order select accessories in white or silver, simply add a "W" for white or an "S" for silver to the end of the part number.



SECTION 4 SMALL FLAT PANEL SOLUTIONS

small
10-26" Screens



Versatility and an award-winning design allow Chief's Small Flat Panel Mounts to adapt to every situation. These mounting solutions are easy to install with only three steps, and even easier to use with effortless adjustments. With the exclusive Q2™ and Centris™ technologies, you can find a mount to tilt, swing, pan or rotate your screen in any direction. Whether tucked in a corner, or pulled out and angled, Chief's wall, desk, ceiling, pole and swing-arm mounts create endless possibilities.

HOW TO CHOOSE A SMALL FLAT PANEL MOUNT

Choosing the correct mount for your application can be tricky. Whether your application demands full articulation or a simple static solution, a mount that performs well and is easy to install is essential. Chief offers a full line of solutions that are ideal for a wide range of applications, from under your kitchen cabinet to commercial signage.

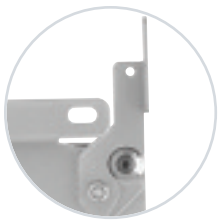

Q2™ MOUNTING SYSTEM

Quick, easy and versatile, Chief's exclusive Q2™ Mounting System is designed to make small flat panel mounts user-friendly. Q2 uses self-aligning mating components, a steel latching flag and an optional security accessory to help you easily guide, latch and lock your display to the mount. The universal mounting pattern allows you to install the display in either portrait or landscape position, quickly and easily change out displays or move a display between mounts.



CENTRIS™ SYSTEM

Chief's Centris™ System is designed to enhance the appearance and functionality of your small flat panel display. All Centris mounts incorporate a smooth tilt function, adjustable pivots, easy display attachment and a hidden wall plate. Mounts with the Centris System will not sag or drift over time with the weight of the display and can support up to 40 lbs (18.2 kg).

SMALL FLAT PANEL



CHIEF ADDS VALUE TO EVERY MOUNT WE MAKE.

End-User Focused

■ Centris Technology

- Self-adjusts to support different display weights
- Enables effortless tilt and pivot
- Fingertip tilt and swivel for viewing at any angle

■ Complete Solution

Compatible with multiple accessories to customize any installation.

■ Independently Adjustable at Pivot Points (Height-Adjustable Models)

Provides customized control and can be optimized for touchscreens.

Proven Quality

■ Industry Leader

27 years of engineering excellence.

■ Solid Steel Construction

Designed with heavy-gauge steel.

■ Rigorous Testing

Every mount undergoes a series of tests to ensure a safe and secure installation.

■ Custom and Universal Solutions

Choose from an expansive standard product offering, or utilize Chief's design expertise for a custom fit.

Faster Installation

■ Easy, 3-Step Installation (Centris Mounts)

Attach plate to wall, hang the mount, attach the display.

■ Total Solution (Q2 Mounts)

Includes all mounting hardware.

■ Mounting Flexibility

Install displays in portrait or landscape positions.

Superior Service

■ Expert and Accessible Customer Service

- Knowledgeable support from experienced industry professionals
- Order tracking to technical issues in one phone call

■ On-Time Delivery

Most products ship within 24 hours after receipt of purchase order.



Chief's exclusive Centris Technology allows easy fingertip tilt and swivel.



Every Chief mount undergoes a series of tests to ensure a safe and secure installation.



Q2 helps guide, latch and lock the display to the mount.



Yvette Danz, Chief Customer Service helps to make a difficult installation easy.

SMALL FLAT PANEL PRODUCT OVERVIEW

small
10 – 26" TVs

WALL MOUNTS

FSM™
Fixed Wall Mount

PG 72



MAX WEIGHT: 45 lbs **S**

FPM™
Tilt Wall Mount

PG 72

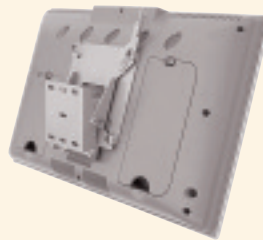

MAX WEIGHT: 45 lbs **S**

FWD
Pivot/Tilt
Wall Mount



PG 74



MAX WEIGHT: 40 lbs **B S**

FWP™
Single Arm
Wall Mount

PG 74

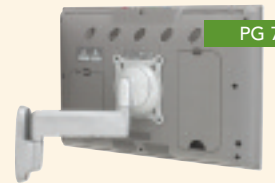

MAX WEIGHT: 40 lbs **10" EXTENSION B S**

FWS™
Dual Arm
Wall Mount

PG 74

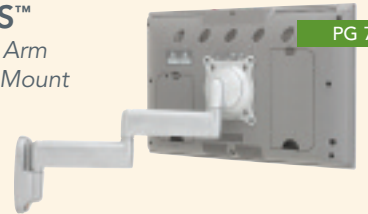

MAX WEIGHT: 40 lbs **16" EXTENSION B S**

POLE MOUNTS

FSP™
Single Display
Pole Mount

PG 73



MAX WEIGHT: 45 lbs **B S**

FDP™
Dual Display
Pole Mount

PG 73



MAX WEIGHT: 90 lbs **B S**

FPP™
Pivot/Tilt
Pole Mount

PG 78



MAX WEIGHT: 40 lbs **B S**

FPS™
Single Arm
Pole Mount

PG 78

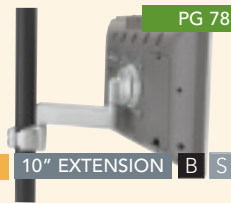

MAX WEIGHT: 40 lbs **10" EXTENSION B S**

FPD™
Dual Arm Pivot/
Tilt Pole Mount

PG 78

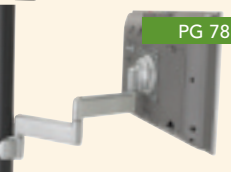

MAX WEIGHT: 40 lbs **16" EXTENSION B S**

SMALL FLAT PANEL PRODUCT OVERVIEW

DESK MOUNTS

FWV™

Single Arm Wall Mount,
Height Adjustable

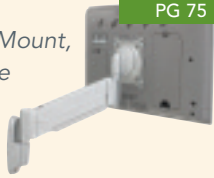

PG 75

MAX WEIGHT: 25 lbs | 13" EXTENSION | B S

FWG™

Dual Arm Wall Mount,
Height Adjustable

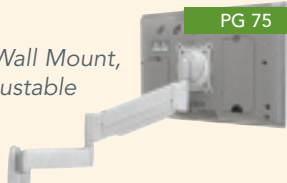

PG 75

MAX WEIGHT: 25 lbs | 20" EXTENSION | B S

FWB

Triple Arm Wall Mount,
Height Adjustable



PG 75

MAX WEIGHT: 25 lbs | 26" EXTENSION | B S

FCS™

Single Arm Desk Mount



PG 76

MAX WEIGHT: 40 lbs | 10" EXTENSION | B S

FCD™

Dual Arm Desk Mount



PG 76

MAX WEIGHT: 40 lbs | 16" EXTENSION | B S

FCV™

Single Swing Arm
Wall Mount



PG 77

MAX WEIGHT: 25 lbs | 13" EXTENSION | B S

FCG™

Dual Swing Arm
Wall Mount

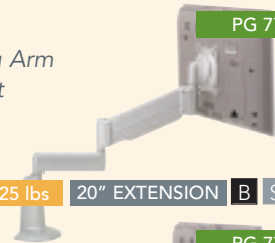

PG 77

MAX WEIGHT: 25 lbs | 20" EXTENSION | B S

FCB™

Triple Swing Arm
Wall Mount



PG 77

MAX WEIGHT: 25 lbs | 26" EXTENSION | B S

CEILING MOUNTS

FHP™

Ceiling Mount
with Adjustable
Column



PG 79

MAX WEIGHT: 40 lbs | B S

ARRAYS

FMA™-220

Dual Array

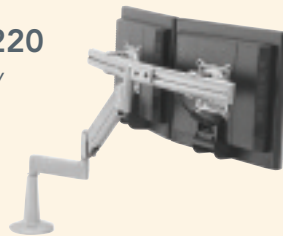

PG 80

MAX WEIGHT: 33 lbs, Fixed Arm | B S

MAX WEIGHT: 18 lbs, Height Adjustable

FMA™-320

Triple Array



PG 80

MAX WEIGHT: 30 lbs, Fixed Arm | B S



SMALL FLAT PANEL Q2 TECHNOLOGY – WALL MOUNTS

CUSTOM OR UNIVERSAL

FAQ

1. What if my display is not listed in the cross-reference chart?

A Chief's Q2 Mounts fit VESA® compliant displays. If the mounting hole pattern on the back of your display matches the VESA dimensions, order the 4100 series model of the mount you want. If your hole pattern does not match the VESA standard, call Customer Service to determine if Chief has a mount to fit your display.

2. What if my display weighs 45 lbs (20.5 kg) or more?

A Chief offers mounts for medium and large flat panel displays that are heavier than 45 lbs (20.5 kg).

HOW TO ORDER

1. Determine which style mount best meets your needs. Be sure to check screen weight.
2. For the correct model number, look up your display in the cross-reference chart or on the website. Model number includes interface bracket, non-VESA® compliant interface brackets available.
3. For the most recent cross-reference chart, visit www.chiefmfg.com or call Customer Service at 1.800.582.6480 (domestic) or 952.894.6280 (international).
4. Decide which accessories you need.

FSM™/FPM™ FIXED AND TILT WALL MOUNTS

Holds small flat panel displays close to the wall for an exceptionally slim appearance at a low price.



Includes all mounting hardware!

Quick Installation!

Two mounting methods

- Single wall stud
- Dry wall

Built-in Vertical and Lateral Shift

Up to 1" (25 mm).



FSM Fixed Wall Mount

Exclusive Q2™ Mounting System

This security accessory helps guide, latch and lock the display to the mount.

- Easily move displays between mounts
- Steel latching flag locks mount securely into place
- Can be installed in portrait or landscape positions

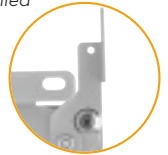

Display installs in portrait and landscape positions.

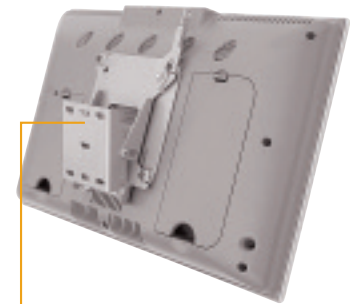
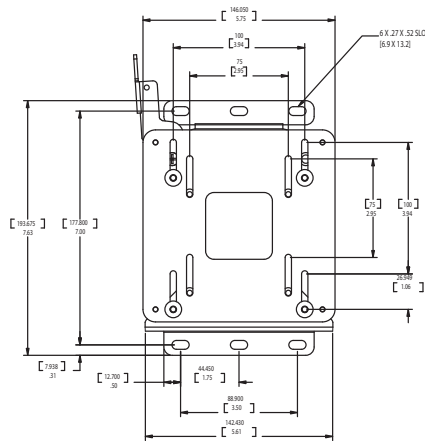

FPM Tilt Wall Mount

Rigid tilt adjustment. Loosen screws to adjust and re-tighten to secure.

SPECIFICATIONS

	FSM	FPM
Depth From Wall	7/8" (23 mm)	1-1/2" (38 mm)
Dimensions WxHxD	5-5/8" x 7-5/8" x 7/8" (143 x 194 x 23 mm)	5-5/8" x 6-7/8" x 1-1/2" (143 x 175 x 38 mm)
Lateral Shift	1" (25 mm)	1" (25 mm)
Tilt	NA	+5/-18°
Color	Silver	Silver
Weight Capacity	45 lbs (20.5 kg) stud, 30 lbs (13.6 kg) drywall	45 lbs (20.5 kg) stud, 30 lbs (13.6 kg) drywall

RECOMMENDED ACCESSORIES

FSA-1000 Security Latch System

PAGE

83

SMALL FLAT PANEL Q2 TECHNOLOGY – POLE MOUNTS

CUSTOM OR UNIVERSAL

FSP™/FDP™ SINGLE AND DUAL DISPLAY POLE MOUNTS

An innovative alternative to wall mounting that is ideal for digital display or retail signage.



Advanced Pitch Adjustment

- Set tilt at +10°, -25° with 360° rotation
- Set for touchscreen use
- Loosen to adjust and tighten to secure

Quick installation.



FDP Dual Display Pole Mount

Easy tilt adjustment, loosen screws to adjust and re-tighten to secure.



FSP Single Display Pole Mount

Ultra low-profile, sturdy steel construction.

Mounting Flexibility

- Pole can be vertical or horizontal
- Installs in portrait or landscape positions

Universal Clamp

Attaches to any 1-1/2"–2" OD pole including 1-1/2" NPT. (Clamp included)

Exclusive Q2™ Mounting System

This optimal security accessory helps guide, latch and lock the display to the mount.

- Easily move displays between mounts
- Steel latching flag locks mount securely into place
- Can be installed in portrait or landscape positions



FAQ

1. **What if my display is not listed in the cross-reference chart?**
A Chief's Q2 Mounts fit VESA® compliant displays. If the mounting hole pattern on the back of your display matches the VESA dimensions, order the 4100 series model of the mount you want. If your hole pattern does not match the VESA standard, call Customer Service to determine if Chief has a mount to fit your display.
2. **What if my display weighs 45 lbs (20.5 kg) or more?**
A Chief offers mounts for medium and large flat panel displays that are heavier than 45 lbs (20.5 kg).

HOW TO ORDER

1. Determine which style mount will best suit your needs.
2. For the correct model number, look up your display in the cross-reference chart or on the website. Model number includes interface bracket and pole clamp, non-VESA® compliant interface brackets available.
3. For the most recent cross-reference chart, visit www.chiefmfg.com or call Customer Service at 1.800.582.6480 (domestic) or 952.894.6280 (international).
4. Decide which accessories you need.

RECOMMENDED ACCESSORIES

PAGE

CMA Adjustable & Fixed Extension Columns	82
CMA-101 5" (127 mm) Ceiling Plate with 1-1/2" NPT Opening	82
CMA-110 8" (203 mm) Ceiling Plate with 1-1/2" NPT Opening	82
CMA-115 6" (152 mm) Ceiling Plate with 1-1/2" NPT Opening	82
CMA-330 Offset Ceiling Plate	82
CMA-440 Lightweight Suspended Ceiling Kit	83
CMA-450 Suspended Ceiling Kit	83
CMA-455 Suspended Ceiling Replacement Kit	83
FSA-1000 Security Latch System	83

SPECIFICATIONS

	FSP	FDP
Depth	1-7/8" (48 mm)	1-7/8" (48 mm)
Dimensions WxHxD	5-5/8" x 6-7/8" x 3-3/4" (143 x 175 x 95 mm)	5-5/8" x 6-7/8" x 3-3/4" (143 x 175 x 95 mm)
Tilt/Yaw	+10, -25° / 360°	+10, -25° / 360°
Color	Silver or Black	Silver or Black
Weight Capacity	45 lbs (20.5 kg)	45 lbs (20.5 kg) per display

SMALL FLAT PANEL CENTRIS TECHNOLOGY – WALL MOUNTS

CUSTOM OR UNIVERSAL



FWP™ -110/FWS™ -110/FWD™ -110 PIVOT/TILT WALL MOUNTS

Low-profile mount with smooth pivot and tilt adjustment for viewing flexibility.



FAQ

1. What if my display is not listed in the cross-reference chart?

A Chief's mounts fit VESA® compliant displays with a 75 x 75 mm or 100 x 100 mm hole pattern. If your hole pattern does not match the VESA standard, call Customer Service to determine if Chief has a mount to fit your display.

HOW TO ORDER

1. Verify that your display is VESA® (75 x 75 mm or 100 x 100 mm) compliant. If your display does not match either of these hole patterns or to confirm compatibility, call Customer Service at 1.800.582.6480 (domestic) or 952.894.6280 (international).
2. Determine which mount fits your application needs and order the appropriate part number. If the mounts shown do not address your installation needs, call Customer Service about other possible combinations.
3. Verify that your display meets the specified weight capacity of the mount.
4. Determine color. Please specify S for silver or B for black after the model number. For example: If ordering a FWP-110 in silver, the part number would read FWP110S.
5. Decide which accessories you will need for your installation.

Note: Interface brackets available for non-VESA® compliant displays.

■ Exclusive Centris™ Technology

- Self-adjusts to support different display weights
- Enables effortless tilt and pivot
- Fingertip tilt and swivel for viewing at any angle

■ Ultimate Flexibility

Maximum range of motion – from low profile to full extension.

■ Advanced Display Mounting

Teardrop hole pattern makes mounting the screen quick and easy.

■ Collapses to 2"

The lowest profile in the industry!

■ Easy, 3-Step Installation

1. Attach plate to wall
2. Hang mount onto wall
3. Attach display to mount

■ Multiple Ordering Options

- Standard mounts have VESA® 75 x 75 mm, 100 x 100 mm interface
- Universal VESA® interface available
- Available in black or silver

■ Built-In Cable Management

- Predefined pathway for routing cables inside arms
- Conceals and protects cables

■ Clean Installation

Hidden wall mount hardware and cable concealment for a clean installation.

■ Solid Steel Construction

Designed with cast components for ultimate strength.

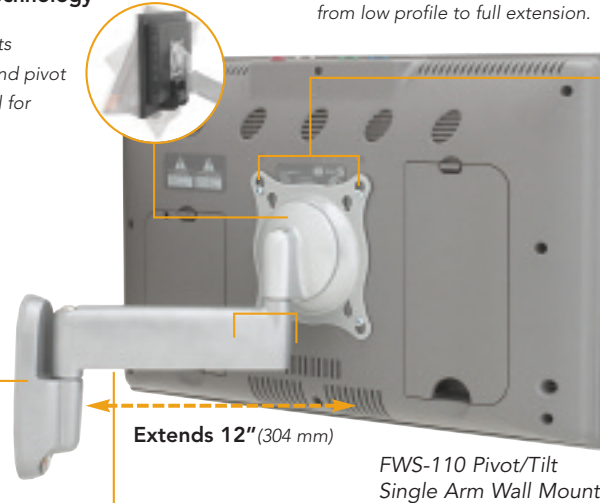

■ **FWP-110 Pivot/Tilt Wall Mount**
Smooth pivot and tilt adjustment for different viewing angles.

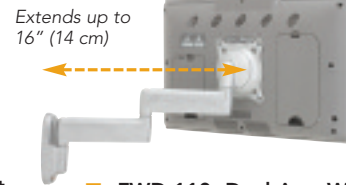

■ **FWD-110 Dual Arm Wall Mount**
Provides broad range of motion from multiple angles.

SPECIFICATIONS

	FWP	FWS	FWD
Depth from Wall	2-15/16" (74 mm)	2-1/6" (55 mm)	2-1/6" (55 mm)
Max. Extension	–	9-7/16" (240 mm)	15-15/16" (405 mm)
Dimensions WxHxD	4-3/4" x 7-1/4" x 2-5/16" (121 x 184 x 74 mm)	10" x 9-3/4" x 2-1/6" (254 x 248 x 55 mm)	8-3/16" x 12-3/16" x 2-1/6" (208 x 310 x 55 mm)
Tilt	+/-15°	+/-15°	+/-15°
Pivot	180°	180°	180°
Color	Silver or Black	Silver or Black	Silver or Black
Weight Capacity	40 lbs (18.2 kg)	40 lbs (18.2 kg)	40 lbs (18.2 kg)

RECOMMENDED ACCESSORIES

PAGE

FSA-1002 Desk Mount Adapter	83
FSA-1003* Extension Arm	83
FSA-1004* Extension Height-Adjustable Arm	83
FSA-1005 Security Accessory	83
FSA-1006 Extreme Pitch Accessory	83
FSA-1007 Centris Quick Release Interface	83

* A maximum of three arms can be used.

SMALL FLAT PANEL CENTRIS TECHNOLOGY – WALL MOUNTS

CUSTOM OR UNIVERSAL

FWV™-110/FWG™-110/FWB™-110 HEIGHT-ADJUSTABLE WALL MOUNT

A perfect solution for easy height adjustment of the screen. Ideal for the home or office.

HE

■ Exclusive Centris™ Technology

- Self-adjusts to support different display weights
- Enables effortless tilt and pivot
- Fingertip tilt and swivel for viewing at any angle



■ Independently Adjustable Tension at Pivot Points

Provides customized control and can be optimized for touchscreens.

■ Pivots 180° at Wall Plate

For a clean installation.

Extends 13" (330 mm)

■ Easy installation!

Ships fully assembled. Tension can be optimized for touchscreens.

■ Sleek, attractive design

Hides all hardware.

Extends up to 19-1/2" (495 mm)

Extends up to 26" (66 cm)

■ FWG-110 Height Adjustable Dual Arm Wall Mount

Dual arm allows for increased extension up to 19-1/2" (495 mm).

■ FWB-110 Height Adjustable Triple Arm Wall Mount

Triple arm allows for maximum extension, up to 26" (66 cm).

■ Portrait and landscape rotation and side-to-side pivot.



FWV-110
Single Arm Wall Mount

■ VESA® Compliant

■ Height Adjustment

Provides viewing at multiple angles with 13-1/4" (337 mm) maximum height adjustment.

FAQ

1. What if my display is not listed in the cross-reference chart?

■ Chief's mounts fit VESA® compliant displays with a 75 x 75 mm or 100 x 100 mm hole pattern. If your hole pattern does not match the VESA standard, call Customer Service to determine if Chief has a mount to fit your display.

HOW TO ORDER

1. Verify that your display is VESA® (75 x 75 mm or 100 x 100 mm) compliant. If your display does not match either of these hole patterns or to confirm compatibility, call Customer Service at 1.800.582.6480 (domestic) or 952.894.6280 (international).
2. Determine which mount fits your application needs and order the appropriate part number. If the mounts shown do not address your installation needs, call Customer Service about other possible combinations.
3. Verify that your display meets the specified weight capacity of the mount.
4. Determine color. Please specify S for silver or B for black after the model number. For example: If ordering a FWV-110 in silver, the part number would read FWV-110S.
5. Decide which accessories you will need for your installation.

Note: Interface brackets available for non-VESA® compliant displays.

RECOMMENDED ACCESSORIES

PAGE

FSA-1002 Desk Mount Adapter	83
FSA-1003* Extension Arm	83
FSA-1004* Extension Height-Adjustable Arm	83
FSA-1007 Centris™ Quick Release Interface	83
FSA-1009 Height-Adjustable Arm Security Hardware	83

*A maximum of three arms can be used.

SPECIFICATIONS

	FWV	FWG	FWB
Depth from Wall	2-3/16" (56 mm)	2-3/16" (56 mm)	2-3/16" (56 mm)
Wall Attachment Dimension WxHxD	7-3/8" x 5-11/16" x 1/8" (61 mm 145 x 46 mm)	7-3/8" x 5-11/16" x 1/8" (61 mm 145 x 46 mm)	7-3/8" x 5-11/16" x 1/8" (61 mm 145 x 46 mm)
Max. Extension	13" (330 mm)	19-1/2" (495 mm)	26" (66 cm)
Height Adjust.	13-1/4" (337 mm)	13-1/4" (337 mm)	13-1/4" (337 mm)
Pivot	180°	180°	180°
Color	Silver or Black	Silver or Black	Silver or Black
Weight Capacity	5-25 lbs (2.3-11.4 kg)	5-25 lbs (2.3-11.4 kg)	5-25 lbs (2.3-11.4 kg)

SMALL FLAT PANEL CENTRIS TECHNOLOGY – DESK MOUNTS

CUSTOM OR UNIVERSAL

FAQ

1. What if my display is not listed in the cross-reference chart?

A Chief's mounts fit VESA compliant displays with a 75 x 75 mm or 100 x 100 mm hole pattern. If your hole pattern does not match the VESA standard, call Customer Service to determine if Chief has a mount to fit your display.

HOW TO ORDER

1. Verify that your display is VESA® (75 x 75 mm or 100 x 100 mm) compliant. If your display does not match either of these hole patterns or to confirm compatibility, call Customer Service at 1.800.582.6480 (domestic) or 952.894.6280 (international).
 2. Determine which mount fits your application needs and order the appropriate part number. If the mounts shown do not address your installation needs, call Customer Service about other possible combinations.
 3. Verify that your display meets the specified weight capacity of the mount.
 4. Determine color. Please specify S for silver or B for black after the model number. For example: If ordering a FCS-110 in silver, the part number would read FCS110S.
 5. Decide which accessories you will need for your installation.
- Note: Interface brackets available for non-VESA® compliant displays.

FCS™-110/FCD™-110 SINGLE AND DUAL ARM DESK MOUNTS

Low-profile desk mount with swing arm for pivot and tilt adjustment. Perfect for home and office installations.



■ Exclusive Centris™ Technology

- Self-adjusts to support different display weights
- Enables effortless tilt and pivot
- Fingertip tilt and swivel for viewing at any angle

■ Easy Installation

Clamp option allows mount to be installed from the top of the mounting surface. Ships fully assembled!

■ Independently Adjustable Tension at Pivot Points

Provides customized control and can be optimized for touchscreens.

■ Maximum Pivot

At desk clamp, display connection and arm connection.

■ Portrait and landscape rotation and side-to-side pivot.



FCS-110 Single Arm Desk Mount.

■ Clean Look!

Minimal hardware visible from underside of work surface.

■ Multiple Mounting Options

- Edge clamp
6-3/16" x 5-1/8" x 4-3/16"
(157 x 130 x 107 mm)
- Grommet clamp
- Grommet thru-bolt

Note: Maximum mounting surface thickness: Up to 3-1/2" (89 mm). Grommet hole size: 3/8" – 3" (10 – 76 mm).



■ FCD-110 Dual Arm Wall Mount

Dual-arm design allows for increased extension and versatility.

SPECIFICATIONS

	FCS	FCD
Depth (closed)	2-3/16" (56 mm)	2-3/16" (56 mm)
Max. Extension	9-7/8" (251 mm)	16-3/8" (416 mm)
Dimensions WxHxD	5-5/8" x 7-5/8" x 7/8" (143 x 194 x 22 mm)	5-5/8" x 6-7/8" x 1-1/2" (143 x 175 x 38 mm)
Lateral Shift	2" (51 mm)	4" (102 mm)
Tilt	+/-15°	+/-15°
Pivot (Desk/Display/Arm)	360°/180°/0°	360°/180°/180°
Color	Silver or Black	Silver or Black
Weight Capacity	40 lbs (18.2 kg)	40 lbs (18.2 kg)

RECOMMENDED ACCESSORIES

	PAGE
FSA-1001 Wall Plate Adapter	83
FSA-1003* Extension Arm	83
FSA-1004* Extension Height-Adjustable Arm	83
FSA-1005 Arm Security Hardware Kit	83
FSA-1007 Centris™ Quick Release Interface	83

*A maximum of three arms can be used.

SMALL FLAT PANEL CENTRIS TECHNOLOGY – DESK MOUNTS

CUSTOM OR UNIVERSAL

FCV™-110/FCG™-110/FCB-110™ HEIGHT-ADJUSTABLE DESK MOUNTS

An ergonomic solution for the home or office providing excellent adjustability and extension.

HE

Easy Installation!
Ships fully assembled.

Exclusive Centris™ Technology
– Self-adjusts to support different display weights
– Enables effortless tilt and pivot
– Fingertip tilt and swivel for viewing at any angle

Multiple Mounting Options
– Edge clamp: 6-3/16" x 5-1/8" x 4-3/16" (157 x 130 x 107 mm)
– Grommet clamp
– Grommet thru-bolt

Portrait and landscape rotation and side-to-side pivot.

Extends 13-3/8"
(340 mm)

Built-in Cable Management
For a clean installation.

Note: Maximum mounting surface thickness: 3-1/2" (89 mm). Grommet hole size: 3/8" - 3" (10-76 mm).

Clean Look
Minimal hardware visible from underside of work surface.

FCV-110 Single Arm, Height Adjustable Desk Mount

FCG-110 Dual Arm Desk Mount
Dual arm design allows increased extension up to 20" (50.8 cm).

FCB-110 Triple Arm Desk Mount
Triple arm design allows for maximum extension up to 26-3/8" (67 cm).

FAQ

1. What if my display is not listed in the cross-reference chart?

A Chief's mounts fit VESA® compliant displays with a 75 x 75 mm or 100 x 100 mm hole pattern. If your hole pattern does not match the VESA standard, call Customer Service to determine if Chief has a mount to fit your display.

HOW TO ORDER

1. Verify that your display is VESA® (75 x 75 mm or 100 x 100 mm) compliant. If your display does not match either of these hole patterns or to confirm compatibility, call Customer Service at 1.800.582.6480 (domestic) or 952.894.6280 (international).
2. Determine which mount fits your application needs and order the appropriate part number. If the mounts shown do not address your installation needs, call Customer Service about other possible combinations.
3. Verify that your display meets the specified weight capacity of the mount.
4. Determine color. Please specify S for silver or B for black after the model number. For example: If ordering a FCV-110 in silver, the part number would read FCV-110S.

Note: Interface brackets available for non-VESA® compliant displays.

RECOMMENDED ACCESSORIES

PAGE

FSA-1002 Wall Plate Adapter	83
FSA-1003* Extension Arm	83
FSA-1004* Extension Height-Adjustable Arm	83
FSA-1007 Centris™ Quick Release Interface	83
FSA-1009 Height-Adjustable Arm Security Hardware	83

*A maximum of three arms can be used.

SPECIFICATIONS

	FCV	FCG	FCB
Depth (closed)	2-3/16" (56 mm)	2-3/16" (56 mm)	2-3/16" (56 mm)
Max. Extension	13-3/8" (340 mm)	20" (50.8 cm)	26-3/8" (67 cm)
Dimensions WxHxD	5-5/8" x 7-5/8" x 7/8" (143 x 194 x 22 mm)	5-5/8" x 7-5/8" x 7/8" (143 x 194 x 22 mm)	5-5/8" x 7-5/8" x 7/8" (143 x 194 x 22 mm)
Height Adjust.	13-1/4" (337 mm)	13-1/4" (337 mm)	13-1/4" (337 mm)
Pivot (Desk/Display/Arm)	360°/180°/0°	360°/180°/360°	360°/180°/360°
Color	Silver or Black	Silver or Black	Silver or Black
Weight Capacity	5-25 lbs (2.3-11.4 kg)	5-25 lbs (2.3-11.4 kg)	5-25 lbs (2.3-11.4 kg)



SMALL FLAT PANEL CENTRIS TECHNOLOGY – POLE MOUNTS

CUSTOM OR UNIVERSAL

FAQ

1. What if my display is not listed in the cross-reference chart?

A Chief's mounts fit VESA® compliant displays with a 75 x 75 mm or 100 x 100 mm hole pattern. If your hole pattern does not match the VESA standard, call Customer Service to determine if Chief has a mount to fit your display.

HOW TO ORDER

1. Verify that your display is VESA® (75 x 75 mm or 100 x 100 mm) compliant. If your display does not match either of these hole patterns or to confirm compatibility, call Customer Service at 1.800.582.6480 (domestic) or 952.894.6280 (international).
2. Determine which mount fits your application needs and order the appropriate part number.
3. Verify that your display meets the specified weight capacity of the mount.
4. Determine color. Please specify S for silver or B for black after the model number. For example: If ordering a FPP-110 in silver, the part number would read FPP-110S.

Note: Interface brackets available for non-VESA compliant displays.

FPP™-110/FPS™-110/FPD™-110 PIVOT/TILT, SINGLE AND DUAL ARM MOUNTS

Easily attaches displays to 1-1/2" to 2" OD poles and provides smooth pivot and tilt adjustments.

HE

Easy Height Adjustment
By adjusting a single screw.

Portrait and landscape rotation and side-to-side pivot.

Exclusive Centris™ Technology
– Self-adjusts to support different display weights
– Enables effortless tilt and pivot
– Fingertip tilt and swivel for viewing at any angle

Friction-adjustable pivot points for customized movement.

VESA® Compliant

Extends 10" (240 mm)
FPS Single Arm Pivot/Tilt Pole Mount

Flexible Installation!
Allows installation on pre-existing poles. Ships fully assembled!



FPP Pivot/Tilt Pole Mount
Easy to attach. Provides smooth pivot and tilt.

FPD Dual Arm Pivot/Tilt Pole Mount
Allows increased extension, up to 15-15/16" (405 mm).

SPECIFICATIONS

	FPP	FPS	FPD
Depth from Pole	2-15/16" (74 mm)	2-1/8" (56 mm)	2-1/8" (56 mm)
Max. Extension	NA	9-7/16" (24 cm)	15-15/16" (40.4 cm)
Dimensions WxHxD	6-3/8" x 4-11/16" x 4-3/16" (161 x 119 x 106 mm)	8-13/16" x 4-11/16" x 11-1/4" (224 x 119 x 285 mm)	11-1/4 x 4-11/16 x 17-3/4" (287 x 119 x 435 mm)
Tilt	+/-15°	+/-15°	+/-15°
Pivot (Pole, Arm, Display)	360°/0°/180°	360°/180°/180°	360°/180°/180°
Color	Silver or Black	Silver or Black	Silver or Black
Weight Capacity	40 lbs (18.2 kg)	40 lbs (18.2 kg)	40 lbs (18.2 kg)

RECOMMENDED ACCESSORIES

PAGE

FSB Bracket* (for non VESA compliant displays)	
FSA-1005 Arm Security Hardware Kit	83
*See Chief's Cross-Reference list available at www.chiefmfg.com	

SMALL FLAT PANEL CENTRIS TECHNOLOGY – CEILING MOUNTS

CUSTOM OR UNIVERSAL

FHP™-110 CEILING MOUNT WITH ADJUSTABLE COLUMN

A sleek solution for small flat panel ceiling installations. Perfect for homes to retail applications.

Complete Assembly Package

Includes ceiling plate, adjustable extension column, two plastic snap-on cable management covers, and pivot/tilt attachment for a variety of screen positioning options. (Ceiling plate hardware not included)

Includes CMA-101
Ceiling Plate

Portrait and landscape rotation and side-to-side pivot.

Built-In Cable Management

Cable management system with snap-on cable cover (one included).

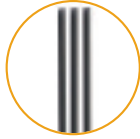

Exclusive Centris™ Technology

- Self-adjusts to support different display weights
- Enables effortless tilt and pivot
- Fingertip tilt and swivel for viewing at any angle



FAQ

1. What if my display is not listed in the cross-reference chart?

A Chief's mounts fit VESA® compliant displays with a 75 x 75 mm or 100 x 100 mm hole pattern. If your hole pattern does not match the VESA standard, call Customer Service to determine if Chief has a mount to fit your display.

HOW TO ORDER

1. Verify that your display is VESA® (75 x 75 mm or 100 x 100 mm) compliant. If your display does not match either of these hole patterns or to confirm compatibility, call Customer Service at 1.800.582.6480 (domestic) or 952.894.6280 (international).
2. Determine which mount fits your application needs and order the appropriate part number.
3. Verify that your display meets the specified weight capacity of the mount.
4. Determine color. Please specify S for silver or B for black after the model number. For example: If ordering a FHP-110 in silver, the part number would read FHP-110S.

Note: Interface brackets available for non-VESA compliant displays.

RECOMMENDED ACCESSORIES

PAGE

FSB Bracket* (for non VESA compliant displays)	
CMA-275 Quick-Snap Cable Cover	83
FSA-1005 Arm Security Hardware Kit	83
UMA-1051 1" (25.4 mm) Coupler	83

*See Chief's Cross-Reference list available at www.chiefmfg.com

SPECIFICATIONS

Ceiling Plate	5" x 5" (127 x 127 mm)
Dimensions	8-3/16" x 12-3/16" x 2-1/8" (208 x 310 x 54 mm)
Height Adjust.	23"–42" (58 – 107 cm)
Tilt	+/- 15°
Pivot	360°
Color	Silver or Black
Weight Capacity	40 lbs (18.2 kg)

SMALL FLAT PANEL ARRAYS

CUSTOM OR UNIVERSAL

FAQ

1. What if my display is not listed in the cross-reference chart?

A Chief's mounts fit VESA® compliant displays with a 75 x 75 mm or 100 x 100 mm hole pattern. If your hole pattern does not match the VESA standard, call Customer Service to determine if Chief has a mount to fit your display.

HOW TO ORDER

1. Verify that your screen is VESA® compliant (must order a separate FSB interface bracket for non-VESA® compliant displays).
2. Verify that your display meets the weight capacity.
3. Fax or e-mail your order to Customer Service at 877.894.6918 (domestic), 952.894.6918 (international) or orders@chiefmfg.com.

FMA™-220 DUAL ARRAY / FMA™-320 TRIPLE ARRAY

View multiple small flat panel displays side-by-side with the array accessories. Perfect for broadcast production rooms, graphic agencies to financial trading desks.

HE

■ Independent Adjustment

Position each screen separately for proper ergonomic alignment.

■ Install in Portrait or Landscape Positions.

■ VESA® Compliant

75 mm x 100 mm. Interface brackets available for non-VESA compliant displays.

■ Centris TurnTite™ Dials

Lock screen adjustments in place for proper alignment.

■ Built-in Cable Management

Adjustable cable management clips on arm help collect multiple cables.

■ Exclusive Centris™ Technology

- Self-adjusts to support different display weights
- Enables effortless tilt and pivot
- Fingertip tilt and swivel for viewing at any angle

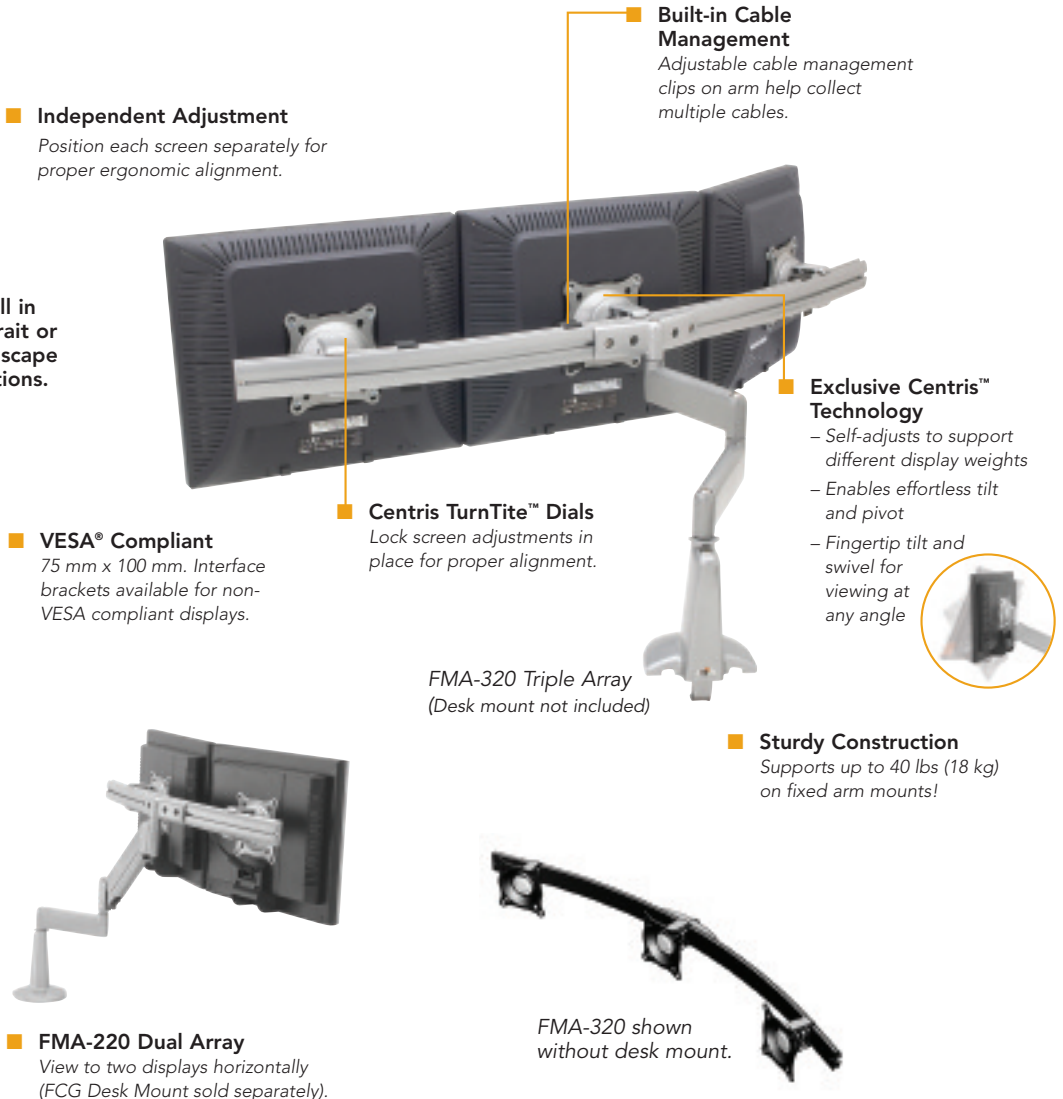

FMA-320 Triple Array (Desk mount not included)

■ FMA-220 Dual Array

View to two displays horizontally (FCG Desk Mount sold separately).

■ Sturdy Construction

Supports up to 40 lbs (18 kg) on fixed arm mounts!

COMMON APPLICATIONS

Mount multiple displays side-by-side for maximum efficiency and increased organization:

Graphic Illustration

Financial Trading

Broadcasting

Call Centers

SPECIFICATIONS

Model:

	FMA-220	FMA-320
Depth from Wall	6-3/8" (162 mm) – Centris cups at ends 5-3/8" (137 mm) – Centris cups in middle	8-1/4" (210 mm) – Centris cups at ends 7-1/4" (184 mm) – Centris cups in middle
Tilt	+/- 15°	+/- 15°
Color	Silver or Black	Silver or Black
Weight of Array	6.5 lbs (2.9 kg)	9.5 lbs (4.3 kg)
Weight Capacity	33 lbs (15 kg) – Fixed arm mounts 18 lbs (8 kg) – Height-adjustable mounts	30 lbs (14 kg) – Fixed arm mounts Not recommended for height-adjustable mounts

FMA-320

8-1/4" (210 mm) – Centris cups at ends
7-1/4" (184 mm) – Centris cups in middle
+/- 15°
Silver or Black
9.5 lbs (4.3 kg)
30 lbs (14 kg) – Fixed arm mounts
Not recommended for height-adjustable mounts

SMALL FLAT PANEL

NOTES

NOTES:

SMALL FLAT PANEL ACCESSORIES

For FSP, FDP, FPP, FPS and FPD Mounts only.

CEILING PLATES

CMA™-100 8" (203 mm) CEILING PLATE WITH ATTACHED ADJUSTABLE 1-1/2" (32 MM) NPT COLUMN

- Universal solution for most structural ceiling installations
- Easy way to achieve the desired drop distance, 24-1/4"-46" (61.6-116.8 cm)
- Adjustable in 3/4" (19 mm) increments
- Weight Capacity: 500 lbs (227 kg)
- Now available in black, white or silver



CMA™-101 5" (127 mm) DESIGNER CEILING PLATE WITH 1-1/2" (32 MM) NPT OPENING

- Easy to install
- Mount using all four holes or two opposing holes
- 4" x 4" (102 x 102 mm) mounting pattern is designed to allow use of 3/8" (10 mm) mounting bolts
- Attaches to a 1-1/2" (38.1 mm) NPT threaded extension column
- Weight Capacity: 500 lbs (227 kg)



CMA™-105 4" (102 mm) / CMA™-115 6" (152 mm) / CMA™-110 8" (203 mm) CEILING PLATE WITH 1-1/2" NPT OPENING

- Combines with any CMA Adjustable Extension Column or CMA Fixed Extension Column
- Includes set screw
- Weight Capacity: 500 lbs (227 kg)



CMA™-330 OFFSET CEILING PLATE

- Routes cables through the extension column and out the top of the ceiling plate for cable management
- Includes an 8" (203 mm) square ceiling plate with a 1-3/4" (45 mm) high offset
- Overall Height: 4-1/16" (103 mm)
- Attaches to 1-1/2" NPT extension column
- Weight Capacity: 500 lbs (227 kg)
- Also available for attaching to 2" NPT, order CMA-332



EXTENSION COLUMNS

CMA™ ADJUSTABLE EXTENSION COLUMNS

- Use with any 1-1/2" NPT accessory to lower the projector
- Provides a range of height adjustment in 1" (25 mm) increments
- Includes set screw for added rigidity
- Weight Capacity: 500 lbs (227 kg)



Model	Length	Model	Length
CMA-006009	6"-9" (152-229 mm)	CMA-0507	5'-7' (1.5-2.1 m)
CMA-009012	9"-12" (229-305 mm)	CMA-0608	6'-8' (1.8-2.4 m)
CMA-012018*	12"-18" (305-457 mm)	CMA-0709	7'-9" (2.1-2.7 m)
CMA-018024	18"-24" (457-610 mm)	CMA-0810	8'-10' (2.4-3.1 m)
CMA-0203	2'-3' (0.6-0.9 m)	CMA-0911	9'-11' (2.7-3.4 m)
CMA-0305	3'-5' (0.9-1.5 m)	CMA-1012**	10'-12' (3.1-3.7 m)
CMA-0406	4'-6' (1.2-1.8 m)		

* Now available in black, white or silver. To order this accessory in white or silver, simply add a "W" for white or an "S" for silver to the end of the part number.

** Note: CMA1012 Adjustable Extension Column cannot ship by UPS due to length.

CMA™ FIXED EXTENSION COLUMNS

- Use with any 1-1/2" (32 mm) NPT accessory to lower the projector
- Includes 1-1/2" (32 mm) NPT column threaded on both ends, 3'-6' (0.9-1.8 m) lengths
- Weight Capacity: 500 lbs (227 kg)



Model	Length	Model	Length
CMA-003	3" (76 mm)	CMA-024	2' (0.6 m)
CMA-006*	6" (152 mm)	CMA-036	3' (0.9 m)
CMA-008	8" (203 mm)	CMA-048	4' (1.2 m)
CMA-012	12" (305 mm)	CMA-060	5' (1.5 m)
CMA-018	18" (457 mm)	CMA-072	6' (1.8 m)

* Now available in black, white or silver. To order this accessory in white or silver, simply add a "W" for white or an "S" for silver to the end of the part number.

INSTALLATION ADAPTERS

CMA™-151 1" (25 mm) TO 1-1/2" (32 MM) NPT ADAPTER/REDUCER

- Adapts 1-1/2" NPT accessory for use with a 1" (25 mm) NPT column



SMALL FLAT PANEL ACCESSORIES

OTHER INSTALLATION ADAPTERS

FSA™-1001 WALL PLATE ADAPTER

- Can be used to quickly change a desk mount into a wall mount
- Specify black or silver when ordering



FSA™-1002 DESK MOUNT ADAPTER

- Can be used to quickly change a wall mount into a desk mount
- Specify black or silver when ordering



FSA™-1003 EXTENSION ARM

- Attaches to single or dual arm mounts and pivot/tilt wall mounts for additional extension
- Specify black or silver when ordering



FSA™-1004 EXTENSION HEIGHT ADJUSTABLE ARM

- Attaches to any single or dual arm mount for height adjustment and additional extension
- Not compatible with lifting arm solutions
- Specify black or silver when ordering



FSA™-1007 CENTRIS QUICK RELEASE INTERFACE

- Small flat panel quick release bracket
- To complete installation you must order the correct interface bracket
- Specify black or silver when ordering



For more information about the following accessories, please visit www.chiefmfg.com.

- CMA™-275 Quick-Snap Cable Cover
- CMA™-440 Lightweight Suspended Ceiling Kit
- CMA™-450 Suspended Ceiling Kit
- CMA™-455 Suspended Ceiling Replacement Kit
- UMA™-1051 1" (25 mm) Coupler
- FSA™-1006 Extreme Pitch Accessory

SECURITY ACCESSORIES

FSA™-1000 Q2™ MOUNTING SYSTEM LOCKABLE LATCH

- Lockable latch for FSM, FPM, FSP and FDP small flat panel display mounts
- Includes adaptable accessory flag and set screw
- Compatible with padlocks
- Specify black or silver when ordering



FSA™-1005 ARM SECURITY HARDWARE KIT

- Replaces exposed hardware on any small flat panel arm configuration with security hardware
 - Specify black or silver when ordering
- Note: Not compatible with height-adjustable arm mounts*



FSA™-1009 HEIGHT-ADJUSTABLE ARM SECURITY HARDWARE KIT

- Replaces exposed hardware on any small flat panel height-adjustable arm configuration with security hardware
- Specify black or silver when ordering

SSC™ SECURITY SCREW COVER KITS

- Provides added protection against equipment theft
- Prohibits access to screws by covering hardware and locking with padlocks or cable
- Three kits available:
 - SSC-1 includes three covers for screws up to #10 (M5)
 - SSC-2 includes three covers for screws up to 1/4" (M6)
 - SSC-3 includes three covers for screws up to 5/16" (M8)
- Padlocks and cable not included





SECTION 5 LIFTS



Chief Projector and Large Flat Panel Display Lifts are custom mounts designed for unique installations. Secure construction, easy-to-use features and the latest in mounting technology make these lifts the perfect choice to conceal equipment in the ceiling or in a custom-built enclosure. Chief's lift designs create an attractive installation that can be seen, and then quietly and smoothly retracted with the press of a button.

HOW TO CHOOSE A LIFT

Chief's innovative lifts are easy to use and create an attractive installation. Top-selling features of the projector and large flat panel lifts include:

- Easy installation with support available from Chief's qualified Customer Service Team
- Independent adjustments offer quick installation by allowing each adjustment to be tightened or refined separately
- Multiple mounting options
- Easy maintenance

CONTROL DEVICES

With all Chief lifts, it is possible to wire more than one control device. As long as you aren't using latching switches, it is easy to piggyback systems. Chief lifts also allow you to control another device, like a motorized screen, by using the lift's low-voltage controller which provides two dry latching contacts.



Q-LATCH™ MOUNTING SYSTEM

Chief's Q-Latch Mounting System safely secures screens to the mount in three easy steps and is included with the large flat panel lifts. With the Q-Latch System, simply lift and set the screen on the mount for a firm, safe connection.



CHIEF ADDS VALUE TO EVERY MOUNT WE MAKE.

End-User Focused

■ Customer-Friendly Designs

- Independent roll, pitch & yaw for easy adjustments
- Multiple control options for easy operation
- Low-profile design makes for a clean installation

■ Complete Solution

Compatible with multiple accessories to customize any installation.

■ Exclusive Auto-Tilt™ (PCL)

Automatically tilts display to desired angle as the display lowers.

Proven Quality

■ Industry Leader

27 years of engineering excellence.

■ Solid Steel Construction

Designed with heavy-gauge steel.

■ Rigorous Testing

Every mount undergoes a series of tests to ensure a safe and secure installation.

■ Custom Solutions

Chief custom designs solutions for the perfect fit.

Faster Installation

■ Voltage Options

Avoid costly rewiring with multiple voltage options.

■ Q-Latch™ Mounting System (PUL/PCL)

Safely and easily secures the mount and locks it into place.

■ Multiple Mounting Options

Choose the best solution for your installation.

Superior Service

■ Expert and Accessible Customer Service

- Knowledgeable support from experienced industry professionals
- Order tracking to technical issues in one phone call.

■ On-Time Delivery

Most products ship within 24 hours after receipt of purchase order.



The exclusive Auto-Tilt feature on Chief's PCL Electric Ceiling Lift provides automatic tilt as the display is lowered.



Solid Steel Construction allows ultimate durability for lifts like SL-150 Smart Lift™.



Chief's patented Q-Latch Mounting System allows installation in 3 easy steps.



Emma Halls, Chief Customer Service makes sure your order ships within 24 hours.

NOTES:

PROJECTOR LIFTS

SL-150 SMART-LIFT™
Projector Lift

PG 88



MAX WEIGHT: 35 lbs **W**

SL-236 SMART-LIFT™
Projector Lift

PG 89



MAX WEIGHT: 35 lbs **W**

FLAT PANEL LIFTS

PUL™
Electric Pop-Up Lift

PG 90



MAX WEIGHT: 230 lbs **B**

PCL™
Electric Ceiling Lift

PG 91



MAX WEIGHT: 230 lbs **B**

See page 92 for a complete list of lift accessories.

LIFTS PROJECTOR

CUSTOM SOLUTION

FAQ

1. How do I mount my projector to the lift?

A One SLB bracket is required to attach the projector to the lift. The SLB bracket is a separate part number and is used only for Chief lifts. Order the same suffix as the RPA, but use an SLB prefix.

2. What do I need to control the lift with AMX/Crestron type systems?

A Two dry contacts are necessary, one dedicated for extend and one for retract.

3. Can I wire more than one control device?

A Yes, you can piggyback systems as long as you are not using latching switches.

4. Can I control another device, such as a screen, by using the lift's low voltage controller?

A Yes, Chief's controller provides two dry latching contacts to control another device.

HOW TO ORDER

- Determine the appropriate SLB bracket by looking in the cross-reference chart. For the most recent cross-reference, visit www.chiefmfg.com or call Customer Service at 1.800.582.6480 (domestic) or 952.894.6280 (international).
- Verify that the projector will fit inside the lift.
- Decide if you will need additional accessories for your installation.

SL-150 SMART-LIFT™

A sophisticated solution offering exceptionally smooth and quiet movement. Perfect for homes and corporate offices.

HE

Independent Projector Roll, Pitch & Yaw

Easy adjustments for precise image registration.

Precise Positioning

- Vertical projector cradle adjustment
- Fore/aft, left/right projector positioning

Multiple Control Options

- Single Momentary Pushbutton
- Low Voltage Controller
- Internal & External Wiring Options

Flexible Installation

- Comes ready for a finished ceiling installation
- Accommodates suspended ceilings with optional CMA-240 Accessory

Quick Connect/Disconnect

Maintains registration even when disconnected.

Voltage Options

- 120V or 230V (for 230V order SL-150I)
- Accepts 5-30V AC/DC for triggering commands

3 Mounting Options:

- Three 3/8" (10 mm) Threaded Rods
- 1-1/2" NPT Extension Column with SMA-600; provides 1-1/2" (38 mm) horizontal adjustment
- Side mounting with the built-in joist tabs (allows installation into wood framed ceilings)

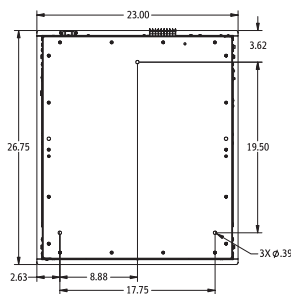

TOP VIEW

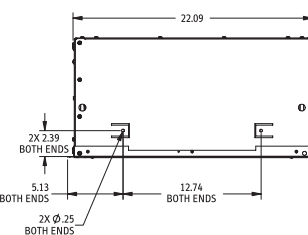

FRONT VIEW

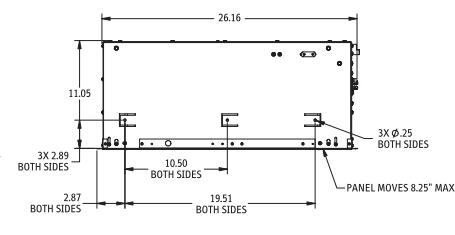

SIDE VIEW

Note: All electrical components are CE approved, and UL, CSA and VDE listed.

SPECIFICATIONS

Model	Roll/Pitch/Yaw (+/-)	Travel Distance*	Maximum Equipment Size W x H x D	Overall Dimensions W x H x D	Ceiling Opening W x D	Ceiling Closure W x D	Color	Current Draw	Weight Capacity	Net Weight
SL-150	2°/12°/5°	8-1/4" (210 cm)	18" x 9-1/2" x 22-1/4" (458 x 241 x 565 mm)	22-1/8" x 11" x 26-1/8" (56.2 x 27.9 x 66.4 cm)	22" x 25-3/4" (55.8 x 65.4 cm)	19-5/8" x 22-3/8" (49.9 x 59.4 cm)	White	0.9 amps	35 lbs (16 kg)	66 lbs (30 kg)

* Travel distance is non-adjustable.

RECOMMENDED ACCESSORIES

PAGE

SLB (Required) Refer to cross-reference chart
CMA Fixed and Adjustable Extension Columns
CMA-240 Suspended Ceiling Finishing Kit

92
92
92

IR-10 Infrared Remote Control
RC-10 Radio Frequency Remote Control
SMA-600 Single Column Mounting Plate
UPB-1 Upright Projector Bracket

PAGE

92
92
92
92

CUSTOM SOLUTION

SL-236 SMART-LIFT™

Perfect for electrically lowering projectors from high ceilings in corporate offices and sophisticated homes.

HE

Flexible Installation

Suitable for finished or suspended ceilings.

Independent Projector Roll, Pitch & Yaw

Easy adjustments for precise image registration.

Precise Positioning

- Vertical projector cradle adjustment
- Fore/aft, left/right projector positioning

Control Options

- Single Momentary Pushbutton
- Low Voltage Controller
- Internal & External Wiring Options

Low Profile

- Requires only 11" (279 mm) clearance above the ceiling
- 36" (91.4 cm) of travel distance with three stopping positions (up/show/service)

Quick Connect/Disconnect

Maintains registration even when disconnected.

Cable Management

For a clean installation.

Voltage Options

- 120V or 230V (for 230V order SL-236I)
- Accepts 5-30V AC/DC for triggering commands

4 Mounting Options:

1. Four 3/8" (10 mm) threaded rods with SMA-650 Accessory for accurate leveling
2. 1-1/2" NPT extension column with SMA-600 Accessory
3. Side mounting with the built-in joist tabs to mount in wood framed ceilings
4. Suspended by cables with SMA-650 Accessory

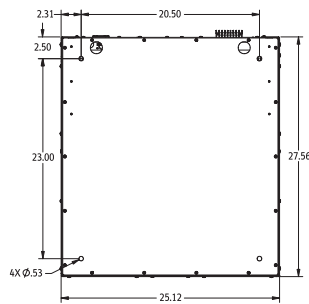

TOP VIEW (SL-236SP)

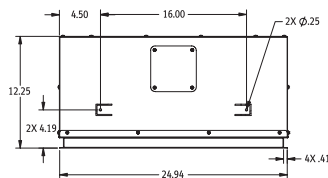

FRONT VIEW (SL-236SP)

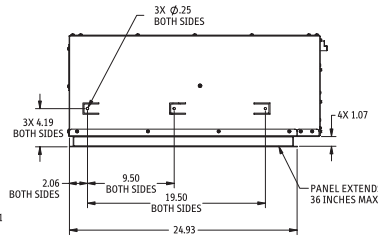

SIDE VIEW (SL-236SP)

Note: All electrical components are UL, CSA and VDE listed.

SPECIFICATIONS

Model	Roll/Pitch/Yaw (+/-)	Travel Distance*	Maximum Equipment Size W x H x D	Overall Dimensions W x H x D	Ceiling Opening W x D	Ceiling Closure W x D	Color	Current Draw	Weight Capacity	Net Weight
SL-236	2°/15°/10°	36" (91.4 cm)	20-1/2" x 9-1/4" x 22-3/4" (52.1 x 23.5 x 57.8 cm)	25" x 11" x 27-1/2" (63.5 x 27.9 x 69.8 cm)	25-1/2" x 28" (64.1 x 71 cm)	24" x 24" (61 x 61 cm)	White	0.75 amps	35 lbs (16 kg)	85 lbs (38.6 kg)

*Travel distance is adjustable.

RECOMMENDED ACCESSORIES

SLB (Required) Refer to cross-reference chart
 IR-10 Infrared Remote Control
 RC-10 Radio Frequency Remote Control
 SMA-600 Single Column Mounting Plate

PAGE

92
92
92
92

SMA-620 Suspended Column Mounting Plate
 CMA-650 Threaded Rod Adapter
 UPB-1 Upright Projector Bracket

PAGE

92
92
92

FAQ

1. How do I mount my projector to the lift?

A One SLB bracket is required to attach the projector to the lift. The SLB bracket is a separate part number and is used only for Chief lifts. Order the same suffix as the RPA, but use an SLB prefix.

2. What do I need to control the lift with AMX/Crestron type systems?

A Two dry contacts are necessary, one dedicated for extend and one for retract. A third contact may be added for the service position.

3. How do I adjust the "show" position?

A Adjust the limit switch located in the outside bottom corner of the lift with a screwdriver. Adjusts within a travel range of 4"–36" (10.2–91.4 cm).

4. How do I service my projector?

A Extend the lift to the service position. The center cradle removes for easy projector access without losing registration.

HOW TO ORDER

1. Determine the appropriate SLB bracket by looking in the cross-reference chart. For the most recent cross-reference, visit www.chiefmfg.com or call Customer Service at 1.800.582.6480 (domestic) or 952.894.6280 (international).

2. Verify that the projector will fit inside the lift.

3. Specify what type of ceiling you have at the end of the part number (FD for finished, SP for suspended).

4. Decide if you will need additional accessories for your installation.

* Note: The SL-236 Lift ships by truck.



LIFTS

LARGE FLAT PANEL

CUSTOM SOLUTION

FAQ

1. Do I need to order a separate interface bracket?

A Yes, you will need one PSB bracket for each display. Find the make and model of your large flat panel display in the cross-reference chart, then look in the Mounting Bracket column.

2. What do I need to control AMX/Crestron type control systems?

A Two dry contacts are necessary, one dedicated for extend and one for retract.

HOW TO ORDER

- Determine the travel distance required for your application and the dimensions of your large flat panel display.
- Find the correct interface bracket for your display by looking in the cross-reference chart. For the most recent cross-reference chart, visit www.chieffmfg.com or call Customer Service at 1.800.582.6480 (domestic) or 952.894.6280 (international).
- Order the appropriate PUL model. All models are available in 115V, 60 Hz, 1.5 amps OR 230V, 50 Hz, 0.8 amps continuous.

* Note: The PUL lift ships by truck.

PUL™ ELECTRIC POP-UP LIFT

Quiet movement and smooth operation make this lift ideal for high profile home and office installations.

HE

Flexible Screen Positioning

Display installs in portrait or landscape positions.

Integrated Display Attachment System

Allows you to replace an old display without reconfiguring the lift or redesigning cabinetry.

Quiet Operation with Adjustable Travel Distance.

Control Options

- Single Momentary Pushbutton (included)
- Low Voltage Controller (included)

Accessories

- PAC-140 Q-Clamp (included)
- SS-10 Safety Strip (not included)
- PSB interface bracket (not included)

Notes:

- All electrical components are UL, CSA and VDE listed
- For information on Accessories for this product, see page 92.

Voltage Options

- 120V or 230V
- Will accept 5–30V AC/DC for triggering commands

Exclusive Q-Latch™ Mounting System

- Offers quick connect/disconnect
- Secures display with a lockable latch



Quick, Smooth Movement

Travel speed approximately 1" (25 mm) per second.

Reliable Operation

Chain-driven system keeps motor at the bottom of the lift, making operation smooth and quiet.



Min & Max Outside Adjustable Width

44-1/4"– 56-1/4" (112–143 cm)

Min & Max Inside Adjustable Width

42-1/4"– 54-1/4" (107–138 cm)

SPECIFICATIONS

Model	Travel Distance	Maximum Equipment Size W x H x D	Outside Dimensions H x D	Voltage	Color	Weight Capacity
PUL-4224	24" (61 cm)	54-1/8" x 21-1/2" x 6-1/2" (137.5 x 54.6 x 16.5 cm)	29-3/4" x 8-1/2" (75.6 x 21.6 cm)	120V or 230V	Black	230 lbs (104.3 kg)
PUL-4228	28" (71 cm)	54-1/8" x 25-1/2" x 6-1/2" (137.5 x 64.7 x 16.5 cm)	33-3/4" x 8-1/2" (85.7 x 21.6 cm)	120V or 230V	Black	230 lbs (104.3 kg)
PUL-4233	33" (83.8 cm)	54" x 30-1/2" x 6-1/2" (137.5 x 77.5 x 16.5 cm)	38-3/4" x 8-1/2" (98.4 x 21.6 cm)	120V or 230V	Black	230 lbs (104.3 kg)
PUL-4239	39" (99 cm)	54-1/8" x 36-1/2" x 6-1/2" (137.5 x 92.7 x 16.5 cm)	44-3/4" x 8-1/2" (113.7 x 21.6 cm)	120V or 230V	Black	230 lbs (104.3 kg)
PUL-4245	45" (114.3 cm)	54-1/8" x 42-1/2" x 6-1/2" (137.5 x 108 x 16.5 cm)	50-3/4" x 8-1/2" (128.9 x 21.6 cm)	120V or 230V	Black	230 lbs (104.3 kg)
PUL-4251	51" (129.5 cm)	54-1/8" x 48-1/2" x 6-1/2" (137.5 x 123.2 x 16.5 cm)	56-3/4" x 8-1/2" (144.2 x 21.6 cm)	120V or 230V	Black	230 lbs (104.3 kg)
PUL-4257	57" (144.8 cm)	54-1/8" x 54-1/2" x 6-1/2" (137.5 x 138.4 x 16.5 cm)	62-3/4" x 8-1/2" (159.4 x 21.6 cm)	120V or 230V	Black	230 lbs (104.3 kg)

CUSTOM SOLUTION

PCL™ ELECTRIC CEILING LIFT

Hides large flat panel displays in ceilings and smoothly lowers at the push of a button or command of a control system – an impressive solution for high profile homes or businesses.

HE

Smooth, Quiet Travel.

Hidden Installation

Covered ceiling opening in closed position.

Voltage Options

- 120V or 230V
- Will accept 5–30V AC/DC for triggering commands

Exclusive Q-Latch™ Mounting System

- Offers quick connect/disconnect
- Secures display with a lockable latch



Integrated Cable Management

For a clean installation.



Exclusive Auto-Tilt™

Automatically tilts display to desired angle as display lowers.

2 Mounting Methods:

1. Four 3/8" (10 mm) threaded rods attach to top of lift for precise leveling
2. Side mounting by bolting to wood framed structure

Adjustable travel limit to set your viewing position.



Control Options

- Single Momentary Pushbutton (included)
- Low Voltage Controller (included)

Notes:

- All electrical components are UL, CSA and VDE listed
- PSB interface bracket not included
- For information on Accessories for this product, see page 92

FAQ

1. Do I need to order a separate interface bracket?

A Yes, you will need one PSB bracket for each display. Find the make and model of your display in the cross-reference chart, then look in the Mounting Bracket column.

2. What do I need to control AMX/Crestron type control systems?

A Two dry contacts are necessary, one dedicated for extend and one for retract.

3. Can I wire more than one control device?

A Yes, you can piggyback systems as long as you are not using latching switches.

HOW TO ORDER

1. Determine the travel distance required for your application and the dimensions of your large flat panel display.
2. Find the correct interface bracket for your display by looking in the cross-reference chart. For the most recent cross-reference chart, visit www.chiefmfg.com or call Customer Service at 1.800.582.6480 (domestic) or 952.894.6280 (international).
3. Order the appropriate PCL model. All models are available in 115V, 60 Hz, 1.5 amps OR 230V, 50 Hz, 0.8 amps continuous.

* Note: The PCL lift ships by truck.

SPECIFICATIONS

Model	Tilt	Travel Distance	Maximum Equipment Size W x H x D	Minimum Ceiling Clearance	Ceiling Opening W x D	Color	Weight Capacity
PCL-4233T	0°, 5°, 10°, 15°	33" (83.8 cm)	42-5/8" x 29" x 6" (108.3 x 73.7 x 15.2 cm)	40-1/4" (102.2 cm)	48-13/16" x 9-1/4" (124 x 23.5 cm)	Black	230 lbs (104.3 kg)
PCL-4239T	0°, 5°, 10°, 15°	39" (99 cm)	42-5/8" x 31-1/2" x 6" (108.3 x 80 x 15.2 cm)	46-1/4" (117.5 cm)	48-13/16" x 9-1/4" (124 x 23.5 cm)	Black	230 lbs (104.3 kg)
PCL-4245T	0°, 5°, 10°, 15°	45" (114.3 cm)	42-5/8" x 31-1/2" x 6" (108.3 x 80 x 15.2 cm)	52-1/4" (132.7 cm)	48-13/16" x 9-1/4" (124 x 23.5 cm)	Black	230 lbs (104.3 kg)
PCL-4251T	0°, 5°, 10°, 15°	51" (129.5 cm)	42-5/8" x 31-1/2" x 6" (108.3 x 80 x 15.2 cm)	58-1/4" (148 cm)	48-13/16" x 9-1/4" (124 x 23.5 cm)	Black	230 lbs (104.3 kg)
PCL-5033T	0°, 5°, 10°, 15°	33" (83.8 cm)	50" x 29" x 6" (127 x 73.4 x 15.2 cm)	40-1/4" (102.2 cm)	56-3/16" x 9-1/4" (142.7 x 23.5 cm)	Black	230 lbs (104.3 kg)
PCL-5039T	0°, 5°, 10°, 15°	39" (99.1 cm)	50" x 31-1/2" x 6" (127 x 80 x 15.2 cm)	46-1/4" (117.5 cm)	56-3/16" x 9-1/4" (142.7 x 23.5 cm)	Black	230 lbs (104.3 kg)
PCL-5045T	0°, 5°, 10°, 15°	45" (114.3 cm)	50" x 31-1/2" x 6" (127 x 80 x 15.2 cm)	52-1/4" (132.7 cm)	56-3/16" x 9-1/4" (142.7 x 23.5 cm)	Black	230 lbs (104.3 kg)
PCL-5051T	0°, 5°, 10°, 15°	51" (129.5 cm)	50" x 31-1/2" x 6" (127 x 80 x 15.2 cm)	58-1/4" (148 cm)	56-3/16" x 9-1/4" (142.7 x 23.5 cm)	Black	230 lbs (104.3 kg)

LIFTS ACCESSORIES

EXTENSION COLUMNS

CMA™ ADJUSTABLE EXTENSION COLUMNS

- Weight Capacity: 500 lbs (227 kg)



Model	Length	Model	Length
CMA-006009	6"-9" (152-229 mm)	CMA-0507	5'-7' (1.5-2.1 m)
CMA-009012	9"-12" (229-305 mm)	CMA-0608	6'-8' (1.8-2.4 m)
CMA-012018*	12"-18" (305-457 mm)	CMA-0709	7'-9' (2.1-2.7 m)
CMA-018024	18"-24" (45.7-61 cm)	CMA-0810	8'-10' (2.4-3.1 m)
CMA-0203	2'-3' (0.6-0.9 m)	CMA-0911	9'-11' (2.7-3.4 m)
CMA-0305	3'-5' (0.9-1.5 m)	CMA-1012**	10'-12' (3.1-3.7 m)
CMA-0406	4'-6' (1.2-1.8 m)		

* Now available in black, white or silver. To order this accessory in white or silver, simply add a "W" for white or an "S" for silver to the end of the part number.

**CMA1012 Adjustable Extension Column cannot ship by UPS due to length.

CMA™ FIXED EXTENSION COLUMNS

- Weight Capacity: 500 lbs (227 kg)



Model	Length	Model	Length
CMA-003	3" (76 mm)	CMA-024	2' (0.6 m)
CMA-006	6" (152 mm)	CMA-036	3' (0.9 m)
CMA-008	8" (203 mm)	CMA-048	4' (1.2 m)
CMA-012	12" (305 mm)	CMA-060	5' (1.5 m)
CMA-018	18" (457 mm)	CMA-072	6' (1.8 m)

CONTROL ACCESSORIES

IR™-10 INFRARED REMOTE CONTROL

- Can be used to control any Chief lift
- Up/down service function



RC™-10 RADIO FREQUENCY REMOTE CONTROL

- Can be used to control any Chief lift
- Up/down service function



ASP™-401 INDIVIDUAL CONTROL SYSTEM

- Allows up/down intermediate break by rocker switch



For more information about the following accessories, please visit www.chiefmfg.com.

SLB (REQUIRED)

See Chief's cross-reference chart.

CMA-240

- Suspended Ceiling Finishing Kit
Provides a finished look to the T-Channels in a 2' x 2' (61 x 61 cm) suspended ceiling installation for the SL-150.

SMA™-600

- Single Column Mounting Plate
Used for the SL-236 installation and attaches to any 1-1/2" NPT extension column. The mounting plate allows 3" (56 mm) fore/aft and 3" (56 mm) left/right adjustments, as well as slight roll, pitch and yaw adjustments.

SMA™-620

- Suspended Column Ceiling Plate
Provides a secure means of attaching the suspended ceiling T-channel in place and allowing the suspended ceiling track to be attached to the sides of the lift. Kit includes eight clips.

SMA™-650

- Threaded Rod Adapter

SS™-10

- Pressure-Sensitive Safety Strip (order with ST-15™ Terminals)

UPB™-1

- Upright Projector Bracket
Allows projectors to hang in an upright position and retain the pitch and roll adjustments of the SL-150 and SL-236. The UPB-1 will accommodate projectors up to 9-1/8" H (232 mm) x 17-1/4" W (438 mm) x 20" D (508 mm).

NOTES:



SECTION 6 TV SOLUTIONS



Chief's CTV™ Series TV Mounting System provides attractive styling and exceptional strength. It is perfectly suited for supporting professional monitors and consumer televisions. The CTV System uses innovative technology with multiple adjustment options, a quick connect/disconnect feature and cable management. Complete with a full line of accessories, the CTV line is sure to answer all your TV and monitor mounting needs.

HOW TO CHOOSE A TV MOUNT

Choosing the right TV mount for your application is simple. Chief TV mounts provide the following benefits:

- Durable, secure designs – compatible with your technology and environment
- Easy to install and adjust – install on the ground and mount
- Great aesthetics and space savings
- Service excellence for all your installation needs

TV MOUNTS

CTV™ - 2527
TV Mount

PG 95



MAX WEIGHT: 150 lbs **B**

CTV™ - 3036
TV Mount

PG 95



MAX WEIGHT: 300 lbs **B**

TV

CUSTOM SOLUTION

CTV™ MOUNTS

Professional TV/Monitor mounts with the industry's first self-leveling quick connect/disconnect feature and built-in cable management.

HE



■ **Built-In Cable Management**
For a clean installation.

■ **Multiple Adjustment Points**
For proper alignment with the center of gravity.

■ **Adjustable Center Point for Easy Tilt.**

■ **Easy Installation and Adjustment!**
Can be entirely assembled on the ground and then mounted.

■ **Dual upper clamp system prevents display from sliding.**

■ **Quick connect/disconnect for a safe and fast installation.**

■ **Heavy-Duty Construction.**

■ **Accommodates 25"–27" or 30"–36" displays.**

■ **Mounts to the wall, finished ceilings or suspended ceilings.**

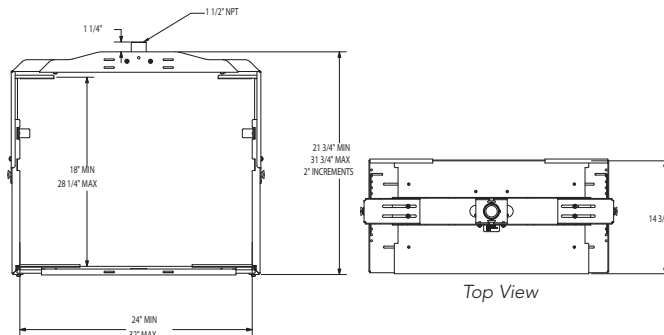

RECOMMENDED ACCESSORIES

PAGE

CMA-110 8" (203 mm) Ceiling Plate	96
CMA-372 Offset Unistrut Adapter	96
CMA-390 16" (40.6 cm) On-Center Ceiling Plate	96
CMA-455 2' x 2' (0.6 x 0.6 m) Suspended Ceiling Tile Replacement Kit	97
CTA-025 25" (63.5 cm) Single Stud Wall Mount Arm	97
CTA-2536 Interior Wall Mounting Support Bracket	97
CTA-100 VCR/DVD Set-Top Box Mounting Accessory	97
CTA-111 Dual Stud Wall Support Bracket	97
CTA-225 25" (63.5 cm) Single Stud Wall Mount Arm with Dual Stud Wall Support Bracket Accessory	97

SPECIFICATIONS

Model:	CTV-2527	CTV-3036
Screen Size	25"–27"	30"–36"
Width	24"–32"	28"–36"
Adjustment	(61–81 cm)	(71–91 cm)
Height	18"–28-1/4"	21-3/4"–34"
Adjustment	(45.7–71.8 cm)	(55.2–86.4 cm)
Tray Depth (Fixed)	14-3/4" (37.5 cm)	14-3/4" (37.5 cm)
Tilt	30°	30°
Color	Black	Black
Weight Capacity	150 lbs (68 kg)	300 lbs (136 kg)

Note: Both models include a 3" (76 mm) pipe.

FAQ

1. **How do I determine the TV/Monitor screen size?**
A The screen size is the diagonal measurement from corner to corner of the screen. You must verify that the actual dimensions of your TV will fit the mount.

HOW TO ORDER

1. Determine the outside height and width of your monitor. Choose the CTV mount that best fits your screen size.
2. Decide how you want to mount the TV and choose the appropriate accessories.
3. Fax or e-mail your order to Customer Service at 1.877.894.6918 (domestic), 952.894.6918 (international) or orders@chiefmfg.com.



TV MOUNT ACCESSORIES

CEILING PLATES

CMA™-100 8" (203 mm) CEILING PLATE WITH ATTACHED ADJUSTABLE NPT COLUMN

- Universal solution for most structural ceiling installations
- Easy way to achieve the correct drop distance 24-1/4"-46" (61.6-116.8 cm)
- Adjustable in 3/4" (19 mm) increments
- Unmatched rigidity with included set screws
- Weight Capacity: 500 lbs (227 kg)
- Also available for 2" NPT column, order CMA-260



CMA™-101 5" (127 mm) DESIGNER CEILING PLATE WITH 1-1/2" NPT OPENING

- Mount using all four holes or two opposing holes
- 4" x 4" (102 x 102 mm) mounting pattern is designed to allow use of 3/8" (10 mm) mounting bolts
- Includes set screw
- Weight Capacity: 500 lbs (227 kg)



CMA™-330 OFFSET CEILING PLATE

- Routes cables through the extension column and out the top of the ceiling plate
- Includes an 8" (203 mm) square ceiling plate with a 1-3/4" (45 mm) high offset
- Overall Height: 4-1/16" (103 mm)
- Attaches to a 1-1/2" NPT column
- Weight Capacity: 500 lbs (227 kg)



CMA™-390 16" (406 mm) / CMA-391 24" (61 cm) ON-CENTER CEILING PLATES

- Attach to finished ceilings using the included lag bolts:
 - 16" (406 mm) on-center joists use the CMA-390
 - 24" (61 cm) on center joists use the CMA-391
- Use on structural ceilings with concrete anchors (CMA-380)
- Attaches to 1-1/2" NPT extension column
- Weight Capacity: 300 lbs (136.4 kg)

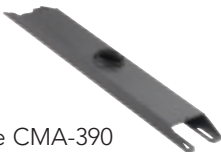

STRUCTURAL ADAPTERS

CMA™-300 PIPE CLAMP

- Clamps onto a 1-7/8"-3-1/2" (48-89 mm) horizontal pipe
- Allows cable access
- Attaches to 1-1/2" NPT threaded extension column
- Weight Capacity: 300 lbs (136.4 kg)



CMA™-365 TRUSS CEILING ADAPTER

- Adapts a 1-1/2" threaded extension column to square, round or rectangular I-beam truss up to 3" (76 mm) in diameter
- Weight Capacity: 250 lbs (113.6 kg)



CMA™-366 ARCHITECTURAL SPANNING ADAPTER

- Spans truss systems 5"-18" (127-457 mm) for easy overhead installation in buildings or exhibits
- Accommodates truss using up to 2" (51 mm) OD round or 1-7/8" (48 mm) square pipe
- Attaches to 1-1/2" NPT extension columns
- Cable management through column
- Weight Capacity: 250 lbs (113.3 kg)



CMA™-372 OFFSET UNISTRUT® ADAPTER

- Quickly installs to all styles of 1-5/8" (41.3 mm) Unistrut®/U-Channel
- Cable management through pole and directly out of Unistrut® adapter
- Attaches to 1-1/2" NPT threaded extension column
- Ships with spring nuts and bolts for attaching to Unistrut®/U-Channel
- Weight Capacity: 500 lbs (227 kg)



MOUNTING BRACKETS

CTA™-100 VCR/DVD SET-TOP BOX MOUNTING ACCESSORY

- Attach a DVD, VCR or set-top box just below the TV mount
- Stack multiple CTA-100 mounting accessories on top of each other
- Weight Capacity: 50 lbs (22.7 kg)



Note: Be sure the weight does not exceed the capacity of the mount.

CTA™-111 DUAL STUD WALL SUPPORT BRACKET

- Use as an addition to the CTA-025 for additional weight support
- Weight Capacity: 300 lbs (136 kg)



CTA™-2536 INTERIOR WALL MOUNTING SUPPORT BRACKET

- Attaches to the studs on the interior of the wall before sheet rock has been installed
- Offers additional support for the CTV
- Weight Capacity: 150 lbs (68 kg)

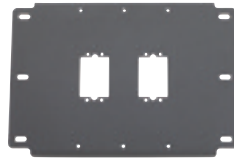

SUSPENDED CEILING KIT

CMA™-455 SUSPENDED CEILING REPLACEMENT KIT

- Quick installation without cutting any ceiling tiles
- Designed to replace a 2' x 2' (0.6 x 0.6 m) ceiling tile or sit above the suspended ceiling
- Secured with four tie wires
- Threaded hole accepts a 1-1/2" (32 mm) NPT extension column
- Includes 10' (3 m) safety cable, 20' (6.1 m) strand wire, two outlet knockouts, four turnbuckles, wood eye bolts and concrete anchors
- Weight Capacity: 250 lbs (113.6 kg)



For more information on the following accessories, visit www.chiefmfg.com.

CTA™-025

- 25" (63.5 cm) Single Stud Wall Mount Arm
- Weight Capacity: 150 lbs (68 kg)

CTA™-225

- 25" (63.5 cm) Single Stud Wall Mount Arm with Dual Stud Wall Support Bracket Accessory
- Weight Capacity: 300 lbs (136 kg)

NOTES

NOTES:

PRODUCT INDEX

2005 PRODUCT GUIDE

A

ADJUSTA-SET Slide Stacker, 18
ASP-401 Individual Control System, 92

C

CMA Adjustable Extension Column, 24, 52, 82, 92
CMA Fixed Extension Column, 24, 52, 66, 82, 92
CMA-100 8" Ceiling Plate with Attached Adjustable 1-1/2" NPT, 22, 53, 66, 82, 96
CMA-101 5" Designer Ceiling Plate, 22, 66, 82, 96
CMA-105 4" Ceiling Plate with 1-1/2" NPT Opening, 22, 66, 82
CMA-110 8" Ceiling Plate with 1-1/2" NPT Opening, 22, 53, 66, 82
CMA-115 6" Ceiling Plate with 1-1/2" NPT Opening, 22, 53, 66, 82
CMA-151 1-1/2" to 1" Adapter/Reducer, 26, 82
CMA-152 1-1/2" to 1-1/2" NPT Coupler, 26, 54, 67
CMA-160 Installation Job Box, 26, 54, 61
CMA-165 Internal Joist Ceiling Kit, 23, 66
CMA-240 Suspended Ceiling Finishing Kit, 92
CMA-250 Flush Mount Adapter, 24
CMA-251 2" to 1-1/2" Adapter/Reducer, 26, 54
CMA-270 Threaded Pipe Coupler, 26, 54
CMA-273 End Cap, 26
CMA-274 Quick-Snap Cable Cover, 24
CMA-275 Quick-Snap Cable Cover, 24, 54, 83
CMA-300 Pipe Clamp, 25, 51, 96
CMA-330 Offset Ceiling Plate, 22, 53, 82, 96
CMA-340 Support Bracket and Cable Assembly, 26, 54
CMA-345 Structural Ceiling Plate with Flex Joints, 22, 53
CMA-347 Vibration Isolator, 26
CMA-351 Heavy-Duty Swivel Adapter with Stops, 26, 54, 67
CMA-360 I-Beam Clamp, 25, 51
CMA-362 C-Clamp, 25, 51
CMA-365 Truss Ceiling Adapter, 25, 51, 96
CMA-366 Architectural Spanning Adapter, 25, 51, 96
CMA-372 Offset Unistrut Adapter, 25, 51, 96
CMA-380 Concrete Fastener Kit, 25
CMA-385 Internal Joist Mount, 25, 51
CMA-390 16" On-Center Ceiling Plate, 25, 51, 67, 96
CMA-391 24" On-Center Ceiling Plate, 25, 51, 96
CMA-395 100 Degree Angled Ceiling Plate with Threaded Coupler, 22
CMA-440 Lightweight Suspended Ceiling Kit, 23, 83
CMA-450 Suspended Ceiling Kit, 23, 83
CMA-455 Suspended Ceiling Replacement Kit, 23, 83, 97
CMA-640 Finishing Ring, 26, 54
CMA-641/642 Finishing Ring, 26
CMA-700 Easy Installation Kit, 22, 67
CTA-025 25" Single Stud Wall Mount Arm, 97
CTA-100 VCR/DVD/Set-Top Box Mounting Accessory, 97
CTA-111 Dual Stud Wall Support Bracket, 97
CTA-225 25" Single Stud Wall Mount Arm with Dual Stud Wall Support Bracket, 97
CTA-2536 Interior Wall Mounting Support Bracket, 97
CTV TV/Monitor Mount, 95

E

ENS Lateral Shift Extrusion, 53

F

FCB Height-Adjustable Triple Arm Desk Mount, 77
FCD Dual Arm Desk Mount, 76
FCG Height-Adjustable Dual Arm Desk Mount, 77
FCS Single Arm Desk Mount, 76
FCV Height-Adjustable Single Arm Desk Mount, 77
FDP Dual Display Pole Mount, 73
FHP Ceiling Mount with Adjustable Column, 79
FMA-220 Dual Array, 80
FMA-320 Triple Array, 80
FPD Dual Arm Pivot/Tilt Pole Mount, 78

FPM Tilt Wall Mount, 72
FPP Pivot/Tilt Pole Mount, 78
FPS Single Arm Pivot/Tilt Pole Mount, 78
FSA-1000 Q2 Mounting System Lockable Latch, 83
FSA-1001 Wall Plate Adapter, 83
FSA-1002 Desk Mount Adapter, 83
FSA-1003 Extension Arm, 83
FSA-1004 Extension Height-Adjustable Arm, 83
FSA-1005 Arm Security Hardware Kit, 83
FSA-1007 Centris Quick Release Interface, 83
FSA-1009 Height-Adjustable Arm Security Hardware Kit, 83
FSM Fixed Wall Mount, 72
FSP Single Display Pole Mount, 73
FWB Height-Adjustable Triple Arm Wall Mount, 75
FWD Dual Arm Wall Mount, 74
FWG Height-Adjustable Dual Arm Wall Mount, 75
FWP Pivot/Tilt Wall Mount, 74
FWS Single Arm Wall Mount, 74
FWV Height-Adjustable Single Arm Wall Mount, 75

G

GW-200 Lens Accessory, 24

H

HC-1 Heavy-Duty Cable System, 27
HD-120 Ektagraphic III Hold Down Kit, 24
HD-150 Ektapro Hold Down Kit, 24

I

IR-10 Infrared Remote Control, 92

J

JWD Dual Arm Wall Mount, 63
JWP Pivot/Tilt Wall Mount, 63
JWS Single Arm Wall Mount, 63

L

LC-1 Cable Lock, 27
LCD Projector Stacker, 17
LCDA Non-Inverted Universal Projector Mount, 15
LPK-1 Low-Profile Mounting Kit, 24
LS-135 Lens Support Bracket, 24
LSB-100 Lateral Shift Accessory, 24

M

MAC-160 Medium Flat Panel Display Accessory, 54
MCD Dual Ceiling Mount, 64
MCS Single Ceiling Mount, 64
MICRO-SET Slide Stacker, 18
MSR Fixed Wall Mount, 60
MTR Tilt Wall Mount, 61
MWH Single Arm Wall Mount, 62
MWR Single Arm Wall Mount, 62

P

P-45 45" Chrome Post, 54
PAC-100 Accessory Shelf, 54
PAC-105 Extreme Stabilizer Kit, 54
PAC-110 Aesthetic Cover Kit, 54
PAC-115 Steel Stud/Drywall Anchor Kit, 52, 67
PAC-125 Lateral Shift, 53, 67
PAC-126 Lateral Shift, 53
PAC-130 Q-Latch Mounting System Lockable Latch, 52
PAC-135 Q-Latch Mounting System Lockable Latch with Padlock, 52
PAC-140 Q-Clamps, 52
PAC-141 Back-to-Back Display Head Assembly, 54
PAC-142 Single Display Head Assembly, 54
PAC-143 Back-to-Back Small Flat Panel Head Assembly, 54
PAC-150 Video Conferencing Shelf, 54
PAC-160 Small Flat Panel Accessory Bracket, 54
PAC-251 CPU/DVD/VCR Universal Adapter, 50
PAC-252 CPU Universal Adapter, 50
PAC-300 Side Speaker Adapter, 50
PAC-301 Center Channel Speaker Adapter, 50

PAC-302 Center Channel Speaker Shelf, 50
PAC-390 Cube System Adapter, 50
PAC-400 90 Degree Rotation Adapter, 50
PAC-Y1 Yamaha YSP-1 Center Channel Speaker Adapter, 50
PAS-1 18" x 24" Accessory Shelf, 54
PAS-100 Smoked Acrylic Accessory Shelf, 54
PCL Electric Ceiling Lift, 91
PCM Single Ceiling Mount, 40
PDC Dual Ceiling Mount, 41
PDR Dual Arm Wall Mount, 38
PFB Dual Pole Floor Stand, 46
PFS Floor Stand, 45
PG-1A Projector Guard, 21, 27
PG-2A Projector Guard, 21, 27
PL-1 Projector Lock, 20, 27
PL-4 Projector Lock, 27
PLP Pull-N-Tilt Wall Mount, 35
PNR Dual Arm Wall Mount, 37
PPC Conferencing and Presenters Cart, 48
PPD Conferencing and Presenters Cart, 48
PPH Heavy-Duty Tilt Wall Mount, 34
PRO Lockable Tilt Wall Mount, 34
PSH Heavy-Duty Fixed Wall Mount, 33
PSM Fixed Wall Mount, 32
PSMH, 32
PSS Table Stand, 44
PST Portrait/Landscape Fixed Wall Mount, 33
PTC Mobile Cart, 47
PTCLF Leveling Feet, 54
PTS Table Stand, 44
PUL Pop-Up Lift, 90
PWR Single Arm Wall Mount, 36

Q

QD-1 Quick Disconnect, 26

R

RC-10 Radio Frequency Remote Control, 92
RPA Inverted Custom Projector Mount, 10
RPA-U Inverted Universal Projector Mount, 12

S

SA-1 Security Anchor, 27
SL-150 Smart-Lift, 88
SL-236 Smart-Lift, 89
SMA-600 Single Column Mounting Plate, 92
SMA-620 Suspended Column Mounting Plate, 92
SMA-650 Threaded Rod Adapter, 92
SS-10 Pressure-Sensitive Safety Strip, 92
SSC Security Screw Cover Kit, 27, 52, 83

T

TPA-100 Finishing Cover, 54
TPA-110 Small Flat Panel Tilt Adjustable Pole Mount, 54
TPA-111 Small Flat Panel Tilt Adjustable Truss Mount, 54
TPA-112 Small Flat Panel Fixed Pole/Truss Mount, 54
TPM Tilt-Adjustable Pole Mount, 43
TPP Tilt-Adjustable Truss Mount, 43
TPS Fixed Truss and Pole Mount, 42

U

UMA-1051 1" Coupler, 83
UPB-1 Upright Projector Bracket, 92
UPC Non-Inverted Projector Mount, 14
USA-1 13" x 13" Accessory Shelf, 54

V

VCM Inverted Heavy-Duty Projector Mount, 16

W

WMA-300 Wall Mount Arm, 25

X

XY-1 Heavy-Duty Lateral Shift Bracket, 26

TERMS AND CONDITIONS

CHIEF MANUFACTURING INC.

PRICES: Prices are subject to change without notice. Orders are priced at the pricing in effect on the date your purchase order was received. To guarantee pricing for a specific period, customer must obtain a written quotation from Chief Manufacturing. Chief Manufacturing only sells directly to authorized Chief dealers and distributors. Possession of said price book does not constitute an offer to sell.

QUANTITY DISCOUNTS: With the exception of CMA accessories, products with the same 3-letter prefix may be combined to receive quantity-based discounts. For example: three RPA1200 can be mixed with three RPA800 for the 6-11 piece quantity price break. However, three RPA1200 cannot be mixed with three PSM2042. Contact Chief if you have any questions regarding price structure.

TERMS AND CONDITIONS: All accounts are due and payable in U.S. funds according to the terms of the invoice. Payments by credit card (Visa, MasterCard, American Express and Discover) are accepted without an additional processing charge. All credit card orders are pre-authorized at the date of the purchase order; however, except in the case of custom orders, payment is not charged until the order ships. C.O.D. and prepaid orders are accepted when paid with a company check. Wire transfer information is also available upon request. Contact Chief for details on your account, including terms of sale and price structure.

ORDERING: Because of the specific nature of our products and our commitment to entering and shipping orders accurately, we prefer that orders be placed in writing via a purchase order and sent to us via fax (877-894-6918) or via e-mail (orders@chiefmfg.com). In urgent situations, we will make every effort to take accurate orders verbally when requested by the customer. Chief cannot guarantee that verbal miscommunication errors will result in the purchaser's favor.

ORDER CONFIRMATION: Customers will receive a written confirmation of their order within 1-3 hours of receipt of purchase order. Unless requested otherwise, the confirmation will be received via the same method we received your purchase order. If you do not receive a confirmation of your order, please contact us as it is possible we did not receive your original order. Please review the confirmation to ensure Chief has recorded the details of the transaction as you expected and notify Chief of any discrepancies immediately.

CHANGES TO ORDERS: Because expedited orders begin the production and shipping fulfillment process immediately upon receipt and entry of purchase order, it is frequently not possible to change these orders. Other orders will be changed as possible. Contact Customer Service at 800.582.6480 (domestic) / 952.894.6280 (international) and they will work through an alternative solution with you. In all cases, the customer is responsible for incremental charges incurred because of the change.

SPECIAL ORDERS: Some of Chief's products can be customized to fit your specific applications. Contact Inside Sales for additional information and pricing. Orders for large quantities of products may also be considered a special order. Any special order or custom product not normally carried in inventory cannot be returned. All electrical products and products with quote pricing are treated as special order items.

PRODUCT CHANGES/DISCONTINUED PRODUCTS: Chief is constantly developing new products and making improvements to existing ones; therefore, we reserve the right to revise or change specifications, designs and model numbers and to discontinue models without notice.

PACKAGING: Where possible and practical, Chief will bulk-pack orders with three or more items shipping expedited freight or with five or more items shipping ground freight. If you would like an order not meeting the above criteria bulk packed please request this service on your purchase order. We are not responsible for air-freight, C.O.D. or other charges due to multiple single package shipments. Please note that the size and weight of many of our products prevent us from being able to bulk pack all items.

DELIVERY: All promises of delivery are made in good faith and every reasonable effort is made to see that delivery schedules are met. However, if Chief is unable to meet a schedule due to factors beyond our control such as, but not limited to, failure of our suppliers to meet their promised dates or weather-related delivery delays, Chief will not be responsible for significant or specific damage. Significant or specific damages may be, but are not limited to, express shipping method charges or installation delay charges. Contact the Chief Inside Sales team for assistance with freight estimates specific to your needs. Delivered prices do not include any type of extraordinary charges such as lift gate requirements, inside delivery charges, residential charges or any other non-standard charges which apply.

FREIGHT AND FREIGHT DAMAGE: Because all Chief product ships FOB Savage, MN or point of shipment, all shipping costs and risks of freight damage are the responsibility of the purchaser. It is the customer's responsibility to immediately open and inspect all packages and, in the event there is any damage or shortages, file a claim with the freight company. Please contact Chief Customer Service at 800.582.6480 (domestic) / 952.894.6280 (international) to get contact information about the specific freight company used and to discuss receiving a replacement product. Keep the damaged product in its original packaging and carton. Unless concealed damage is reported to the Carrier and Chief immediately, there is no recourse. The customer will be charged for any replacement product as the eventual credit will come directly from the carrier via the claim filed.

RETURNS AUTHORIZATION: All merchandise returned to Chief must be returned with prior authorization and a Return Authorization number provided by Customer Service. Defective or product received incorrectly due to an error on Chief's part will be credited to your account in full. In situations where the dealer needs to return merchandise due to a change in its project/equipment or due to ordering incorrectly, a restock charge will apply as follows. Merchandise invoiced in the past 0-30 days - 20%; 31-60 days - 25%; 61-90 days - 40%. Reduced fees may be given for an accompanying reorder of equal or greater value. Returns are not allowed for merchandise over 90 days old; electrical lift products; special order products, or discontinued merchandise. Products returned that are damaged or missing parts will not be eligible for credit unless they can easily be made saleable. Additional charges for parts and labor may apply.

LIMITED WARRANTY: With the exception of electric, gas cylinder and one-way bearing mechanisms, Chief warrants its products to be free of defects in material and workmanship for 10 years. All warranties are in effect beginning the date the product was invoiced by Chief. Electrical mechanisms (such as lift products) have a 1-year limited warranty. Gas cylinder and one-way bearing mechanisms have a 5-year limited warranty. All warranties are in effect for the original purchaser only. Chief disclaims liability for any modifications, improper installation and/or installations over the specified weight capacity. Chief also disclaims liability for any modifications made to electrical mechanisms, improper installation, incorrect voltage connection and/or installations over the stated weight capacity. All Electrical Mechanisms are intended for indoor use only and failure to comply will void warranty. Chief's sole warranty obligation to the owner of its products is to repair or replace (at Chief's discretion) defective products at no charge to the original purchaser within the warranty period. The purchaser is responsible for returning the product to Chief Manufacturing via prepaid shipping. To the maximum extent permitted by applicable law, Chief disclaims any other warranties, express or implied, including warranties of fitness for a particular purpose and warranties of merchantability. Chief will not be liable for any damages whatsoever arising out of the use or inability to use Chief products, even if Chief has been advised of the possibility of such damages. Chief bears no responsibility for incidental or consequential damages. This includes, but is not limited to, any labor charges for the repair of Chief products performed by someone other than a Chief employee. Because some states and jurisdictions do not allow the exclusion or limitation of liability for consequential or incidental damages, the above limitation may not apply. Chief will not be responsible for damage to Chief products caused by misuse, abuse, failure to properly package the product for return to Chief or for damage caused by carriers during shipment to or from Chief. Any repairs to Chief products required due to misuse, abuse or shipping damage or repairs of defective Chief product outside the warranty period will be performed at the current rates established by Chief for factory service.

PRO AV | HOME ENTERTAINMENT



CHIEF MANUFACTURING INC.

www.chiefmfg.com ■ P 800.582.6480 ■ 952.894.6280 ■ chief@chiefmfg.com
■ F 877.894.6918 ■ 952.894.6918

USA/INTERNATIONAL ■ 8401 EAGLE CREEK PARKWAY, STE. 700, SAVAGE MN 55378 USA

CSAV EUROPE B.V. ■ ZEKERINGSTRAAT 17, 1014 BM AMSTERDAM, NETHERLANDS
P 31 (0)20 5708923 ■ F 31 (0)20 5708989 ■ europe@chiefmfg.com

©2005 Chief Manufacturing Inc. Printed in the USA. 600015C 9/05. Chief is a registered trademark of Chief Manufacturing Inc.
All other brand names or marks are used for identification purposes and are trademarks of their respective owners.
U.S. Patents 6,905,101; 6,402,109. Other patents pending.