

**Operators & Service
Manual
XL88**

EVI PRO AUDIO GROUP
Klark Teknik Building,
Walter Nash Road, Kidderminster,
Worcestershire DY11 7HJ,
England

Tel: (01562)741515 Fax: (01562)745371

DECLARATION OF CONFORMITY

The Directives Covered by this Declaration

89/336/EEC Electromagnetic Compatibility Directive, amended by 92/31/EEC & 93/68/EEC

Equipment Type	Product Name
----------------	--------------

Matrix Mixer	XL88
--------------	------

The Basis on which Conformity is being Declared

The Products named above comply with the requirements of the above EU directives by meeting the following standards:

EN55013: 1990

EN50082: 1992

Signed:  Alex Cooper

Authority: Project leader

Date: 28th November, 1995

Attention!

The attention of the specifier, purchaser, installer or user is drawn to special limitations of use which must be observed when these products are taken into service to maintain compliance with the above directives. Details of these special measures and limitations to use are available on request and are also contained in product manuals.

ATTENTION!

CABLES

This product should only be used with high quality, screened twisted pair audio cables, terminated with metal bodied 3-pin XLR connectors. The cable shield should be connected to pin 1. Any other cable type or configuration for the audio signals may result in degraded performance due to electromagnetic interference.

ELECTRIC FIELDS

Should this product be used in an electromagnetic field that is amplitude modulated by an audio frequency signal (20Hz to 20KHz, the signal to noise ratio may be degraded. Degradation of up to 60dB at a frequency corresponding to the modulation signal may be experienced under extreme conditions (3V/m, 90% modulation).

No permanent damage or degradation of performance will be caused by these conditions.

CONTENTS

INTRODUCTION	8
INSTRUMENT FAMILIARISATION	9
USING THE MIDAS XL88	12
APPLICATIONS	16
AUDIO CONNECTIONS	19
SPECIFICATIONS	20
CIRCUIT DESCRIPTIONS	22
CHANNEL MODULE	23
PFL MIX & OUTPUT MODULE	26
POWER SUPPLY	28
WARRANTY	31
SERVICE REQUEST FORM	32
SCHEMATIC DIAGRAMS	
CHANNEL IN/OUT	
CHANNEL MIX LEVEL	
PFL MIX & OUTPUT	
CHANNEL IN/OUT METER SECTION	
BLOCK DIAGRAM	
POWER SUPPLY	

THANK YOU FOR USING THIS MIDAS PRODUCT

To obtain maximum performance from this precision electronic product, please study these instructions carefully. Installation and operation of the XL88 are not complicated but the flexibility provided by its operating features merits familiarisation with its controls and connections. This unit has been prepared to comply with the power supply requirements that exist in your location.

Precautions

Do not install this unit in a location subjected to excessive heat, dust or mechanical vibration. Before connecting the unit to the mains power, ensure that the operating voltage is correct for your local supply. It is important that you observe the following instructions if another voltage setting is required:

Voltage Selection and Power Connection

Connection is made by means of an IEC standard power socket. The rear panel voltage label indicates the voltage required for satisfactory operation of the unit. Before connecting this unit to the mains supply, ensure that the fuse fitted is the correct type and rating as indicated on the rear panel adjacent to the fuse holder. To change the mains voltage please refer to the 'Voltage Changeover' section on page 24.

* Mains voltage adjustment should be carried out by a qualified service technician only.

Safety Warning

This unit is fitted with a 3-pin power socket: For safety reasons the earth lead should not be disconnected. If you encounter a problem with earth loops, the ground-lift link located inside the unit should be removed to isolate the signal earth from the chassis earth (see page 23). Grounding problems should not normally be encountered with the XL88. All pin 1's are commoned but not connected directly to earth. Should any problems be encountered they will be caused by the commoning of the grounds of the other equipment connected to the XL88.

To prevent shock or fire hazard, do not expose the unit to rain or moisture.

To avoid electrical shock, do not remove covers. Refer servicing to qualified personnel only.

After you have unpacked the unit

Save all the packing materials - they will prove valuable should it become necessary to transport the unit.

Please inspect this unit carefully for any sign of damage incurred during transportation. It has undergone stringent quality control inspection and tests prior to packing and left the factory in perfect condition.

If, however, the unit shows any signs of damage, notify the transportation company without delay. Only you, the consignee, may institute a claim against the carrier for damage during transportation.

If necessary, contact your supplier or, as a last resort, your Midas importing agent* who will fully cooperate under such circumstances.

* See enclosed world-wide importing agents list.

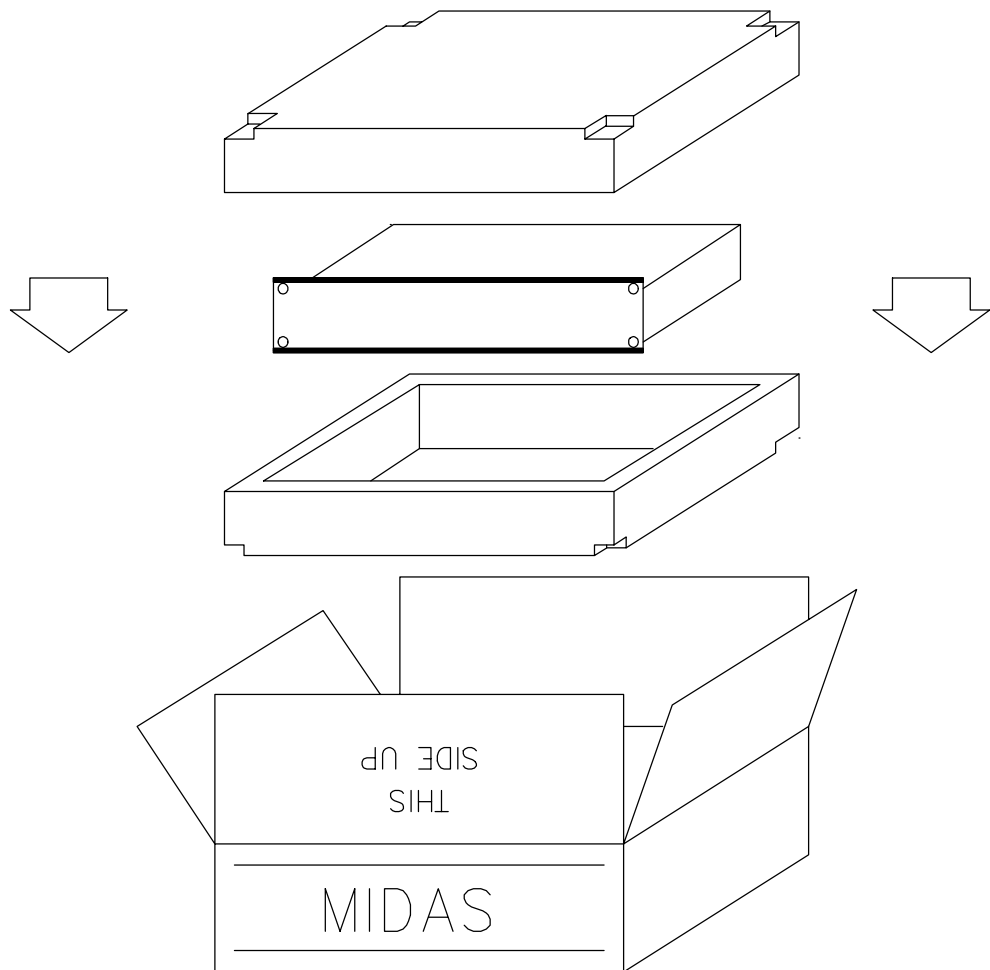

Introduction

The Midas XL88 is a line level 8 x 8 matrix mixer which will greatly expand the capabilities of any mixing console to give eight fully independent sound balances from eight pre-mixed group outputs from the main console. A few specialised consoles have a matrix incorporated into their design, but the XL88 can offer this valuable extra facility to any sound installation, and is suitable for use with loudspeaker arrays, satellite links, land lines, and audio applications of all kinds.

The construction of the XL88 is fully modular to Midas' high standard. The steel frame is designed to be mounted in a standard nineteen inch rack and is four units (4U) in height. Rear support is not required. Inputs and outputs are all balanced, either electronically or via optional transformers. The audio quality is, of course, to a fully professional standard and the unit interfaces easily with other equipment.

The XL88 frame contains eight identical channel modules, each of which has the following features:

Balanced input

Direct output with level control and mute button

Eight matrix routing switches and level controls

matrix output with level control via a large Penny and Giles fader

Matrix output mute button

20 segment LED bargraph meter switchable to show the level of the direct output or the matrix output

A Pre-Fade Listen function allows instant access to all inputs and matrix outputs. A rear panel XLR carries the PFL signal to the main mixing console or to any other monitoring system.

The Midas XL88 has been designed for ease of use with clear panel markings and LED status indicators for all audio switches. Multiple XL88 units may easily be combined to extend the matrix facility to 8 x 16, 8 x 24, or in fact to virtually any number of outputs.

Reliability Control

Even with the advanced technology incorporated in this product, each instrument is given the full backing of Midas' Reliability Control which proves it against a specification consistent with the highest professional standards. Only top quality components are used and every unit is bench tested and aligned before a burn-in period and final performance test.

Instrument Familiarisation

Front panel functions

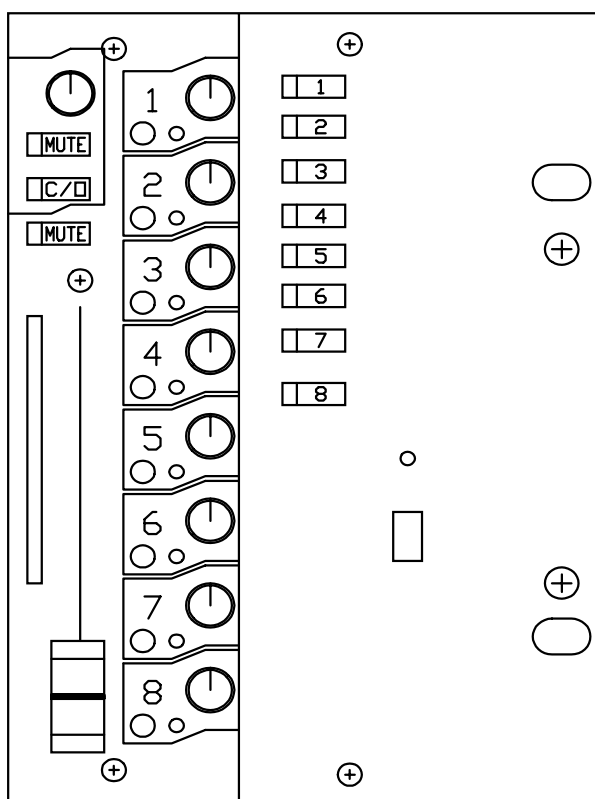

Each of the eight channels of the Midas XL88 has the following features:

- 1) **Direct Output Level Control.** Regardless of the settings of any of the other controls on the unit, apart from the Direct Output Mute, this sets the gain of the Direct Output of the channel from minus infinity up to +10dB. The unity gain position (0dB) is marked.
- 2) **Direct Output Mute.** This cuts the Direct Output of the channel. A red LED indicates when Direct Output Mute is in operation.
- 3) **Meter Changeover (C/O).** The 20-segment LED bargraph meter can measure the level of either the Direct Output or the Matrix Output from the module. When the Meter Changeover button is pressed and the yellow LED glows, the meter reads the level of the Matrix Output. The secondary function of the Meter Changeover button is to decide whether the pre-fade listen facility picks up the Direct Output or the Matrix Output from the module. Whichever signal is

being measured by the meter is also available for pre-fade listen.

4) **Matrix Output Mute.** This cuts the Matrix Output from the module. A red LED indicates when Matrix Output Mute is in operation.

5) **Matrix Output Fader.** The Penny and Giles fader controls the level of the Matrix Output from the module.

6) **Routing buttons.** The eight Routing buttons send the input of the module to any or all of the eight Matrix Outputs. Routing is active when the button is depressed and the yellow LED is glowing.

7) **Routing Level Control.** Each of the eight Routing Level Controls governs the amount of signal from the module sent to the respective Matrix Output, from minus infinity dB to +10dB. Note that these controls affect the signal sent FROM the module to the Matrix Outputs, not signals coming into the module.

8) **Output PFL buttons.** Any input or output to or from the XL88 can be selected for Pre-Fade Listen. With the Meter Changeover button of any module unselected, the PFL button will access the INPUT to that module, before the Direct Output level control. With the Meter Changeover button selected, and the LED glowing, PFL will access the Matrix Output from the module.

Rear panel functions

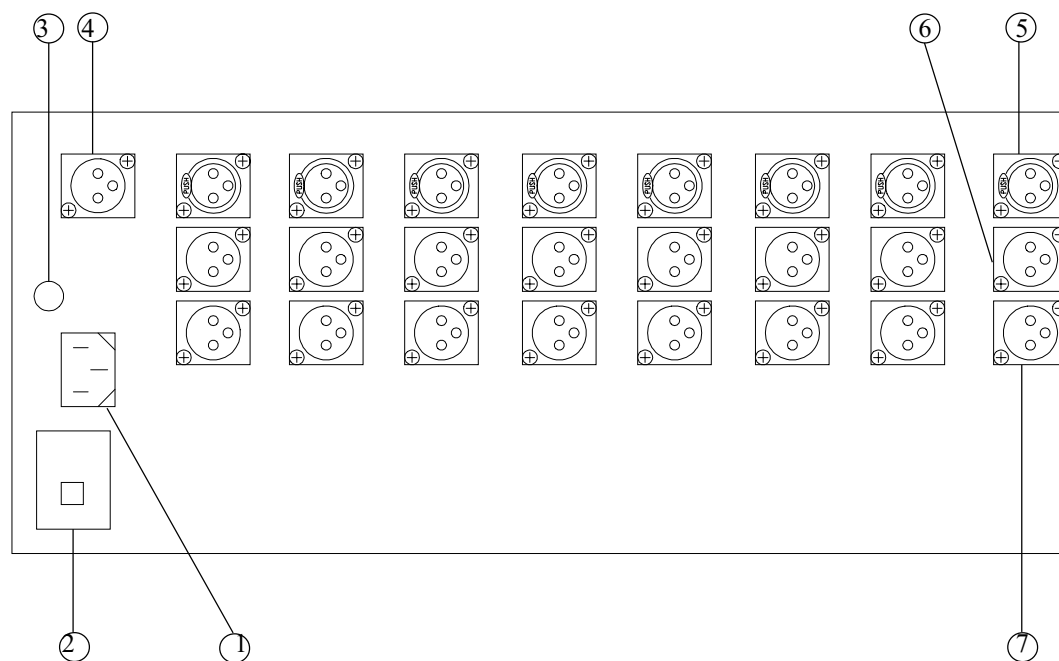

1) **Mains.** Supplied via an IEC standard 3-pin connector. A compatible power cord is supplied with the unit.

2) **Voltage Changeover Switch.** The unit can be set for 220v or 110v operation. The switch is recessed behind a panel which indicates the voltage selected. Removal of this panel allows the switch position to be changed. The panel must then be turned around before it can be replaced and it will indicate the required mains voltage.

3) **Mains Fuse.** Always replace with the correct type and rating of fuse, as indicated adjacent to the fuseholder.

Audio connections are made via balanced XLRs. For wiring details please see the 'Audio Connections' section of this manual on page 15.

4) **Pre-Fade Listen output (PFL).**

5) **Inputs.**

6) **Direct Outputs.**

7) **Matrix Outputs.**

Using the Midas XL88

Signal Paths

There are four types of signal path through the XL88:

- 1) Input to Direct Output
- 2) Input to Matrix Output
- 3) Input to Pre-Fade Listen
- 4) Matrix Output to Pre-Fade Listen

1) Input to Direct Output. Using Module 1 of the XL88 as an example, the input to the module takes the following signal path:

Input XLR 1
Direct Output Level Control
Direct Output Mute
Direct Output XLR 1

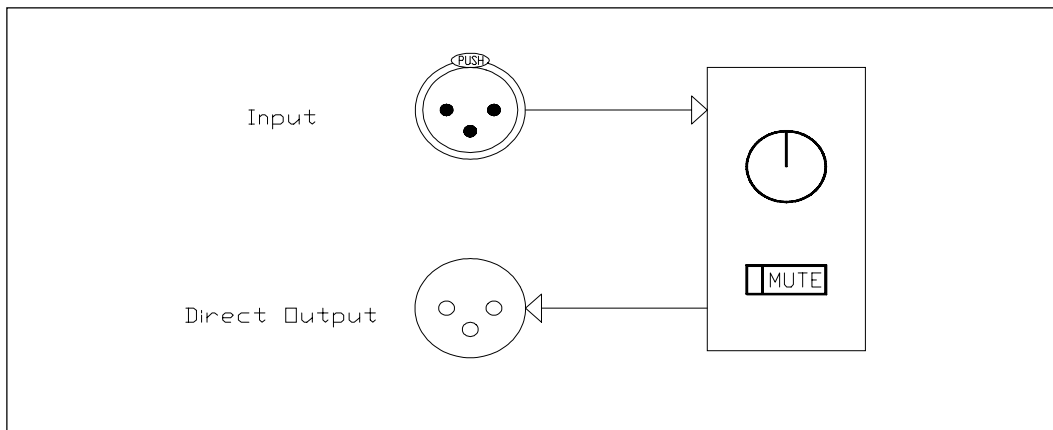

The Direct Output Level Control can vary the level from no signal to +10dB. The Direct Output Mute cuts the signal and is active when the button is depressed and the red LED glowing.

The level of the Direct Output can be measured on the 20 segment LED bargraph meter by leaving the Meter Changeover button out. When this button is out, the input signal to the module is available for Pre-Fade Listen.

2) Input to Matrix Output. Using Module 1 of the XL88 as an example, the input to the module takes the following signal path:

- Input XLR 1
- Routing buttons, Module 1
- Routing Level Controls, Module 1
- Matrix mixing point, any or all modules
- Matrix Output Faders, any or all modules
- Matrix Output Mutes, any or all modules
- Matrix Output XLRs, any or all modules

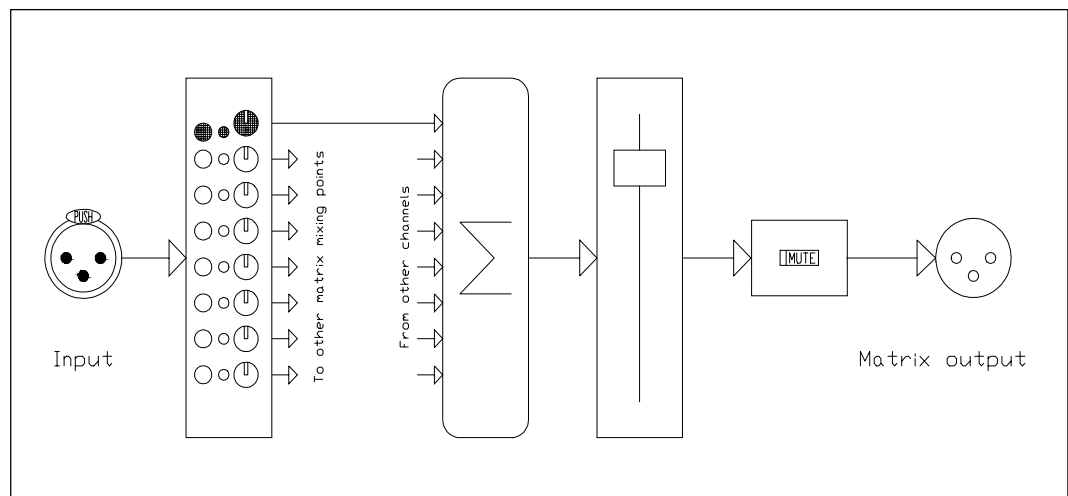

The eight Routing buttons on the input module are used to select which outputs the signal will be routed to. The eight Routing Level Controls adjust how much level is sent to each Matrix mixing point. Please note that these controls adjust the OUTGOING signal from the module.

The Matrix Output Fader on each module controls the level of the mixed signal from the corresponding Matrix Output and the Matrix Output Mute button cuts that output.

The XL88 has an XLR output for Pre-Fade Listen which can be connected to a channel of the main mixing console for monitoring, or to a headphone amplifier or power amplifier and monitor loudspeaker. Please note that none of the Mute buttons affect PFL.

3) Input to Pre-Fade Listen. Using Module 1 of the XL88 as an example, the input to the module takes the following signal path:

- Input XLR 1
- Meter Changeover button, Module 1
- Output PFL button 1
- PFL output XLR

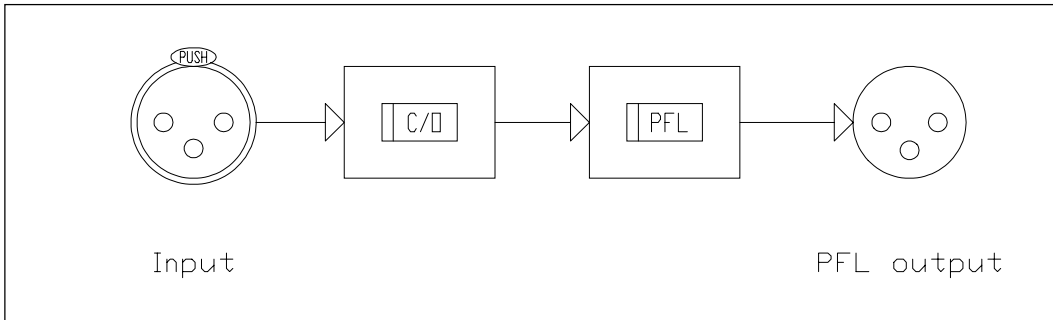

To Pre-Fade Listen to any input, leave the appropriate meter change over switch out and press the corresponding output PFL button whose

Any combination of inputs and outputs may be selected for PFL at the same time except that it is not possible to PFL the input and matrix output of any one module simultaneously.

4) Matrix Output to Pre-Fade Listen. Using as an example Module 1 of the XL88 routed to Matrix Output 8, the signal takes the following path:

- Input XLR 1
- Routing buttons, Module 1
- Routing Level Controls, Module 1
- Matrix mixing point, Module 8
- Meter Changeover button, Module 8
- Output PFL button 8
- PFL Output XLR

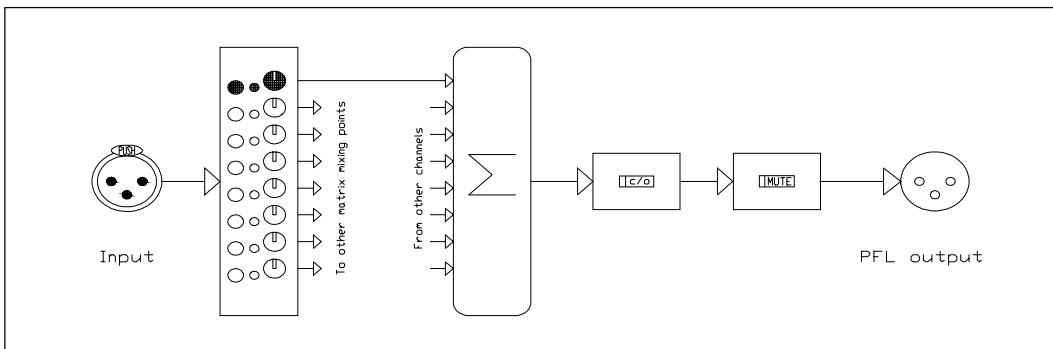

To Pre-Fade Listen any output, leave the Meter Changeover switch on the corresponding module out, the LED will be off, and press the Output PFL button whose associated red LED will light.

Any combination of inputs and outputs may be selected for PFL at the same time except that it is not possible to PFL the input and matrix output of any one module simultaneously.

Using the Direct Outputs

The Direct Outputs are simple to use. The input signal to each module is buffered and amplified, directed through a level control and a muting button, and is presented on an XLR connector directly below the input.

The level of the Direct Output may be measured on the 20 segment bargraph meter by pressing the Meter Changeover button so that the yellow LED illuminates.

It is also possible to Pre-Fade Listen to any input by pressing the Meter Changeover button and the corresponding Output PFL button. The signal will be taken from before the level control and muting switch and directed to the PFL output XLR.

Using the Matrix Outputs

It is important to note that the Routing Level Controls affect the OUTGOING signals from each module, therefore to mix eight signals to Matrix Output 8, for instance, the highlighted controls are used:

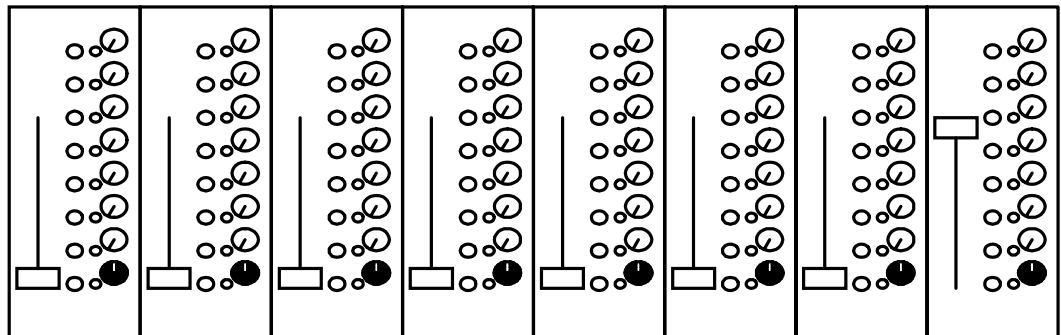

The upper row of Mute buttons mute the eight INPUTS to the XL88. The lower row of Mute buttons mute the eight MATRIX OUTPUTS.

The level of the Matrix Output may be measured on the 20 segment bargraph meter by leaving the Meter Changeover button out so that the LED is off. It is possible to pre-fade listen any Matrix Output by leaving the appropriate

Meter Changeover button out and pressing the corresponding Output PFL button. The signal will be taken from before the fader and muting switch and directed to the PFL output XLR.

Using Pre-Fade Listen

It is possible to pre-fade listen any combination of inputs and matrix outputs at the same time, except that it is not possible to PFL the input and output of any one module simultaneously.

To pre-fade listen any input, press the Meter Changeover button (yellow LED on) and the corresponding Output PFL button (red LED on). The signal will be taken from before the level control and muting switch and directed to the PFL output XLR.

To pre-fade listen any Matrix Output, leave the appropriate Meter Changeover button out (LED off) and press the corresponding Output PFL button (red LED on). The signal will be taken from before the fader and muting switch and directed to the PFL output XLR.

Applications

Standard mixing consoles which do not incorporate a matrix output suffer from one major drawback: a severely limited ability to set up different mixes on different group outputs. Adding a matrix mixer, such as the Midas XL88, to a standard console makes it possible for each of the outputs of the matrix to have a different balance. In the case of the XL88, the eight input channels can be balanced differently in each of the eight matrix outputs. It can therefore be described as an 8 x 8 matrix. But more than that, the XL88 has independent direct outputs from the channels which make it possible by adding further XL88 units to extend the matrix to any number of outputs, each with its own unique balance of the eight input channels.

Applications of the Midas XL88 will be as varied as the people who use sound equipment. Some of the more typical configurations are illustrated here.

Theatre

A large quantity of loudspeakers will be necessary to provide adequate coverage in virtually any theatre, but they don't necessarily all need the same sound balance. Particularly for sound effects and for positioning sounds in the auditorium, a matrix output will be invaluable.

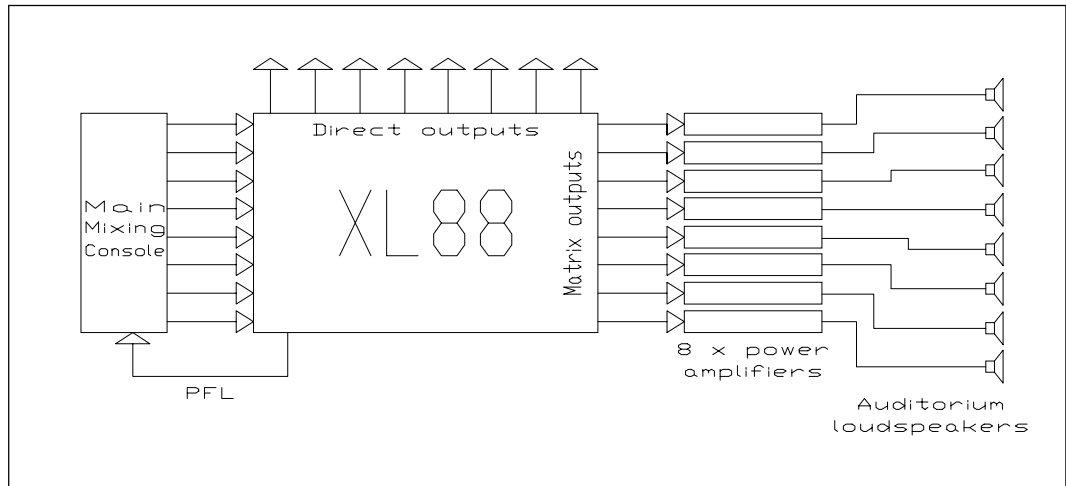

The large output faders give quick, precise, control over the output level to each loudspeaker, or group of loudspeakers. To pre-fade listen any input or output, the XL88's PFL output is brought back to a spare channel on the main console where the operator can monitor it on headphones simply by pressing the appropriate PFL button on the main console.

Public Address

Using the same configuration as the theatre system, the XL88 can conveniently provide independently mixed output signals for main and delayed loudspeakers, and also for additional recording and broadcast units.

Broadcast

In broadcasting, there is a heavy requirement for various types of clean feed and 'mix minus' signals. This illustration shows how it is possible for each of eight individual contributors to a program to hear a mix of signals from the other seven, MINUS their own output:

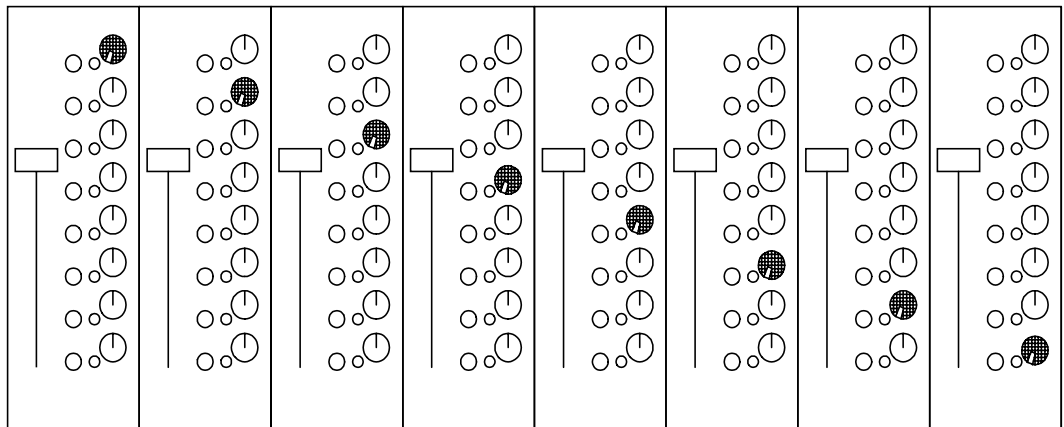

Sophisticated Distribution Amplifier

Another way of looking at the XL88 is as a sophisticated distribution amplifier. At its simplest, the XL88 can be a single-input eight-output distribution amplifier. Yet it can handle any level of complexity of distribution up to eight inputs combined in any proportion into eight individually controllable outputs.

Stacking the XL88

The Direct Outputs of the XL88 can be used to link more XL88 units to create an 8 x 16 matrix with two XL88s, or an 8 x 24 matrix with three. The connection of two XL88 units to a main mixing console to give an 8 x 16 matrix with PFL facilities is as follows:

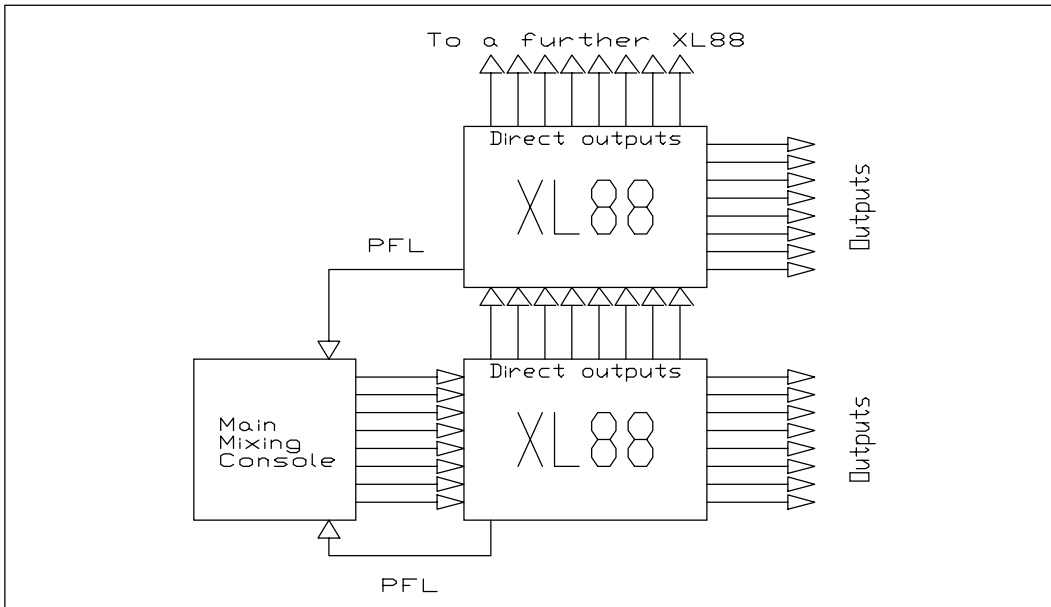

Audio connections

Input

The input circuitry is a transformerless, electronically balanced design which achieves a common mode rejection of at least -50dB from 20Hz to 10kHz.

If transformer balancing of the inputs is required, this must be stated at the time of order as they are not retrofittable.

Output

The output circuitry is a transformerless, electronically balanced design which achieves an input rejection of at least -65dB from 20Hz to 10kHz. The output is capable of driving +21dBm into a 600 ohm load.

If transformer balancing of the outputs is required, this must be stated at the time of order as they are not retrofittable.

Balanced Circuits

Transformer or electronically balanced connections have the benefit of Common Mode Rejection which eliminates externally induced interference such as mains hum etc. Balancing is especially useful when long cable runs are used between pieces of equipment.

Transformer balanced circuits have the added advantage of being 'fully floating' with the ground (earth) or screen being totally isolated from the signal. In installations where a difference in earth potential is likely to occur, this isolation prevents grounding problems which can in some cases damage the equipment.

XLR Pin Connection (Input and Output)

Pin 1 Ground (Earth)

Pin 2 Signal

Pin 3 Signal

Unbalanced

For unbalanced operation, connect Pin 2 to Pin 1 only on the inputs/outputs which are being run unbalanced.

Specification

Inputs

Type	Eight
Impedance (ohm)	Balanced (electronically)
Balanced	20k
Unbalanced	10k

Outputs

Direct	Eight
Matrix	Eight
P.F.L	One
Type	Balanced (electronically)
Min. load impedance	600ohm
Source impedance	<60ohm
Max. level	+21dBm

Performance

Frequency response (20Hz-20kHz)	+0.5dB
Distortion @ +20dBm	<0.01% @ 1kHz 0.03% 20Hz-20kHz
Equivalent Input noise	<-94dB 22Hz-22kHz unweighted
System noise	
1 Input and	<-92dB 22Hz-22kHz
1 Output @ unity gain	unweighted
8 Inputs and	<-88dB 22Hz-22kHz
1 Output @ unity gain	unweighted
Crosstalk	
Channel to Channel @ 1kHz	-100dBu
Group to Group @ 1kHz	-90dBu

Power Requirements

Voltage	110/120/220/240V 50/60Hz
Consumption	<45VA

Weight

Nett	8kg
Shipping	10.5kg

Dimensions

Width	482mm (19 inch)
Depth	205mm (8 inch)
Height	176mm (7 inch)

Terminations

Inputs

3 pin XLR

Outputs

3 pin XLR

Power

3 pin IEC

Options

Transformer input/output balancing

Circuit Description

The Midas XL88 Matrix Mixer has been designed not only to provide the highest possible quality sound processing facilities, but also the greatest possible degree of reliability. However, no unit of such complexity can be expected never to need service, and to help anyone undertaking such work circuit descriptions will be found below. The less experienced technician or operator may find the following notes useful in an emergency fault finding when more experienced help may not be available.

The priority in fault finding is to adopt a logical approach, as this is the quickest way to identify the precise source of a problem. For instance, if an input module appears to have failed, it will be helpful to establish with greater accuracy where the failure is. Does the direct output function even though the matrix output does not? [Failure in matrix buffer or output.]. Is the signal present at matrix output PFL? [Fault in mute circuit or output amplifier]. In this way a particular circuit block can be identified as faulty, and a careful inspection will often reveal a disconnected wire, a damaged component, or a suspect IC that can be changed. Furthermore, if help is sought over the telephone, it will be helpful to have the greatest possible amount of detail for the technician to work with.

When performing tests on the console, it is tempting to unplug modules without switching off the power supply THIS MUST NEVER BE DONE, AS IT NOT ONLY DESTROYS SOME COMPONENTS AT ONCE, BUT LEADS TO THE EARLY FAILURE OF MANY THAT APPEAR TO HAVE SURVIVED. The power supply is designed to bring the console to full power gradually, which protects sensitive components from damage caused by voltage spikes created by sudden powering up.

Channel Module [Diagram XL88_1,2 & 4]

Eight identical channel modules are fitted. These each consist of two pcbs interconnected by a 20 way IDC cable and a single screened channel assignment jumper. The lower (main) pcb carries all the input and output circuitry with the smaller top pcb holding the matrix mix controls and pfl routing.

The channel input signal appears at XLR socket ST1 pin 3 [hot], 2 [cold] and 1 [gnd] on the main channel pcb (B2700). If no input transformer is fitted, links L1 & L2 are used to bypass the transformer option and the transformers Zobel network components, R9, R10 & C8 are omitted. First order R.F. filtering is provided by R1/C3 and R6/C6, and over-voltage protection by D1/D2 and D3/D4. IC1 operates as a differential amplifier whose common mode rejection is set by VR1 at the factory for maximum rejection [typically 85dB] at 100Hz. The signal then passes through C10 to the Direct output level control and, via the connector ST6 pins 3&4 to the matrix mix level controls on the second pcb.

From the direct output level potentiometer RV1 the signal goes to the non-inverting buffer IC2b, and then to the Main mute switch SW1 as well as to the meter changeover switch SW3. After leaving the mute switch the signal is again buffered and fed to IC3 the balancing network for the direct output which appears at connector ST3 pins 3 [hot] and 2 [cold], the output is protected from excess voltage by the diode bridge D5-8, and set for maximum common mode rejection at 100Hz by VR2 [typically 85dB]. A pin header (ST2) is provided to allow the retrofit of an output balancing transformer. When no transformer is used links are inserted between pins 1&2 and 5&6.

The Zobel network R43/C47 is only fitted when a transformer is incorporated.

The matrix mix level controls on the second pcb (B2701) are each preceded by an on/off switch with associated led indicator. The wipers of the level controls feed the eight common mixing busses via resistors. One buss is jumped from the channel assignment connector ST3/4 back to the main channel board to allocate the group matrix section. The mix group selected will be according to the module location within the main frame.

Group matrix output.

The jumpered input from the matrix mix board feeds a virtual earth summing stage [IC4b] before being passed to the main matrix level fader. After buffering [IC5b], the signal is fed via ST7 to the Matrix mute switch SW2 as well as to the meter changeover switch SW3. After leaving the mute switch the signal is again buffered and fed to IC6 the balancing network for the matrix output which appears at connector ST5 pins 3 [hot] and 2 [cold], the output is protected from excess voltage by the diode bridge D9-12, and set for maximum A pin header (ST4) is provided to allow the retrofit of an output balancing transformer. When no transformer is used links are inserted between pins 1&2 and 5&6.

The Zobel network R44/C48 is only fitted when a transformer is incorporated.

ST7 allows the optional insert unit to be linked into the matrix output chain. When the insert option is not used a jumper is inserted linking pins 1&2.

NOTE: Pin 1 of the input and output XLR's are connected together and to the other channels but not directly to the mixers 0 volt rail.

Channel monitoring.

Both audio and visual monitoring is provided for each channel. The meter changeover switch [SW3] selects whether the direct channel input or group output is to be audibly monitored pre fade or the post fade level monitored on the channel module's output meter.

Output meter

IC7a and b receive, rectify, and calibrate the signal selected by the meter changeover switch SW3. The signal, now a varying positive voltage, is fed to IC7C and d; IC7c has 30dB of gain, which enables D21-D30 to turn on 30dB ahead of D31-D40.

Q2 provides a regulated power source for the LM3915s; Q3 and Q4 are constant current sources for the LED chains.

To calibrate the meter, a signal of 0dB is applied at pin 1 of ST6 [the level can be externally verified at whichever output is driving the meter, selected by the meter changeover switch SW3], and the cathode of D15 is monitored by an oscilloscope. When a symmetrical trace is obtained by adjusting VR4, VR5 is adjusted so that D33 [the 0dB yellow LED] just illuminates. Then the signal is reduced to -30dB, when the LED chain should have only the first three LEDs [D21-D23] illuminated. If the calibration appears to be wrong, the symmetry should be rechecked.

Pre fade routing.

The required pre-fade signal as selected by SW3 is fed via ST6 Pin 2 to the matrix level board. Here it is presented to a DG211 quad analogue switch [IC1] configured as a 'T' switch for maximum off isolation.

As with the matrix group mix buss input, the channel is assigned to a pfl channel corresponding to the module location in the main frame. This is accomplished by inserting the appropriate jumper in ST5/6.

The pfl select lines are distributed along the same ribbon cable as the mix lines and enter the module via ST2 pins 12 thro' 19. These select lines are normally high [+15V]. They are brought to 0V to enable the channel pfl output.

When enabled, the channel pfl output appears on the pfl mix buss via ST2 pin 10.

Switch LED powering.

The status LEDs are powered by the current source based around Q1. The order for the chain starting from Q1 is main mute, meter changeover & matrix mute on the main board. It then loops via ST6 pin 17 to the sub board. From here it goes to the matrix on/off switches 1 thro' 8. The chain finishes at the negative rail.

PFL Mix & Output Module [Diagram XL88_3]

The channel module pfl lines are individually selected by the eight push buttons with associated Led indicators that are located on this pcb [B2702]. The pushes keep the select lines high [+15V] in the off state and at 0V in the selected (on) state.

The select lines are fed to the modules via the ribbon cable buss connected to ST1. The pfl audio mix buss enters the module via ST1 pin 10. It is buffered by IC1a and the signal fed to IC2 the balancing network for the Pfl output which appears on three terminal pins 'H' [hot] 'C' [cold] and 'G' [gnd], the output is protected from excess voltage by the diode bridge D9-12, and set for maximum common mode rejection at 100Hz by VR1 [typically 85dB].

The three terminal pins are connected by screened cable to the rear panel mounted XLR PFL Output socket pins 1 [G], 2 [C] and 3 [H].

The facility to link together the pfl mix buss of more than one XL88 mixer exists on the pfl board. Two terminal pins are fitted 0V and Sig. These give direct pfl buss input. If this is to be used, the 3 pin Pfl output xlr should be replaced with a 5 pin xlr, the pfl output should be connected to pins 1, 2 and 3 as above and the pfl buss input should be connect to pins 4 [0V] and 5 [SIG].

Switch LED powering.

The status LEDs are powered by the current source based around Q1. The order for the chain is from Q1 to the pfl select switches 1 thro' 8 and then to the negative rail.

Module power connection.

The mixer power supply connects to ST2 on this module. From here it is distributed to all other modules by the main ribbon cable. 40 pin headers are used for the channel modules with a 20 pin header on the pfl module. The first eight ways are used for this purpose as follows:-

- PIN 1 & 2 - Input/output gnd.
- PIN 3 & 4 - Psu 0 Volts.
- PIN 5 & 6 - Psu -15 Volts.
- PIN 7 & 8 - Psu +15 Volts.

Earth lift.

The input and output sockets have pin 1 (Gnd) common. This is not connected to the psu 0V as the latter is linked to mains earth. The XL88 is normally used with another console and the audio ground is established there.

If however it is desired to use the XL88 as a stand alone unit, the grounds may be connected internally by fitting a link in the '0V LINK' location by the side of ST1 on the Pfl mix & output module. A high value resistor may be found in this location to facilitate testing. This should be removed.

Power Supply

The power supply provides the two power rails required for the successful operation of the XL88 matrix mixer.

PLEASE NOTE THAT THE POWER SUPPLY CONTAINS CIRCUITRY WHICH GENERATES LETHAL VOLTAGES. ALL SERVICING OF THESE UNITS MUST BE REFERRED ONLY TO AUTHORISED SERVICE AGENTS OF KLARK TEKNIK plc. ON NO ACCOUNT MUST SERVICE WORK BE ATTEMPTED BY ANYONE ELSE. IF IT IS, THE WARRANTY WHICH COVERS THE EQUIPMENT BECOMES INVALID, AND KLARK TEKNIK plc ACCEPT NO LIABILITY FOR CONSEQUENT DAMAGE TO THE CONSOLE OR ANCILLARY EQUIPMENT.

Voltage Changeover.

It is most important that power is not applied to the unit when changeover procedures are incomplete, and that the power is disconnected by unplugging the mains lead before work is commenced.

1. Change the fuse.

The fuse holder is located on the back of the unit above the mains input plug. The correct fuse ratings are as follows:-

220/240 volt operation: 1A.(T)

100/110 volt operation: 1A.(T)

The fuse is 20mm, HBC type.

2. 120/240 Changeover.

The voltage change over switch is located at the rear of the chassis and its setting is clearly marked. The voltage label plate must be unscrewed to allow the setting to be changed. Ensure it is replaced after adjustment.

3. 110/220 Changeover

This is carried out as above for the 120/240 changeover. It will require that the appropriate mains transformer has been fitted. This is ascertainable by the fact that the voltage selector cover plate is printed 110 & 220. If this is not the case, please contact your nearest Klark-Teknik representative to arrange for the transformer to be changed.

Power Supply Assembly. [Diagram XL88_PSU]

This contains the Mains transformer, fuses, voltage selection, rectifiers and linear regulators. Both negative and positive sections of the supply are identical with there own full wave rectifier, smoothing capacitor and 1.5A fixed voltage regulator.

The regulators are mounted off the board on a common heatsink and connected to the pcb by short jumper leads. The output from the psu is linked to the Pfl, mix and output board by a jumper lead and plug.

Warranty

This product is manufactured by Midas and warranted to be free from defects in components and factory workmanship under normal use and service for a period of one year from the date of purchase.

During the warranty period, Midas will undertake to repair or at its option, replace this product at no charge to its owner when failing to perform as specified, provided the unit is returned shipping pre-paid, to the factory or authorised service facility.*

No other warranty is expressed or implied.

This warranty shall not be applicable and be void when this product is subjected to:

- a) Repair work or alteration by persons other than those authorised by Midas in such a manner as to injure, in the sole judgement of Midas, the performance, stability, reliability or safety of this product.
- b) Misuse, negligence, accident, act of God, war or civil insurrection.
- c) Connection, installation, adjustment or use otherwise than in accordance with the instructions provided by Midas.

* See enclosed service request form.

Midas reserves the right to alter specifications without notice. This warranty does not affect the statutory rights of the UK customer.

COPYMASTER DO NOT REMOVE

NOTE! This sheet is your Copymaster. Please duplicate on photocopier when needed.

Service Request Form

Please complete this form and send it to Klark-Teknik before returning the unit. Attach duplicate to the returned unit.

NAME.....TELEPHONE.....

A D -
DRESS.....

MODEL No.....SERIAL No.....

PURCHASED FROM.....DATE.....

Please tick appropriate box

REPLACEMENT PACKAGING REQUIRED YES NO

- 1) Describe symptoms of malfunction.
- 2) Which channel(s) exhibit(s) the problem?
- 3) Under what conditions does the problem occur?

- a) All the time
- b) After a while
- c) At high signal levels
- d) At high temperatures
- e) Other (please explain)

Is the fault: Permanent Intermittent

- 4) What did you do to isolate the problem to this unit?
- 5) Further comments.

Important Note

It is often useful to call your dealer or the factory explaining the nature of the problem with the unit. In many instances the problem can be solved without returning the unit to the factory. If the unit has to be returned to the factory, use the original packing only. If you do not have the original packing, we will provide a replacement.

Factory authorised service facilities are located throughout the world. Call your dealer or the factory for the location of the service facility nearest you.

EVI Pro Audio Group
Klark Teknik Building
Walter Nash Road
Kidderminster
Worcestershire
DY11 7HJ

Tel: (01562) 741515
Fax: (01562) 745371