

## Xi-1153/64 X-Array Install™

### Three-Way, Full-Range, Sound-Reinforcement System

- Full Ring-Mode Decoupling (RMD™)
- Two-Element-Line-Array mid/low configuration for vertical direction control to 200 Hz
- Ultra-compact/high-level, three-way design
- EVX-155 low-frequency section: Excellent linear excursion superior thermal capability
- New design, 12-inch mid-bass driver (60° x 40°)
- Coaxially-mounted HF section includes DH6 compression driver for very high output, extremely rigid piston range performance
- Fully rotatable HF section for vertical or horizontal suspension

#### Description

Introducing a family of advanced sound reinforcement products for everyone who desires the sound quality of Electro-Voice's X-Array™ touring systems. X-Array Install™ is the ideal choice for small-to-medium array configurations and fixed installations of any size.

Inspired by the most demanded features of EV's acclaimed X-Array™ touring systems, the X-Array Install™ series incorporates a potent combination of very high output, medium- to long-throw "cells," and Ring-Mode Decoupling (RMD™).

#### RMD™

RMD™ (Ring-Mode Decoupling) is the same advanced technology built into the X-Array™ touring series. RMD™ produces substantially improved tonal character and fidelity whether operated at low or extremely high sound pressure levels. RMD™ attacks time domain "ringing modes" at their sources. Mechanical solutions resolve mechanical issues, and acoustical solutions address acoustical modes found in all sound reinforcement systems. The combination of each RMD™ technique provides improved tonal character and fidelity at increasing drive

levels. The result is clear, even sound quality with vastly improved intelligibility.

#### Xi-1153/64 and Two-Element Line Array

These triamp-ready, three-way systems in a unique two-element-line-array configuration are designed for use in reverberant spaces. One woofer flanks and works with the mid-bass horn to form the line array, extending vertical directivity control to below 200 Hz. Such wide-bandwidth control and the medium-Q (60° x 40°) pattern provide superior direct-to-reflected SPL ratios and improved system intelligibility, and suppress feedback below arrays.

When optimum directivity control is required, the Xi-1153/64 with a single 15-inch woofer (EVX-155), should be used. The 12-inch mid-bass driver features RMD™ coupled with a 60° x 40° vertical horn.

The high-frequency system uses a DH6 large-format compression driver with a rotatable 60° x 40° horn. It is coaxially mounted, asymmetrically positioned and fully "shrouded" to preserve mid-bass wave-front detail. For extended-bass/subbass, the Xi-1153/64 may be used with the Xi-1191 subwoofer.

#### Applications

The Xi-1153/64 is ideally suited for high-level, high-fidelity applications. The extended capabilities, of the system, particularly the low-frequency capability and vertical polar control allow the system to be used very successfully without the need of a subwoofer. For application of low-frequency sound pressure levels coupled with very accurate vocal reproduction, the Xi-1153/64 may be coupled with the Electro-Voice Xi-1191 subwoofer.

#### Power-Handling Test

Electro-Voice components and systems are manufactured to exacting standards to ensure reliability in continuous use in arduous real-life conditions. Besides utilizing industry-standard power tests, extreme in-house power tests which push the performance boundaries of the loudspeakers are also performed for an extra measure of reliability. The Xi-1153/64 systems are rated per ANSI/EIA RS426-A 1980 Loudspeaker Power Rating, Full Range Test, which uses a shaped-random-noise signal to simulate typical music to test the mechanical and thermal capabilities of the loudspeakers.

# X-Array Install™ Xi-1153/64 Loudspeaker System

The ISP-100 digital electronic unit was used to provide the necessary crossover filters and equalization during power testing. Specifically, the Xi-1153/64 passes the ANSI/EIA RS426-A power test with the following test parameters:

## Low-Frequency Section:

$P_{E(MAX)}$ :	600 watts
Test Voltages:	58.7 volts rms 117.4 volt speak
$R_{SR}(1.15 R_E)$ :	5.75 ohms

## Mid-bass Section:

$P_{E(MAX)}$ :	300 watts
Test Voltages:	45.5 volts rms 91 volts peak
$R_{SR}(1.15 R_E)$ :	6.9 ohms

## High-Frequency Section:

$P_{E(MAX)}$ :	75 watts
Test Voltages:	30.1 volts rms 60.2 volts peak
$R_{SR}(1.15 R_E)$ :	12.1 ohms

## Crossover, Equalization And Time-Delay Controller

The Xi-1153/64 speaker system and variants are designed as an integrated package that utilizes the Merlin ISP100, Klark Teknik DN8000 or Electro-Voice Dx34A digital crossover system. Optimal performance of the Xi-1153/64 speaker system can only be assured when using the above controllers. For the three-way, non-overlap crossover configuration, either the merlin ISP-100, DN8000 or Dx34A may be used. For the two-element-line-array configuration, however, only the Merlin ISP-100 may be used.

## Electrical Connection And System Wiring

Electrical connections to the Xi-1153/64 are made on the back of the enclosure via a 8-pin connector. There are two connectors on the input panel to allow paralleling of other Xi-1153/64 systems. The Neutrik Speakon® NL8MPR is used for both connections. The pin assignments are as follows:

HF:	Pin 4 In / Pins 4 Out
MB:	Pin 3 In / Pins 3 Out
LF:	Pin 1 In / Pins 2 Out

The wiring diagram of the loudspeaker system is shown in figure 7. The electrical impedance is shown in Figure 6.

## Amplifier Recommendations

Power amplifiers with the following ratings are recommended for use with the Xi-1153/64 speaker systems:

LF: 600-800 watts continuous into 8 ohms.  
MB: 300-600 watts continuous into 8 ohms.  
HF: 125-250 watts continuous into 8 ohms.

Xi-1153/64 speakers may be paralleled only with other Xi-1153/64 speakers if the amplifier is capable of delivering full power at the lower impedances. The use of amplifiers with lower power ratings is acceptable; however, the full-power capabilities of the Xi speakers will not be realized. The use of amplifiers with significantly higher power ratings will generate maximum dynamic range and fidelity, but care must be utilized for longer duration signals as mechanical and thermal damage is possible in the system.

## Flying the Xi Systems

A manual entitled the *X-Array Install™ Flying Manual* is available from Electro-Voice, and is included with each flying Xi loudspeaker system. A brief introductory overview is included here. The *X-Array-Install™ Flying Manual* should be consulted for complete structural specifications and detailed information on safely suspending and using the Xi systems.

The Xi systems incorporate a unique two-point flying system that permits a wide range of vertical angle adjustment, and offers maximum flexibility in array design for both touring sound and permanent installations. The quick-release, aircraft-rated heavy-duty L-track-type hardware design allows arrays of loudspeakers to be assembled (and disassembled) very quickly, and offers such flexibility in the vertical angling of cabinets that pull-up points are usually unnecessary. Furthermore, all of the flying Xi loudspeaker models include the same rigging hardware, allowing different models to be mixed as necessary throughout an array.

The working-load limit (for an 8:1 safety factor) for each rigging point on the Xi loud-

speaker enclosure is 227 kg (500 lb) for a 0° pull angle and 170 kg (375 lb) for a 90° pull angle when used with the New Haven NH32101-2 double-stud fitting, and 113 kg (250 lb) at any angle when used with the New Haven NH8192-2S or Ancra 42546-10 single-stud fittings with locking pins. The working-load limit (for an 8:1 safety factor) for the overall enclosure is 453 kg (1,000 lb). (Consult the *X-Array Install™ Flying Manual* for specific structural ratings and limitations.) The enclosures may be oriented with the rigging track on the sides of the enclosure, or on the top and bottom, and may be daisy-chained together as long as the safety factor is 8:1 or greater, and local regulations are met. For fire safety and additional structural strength in both flying orientations, top-to-bottom and side-to-side metal straps link the rigging track inside the enclosure. All associated rigging is the responsibility of others.

**CAUTION: The Xi loudspeaker system should be suspended overhead only in accordance with the procedures and limitations specified in the *X-Array Install Flying Manual* and manual updates notices.**

## Field Replacement

Normal service for the Xi requires only a #2 Phillips screwdriver and a 3/16-inch hex-key wrench. The drivers may be accessed as follows:

HF: First remove the grille, then remove the screws securing the front flange of the high-frequency horn. Peel the hook and loop fastener strips from the four corners of the foam shroud and remove the four sides of the shroud. Lift the horn and driver out of the wood assembly. In the event of failure, the diaphragm assembly can be replaced with the driver attached to the horn.

MB: Remove the screws securing the hatch on the back of the enclosure and lift the hatch out. Remove the screws securing the 12-inch woofer and lift the driver out of the enclosure. In the event of failure, the entire woofer must be replaced.

LF: First remove the grille, then remove the screws securing the hatch on the front of the enclosure. Remove the screws securing the 15-inch woofer and lift the driver out of the

# X-Array Install™ Xi-1153/64 Loudspeaker System

enclosure. In the event of failure, the entire woofer must be replaced.

The following replacement parts are available from Electro-Voice Service in Buchanan, Michigan:

LF: Complete woofer: EV Part No. 815-3075

MB: Complete woofer: EV Part No. 812-3074

HF: Diaphragm kit; EV Part No. 84233-XX

## Architects' and Engineers'

### Specifications:

The loudspeaker system shall be a three-way tri-amp system. The system shall have an 15-inch, low-frequency loudspeaker with a nominal impedance of 8 ohms and a 4 inch aluminum voice coil. The low-frequency loudspeaker shall have a power handling capacity of 600 watts with a shaped pink-noise signal with a 6-dB crest factor for 8 hours (as per ANSI/EIA RS-426 A) The mid-bass loudspeaker shall be a fully horn-loaded, 12-inch driver with a 2.5-inch voice coil and a nominal impedance of 16 ohms. The system shall maintain vertical pattern control to 400 Hz. The high-frequency section shall be coaxially mounted in the mid-bass horn and shall employ a compression driver capable of handling 75 watts, 1,760- to 20,000-Hz when pink noise of a 6-dB crest factor is applied for 2 hours (as per AES 2-1984 and ANSI S4.26-1984 standards). The loudspeaker shall be constructed of 18-mm, 13-ply birch and shall be trapezoidal in shape. The wedge angle shall be 18-degrees.

The system shall be capable of very-high-level operation with a band width of 80 to 20,000 Hz. The system dimensions shall be 586 mm (23.07 inches) wide by 914 mm (36.00 inches) high by 759 mm (29.88 inches) deep. The system shall employ flying hardware of a "track" style and two tracks on the enclosure top and two tracks on the enclosure bottom (top and bottom reference to the 36-inch dimension.)

The loudspeaker shall be the Electro-Voice Xi-1153/64.

### Uniform Limited Warranty

Electro-Voice products are guaranteed against malfunction due to defects in mate-

rials or workmanship for a specified period, as noted in the individual product-line statement(s) below, or in the individual product data sheet or owner's manual, beginning with the date of original purchase. If such malfunction occurs during the specified period, the product will be repaired or replaced (at our option) without charge. The product will be returned to the customer prepaid. Exclusions and Limitations: The Limited Warranty does not apply to: (a) exterior finish or appearance; (b) certain specific items described in the individual product-line statement(s) below, or in the individual product data sheet or owner's manual; (c) malfunction resulting from use or operation of the product other than as specified in the product data sheet or owner's manual; (d) malfunction resulting from misuse or abuse of the product; or (e) malfunction occurring at any time after repairs have been made to the product by anyone other than Electro-Voice Service or any of its authorized service representatives. Obtaining Warranty Service: To obtain warranty service, a customer must deliver the product, prepaid, to Electro-Voice Service or any of its authorized service representatives together with proof of purchase of the product in the form of a bill of sale or receipted invoice. A list of authorized service representatives is available from Electro-Voice Service at 600 Cecil Street, Buchanan, MI 49107 (800/234-6831 or FAX 616/695-4743). Incidental and Consequential Damages Excluded: Product repair or replacement and return to the customer are the only remedies provided to the customer. Electro-Voice shall not be liable for any incidental or consequential damages including, without limitation, injury to persons or property or loss of use. Some states do not allow the exclusion or limitation of incidental or consequential damages so the above limitation or exclusion may not apply to you. Other Rights: This warranty gives you specific legal rights, and you may also have other rights which vary from state to state.

**Electro-Voice Speakers and Speaker Systems** are guaranteed against malfunction due to defects in materials or workmanship for a period of five (5) years from the date of original purchase. The Limited Warranty does not

apply to burned voice coils or malfunctions such as cone and/or coil damage resulting from improperly designed enclosures. Electro-Voice active electronics associated with the speaker systems are guaranteed for three (3) years from the date of original purchase. Additional details are included in the Uniform Limited Warranty statement.

**Electro-Voice Accessories** are guaranteed against malfunction due to defects in materials or workmanship for a period of one (1) year from the date of original purchase. Additional details are included in the Uniform Limited Warranty statement.

**Electro-Voice Flying Hardware** (including enclosure-mounted hardware and rigging accessories) is guaranteed against malfunction due to defects in materials or workmanship for a period of one (1) year from the date of original purchase. Additional details are included in the Uniform Limited Warranty statement.

For warranty repair, service information, or a listing of the repair facilities nearest you, contact the service repair department at: 616/695-6831 or 800/685-2606.

**For technical assistance**, contact Technical Support at 800/234-6831 or 616/695-6831, M-F, 8:00 a.m. to 5:00 p.m. eastern standard time.

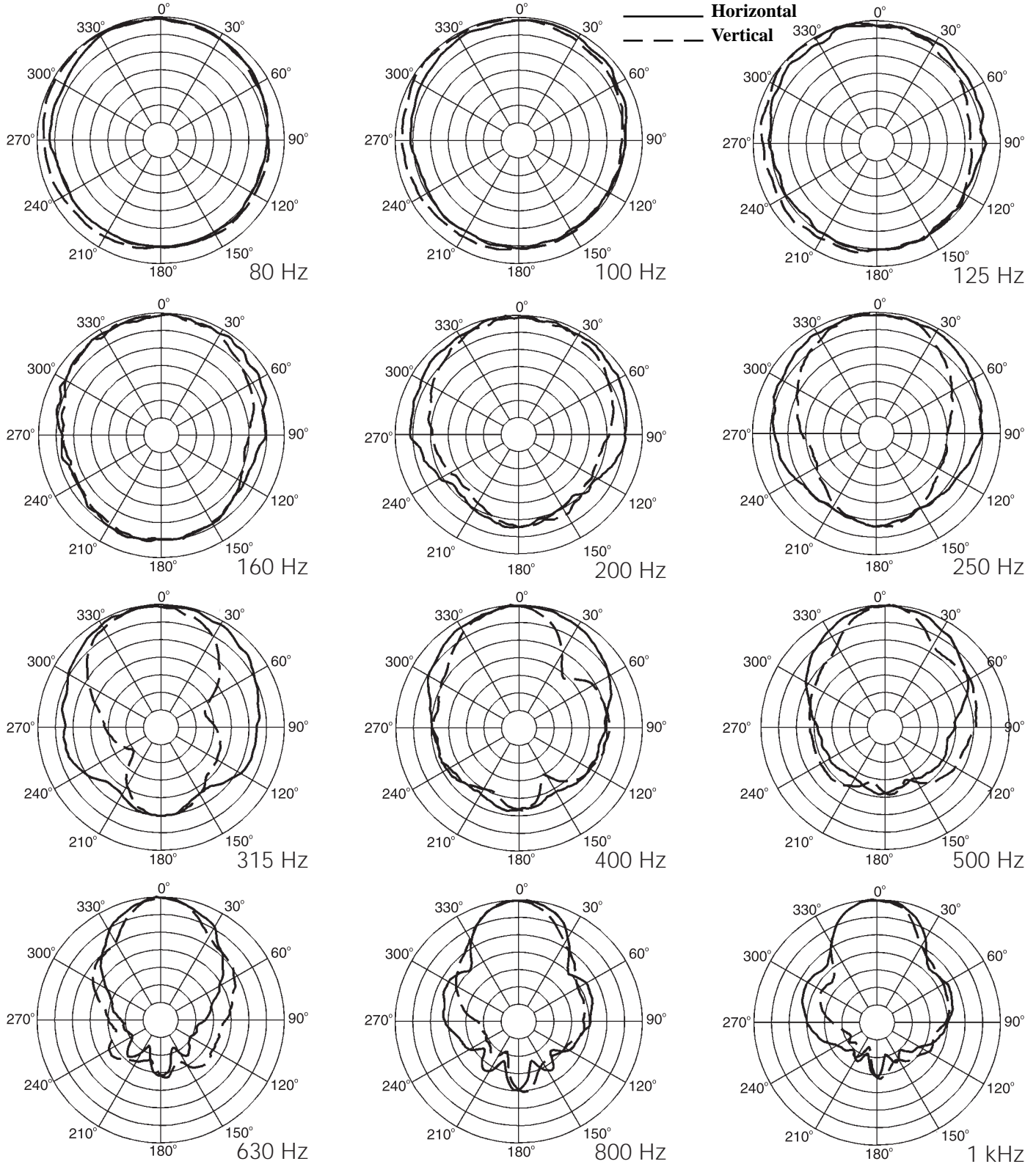
Specifications subject to change without notice.

# X-Array Install™ Xi-1153/64 Loudspeaker System

**Figure 1—Polar Response**

The directional response of the system was measured in an anechoic environment at a distance of 6.1 m (220 feet) using 1/3-octave-filtered pink noise with a full spherical measurement system. The ISP-100 digital electronic unit was used to provide the necessary crossover filters, equalization and time delay. The polar response of the loudspeaker system at selected 1/3-octave frequencies is shown. The selected frequencies are representative of the polar response of the system. The horizontal polar is from the perspective of looking down on the top of the loudspeaker, where 270° is to the left and 90° is to the right. The vertical polar is from the perspective of looking at the side of the loudspeaker, where 90° is to the top and 270° is to the bottom. 0° is directly on axis of the loudspeaker both horizontally and vertically.

X-Array Install™ Xi-1153/64 Loudspeaker System

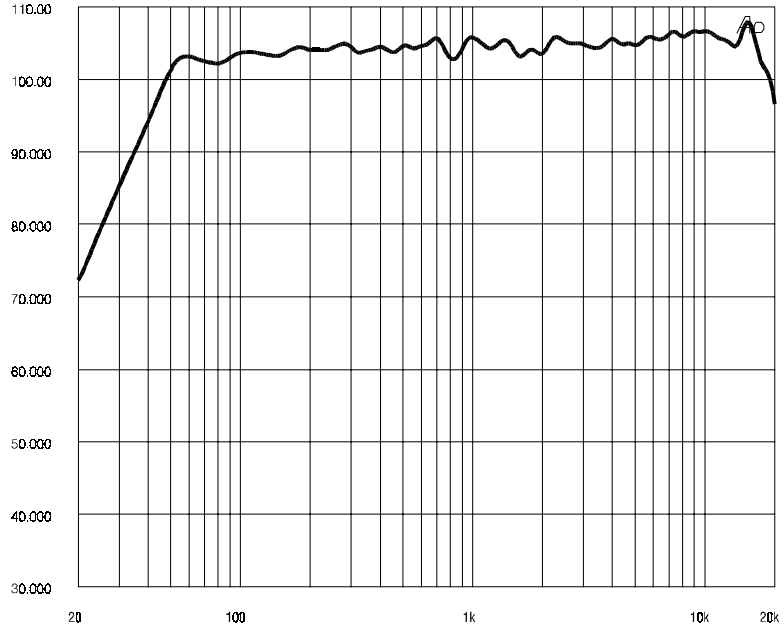




# X-Array Install™ Xi-1153/64 Loudspeaker System

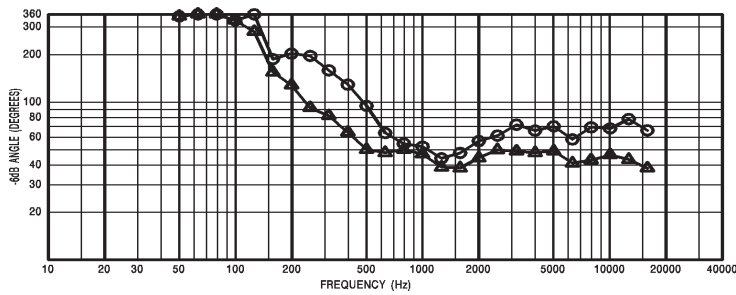
**Figure 2—Frequency Response**

The frequency response of the system was measured on axis in the farfield in an anechoic environment using a swept sine-wave signal. The ISP-100 digital electronic unit was used to provide the necessary crossover filters, equalization and time delay. One watt of power (2.83 volts rms at 250 Hz) was applied to the midband of the midbass section. The sound-pressure level was normalized for an equivalent one-meter distance.



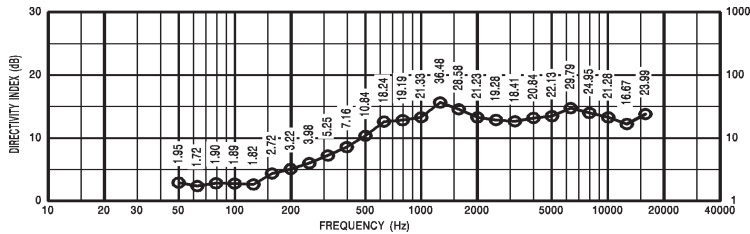
**Figure 3—Beamwidth**

The beamwidth of the system, (i.e., the included horizontal and vertical coverage angles at the -6-dB points) was measured with a full spherical measurement system as described in *Polar Response*.



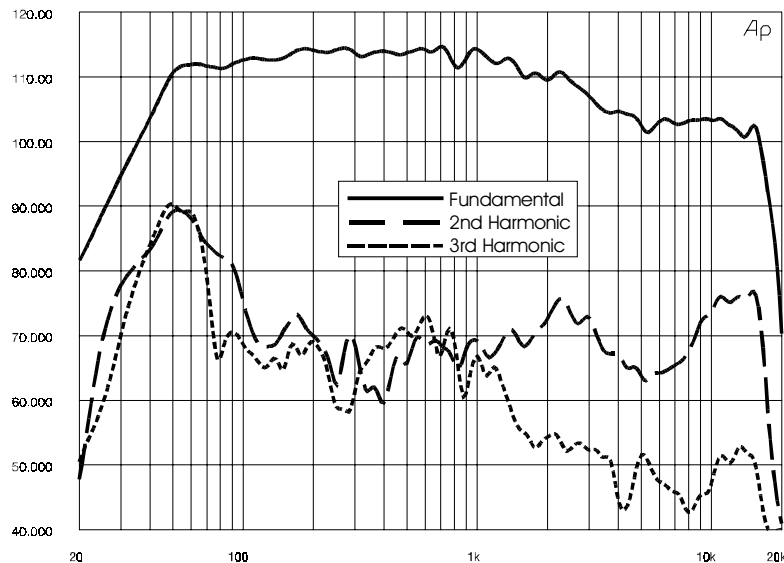
**Figure 4—Directivity**

The directivity index,  $D_p$ , and directivity factor,  $R_0$ , of the system were measured with a full spherical measurement system as described for the Polar Response.



**Figure 5—Distortion**

Distortion for the system was measured on axis in the farfield in an anechoic environment with an input signal that would result in a sound-pressure level of 115 dB at one meter. The Dx34 digital electronic unit was used to provide the necessary crossover filters, equalization and time delay. A frequency spectrum typical of close-miked rock music was employed. The sound-pressure level was normalized for an equivalent one-meter distance. Plots of second and third harmonic distortion are shown referenced to the fundamental.

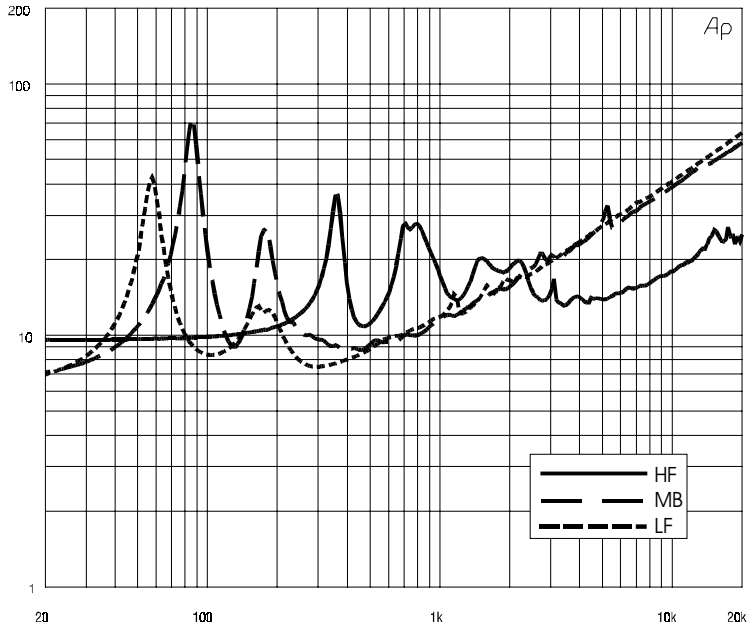




# X-Array Install™ Xi-1153/64 Loudspeaker System

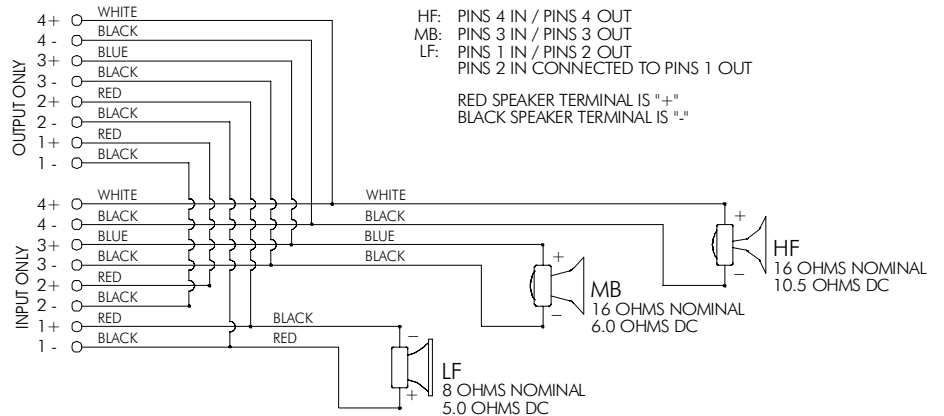
**Figure 6—Impedance**

The impedance of each frequency band of the system was measured in an anechoic environment.

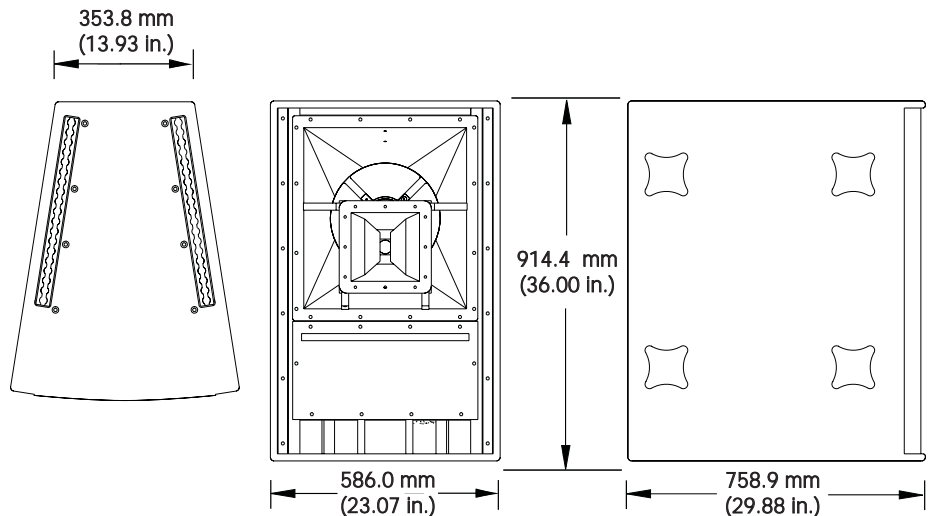


**Figure 7—Wiring Diagram**

The wiring diagram of each frequency band of the system is shown.



**Figure 8—Dimensions**



# X-Array Install™ Xi-1153/64 Loudspeaker System

## Specifications:

**Frequency Response** (measured in far field, calculated to one meter on axis, swept sine wave, one watt into MB section -2.83 V at 250 Hz, anechoic environment; see Figure 2):

48-20,000 Hz

**Crossover Frequency:**

160 and 1,480 Hz

**Efficiency,**

**LF/MB/HF:**

1.7/18/25%

**Maximum Long-Term-Average Power-Handling Capacity** (per ANSI/EIA RS-426-A 1980),

**LF/MB/HF:**

600/300/75 watts

**Maximum Long-Term-Average Midband Acoustic Output, LF/MB/HF:**

10/54/15 acoustic watts

**Sensitivity** (SPL at one meter, indicated input power, anechoic environment, average level),

**LF/MB/HF,**

**1/1/1 watt:**

91.5/107.0/110.0 dB

**600/300/75 watts:**

119.3/131.8/131.8 dB

**Beamwidth** (angle included by 6-dB-down points on polar responses, indicated one-third-octave bands of pink noise; see Figures 1 and 3),

**Horizontal, 800-16,000 Hz:**

60° (+16°, -6°)

**Vertical, 800-16,000 Hz:**

40° (+10°, -2°)

**Directivity Factor,  $R_0$  (Q), 800-16,000 Hz Average** (see Figure 4):

23.1 (+13.4, -6.5)

**Directivity Index,  $D_i$ , 800-16,000 Hz Average** (see Figure 4):

13.6 dB (+2.0 dB, -1.4 dB)

**Distortion** (115 dB SPL at one meter, shaped spectrum; see Figure 5),

**Second Harmonic,**

**100 Hz:**

1.4%

**500 Hz:**

0.4%

**2,000 Hz:**

1.4%

**5,000 Hz:**

1.1%

**Third Harmonic,**

**100 Hz:**

0.6%

**500 Hz:**

0.7%

**2,000 Hz:**

0.2%

**5,000 Hz:**

0.3%

**Transducer Complement,**

**HF:**

DH6-16 driver, HP-type 60° x 40° horn

**MB:**

DL-type 12-in. woofer, 60° x 40° horn

**LF:**

EVX-155, 15-in. woofer

**Impedance** (see Figure 6),

**Nominal,**

**LF/MB/HF:**

8/16/16 ohms

**Minimum,**

**LF/MB/HF:**

7.5/8.7/13.1 ohms

**Input Connections:**

Two Neutrik NL8MPR Speakon® connectors paralleled

**Recommended Amplifier Power,**

**HF:**

125-250 watts

**MB:**

300-600 watts

**LF:**

600-800 watts

**Enclosure Construction,**

**Enclosure Shell:**

18 mm, 13-ply birch plywood

**Finish:**

Black textured paint

**Grille:**

Vinyl-coated steel with foam

**Rigging:**

Two-point heavy-duty L-track system, accepts New Haven NH32102-2 double-stud fittings, or New Haven NH8192-2S or Ancra 42546-10 single-stud fittings with safety pins

**Dimensions,**

**Height:**

914 mm (36.00 in.)

**Width (front):**

586 mm (23.07 in.)

**Width (back):**

354 mm (13.93 in.)

**Depth:**

759 mm (29.88 in.)

**Angle:**

18° wedge

**Net Weight:**

93.0 kg (205 lb)

**Shipping Weight:**

97.1 kg (214 lb)

## Electro-Voice®

600 Cecil Street, Buchanan, MI 49107

800/234-6831, 616/695-6831, 616/695-1304 Fax

©Telex Communications, Inc. 1998 • Litho in U.S.A.