

Xb

X-Array™ Bass System

- Unprecedented acoustic output in a small, lightweight package
- Ring-Mode Decoupling (RMD)™ provides accurate transient detail
- EVX-180B woofers
- Unique rear-hinge rigging
- Enclosure shell and rigging identical to all of the full-size X-Array™ systems

Description

The X-Array™ product line represents important advancements in concert-sound reinforcement technology. The design goals called for the highest acoustic output capability with the highest fidelity in lightweight, compact enclosures that were easy to array. The development began with a clean sheet of paper and took an integrated approach. The individual loudspeaker drivers, horns, enclosures, rigging hardware and system configurations were designed from the ground up specifically for this high-performance application.

The Xb is a manifolded, vented-box bass system utilizing two 457-mm (18-in.) woofers. The two woofers face each other in a manifold chamber at the center of the enclosure. This manifolding technique (U.S. Patent Number 4,733,749) increases the acoustic loading, resulting in increased low-frequency efficiency (at and slightly above box tuning) and reduced distortion compared to conventional direct-radiating designs. The woofers were designed as part of the Xb development and represent a step forward in state-of-the-art loudspeaker design in terms of high acoustic output with low distortion and low power compression. Electro-Voice engineers developed a new technology dubbed Ring-Mode Decoupling

(RMD™) to substantially improve clarity and intelligibility by reducing both linear and nonlinear resonance modes that color the sound.

The low-frequency driver in the Xb is the EVX-180B. An improved version of the industry-standard EVX-180A high-excursion 467-mm (18-in.) woofer that has distinguished itself as an industry standard for high-power, low-frequency reproduction. During the X-Array™ development, the thermal conduction of the motor was improved and the suspension was redesigned, giving the EVX-180B even lower power compression and a longer mechanical lifetime. In the Xb, the woofers are manifolded in a vented enclosure optimized for maximized output from 37-160 Hz with minimized distortion. Ring-Mode Decoupling, (RMD™), is a technique utilized and named by Electro-Voice to describe a process used to improve sound quality in loudspeaker systems. RMD offers a solution to a very fundamental problem. It has long been recognized that two different loudspeaker systems can sound different even though they both may be equalized to have the same frequency response. This difference is due to a variety of resonances, or ring modes that color the sound. Although this ringing may be very low in level compared to the program material, it is still audible. The source of these resonances may

be mechanical or acoustical in nature, or a combination of both. In addition, they may be linear or nonlinear, resulting in their character changing with level. Furthermore, these ring-modes may be aggravated when multiple loudspeaker enclosures are assembled into arrays. The result is a coloration that decreases intelligibility and clarity, with the nature of that coloration varying with level. Often, the listener perceives that coloration as imbalance in the frequency response, and will attempt to electronically adjust the system to restore the spectral balance. However this electronic equalization has the negative effect of changing the program material itself.

Ring-Mode Decoupling (RMD™) addresses mechanical resonances with mechanical solutions, and acoustical resonances with acoustical solutions. In the Xb development, RMD was applied at every level – to the individual LF drivers, the LF enclosure chambers and the interaction between multiple enclosures. The design process included, for example, the driver cone, suspension geometry and materials, enclosure geometry and materials, absorptive materials, etc. The result is a dramatic improvement in clarity and with a much more neutral sound (a lack of coloration) with the loudspeaker system maintaining its sonic integrity from the very-lowest sound pressure levels to the very-

Xb Bass System

highest sound pressure levels. This means that the front-of-house engineer will not have to retune the EQ and level settings as the SPL is increased throughout the show. This also means that the sound-system performance will remain consistent in different array configurations and from venue to venue.

The X-Array™ systems utilizes a unique rigging system. A hinge assembly is used to link cabinets together at their rear corners, while wire-ropes/fitting assemblies are used at the front to adjust the relative angle between systems. (See the *Flying the X-Array™ Systems* section for more details.)

The durable Xb enclosure is constructed of 18-mm, 13-ply birch plywood and has a wear-resistant black, textured paint finish. The system is trapezoidal, forming an 18° wedge and includes a heavy-duty steel grille with a water-resistant charcoal-gray foam interlining. The enclosure features vinyl bumper pads on the front corners to and feet on the bottom to resist wear.

A variety of accessories are available for the X-Array™ loudspeaker systems, including rigging hardware, dollies, covers, electronic crossovers, amplifier racks and speaker cabling. Consult the *X-Array™ Accessories* section for a complete listing of the available accessories

Applications

The X-Array™ loudspeaker systems were designed for optimal performance in both concert-sound and permanent-installation applications where studio-monitor sound quality is required at concert-sound levels. The X-Array™ loudspeaker systems work well individually, in small arrays and in large arrays. The high acoustic output from these compact, lightweight systems provide the highest acoustic-power-to-weight ratio, the highest acoustic-power-to-frontal-area ratio, and the highest acoustic-power-to-bulk-volume ratio in the industry. That means that X-Array™ systems will be considerably smaller and lighter compared to competitive systems having equivalent acoustic output. With its response from 37-160 Hz, the Xb is recommended for low-frequency applications where very-high levels of bass are required from a compact enclosure. Spe-

cifically, the Xb has been optimized to provide low-frequency reinforcement for the mid-bass-/high-frequency X-Array™ systems (like the Xf or Xcn) and the MB/HF or LF/MB/HF X-Array™ systems (like the Xn). The Xb may be used individually or in multiples to construct low-frequency arrays, or may be used with the mid-bass-/high-frequency or low-/mid-bass-/high-frequency X-Array™ loudspeaker systems to construct large full-range arrays. The Xb enclosure shell and rigging are identical to the other full-size X-Array™ systems for easy array integration. The Xb would be well suited for front-of-house, front-fill, side-fill applications and down-fill applications.

The Xb is intended to be used with other X-Array™ systems for a full-range response as an active system that requires an active electronic crossover. Both the Electro-Voice Dx38 and Klark Teknik DN8000 digital crossovers are recommended for signal control. (See the *Crossover, Equalization and Signal Delay Controller* section.) The Electro-Voice P3000 amplifier is recommended for powering the Xb. (See the *Amplifier Recommendations* section.)

Power-Handling Capabilities

The Xb systems are rated as per the “ANSI/EIA RS-426-A Loudspeaker Power-Rating, Full-Range Test,” which uses a shaped-random-noise signal to simulate typical music to test the mechanical and thermal capabilities of the loudspeakers. A digital crossover was used to provide the appropriate filtering and equalization. The test parameters are as follows:

Low-Frequency Section (Pins 1 and 2 paralleled):

$P_{E(MAX)}$:	1,200 watts
Test Voltage:	58.7-volts rms 117.4-volts peak
$R_{SR} (1.15R_E)$:	2.88 ohms

Amplifier Recommendations

Power amplifiers with the following ratings are recommended for use with the Xb loudspeaker systems:

LF:	800 watts per channel into 8 ohms
-----	--------------------------------------

93-volts rms short term
132-volts peak

Xb loudspeakers may be paralleled with other Xb systems as long as the amplifiers can drive the lower impedances. To maintain a sufficient damping factor with long cable runs, amplifier loads of four ohms per channel are recommended. The Electro-Voice P3000 amplifiers are ideal for powering the X-Array™ systems.

Crossover, Equalization and Signal Delay Controller

The Xb is intended to be used with other X-Array™ loudspeaker systems (like the Xf or Xn, for example) to construct full-range arrays as an active system requiring an active crossover, equalization and signal delay controller. For basic applications, the Electro-Voice Dx38 2-in/4-out controller is recommended. For more sophisticated applications, the Klark Teknik DN8000 2-in/5-out controller is recommended. Linkwitz-Riley crossover filters with a minimum slope of 24 dB per octave at 125 Hz and 1,760 Hz are recommended, and subsonic filter protection at 42 Hz or higher with a minimum slope of 12-dB/octave is recommended in the low-frequency section. Both the Dx38 and the DN8000 offer appropriate filtering, equalization and signal delay capabilities to provide optimum performance of the X-Array™ loudspeaker systems. Digital parameter settings for both controllers are available upon request.

Electrical Connection and System Wiring

Two paralleled Neutrik 8-pin Speakon® connectors are used for electrical connection to the Xb loudspeakers with the following pin assignments:

LF1:	Pins 2 Paralleled
LF2:	Pins 1 Paralleled

The Xb wiring diagram is shown in Figure 7. Since the connectors are paralleled, it does not matter which connector is used as the input or output when paralleling Xb systems. Although Pins 3 and 4 are not used by the Xb systems, they are paralleled on the input panel. This allows an X-Array™ MB/HF box (like the Xf – which uses Pins 3 and 4, but not Pins 1 and 2) to be paral-

Xb Bass System

leled with an Xb, allowing all eight conductors to be used with a single cable run to the amplifiers. Note that, when two Xb systems are jumped from one to another via the input/output connections, the amplifier home run cable will have two LF drivers on Pins 2 (for a 4-ohm load) and two LF drivers on Pins 1 (for a 4-ohm load).

Flying the X-Array™ Systems

The X-Array™ loudspeaker systems all utilize the same rigging hardware and have the same structural strength ratings. Thus, different systems may be mixed in an array to achieve the best acoustic results. The rigging system allows for the smallest possible spacing between adjacent enclosures, and utilizes quick-release rigging fittings for fast installation and tear down.

When flown, the X-Array™ enclosures are linked together by two removable hinges on the rear of the enclosures at the top and bottom. This arrangement enables the enclosures to pivot vertically from the rear corners. The relative vertical angles between adjacent enclosures is adjustable and set by two removable rigging straps on the front of the enclosures at the top and bottom. Both the rear rigging hinges and the front rigging straps are installed when enclosures are sitting on top of one another. For ease of installation of the hinges and straps, the enclosures self align using feet and cups mounted on the top and bottom of the enclosures. The relative horizontal angle between adjacent columns of loudspeakers is set by adjustable grids at the top of the array (or by custom-building attachment supports in permanent-installation applications where grids are not used).

The removable proprietary rear rigging hinges utilize all-steel construction, and are secured into a proprietary track assembly on the enclosure (similar to the heavy-duty aircraft L-track). The aluminum track is extruded as a single-piece track/angle-bracket aluminum assembly and ties into the top, bottom and rear of the enclosure. Metal bars inside the enclosure tie the top and bottom track/angle-bracket assemblies together, minimizing the load applied to the wooden enclosure. The rear extrusion will accommodate the New Haven 32102-2 aircraft-type

double-stud locking fitting instead of the hinge for applications requiring a lower strength rating.

The removable, front strap assemblies utilize all-steel standard New Haven 32102-2 aircraft-type double-stud locking fittings and wire-rope and are secured into another proprietary track similar to the heavy-duty aircraft L-track. The track is extruded as a single-piece track/angle-bracket assembly that ties into the front and side of the enclosure. The track/angle-bracket assembly extends from the top to the bottom of the enclosure, eliminating the load applied to the wooden enclosure.

A complete line of flying-hardware accessories is available for the X-Array™ loudspeaker systems including a grid, rigging hinges and rigging straps. The variety of rigging hinges and front rigging straps available include those for linking two enclosures together, securing the top enclosure in a column to a and for picking up the top enclosure in a column without a grid. Consult the *X-Array™ Accessories* section for a complete listing of the available rigging accessories. The total weight of a column of X-Array™ loudspeaker systems that may be supported by the X-Array™ rigging system varies from 454-726 kg (1,000-1,600 lb) depending on the rigging configuration details. An X-Array™ *Flying Manual* is available from Electro-Voice and is included with each X-Array™ system shipment. The manual should be consulted for complete structural specifications and detailed instructions for safely suspending and using the X-Array™ systems.

Field Replacement

Normal service for the Xb requires only a #2 Phillips screwdriver and a 3/16-inch hex-key wrench. The drivers may be accessed as follows:

LF: First remove the grille, then remove the screws securing the hatch on the front of the enclosure. Remove the screws securing the 18-inch woofer and lift the driver out of the enclosure. In the event of failure, the entire woofer must be replaced.

The following service parts are available from the service department in Buchanan, Michigan USA:

LF #818-2883 EVX-180B complete driver

Architects' and Engineers' Specifications

The loudspeaker system shall be a two-driver, manifolded, vented-box low-frequency system with a frequency response from 37-160 Hz. The loudspeaker system also shall have two 457-mm (18-in.) low-frequency woofers and each shall have an 8-ohm, 101-mm (4-in.) diameter voice coil and a 600-watt power rating. The loudspeaker shall have a rigging system enabling a column of loudspeakers to be hinged at their back corners, with relative downward angles set by adjustable rigging straps at the front. The enclosure shall be constructed of 18-mm thick, 13-ply birch plywood, and shall be trapezoidal, forming an 18° wedge and be 914 mm (36.00 in.) high, 584 mm (23.00 in.) wide at the front, 365 mm (14.38 in.) wide at the back and 759 mm (29.88 in.) deep, and shall weigh 83 kg (184 lb).

Rigging Accessories:

Grid: This ATM Fly-Ware™ “T”-shaped, all-steel-construction grid was specifically designed as a single column of X-Array™ systems. Multiple grids can be linked together with couplers on front and back retractable arms, the position of which sets the splay angle between adjacent columns. Part number MEGS-4000-T. ATM Fly-ware™, 2100 S. Wilmington Ave., Carson, CA 90810 USA, 310/834-5914

Xrhg Grid Hinge: Two Xrhg grid rigging hinges are used to attach the rear of the top enclosure in a column to the rear of an X-Array™ compatible grid. Each hinge consists of two precision-machined steel rigging-track fittings connected by an alloy-steel chain. Part number 510-2999. Electro-Voice, 600 Cecil St., Buchanan, MI 49107 USA, 616/695-6831 or 800/234-6831

Xrhp Pickup Hinge: Two Xrhp pickup rigging hinges are used to create custom rigging assemblies to attach to the rear of the top enclosure in a column when an ATM grid is not used. Each hinge consists of one precision-machined steel rigging-track fitting with an alloy-steel chain. Part number 510-3000. Electro-Voice, 600 Cecil St., Buchanan, MI 49107 USA, 616/695-6831 or 800/234-6831

Xrhl Linking Hinge: Two Xrhl linking rigging hinges are used to link two enclosures together at the rear. Each hinge consists of two precision-machined steel rigging-track fittings connected by a heavy-duty steel hinge. Part number 510-2998. Electro-Voice, 600 Cecil St., Buchanan, MI 49107 USA, 616/695-6831 or 800/234-6831

Xrsl Long Rigging Steel Straps: Two Xrsl long rigging straps are used at the front of two enclosures to adjust their relative vertical angles. The Xrsl may also be used to attach the front of the top enclosure to the ATM grid when upward angles are not required. Each all-steel strap consists of two New Haven NH32102-2 double-stud fittings connected by black plastic-coated wire rope. Sound Manufacturing Inc., 3336 Primera Ave., Hollywood, CA 90068 USA, 213/850-5042 or ATM Fly-ware™, 2100 S. Wilmington Ave., Carson, CA 90810 USA, 310/834-5914

Xrss Short Rigging Steel Straps: Two Xrss short rigging straps are used to attach the front of the top enclosure to the ATM grid. The Xrss may also be used at the front of two enclosures when a limited range of vertical angles are required. The all-steel Xrss utilizes the same construction as the Xrsl. Sound Manufacturing Inc., 3336 Primera Ave., Hollywood, CA 90068 USA, 213/850-5042 or ATM Fly-ware™, 2100 S. Wilmington Ave., Carson, CA 90810 USA, 310/834-5914

General Rigging Supplies: A wide variety of standard and specialty rigging hardware components for both touring and permanent-installation applications is available. Sound Manufacturing Inc., 3336 Primera Ave., Hollywood, CA 90068 USA, 213/850-5042 or ATM Fly-ware™, 2100 S. Wilmington Ave., Carson, CA 90810 USA, 310/834-5914

Electronic Accessories:

Klark Teknik DN8000 Digital Controller: The DN8000 digital electronic loudspeaker controller has a two-in/five-out architecture, with each output having programmable high-pass and low-pass filters, four-band equalization, signal delay, compressor-limiter-and noise-gate functions. Program parameters for optimal performance of the X-Array™ sys-

tems are available. Klark Teknik, Klark Industrial Park, Walter Nash Road, Kidderminster, Worcestershire DY11 7HJ England, 44-156-274-1515

Electro-Voice Dx38 Digital Controller: The Dx38 digital electronic loudspeaker controller has a two-in/four-out architecture, with each output having programmable high-pass and low-pass filters, four-band equalization, signal delay compressor and limiter functions. Program parameters for optimal performance of the X-Array™ systems are available. Electro-Voice, 600 Cecil St., Buchanan, MI 49107 USA, 616/695-6831

Electro-Voice P3000 Power Amplifiers: The stereo P3000 power amplifiers are rated at 800 watts into 8 ohms, or 93-volts rms short term. The amplifiers are 3-U high and weigh 28 kg (62 lb) each. EVI Audio, 600 Cecil St., Buchanan, MI 49107 USA, 616/695-6831

X-Array™ Amplifier Racks: These 22-U racks will hold six Electro-Voice P3000 power amplifiers, one Klark Teknik DN8000 digital controller, 1-U light module, and a 2-U multipin patch panel. The aluminum-frame/wood-panel racks are vibration-isolation mounted on heavy-duty wheel boards and come prewired for AC power, audio and control signal sends and Neutrik® Speakon speaker connectors. db Sound, L.P., 1219 Rand Road, Des Plaines, IL 60016 USA, 847/299-0357

X-Array™ Speaker Cables: Eight conductor cable with four #11 AWG conductors and four #13 AWG connectors. The larger conductors are used in the LF bands for increased damping factor. Lengths made to order. Standard terminations are Neutrik Speakon™ NL8FC connectors wired to X-Array™ standards; however, custom terminations are available. Entertainment Technology Cable, 1247 Rand Road, Des Plaines, IL 60016 USA, 800/529-6312

Miscellaneous Accessories:

X-Array™ Loudspeaker Covers: Heavy-duty covers are available for the X-Array™ speakers. These covers wrap around the enclosures, while sitting on a dolly, and Velcro together at the back for fast installation and removal. db Sound, L.P., 1219 Rand Road, Des Plaines, IL 60016 USA, 847/299-0357

X-Array™ Dolly Boards: Double-wide dolly built to hold four X-Array™ loudspeakers, two wide by two high. The double-thick 18-mm birch-plywood construction includes cutouts and keys for loudspeaker enclosure shape and alignment feet. The dolly boards are painted black and utilize four extra-heavy-duty 4-inch x 2-inch casters. Custom-designed dolly boards are also available to meet specific requirements. R&R Cases and Cabinets, 1217 Rand Road, Des Plaines, IL 60016 USA, 847/299-8100

Racks and Road Cases: A variety of general purpose, custom racks and hard-shell road cases are available for touring or permanent-installation applications. R&R Cases and Cabinets, 1217 Rand Road, Des Plaines, IL 60016 USA, 847/299-8100

Uniform Limited Warranty

Electro-Voice products are guaranteed against malfunction due to defects in materials or workmanship for a specified period, as noted in the individual product-line statement(s) below, or in the individual product data sheet or owner's manual, beginning with the date of original purchase. If such malfunction occurs during the specified period, the product will be repaired or replaced (at our option) without charge. The product will be returned to the customer prepaid. Exclusions and Limitations: The Limited Warranty does not apply to: (a) exterior finish or appearance; (b) certain specific items described in the individual product-line statement(s) below, or in the individual product data sheet or owner's manual; (c) malfunction resulting from use or operation of the product other than as specified in the product data sheet or owner's manual; (d) malfunction resulting from misuse or abuse of the product; or (e) malfunction occurring at any time after repairs have been made to the product by anyone other than Electro-Voice Service or any of its authorized service representatives. Obtaining Warranty Service: To obtain warranty service, a customer must deliver the product, prepaid, to Electro-Voice Service or any of its authorized service representatives together with proof of purchase of the product in the form of a bill of sale or receipted invoice. A list of

Xb Bass System

authorized service representatives is available from Electro-Voice Service at 600 Cecil Street, Buchanan, MI 49107 (800-234-6831 or FAX 616-695-4743). **Incidental and Consequential Damages Excluded:** Product repair or replacement and return to the customer are the only remedies provided to the customer. Electro-Voice shall not be liable for any incidental or consequential damages including, without limitation, injury to persons or property or loss of use. Some states do not allow the exclusion or limitation of incidental or consequential damages so the above limitation or exclusion may not apply to you. **Other Rights:** This warranty gives you specific legal rights, and you may also have other rights which vary from state to state.

Electro-Voice Speakers and Speaker Systems are guaranteed against malfunction due to defects in materials or workmanship for a period of five (5) years from the date of original purchase. The Limited Warranty does not apply to burned voice coils or malfunctions such as cone and/or coil damage resulting from improperly designed enclosures. Electro-Voice active electronics associated with the speaker systems are guaranteed for three (3) years from the date of original purchase. Additional details are included in the Uniform Limited Warranty statement. **Electro-Voice Accessories** are guaranteed against malfunction due to defects in materials or workmanship for a period of one (1)

year from the date of original purchase. Additional details are included in the Uniform Limited Warranty statement.

Electro-Voice Flying Hardware (including enclosure-mounted hardware and rigging accessories) is guaranteed against malfunction due to defects in materials or workmanship for a period of one (1) year from the date of original purchase. Additional details are included in the Uniform Limited Warranty statement.

For warranty repair, service information, or a listing of the repair facilities nearest you, contact the service repair department at: 616/695-6831 or 800/685-2606.

For technical assistance, call: 800/234-6831. Specifications subject to change without notice.

Figure 1 — Polar Response

The directional response of the Xb was measured in an anechoic environment at a distance of 6.1 m (20 ft.) using 1/3-octave-filtered pink noise with a full spherical measurement system. The polar response of the loudspeaker system at selected 1/3-octave frequencies is shown. The selected frequencies are representative of the polar response of the system.

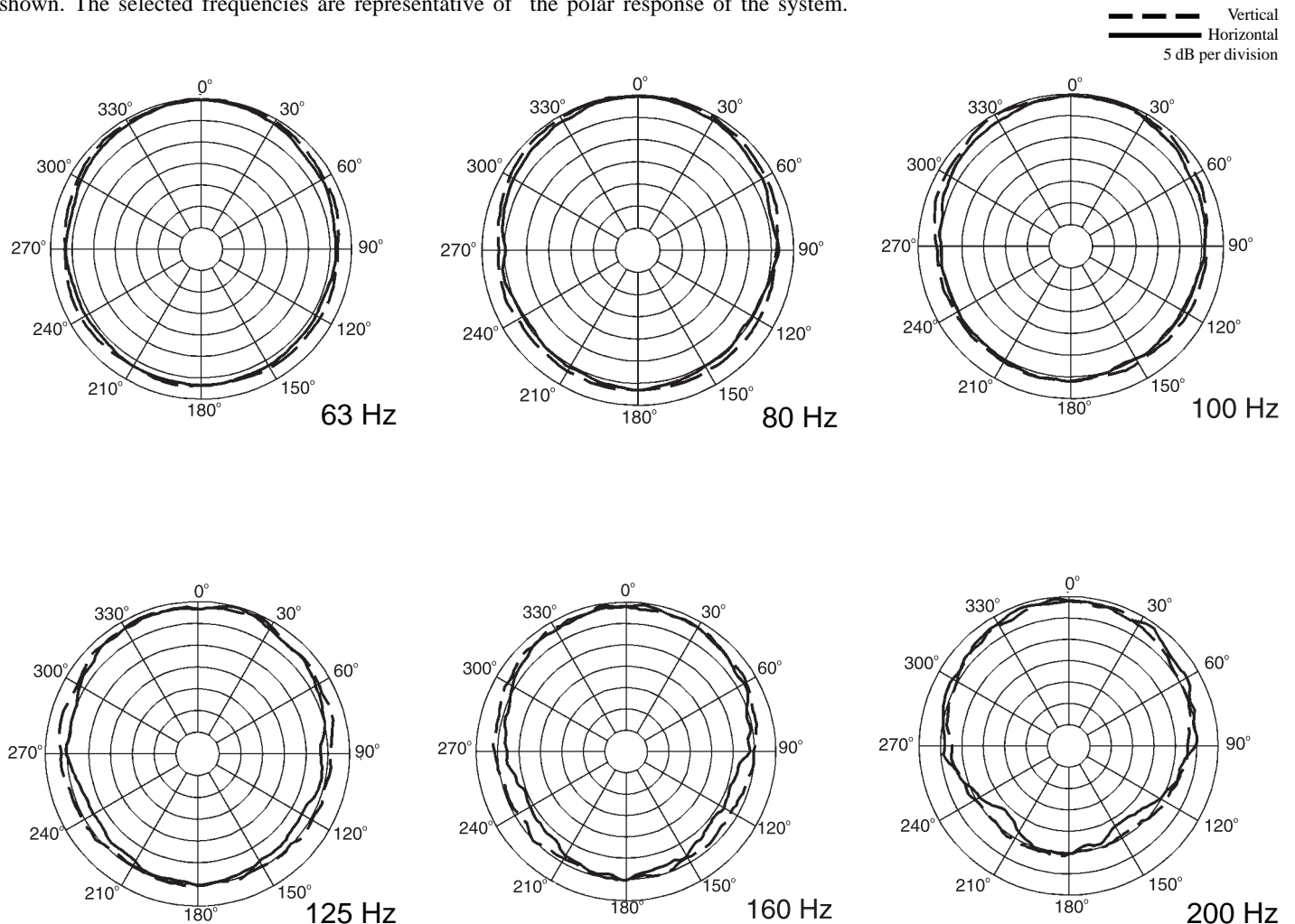

Xb Bass System

Figure 2 — Frequency Response

The frequency response of the Xb was measured on axis in the far field in an anechoic environment using a swept sine-wave signal. The Klark Teknik DN8000 digital electronic unit was used to provide the necessary crossover filters, equalization and time delay. One watt of power (2.00-volts rms at 70 Hz) was applied to the mid band of the low-frequency section. The sound pressure level was normalized for an equivalent one- meter distance.

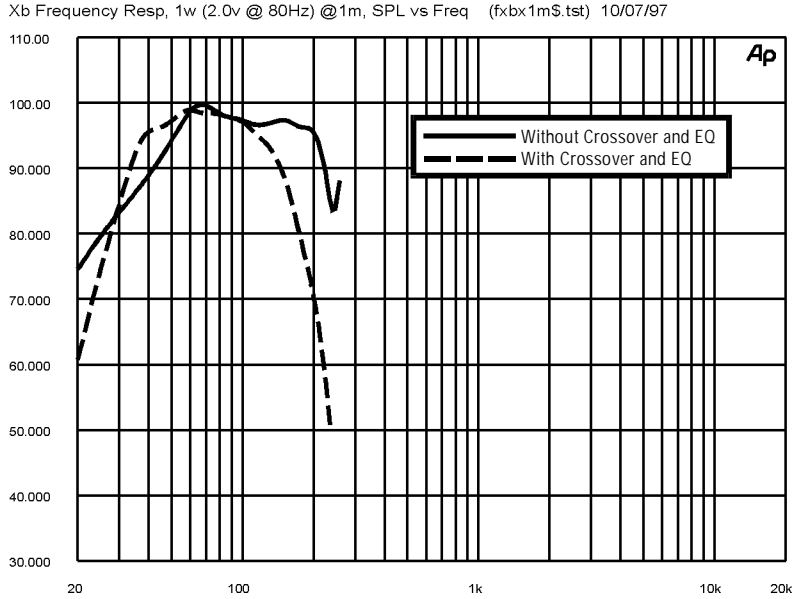

Figure 3 — Beamwidth

The beamwidth of the Xb, (i.e., the included horizontal and vertical coverage angles at the -6-dB points) was measured with a full-spherical measurement system as described in Figure 1.

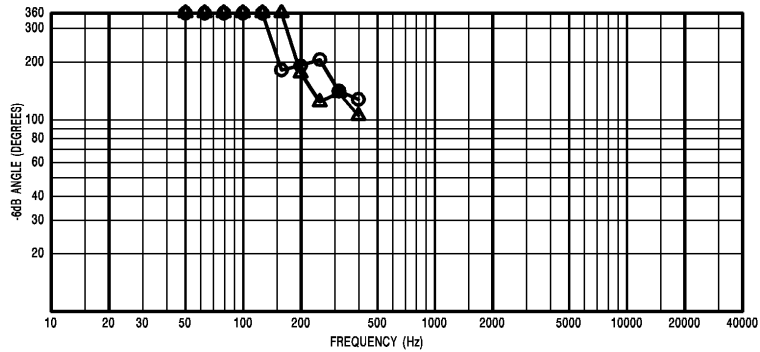
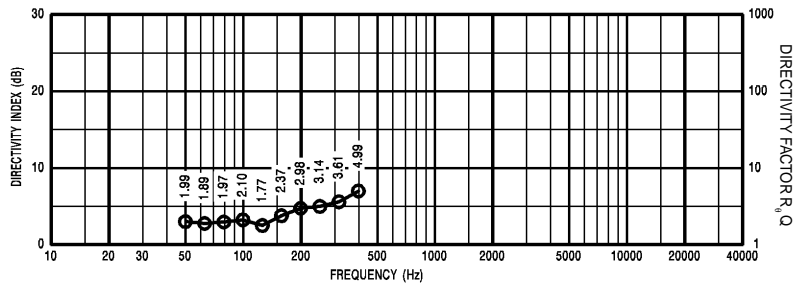

Figure 4 — Directivity

The directivity index, D_i , and directivity factor, R , of the Xb were measured with a full-spherical measurement system as described in Figure 1.



Xb Bass System

Figure 5 — Distortion

Distortion for the Xb was measured on axis in the far field in an anechoic environment with an input signal that would result in a sound pressure level of 115 dB at one meter. The Klark Teknik DN8000 digital electronic unit was used to provide the necessary crossover filters, equalization and time delay. The sound pressure level was normalized for an equivalent one-meter distance. Plots of second and third harmonic distortion are shown referenced to the fundamental.

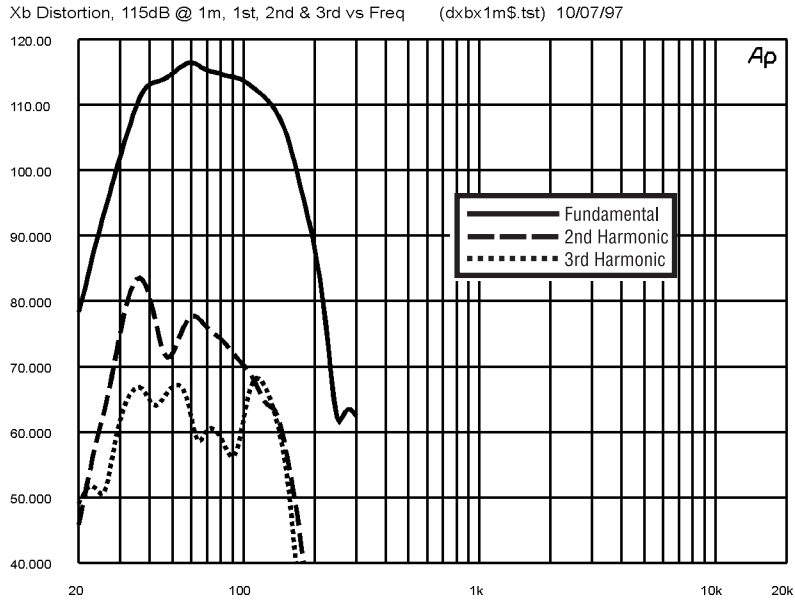

Figure 6 — Impedance

The impedance of each frequency band of the Xb was measured in an anechoic environment

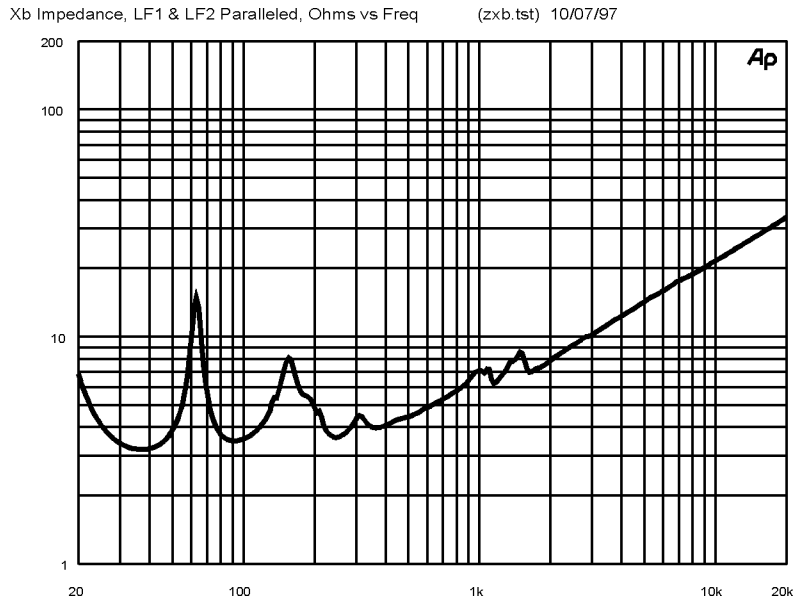
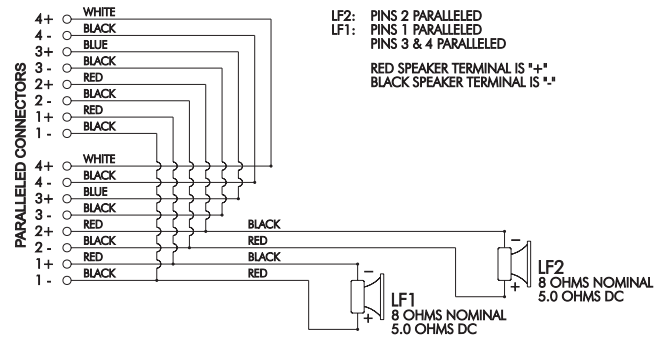

Figure 7 — Wiring Diagram

The wiring diagram of each frequency band of the Xb is shown.



Xb Bass System

Figure 8—Dimensions

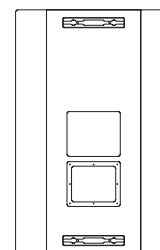
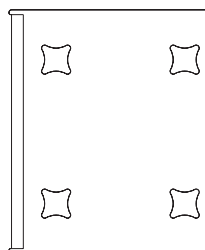
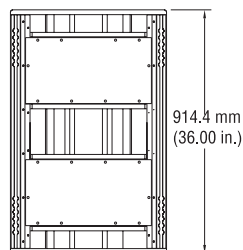
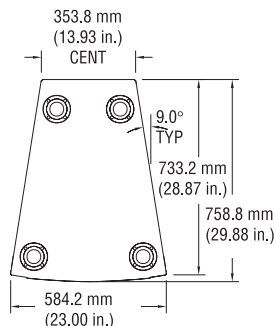

Specifications

Frequency Response (measured in far field, with and without crossover and equalization, calculated to one meter on axis, swept sine wave, one watt into system - 2.00 V at 70 Hz, anechoic environment; see Figure 2):

37-200 Hz

Crossover Frequency:

125 Hz

Efficiency Mid Band:

5.3 %

Maximum Long-Term-Average Power-Handling Capacity (per ANSI/EIA RS-426A 1980):

1,200 watts

Maximum Long-Term-Average Mid-Band Acoustic Output, LF/HF:

64 acoustic watts

Sensitivity (SPL at one meter, indicated input power, anechoic environment, average level),

1 watt:

98.5 dB

1,200 watts:

129.3 dB

Beamwidth (angle included by 6-dB-down points on polar responses, indicated one-third-octave bands of pink noise; see Figures 1 and 3),

Horizontal, 63-200 Hz:

240° (+120°, -60°)

Vertical, 63-200 Hz:

300° (+60°, -120°)

Directivity Factor, R (Q), 63-200 Hz

Average (see Figure 4):

2.2 (+0.8, -0.4)

Directivity Index, D_i, 63-200 Hz

Average (see Figure 4):

3.4 dB (+1.4 dB, -0.9 dB)

Distortion (115 dB SPL at one meter, shaped spectrum; see Figure 5),

Second Harmonic,

40 Hz:

2.2%

80 Hz:

0.9 %

Third Harmonic,

40 Hz:

0.4 %

80 Hz:

0.2 %

Transducer Complement,

Two EVX-180B 18-in. woofers

Impedance (see Figure 6),

Nominal:

Two 8-ohm loads

Minimum:

Two 6.4-ohm loads

Input Connections:

Two Neutrik NL8MPR Speakon® connectors paralleled

Recommended Amplifier Power, Rating:

800 watts per channel @ 8 ohms

(93-volts rms short term)

Enclosure Construction,

Enclosure Shell:

18-mm, 13-ply birch plywood

Finish:

Black textured paint

Grille:

Powder-coated steel with foam

Rigging: EV Proprietary hinge system at rear. Heavy-duty L-track on front which accepts New Haven NH32102-2 double-stud fittings

Dimensions,

Height:

914.4 mm (36.00 in.)

Width (front):

584.2 mm (23.00 in.)

Width (back):

353.8 mm (13.93 in.)

Depth:

758.8 mm (29.88 in.)

Angle:

18° wedge

Net Weight:

83.5 kg (184 lb)

Shipping Weight:

87.5 kg (193 lb)

Electro-Voice®

600 Cecil Street, Buchanan, MI 49107

616/695-6831, 616/695-1304 Fax

©Telex Communications, Inc., 1999 • Litho in U.S.A.

SPEAKERS—X-Array™

Part Number 534636 Rev. B—9934