

TS940S

Theatre Stage System

Electro-Voice

Theatre Sound System®

Atec Lansing

Voice of the Theatre®

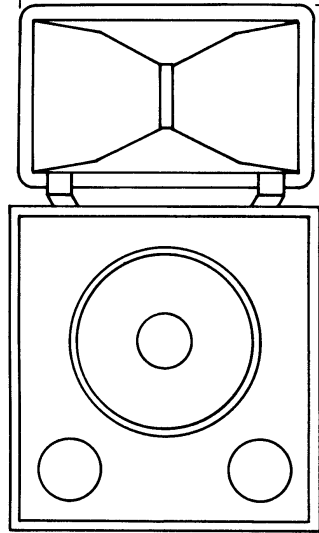

Description

In the TS940S, Electro-Voice has combined its expertise in constant-directivity horns, high-frequency compression drivers and low-frequency speakers and enclosures to produce a compact, easily installed theatre stage system with superior performance in all areas: uniform dispersion to the highest frequencies, high efficiency, high power capacity and wide, smooth frequency response, all in a small, compact system.

The TS940S matches the only second-generation constant-directivity high-frequency to a world class high-frequency driver, providing accurate reproduction and coverage of frequency from 500 Hz to 20,000 Hz. Electro-Voice invented constant-directivity technology, first introduced in our HR series horns in 1974. The HP horn in the TS940S is a significant refinement. Constant directivity means that all frequencies are evenly spread over the horn's rated coverage angle, so every seat in the house can receive both clear dialogue and subtle high-frequency effects. For low-frequencies, a single 15-inch woofer is used in an optimally vented radiating enclosure. The high-excursion

woofer is, mounted in an optimally vented, Thiele-Small enclosure, provide high-impact bass from 40 through 800 Hz, at average powers up to 800 watts, when required. In the field, the TS940S's combination of high- and low-frequency reproduction has proven to be an excellent choice for small to medium size houses.

The TS940S incorporates a number of installer-recommended features, for quick, trouble-free and low-cost installations. Among these features is a dedicated crossover/equalizer that is easily flush mounted in the pre-sized, pre-drilled hole located on the side of the low-frequency enclosure. Side mounting provides easy wiring access when the system is installed against a wall. Through the use of the horn mounting kit and pre-drilled holes in the low-frequency section is easily mounted in the proper position on top of the low-frequency enclosure. All pre-drilled holes are T-nut loaded, including the bass driver mounting holes. This means quick and easy driver replacement. All components of the TS940S are finished in matte black, to eliminate any reflections back through the screen.

Limited Warranty

Electro-Voice products are guaranteed against malfunction due to defects in materials or workmanship for a specified period, as noted in the individual product-line statement(s) below, or in the individual product data sheet or owner's manual, beginning with the date of original purchase. If such malfunction occurs during the specified period, the product will be repaired or replaced (at our option) without charge. The product will be returned to the customer prepaid. **Exclusions and Limitations:** The Limited Warranty does not apply to: (a) exterior finish or appearance; (b) certain specific items described in the individual product-line statement(s) below, or in the individual product data sheet or owner's manual; (c) malfunction resulting from use or operation of the product other than as specified in the product data sheet or owner's manual; (d) malfunction resulting from misuse or abuse of the product; or (e) malfunction occurring at any time after repairs have been made to

TS940S Theatre Stage System

TS940S Theatre Stage System

the product by anyone other than Electro-Voice Service or any of its authorized service representatives. **Obtaining Warranty Service:** To obtain warranty service, a customer must deliver the product, prepaid, to Electro-Voice Service or any of its authorized service representatives together with proof of purchase of the product in the form of a bill of sale or receipted invoice. A list of authorized service representatives is available from Electro-Voice Service at 600 Cecil Street, Buchanan, MI 49107 (800/234-6831 or FAX

616/695-4743). **Incidental and Consequential Damages Excluded:** Product repair or replacement and return to the customer are the only remedies provided to the customer. Electro-Voice shall not be liable for any incidental or consequential damages including, without limitation, injury to persons or property or loss of use. Some states do not allow the exclusion or limitation of incidental or consequential damages so the above limitation or exclusion may not apply to you. **Other Rights:** This warranty gives

you specific legal rights, and you may also have other rights which vary from state to state.

For warranty repair or service information, contact the service repair department at: 616/695-6831 or 800/685-2606.

For technical assistance, contact Technical Support at 800/234-6831 or 616/695-6831, M-F, 8:00 a.m. to 5:00 p.m. Eastern Time. Specifications subject to change without notice.

TS940S Theatre Stage System

Figure 1—Dimensions

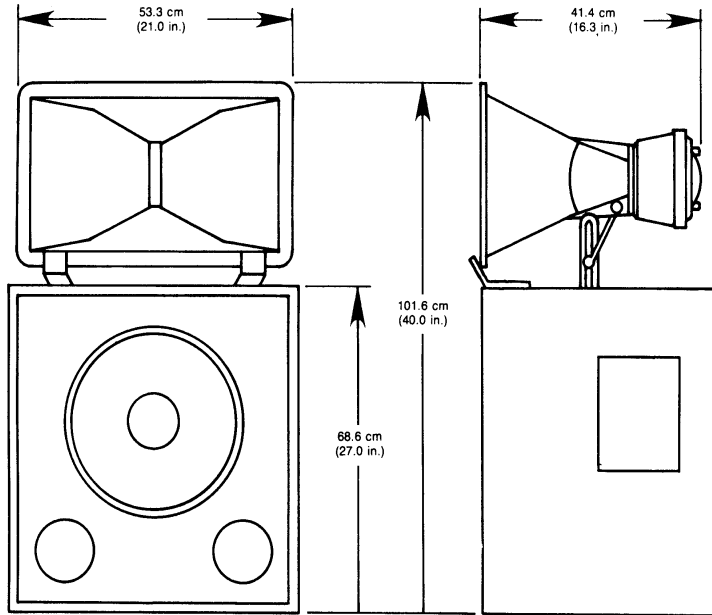

TS940S Theatre Stage System

Figure 2—Frequency response
4 Volts/20 Feet

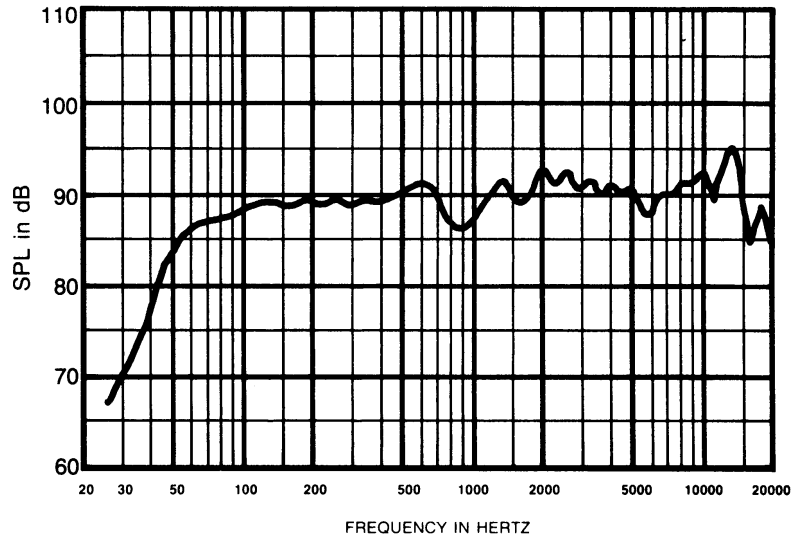

TS940S Theatre Stage System

TS940S Theatre Stage System

Specifications**

Usable Frequency Response:

45-20,000 Hz

Sound Pressure Level at 1 Watt, 1 Meter

100 dB

Power Capacity Per EIA Standard**RS-426A,****Long-Term Average:**

100 watts

Short-Term Peak:

400 watts

Crossover Frequency:

800 Hz

Dispersion,**Horizontal:**

90

Vertical:

40

Nominal Impedance:

8 ohms

Components:

DH1A: High-frequency driver

HP940T: High-frequency theatre horn

HMK-1: Horn mounting kit

XEQ-808: Crossover/equalizer

TL606AXT: Low-frequency system

Dimensions (see Figure1),**Height :**

101.6 cm (40.0 in.)

Width:

53.3 cm (21.0 in.)

Depth:

41.4 cm (16.3 in.)

Finish:

Matte black

Net Weight:

42.4 kg (93.4 lb)

Shipping Weight:

46.9 kg (103.5 lb)

Electro-Voice®

600 Cecil Street, Buchanan, MI 49107

616/695-6831, 616/695-1304 Fax

Manufacturing Plants at,

Buchanan, MI • Newport, TN • Sevierville, TN • Austin, TX

©Telex Communications, Inc. 1998 • Litho in U.S.A.

Part Number 531095-9821