



Electro-Voice
Theatre Sound System*

TS9040D

Theatre
Stage System

SPECIFICATIONS¹

Usable Frequency Response:

30-20,000 Hz

Sound Pressure Level at 1 Meter,

1 Watt Input:

100 dB

Power Capacity Per EIA Standard

RS-426A,

Long-Term Average:

300 watts

Short-Term Peak:

1,200 watts

Crossover Frequency:

500 Hz

Dispersion,

Horizontal:

90°

Vertical:

40°

Nominal Impedance:

8 ohms

Components,

DH1A: high-frequency driver

HP9040T: high-frequency theatre horn

HMK-2: horn mounting kit

XEQ-504: crossover/equalizer

TL606DW: low-frequency system

Dimensions (see Figure 1):

181.6 cm (71.5 in.) high

68.1 cm (26.8 in.) wide

94.7 cm (37.3 in.) deep

Finish:

Matte black

Net Weight:

74.8 kg (165 lb)

Shipping Weight:

87.1 kg (192 lb)

1. Additional information can be found on individual component engineering data sheets.

DESCRIPTION AND APPLICATION

In the TS9040D, Electro-Voice has combined its expertise in large-format constant-directivity horns, high-frequency compression drivers and low-frequency speakers and enclosures to produce a compact, easily installed theatre stage system with superior performance in all areas: uniform dispersion to the highest frequencies, high efficiency, high power handling capacity and wide, smooth frequency response.

The TS9040D matches the only second-generation, large-format, constant-directivity high-frequency horn to a world-class high-frequency driver, providing accurate reproduction and coverage of frequencies from 500 Hz to 20,000 Hz. Electro-Voice invented constant-directivity technology, first introduced in our HR series horns in 1974. The large-format HP horn in the TS9040D is a significant refinement. "Constant directivity" means that all frequencies are evenly spread over the horn's rated coverage angle, so that every seat in the house can receive both clear dialogue and subtle high-frequency effects. For low frequencies, two 15-inch woofers are vertically stacked in a direct-radiating configuration, providing a coverage pattern that closely matches that of the high-frequency horn in the crossover region. Such a match is not possible with more traditional horn-loaded bass enclosures. The high-excursion woofers, mounted in an optimally vented Thiele-Small enclosure, provide high-impact bass from 40-500 Hz, at average powers up to 800 watts, when

required. In the field, the TS9040D's combination of high- and low-frequency reproduction has proven to be an excellent choice for houses of medium-to-large size.

The TS9040D incorporates a number of installer-recommended features, for quick, trouble-free and low-cost installation. Among these features is a dedicated crossover/equalizer that is easily flush mounted in the pre-sized, pre-drilled hole located in the side of the low-frequency enclosure. Side mounting provides easy wiring access when the system is installed against a wall. Through the use of the horn-mounting kit and pre-drilled holes in the low-frequency system, the high-frequency section is easily mounted in the proper position on top of the low-frequency section. All pre-drilled holes are T-nut loaded, including bass driver mounting holes. This means quick and easy driver replacement. All components of the TS9040D are finished in matte black, to eliminate any reflections back through the screen.

FREQUENCY RESPONSE

The data was measured in an anechoic (echoless) environment at 20 feet on axis with 4 volts of swept 1/3-octave random noise. The frequency response curve for the TS9040D is shown in Figure 2.

WARRANTY (Limited)

Electro-Voice Theatre Sound Systems are guaranteed for five years from date of original purchase against malfunction due to defects in workmanship and materials. If such malfunction occurs, unit will be repaired or replaced (at our option) without charge for materials or labor if delivered prepaid to the proper Electro-Voice service facility. Unit will be returned prepaid. Warranty does not cover finish or appearance items or malfunction due to abuse or operation at other than specified conditions. Repair by other than Electro-Voice or its authorized service agencies will void this guarantee.

For repair information and service locations, please write: Service Department, Electro-Voice, Inc., 600 Cecil Street, Buchanan, Michigan 49107 (Phone 616/695-6831) or Electro-Voice, Inc., 3810 148th Avenue N.E., Redmond, WA 98052 (Phone 206/881-9555) or Electro-Voice West, 8234 Doe Avenue, Visalia, CA 93291 (Phone 209/651-7777). This warranty gives you specific legal rights, and you may also have other rights which vary from state to state.

Specifications subject to change without notice.

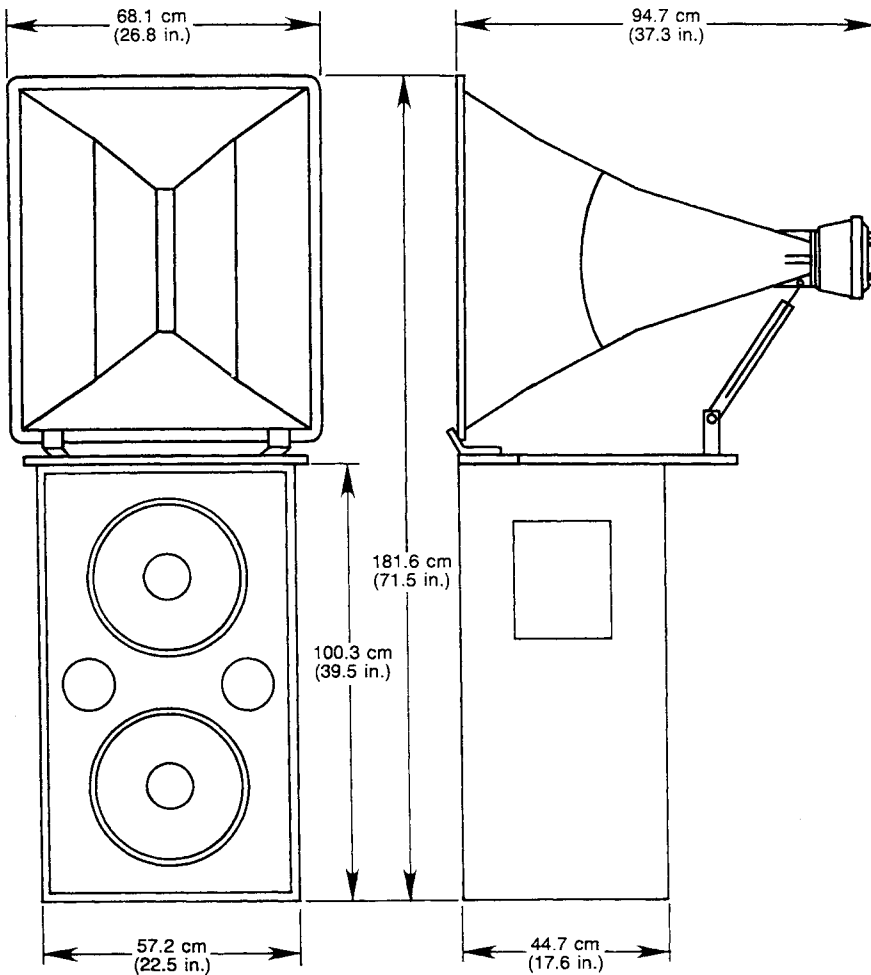

FIGURE 1
TS9040D Dimensions

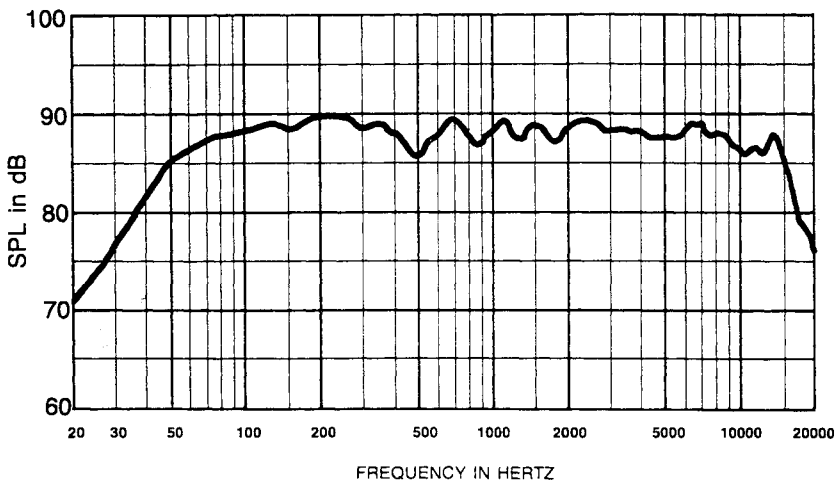

FIGURE 2
TS9040D Frequency Response



ELECTRO-VOICE, INC., 600 Cecil Street, Buchanan, Michigan 49107

MANUFACTURING PLANTS AT ■ BUCHANAN, MI ■ NEWPORT, TN ■ SEVIERVILLE, TN ■ REDMOND, WA ■ GANANOQUE, ONT.
©Electro-Voice, Inc. 1987 ■ Litho In U.S.A. Part Number 530773-727