

TL606DMT

Low-Frequency Speaker System

- High efficiency and low distortion
- 2 DL15MT woofers for increased longevity under extreme power conditions
- Versatile system design capabilities

Description

The Electro-Voice TL606DMT is an optimally vented, direct-radiator speaker system for high-output reproduction of low frequency to 40 Hz. The TL606DMT's design based on the vented-enclosure modeling technique of A.N. Thiele and R.H. Small, which makes possible a combination of high efficiency, low-distortion and extended low-frequency performance in an enclosure of moderate size.

The TL606DMT employs dual DL15MT very-low-frequency reproducers in a 9-cubic-foot (255 liter) enclosure. The DL15MT's high linear cone-excursion ability ($X_{\max} = 0.22$ inches, zero to peak) and 400-watt long-term average power capacity contribute substantially to the TL606DMT's high acoustic output ability (see Power Handling Capacity section).

Applications

The TL606DMT was specifically designed for use with the Variplex cinema three-way. It's high excursion, low distortion and longevity under extreme power conditions make it an intricate component for producing the dynamic clarity of the Variplex System. The

TL606DMT is also ideally configured for a wide variety of high-output, low-frequency reinforcement applications in permanently installed sound systems. Typical venues include cinemas, auditoriums, theaters, performing arts centers, night clubs and concert halls. The TL606DMT is designed to serve as the primary low-frequency section in extended-response two-way systems with excellent bass performance to 40 Hz and controlled dispersion to 800 Hz—a typical crossover frequency of two-way systems. When used with the dedicated XEQ-504 crossover/equalizer, the TL606DMT can be combined with appropriate Electro-Voice TransPlanar™ horns and DH series drivers to form a passive two-way system of unprecedented wide-range response and linearity. However, to extract the maximum performance from the TL606DMT, a multiamp configuration using the XEQ-2 or XEQ-3 crossover/equalizer units is recommended so that full rated power may be applied to the low-frequency system. With a half-power point of 40 Hz, the TL606DMT can also serve as the subwoofer component in large, multiway systems.

Frequency Response

The TL606DMT frequency response was measured in an anechoic environment at 10 feet on axis with swept one-third-octave pink noise. The frequency response curve for the TL606DMT are shown in Figure 1.

Directivity

The TL606DMT directional characteristics were measured by running a set of polar-response curves in EV's large, anechoic chamber. The test signal was one-third-octave pseudo-random pink noise centered at the frequencies indicated in Figure 2. The curves show horizontal (side-to-side) dispersion when the enclosure's long axis is vertical. The vertical (up-and-down) polar responses are also shown.

Additional typical information is provided in Figure 3 which shows 6-dB-down beamwidth versus frequency. Figure 4 shows the directivity factor and directivity index versus frequency.

Distortion

Following AES (Audio Engineering Society) recommended practice, plots of second- and third-order harmonic distortion for 0.1 rated input power are shown in Figure 5.

TL606DMT Low-Frequency Speaker System

Power Handling Capacity

To our knowledge, Electro-Voice was the first U.S. manufacturer to develop and publish a power test closely related to real-life conditions. First, we use a random noise input signal because it contains many frequencies simultaneously, just like real voice or instrument program. Second, our signal contains more energy at extremely high and low frequencies than typical actual program, adding an extra measure of reliability. Third, the test signal includes not only the overall “long-term average” or “continuous” level—which our ears interpret as loudness—but also short-duration peaks which are many times higher than the average, just like actual program. The long-term average level stresses the speaker thermally (heat). The instantaneous peaks test mechanical reliability (cone and diaphragm excursion). Note that the sine-wave test signals sometimes used have a much less demanding peak value relative to their average level. In actual use, long-term average levels exist from several seconds on up, but we apply the long-term average for several hours, adding another extra measure of reliability.

Specifically, the TL606DMT is designed to withstand the power test described in EIA Standard RS-426A. The EIA test spectrum is applied for eight hours. To obtain the spectrum, the output of a white noise generator (white noise is a particular type of random noise with equal energy per bandwidth in Hz) is fed to a shaping filter with 6-dB-per-octave slopes below 40 Hz and above 318 Hz. When measured with the usual constant-percentage analyzer (one-third-octave), this shaping filter produces a spectrum whose 3-dB-down points are at 100 Hz and 1,200 Hz with a 3-dB-per-octave slope above 1,200 Hz. This shaped signal is sent to the power amplifier with the continuous power set at 800 watts into the 3.5 ohms EIA equivalent impedance for the TL606DMT (52.9 volts true rms).

Amplifier clipping sets instantaneous peaks at 6 dB above the continuous power, or 3,200 watts peak (105 volts peak). This procedure provides a rigorous test of both thermal and mechanical failure modes.

Subpassband Speaker Protection

Below the enclosure tuning frequency, cone excursion increases rapidly. Since acoustic output is also failing rapidly, there is no utility in driving the system with signals much below the tuning frequency. While such signals may be in the program material, they are often extraneous—such as from record-surface irregularities (strong 5- to 25-Hz components) or a dropped microphone. The DL15MT very-low-frequency reproducer is ruggedly designed and has a high maximum excursion before damage (± 0.5 inch). However, high-output subwoofer systems such as the TL606DMT should be protected by a high-pass filter with a 3-dB-down corner frequency of about 0.8 the enclosure tuning frequency. Below the corner frequency, a roll-off of 12-dB-per-octave is usually sufficient. Without protection, subpassband signals may “bottom” the DL15MT’s. Damage will probably result, especially after repeated occurrences. Even if bottoming does not occur, the subpassband signals waste amplifier power and modulate (distort) the frequencies which are within the TL606DMT’s operating range. Much “woofer distortion” or “muddy bass” can be attributed to lack of subpassband protection.

The Electro-Voice EX-24, XEQ-2 and XEQ-3 electronic crossover/equalizers provide subpassband protection. The 3-dB-down points are 30 Hz (EX-24 and XEQ-2) and 16 Hz or 32 Hz (XEQ-3).

Other high-pass filters are available, and one-third-octave equalizers can also be effective at providing the required protection.

Use in Multiples

TL606DMT’s may be used in multiples to increase acoustic output. In the following discussion, it is assumed that all speaker cones are operating in unison (in phase) when a common signal is applied. A 6-dB increase in maximum acoustic output results when two speakers are located side by side. For operation at very low frequencies, the woofer cones “mutually couple,” acting as one speaker with cone area and power-handling capacity twice that of a single speaker. The doubling of cone area doubles efficiency,

providing a 3-dB increase in sound pressure level. The second 3 dB comes from the doubling of power capacity.

Mutual coupling occurs when the frequency is such that the center-to-center distance between the two speaker cones is less than about one-quarter wavelength. For a given center-to-center distance, the highest frequency at which mutual coupling will occur can be calculated from the following formula:

$$f = \frac{3,000}{D_{\max}}$$

where D_{\max} is the distance in inches and f is frequency in Hz. When D_{\max} is greater than one-quarter wavelength, as would occur if two TL606DMT’s were widely spaced, the level increase tends to be limited to the 3-dB power-handling increase.

More than two TL606DMT’s can be used for increased output. In general, maximum acoustic power output ability increases as the square of the number of mutually coupled cones. For example, four cones would provide 4^2 or 16 times the power output of a single cone, an increase of 12 dB ($10 \log_{10} 16 = 12$ dB). Note that the associated increased efficiency (2.9% $\times 4 = 12\%$) approaches that of a fully horn-loaded design, but in a much smaller enclosure.

System Positioning

Subwoofer systems such as the TL606DMT are often located on the floor. This is both convenient and can provide a desired high acoustic impact when the speakers are, for example, placed near the periphery of a dance floor. In other installations, such as a theater or auditorium, the audible location of a subwoofer operating at a sufficiently low crossover frequency (below about 125 Hz) will not be particularly evident. The other system elements operating above the subwoofer range can be positioned for the desired locational cues and uniform audience coverage.

Floor location provides the acoustic half-space environment associated with the 5.8% system efficiency noted in the Specifications section. Location at a floor-wall junction (acoustic quarter space) doubles efficiency

TL606DMT Low-Frequency Speaker System

(a 3-dB increase in sound pressure level) and tends to promote the full excitation of more room modes, or standing waves, important in achieving maximum overall bass output in the room. Corner placement (acoustic eighth space) doubles efficiency again and guarantees excitation of all room modes. (Such placement for maximum efficiency and room-mode excitation is not necessary and may not be desirable or possible for a variety of reasons, including aesthetics and building design.)

The TL606DMT can also be successfully operated away from any nearby acoustic boundaries, particularly when multiple systems are used for increased output ability (see Use in Multiples section).

Suspending TL606DMT Enclosures

The TL606DMT is designed for typical cinema stage (behind-the-screen) applications where low-frequency systems are mounted on platforms, behind the screen and some distance above the stage floor. **The TL606DMT is not designed to be self-suspended, and if suspended, must be supported and hung in a way which does not depend on the structure of the TL606DMT itself for support.**

The HS6 and HS7 kits allow the TL606DMT to be hung safely in a variety of orientations. The combination of the correct HS kits and TL606DMT enclosure has been certified by an independent structural engineer to be safe and secure. Each HS kit consists of a steel tube, two brackets, two eyebolts and the necessary fasteners. The installer must assemble the HS kit by first drilling two holes into the TL606DMT enclosure, in predefined positions, and then screwing the brackets onto the steel tube, which passes through the enclosure. An eyebolt is inserted in the T-nut in the rear panel of the enclosure to provide a "pull up" to aim the enclosure. Full instructions and hole locations are included with each cabinet and HS kit. A TL606DMT requires a single HS6 to suspend it horizontally, or a single HS7 to suspend it vertically. Electro-Voice recommends that only one TL606DMT be suspended at one time in this manner. Vertical is defined as having the long side vertical. **Full attention must be**

given to the instructions and limitations in the HS kit instruction sheet.

Accessories for Special Systems

The TL606DMT was designed to be used with Electro-Voice TransPlanar™ horns, DH series compression drivers and accessories to form passive, 500 Hz crossover systems that may be easily and quickly assembled and installed. A 500-Hz passive crossover, the XEQ-504, directly replaces the TL606DMT's input panel. Mounting kits, the HMK-1 and HMK-2, provide the necessary hardware and accessories to mount the HP940/DH1A and HP9040/DH1A horn/driver combinations, respectively, to the TL606DMT box. Steel threaded inserts are provided on the top panel of the box to accommodate mounting kits for both horn combinations.

Architects' and Engineers' Specifications

The loudspeaker system shall consist of two 380-mm (15-in.) very-low-frequency reproducers installed in a vented enclosure. The frame of the reproducer shall be manufactured of cast aluminum, and its magnetic assembly shall utilize a ferrite magnet. An aluminum ring mounted to the top of the pole piece shall act as a control on drive inductance and provide a heat-transfer path from the top of the voice coil. The inner surface of the top plate shall be coated with PROTEF™, a Teflon®-based coating used for prevention of damage to the voice coil.¹

Performance specifications of a typical production unit shall be as follows: measured sensitivity (SPL at 1 m on axis with 1 W input, swept 100-800 Hz) shall be at least 100 dB SPL; usable frequency range shall extend from 30 Hz to 3,500 Hz; nominal impedance shall be 4 ohms; rated power handling capacity shall be at least 800 watts, conforming to EIA standard RS-426A.

The enclosure shall be solidly constructed of 19-mm (3/4-in.) stock with all joints tightly fitted and glued. Overall dimensions shall be no greater than 100.3 cm (39.5 in.) high by 57.2 cm (22.5 in.) wide by 44.7 cm (17.6 in.) deep. Finish shall be black vinyl with leatherette pattern. An independently

certified suspension kit shall be available to suspend the TL606DMT horizontally (model HS6) or vertically (model HS7). Internal 1/4"-20 threaded fasteners provide a method of mounting high-frequency or mid-high devices to the system. The system shall be the Electro-Voice TL606DMT.

Warranty (Limited)

Electro-Voice products are guaranteed against malfunction due to defects in materials or workmanship for a specified period, as noted in the individual product-line statement(s) below, or in the individual product data sheet or owner's manual, beginning with the date of original purchase. If such malfunction occurs during the specified period, the product will be repaired or replaced (at our option) without charge. The product will be returned to the customer prepaid.

Exclusions and Limitations: The Limited Warranty does not apply to: (a) exterior finish or appearance; (b) certain specific items described in the individual product-line statement(s) below, or in the individual product data sheet or owner's manual; (c) malfunction resulting from use or operation of the product other than as specified in the product data sheet or owner's manual; (d) malfunction resulting from misuse or abuse of the product; or (e) malfunction occurring at any time after repairs have been made to the product by anyone other than Electro-Voice or any of its authorized service representatives. **Obtaining Warranty Service:** To obtain warranty service, a customer must deliver the product, prepaid, to Electro-Voice Service or any of its authorized service representatives together with proof of purchase of the product in the form of a bill of sale or receipted invoice. A list of authorized service representatives is available from Electro-Voice Service at 600 Cecil Street, Buchanan, MI 49107 (800/234-6831 or FAX 616/6955-4743). **Incidental and Consequential Damages Excluded:** Product repair or replacement and return to the customer are the only remedies provided to the customer. Electro-Voice shall not be liable for any incidental or consequential damages including, without limitation, injury to persons or property or loss of use. Some states do not allow the exclusion or

TL606DMT Low-Frequency Speaker System

limitation of incidental or consequential damages so the above limitation or exclusion may not apply to you. **Other Rights:** This warranty gives you specific legal rights, and you may also have other rights which vary from state to state.

Electro-Voice Speakers and Speaker Systems are guaranteed against malfunction due to defects in materials or workmanship for a period of five (5) years from the date of original purchase. The Limited Warranty does not

apply to burned voice coils or malfunctions such as cone and/or coil damage resulting from improperly designed enclosures. Electro-Voice active electronics associated with the speaker systems are guaranteed for three (3) years from the date of original purchase. Additional details are included in the Uniform Limited Warranty statement.

For warranty repair, service information, or a listing of the repair facilities nearest you, contact the service repair department at: 616/

695-6831 or 800/685-2606.

For technical assistance, contact Technical Support at 800/234-6831 or 616/695-6831, M-F, 8:00 a.m. to 5:00 p.m. Eastern Standard time.

Specifications subject to change without notice.

TL606DMT Low-Frequency Speaker System

Figure 1—Polars

— HORIZONTAL
 - - - VERTICAL
 5 dB per division

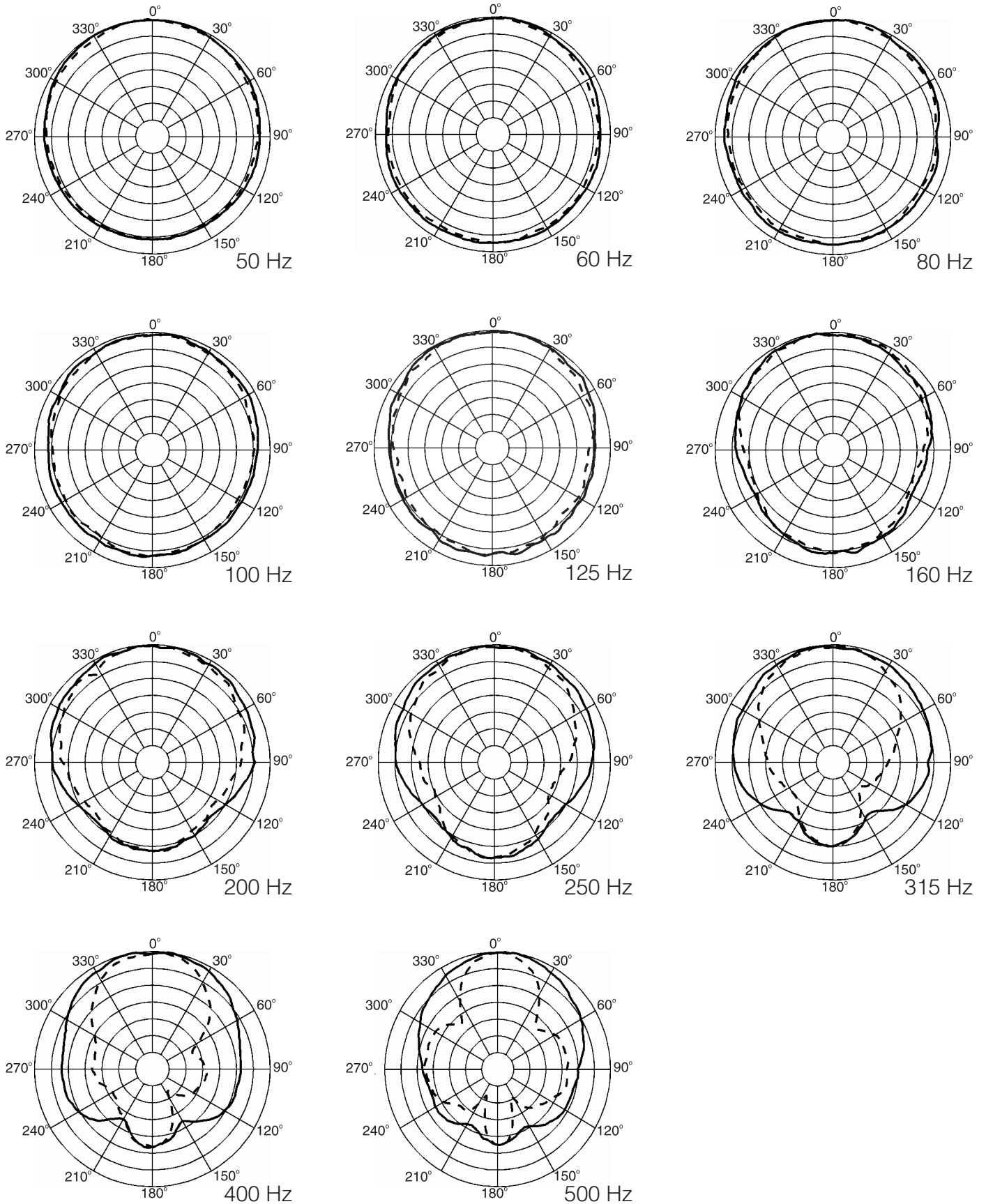

TL606DMT Low-Frequency Speaker System

TL606DMT Low-Frequency Speaker System

Figure 2—Frequency Response
4 volts/10 feet

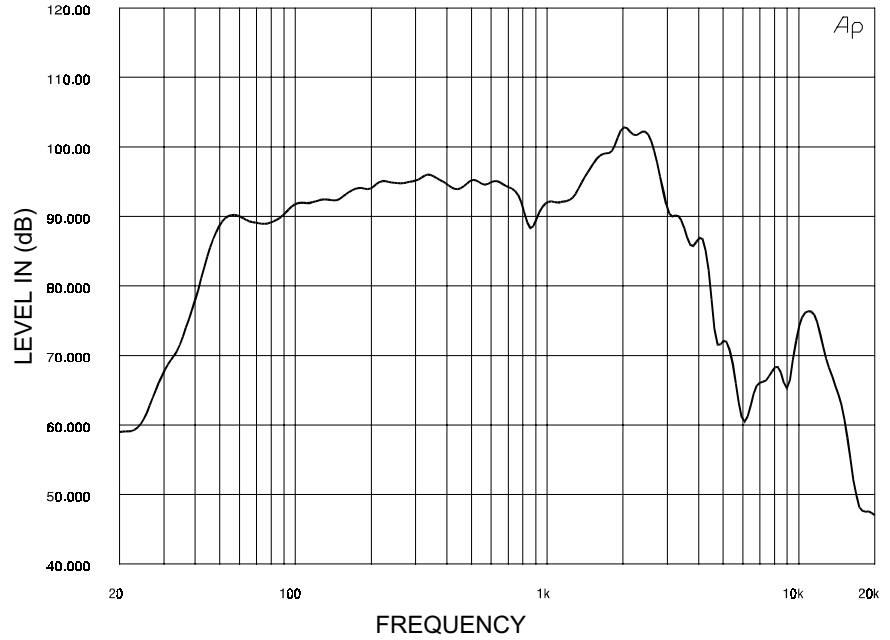

Figure 3—Beamwidth

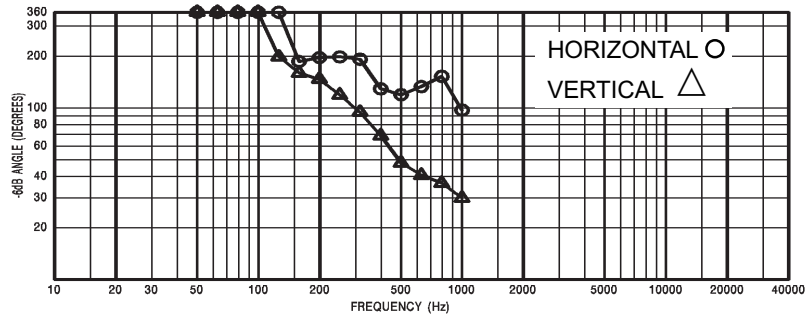
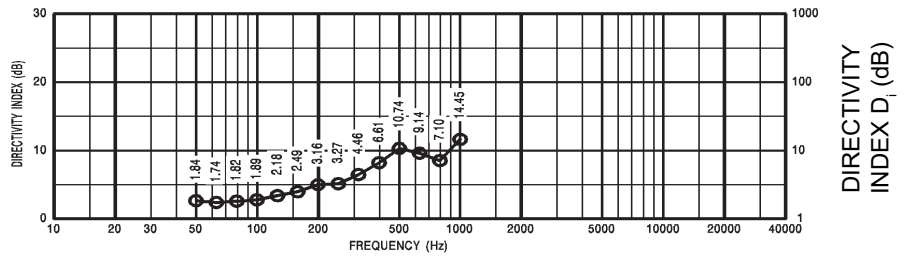
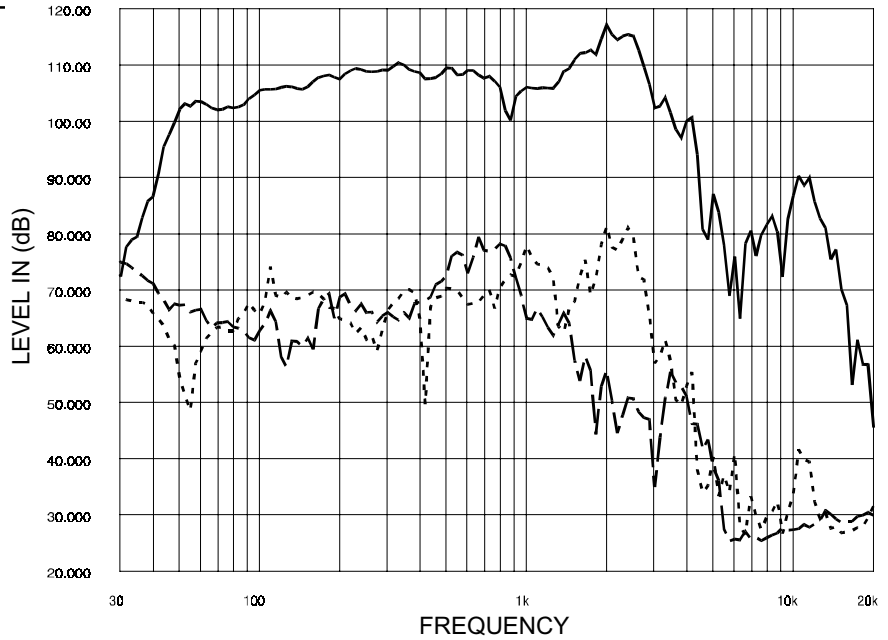

Figure 4—Directivity



TL606DMT Low-Frequency Speaker System

Figure 5—Harmonic Distortion
0.10 rate power input (80 watts)
10 feet on axis



TL606DMT Low-Frequency Speaker System

Figure 6—Vertical & Horizontal Mounting Methods for the TL606DMT Using the BMK-1 Hanging Kit

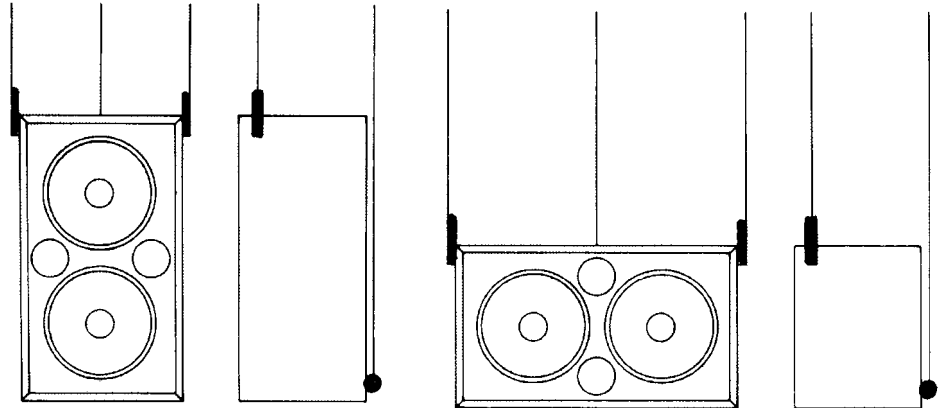

TL606DMT Low-Frequency Speaker System

TL606DMT Low-Frequency Speaker System

specifications

Frequency Response, 10 Feet on Axis, Swept One-Third-Octave Pink Noise, Half-Space Anechoic Environment (see Figure 1):
40-3,500 Hz

Low-Frequency 3-dB-Down Point, Normal:
40 Hz

Usable Low-Frequency Limit (10-dB-down point), Normal:
30 Hz

Half-Space Reference Efficiency:
5.8%

Long-Term Average Power Handling Capacity per EIA Standard RS-426A (see Power Handling Capacity section):
800 watts

Maximum Long-Term Average Mid-Baud Acoustic Output:
11.6 watts

Sound Pressure Level at 1 Meter, 1 Watt Input, Anechoic Environment, Band-Limited Pink-Noise Signal,

100-800 Hz:
100 dB

40-125 Hz:
96 dB

Dispersion Angle Included by 6-dB-Down Points on Polar Responses, Indicated One-Third-Octave Bands of Pink Noise (see Figure 3),

40-125 Hz Horizontal and Vertical:
360°

400-800 Hz Horizontal:
120° ±12°

400-800 Hz Vertical:
55° ±14°

Directivity Factor $R_q(Q)$, Median Over Indicated Range (see Figure 4),

40-125 Hz:
1.8

400-800 Hz:
5.7

Directivity Index D_i , Median Over Indicated Range (see Figure 4),

40-125 Hz:
0.0 dB

400-800 Hz:
7.6 dB

Distortion, 0.1 Full Power Input (see Figure 5),

Second Harmonic,
100 Hz:
0.45%

500 Hz:
0.28%

Third Harmonic,

100 Hz:
0.14%

500 Hz:
0.89%

Transducer Complement:

Two DL15MT woofers

Box Tuning Frequency:

40 Hz

Impedance, Minimum:

4 ohms

Input Connections:

Screw terminals (#8-32) on barrier strip

Enclosure Materials and Finish:

Black, vinyl-clad particle board

Suspension (see Suspending TL606DW Enclosures section):

Two "independently certified" suspension kits are available, the HS6 and HS7

Dimensions,

Height:

100.3 cm (39.5 in.)

Width:

57.2 cm (22.5 in.)

Depth:

44.7 cm (17.6 in.)

Net Weight:

49.0 kg (108 lb)

Shipping Weight:

54.4 kg (120 lb)

Electro-Voice®

600 Cecil Street, Buchanan, MI 49107

800/234-6831, 616/695-6831, 616/695-1304 Fax, www.electrovoice.com