

S_b121a

300-Watt Powered Bass Module

- Internal, 300-watt continuous, 600-watt dynamic power amplifier
- Lightweight (35 lb) and compact
- Very strong structural-foam enclosure with integral handle
- Stand mountable and arrayable
- High output—120 dB at 1 meter
- DL12Sx 12-inch woofer with Kevlar® reinforced cone for reliable performance
- Three molded-in attachment points (metric M8 x 1.25) for secure suspension
- CE -approved, 230-volt version available

General Description

The Electro-Voice S_b121a is an amplified, 300-watt bass module designed for sound reinforcement. Through the extensive use of computer-aided design and modeling, Electro-Voice engineers have developed a low-frequency enhancement system that combines the advantages of a long-throw 12-inch woofer, a high-impact polypropylene structural-foam cabinet and state-of-the-art high power amplifier.

Low-Frequency Driver Description

The DL12Sx low-frequency driver was specially developed for the S_b121a. At the heart of this driver, is a magnetic structure optimized to yield the best possible Thiele-Small parameters to match both the tuned enclosure and the power amplifier.

The woofer features beryllium copper lead wires, a low-mass edge-wound voice coil and high-temperature materials. The part of the magnet structure adjacent to the coil is insulated using the exclusive EV PROTEF™ process (U.S. Patent #4,547,632). The coil is driven by a massive, 16-lb magnet structure.

Enclosure Description

The enclosure is constructed of high-impact polypropylene structural foam. It provides a stiff and extremely durable enclosure. Molded into the cabinet are an integral carrying handle and a stand socket for mounting on 1³/₈-inch stands such as the Electro-Voice 100BK. Rubber feet that are attached to the bottom of the cabinet and the mating sockets that are molded into the top provide a means of stacking systems. Three attachment points are also provided (metric M8 x 1.25).

X_p200A Electronic System Controller

The optional X_p200A electronic system controller complements the characteristics of the S_b121a. Its mono-summed subwoofer outputs provide additional crossover and infrasonic protection. Its 24-dB-per-octave filters roll-off response below 37 Hz and above 100 Hz. The X_p200A also includes a special low-frequency profile circuit that enhances the performance of the S_b121a. The amount of enhancement can be adjusted to suit the user's personal preference.

Electronics Operation and Installation

To facilitate operation and installation, S_b121a back-panel detail is shown in Figure 3.

Precautions

Please read the entire data sheet before connecting the S_b121a to your system. For optimum performance, observe the following precautions:

1. Keep the ac power switch off while making connections.
2. Be certain that plugs are tightly mated. Loose connections cause hum, noise or intermittences that could damage your speakers.
3. Use the proper, high-quality shielded cables in your entire system. Low-capacitance cable is preferred.
4. Turn on the mixer, EQ and effects first. Wait eight to 10 seconds, then turn on the S_b121a. This prevents any transient "pop" which could damage a loud-speaker.
5. Always begin with the mixer master faders at minimum. Wait a few seconds to turn up the volume.

S_b121a 300-Watt Powered Bass Module

6. Use restraint in operating controls. Move them slowly. Rapid movements could damage speakers through accidental amplifier clipping.
7. To prevent fire or electrical shock, do not expose the S_b121a to rain or excess moisture.
8. Do not be concerned when the speaker "pops" when turned on. This is intentional to indicate status and does not signify a problem.

Signal Input

The S_b121a may be driven by any line-level signal source, balanced or unbalanced. **Caution: do not connect the output of a power amplifier to the input.** Although this should not damage the S_b121a, it is very likely to result in distorted sound quality because the output voltage of a power amplifier is typically high enough to severely clip the input of the S_b121a.

The connector accepts a balanced signal from a 3-pin male XLR-type connector.

Driving Multiple S_b121a's

The high, 10,000-ohm input impedance allows several S_b121a systems to be connected in parallel (daisy chained) to the usual single signal source, without undesirable loading effects on the source.

The 3-pin male XLR-type Full-Range Output connector is in parallel with the Input connector and should be used for this purpose. Pins 1 and 3 will be common and pin 2 will be hot.

Amplifier Controls and Indicators

The amplifier has minimal controls, for ease of use in the field.

The System Gain control adjusts the output of the system in order to help balance the output of the S_b121a with the rest of your system. The fully clockwise setting has 0-dB attenuation and fully counter-clockwise offers full attenuation.

Ventilation

The metal amplifier plate on the rear of the enclosure serves as a thermal radiator to maintain the amplifier operating temperature within design limits. It is normal for this panel to become warm in use, particularly when the system is operated at high levels for a prolonged period of time. During operation, use care to ensure that there is at least one inch of space behind the panel to allow free circulation of air. Worst-case temperature rise is approximately 20 °C (36 °F).

Electronic Crossover

The S_b121a is equipped with a built-in crossover, a second-order, 24-dB-per-octave low-pass filter at 125 Hz. In combination with the speaker/enclosure response, this filter provides the 250-Hz overall upper response limit noted in the specifications. The attenuation of frequencies above 125 Hz helps the bass enhancement not "muddy up" vocals or call attention to the physical location of the S_b121a.

The S_b121a may be driven by the low-frequency output of an external active crossover network. A crossover frequency in the range of 100-200 Hz is recommended. (The closer the crossover frequency is to 100 Hz, the least the overall sound quality will be affected by the enhancement of the bass module.)

Subpassband Speaker Protection

The S_b121a has a built-in, 12-dB-per-octave high-pass filter at 25 Hz, for infrasonic speaker protection.

The S_b121a may be used with an external high-pass filter for additional infrasonic protection. For 12-dB-per-octave networks, a corner frequency as high as 40 Hz (0.8 the box-tuning frequency) provides maximum protection without affecting sound quality. For higher roll-off rates, lower corner frequencies are permissible and provide essentially equivalent protection.

Suspending S_b121a Enclosures

WARNING: Suspending any object is potentially dangerous and should only be

attempted by individuals who have a thorough knowledge of the techniques and regulations of rigging objects overhead. Electro-Voice strongly recommends that the S_b121a be suspended taking into account all current national, federal, state and local regulations. It is the responsibility of the installer to ensure the S_b121a is safely installed in accordance with all such regulations. If the S_b121a is suspended, Electro-Voice strongly recommends that the system be inspected at least once a year. If any sign of weakness or damage is detected, remedial action should be taken immediately.

A manual entitled *Suspending System 200™ Loudspeakers* is included with every S_b121a system. It gives a summary of the suspension kits available and an idea of how each kit is used. A brief overview, which illustrates some approaches for single and multiple suspension, is given here for the benefit of the system designer. Please refer to individual suspension kit engineering data sheets for full details and safety information.

The first approach is to suspend an **individual** S_b121a enclosure. Electro-Voice recommends the use of the M_b200 bracket (see Figure 4), which encompasses the top and bottom of the enclosure and has additional features to make suspending the S_b121a easier and more flexible. The M_b200 has supplementary holes to allow the S_b121a to be attached to a wall or ceiling and aimed at an audience.

The M_b200 installation kit also allows the use of OmniMount® Series 100 mounting hardware by providing three-hole-pattern groups compatible with these support systems. When OmniMount® Series 100 mounting hardware is specified, the M_b200 installation kit must first be attached to the speaker enclosure.

The second approach is to suspend **multiple** S_b121a enclosures. If an "array" is required, then multiple M_b200's must be used. Arrays may be constructed vertically by "daisy chaining" two M_b200's from each other. The M_b300 horizontal array kit allows the easy and secure construction of horizontal arrays using M_b200's to support the enclosure.

S_b121a 300-Watt Powered Bass Module

System Response Due to the Acoustical Environment

Several factors must be considered when determining the overall response of a speaker system in any listening environment. Physical characteristics of the room itself and placement of the speakers and listener can have considerable affect on SPL capability, perceived and/or measured frequency response and stereo imaging.

The low-frequency response of the S_b121a can be adversely affected by poor placement. The S_b121a was designed for quarter- or half-space use. This requires that the speaker system be positioned as close as possible to floor or wall surfaces (half space) or a floor/wall junction (quarter space). Corner placement, in most cases, will reinforce low frequencies the most. Also, placement in loose cavities or resonant mountings can seriously degrade the overall response.

Architects' and Engineers' Specifications

The loudspeaker system shall consist of a 12-inch long-throw low-frequency transducer mounted in a two-piece vented enclosure made of black textured injection-molded polypropylene structural foam. The system will have a self-contained high-power amplifier, with switchable fourth-order, 24-dB-per-octave low-pass network at a frequency of 125 Hz.

The loudspeaker system shall have an operating bandwidth of 50 Hz to 250 Hz. The sound pressure level shall be 120 dB at maximum gain, with an input signal of +4 dBu into the power amplifier's balanced input and the amplifier at clipping threshold, measured at 1 meter on the system axis.

The power amplifier section shall be capable of providing 300 watts into a 4-ohm reactive load with 0.5% total harmonic distortion at 100 Hz (typical). The power band-

width shall extend from 25 Hz to 175 Hz. The amplifier shall accept both balanced and unbalanced inputs and an input impedance of 10 kilohms.

There will be three metric M8 x 1.25-mm attachment points capable of supporting the system in a permanent installation application. The loudspeaker shall have a black, perforated metal grille covering the woofer. Overall dimensions shall be 587 mm (23.1 in.) high, 429 mm (16.9 in.) wide, 312 mm (12.3 in.) deep. The weight shall be 15.9 kg (35 lb).

The loudspeaker system shall be the Electro-Voice S_b121a.

Uniform Limited Warranty

Electro-Voice products are guaranteed against malfunction due to defects in materials or workmanship for a specified period, as noted in the individual product-line statement(s) below, or in the individual product data sheet or owner's manual, beginning with the date of original purchase. If such malfunction occurs during the specified period, the product will be repaired or replaced (at our option) without charge. The product will be returned to the customer prepaid.

Exclusions and Limitations: The Limited Warranty does not apply to: (a) exterior finish or appearance; (b) certain specific items described in the individual product-line statement(s) below, or in the individual product data sheet or owner's manual; (c) malfunction resulting from use or operation of the product other than as specified in the product data sheet or owner's manual; (d) malfunction resulting from misuse or abuse of the product; or (e) malfunction occurring at any time after repairs have been made to the product by anyone other than EVI Audio Service or any of its authorized service representatives. **Obtaining Warranty Service:** To obtain warranty service, a customer must deliver the product, prepaid, to EVI Audio

Service or any of its authorized service representatives together with proof of purchase of the product in the form of a bill of sale or receipted invoice. A list of authorized service representatives is available from EVI Audio Service at 600 Cecil Street, Buchanan, MI 49107 (800/234-6831 or FAX 616/695-4743). **Incidental and Consequential Damages Excluded:** Product repair or replacement and return to the customer are the only remedies provided to the customer. Electro-Voice shall not be liable for any incidental or consequential damages including, without limitation, injury to persons or property or loss of use. Some states do not allow the exclusion or limitation of incidental or consequential damages so the above limitation or exclusion may not apply to you. **Other Rights:** This warranty gives you specific legal rights, and you may also have other rights which vary from state to state.

Electro-Voice Speakers and Speaker Systems are guaranteed against malfunction due to defects in materials or workmanship for a period of five (5) years from the date of original purchase. The Limited Warranty does not apply to burned voice coils or malfunctions such as cone and/or coil damage resulting from improperly designed enclosures. Electro-Voice active electronics associated with the speaker systems are guaranteed for three (3) years from the date of original purchase. Additional details are included in the Uniform Limited Warranty statement.

For warranty repair, service information, or a listing of the repair facilities nearest you, contact the service repair department at: 616/695-6831 or 800/685-2606.

For technical assistance, contact Technical Support at 800/234-6831 or 616/695-6831, M-F, 8:00 a.m. to 5:00 p.m. Eastern Standard time.

Specifications subject to change without notice.

Sb121a 300-Watt Powered Bass Module

Figure 1—Sb121a Frequency Response (1 watt/1 meter, anechoic environment)

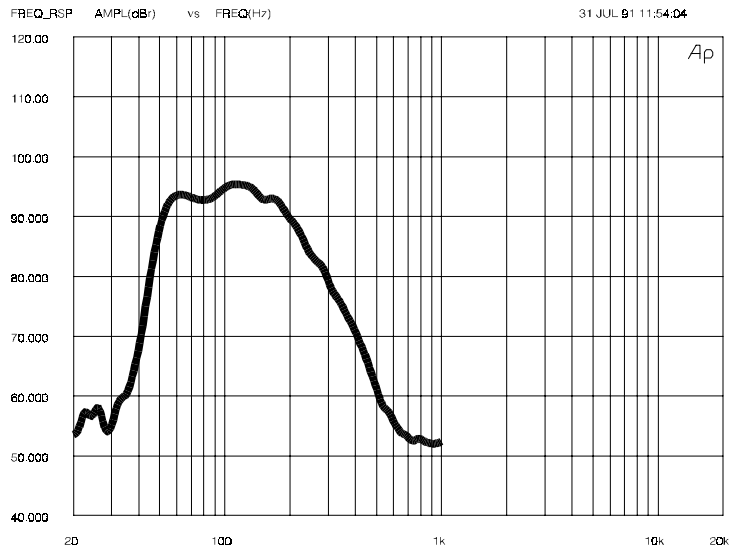

Sb121a 300-Watt Powered Bass Module

Figure 2—Sb121a Dimensions

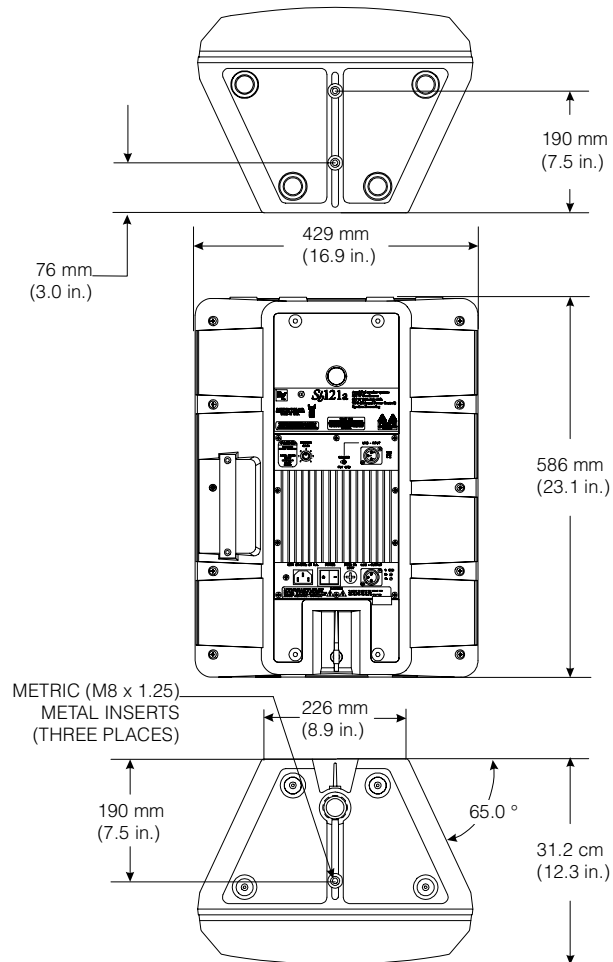

Sb121a 300-Watt Powered Bass Module

Figure 3—S_b121a Amp Panel
(110-volt version)

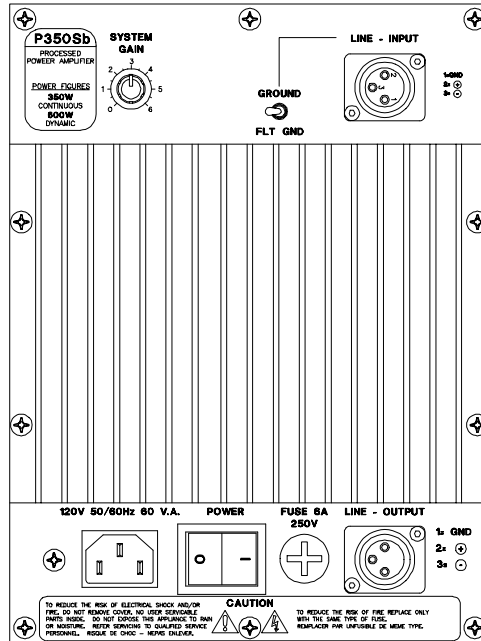

Sb121a 300-Watt Powered Bass Module

FIGURE 4 — Suspending the S_b121a
Using the M_b200 Installation Kit

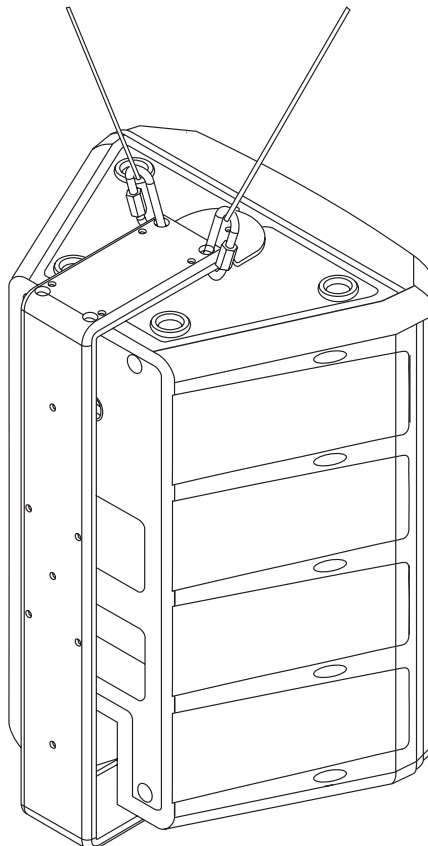

S_b121a 300-Watt Powered Bass Module

S_b121a 300-Watt Powered Bass Module

Specifications- System

Axial Frequency Response (swept sine-wave input, 4 volts measured at speaker terminals, at 10 feet on axis, anechoic environment normalized for 1 watt/1 meter; see Figure 1):
50-250 Hz

Low-Frequency 3-dB-Down Point:
50 Hz

Usable Low-Frequency Limit with Xp200A Controller (10-dB-down point):
43 Hz

Sound Pressure Level at 1 Meter, Maximum Gain and Amplifier at Clipping Threshold, 0 dBu (0.775 volts rms) into Balanced Input, Anechoic Environment, 50- to 200-Hz Average:
125 dB

Maximum Acoustic Output:
11.1 watts

Electronic Crossover, Frequency:
123 Hz

Slope:
24 dB per octave

Dispersion Angle Included by 6-dB-Down Points on Polar Responses, Essentially Omnidirectional.

Distortion, 0.1 Full Power Output, Second Harmonic, 100 Hz:
3.7%

Third Harmonic, 100 Hz:
0.8%

Transducer Complement,
12-inch EV woofer

Box-Tuning Frequency:
60 Hz

Enclosure Materials and Colors:
Black polypropylene structural foam

Supplied Accessories:
Suspending System 200™ Loudspeakers instruction manual

Optional Accessories:
100BK mounting stand
F200 monitor feet
Mb200 installation kit
Mb300 horizontal array kit
VPCsX protective cover
PDSx padded cover

Other Product Available for Enhancement of S_b121a Performance:

Xp200A electronic system controller

Attachment Points:
Three metric metal inserts (M8 x 1.25) (see Figure 2 and Suspending the Sx300a Enclosure section)

Safety Approvals (in progress):
UL-813; CSA-C22.2; IEC-65 (ENG-0065); EMC Directive for European RFI/EMI emissions

Dimensions (see Figure 2),

Height:
586 mm (23.1 in.)

Width:
429 mm (16.9 in.)

Depth:
312 mm (12.3 in.)

Net Weight:
21.3 kg (47.0 lb)

Shipping Weight:
22.6 kg (49.9 lb)

Specifications -Amplifier

System Output Power, Continuous (4-ohm load, 100- to 130-volt or 200- to-250-volt, 50/60-Hz ac line voltage):

300 watts

Frequency Response (±0.5 dB):
50-250 Hz

Total Harmonic Distortion (100 Hz),
< 0.5%

Input,

Type:

True balanced, electronic
Sensitivity (for 300-Watt, unclipped output), *

System Gain Control Full Clock wise:
0 dBu (0.775 volts)

System Gain Control Full Counter clockwise (input closed):
−∞ dBu

Impedance:

10 kilohms

Controls and Indicators:

System Gain control (0 to −∞ dB) Power on-off switch (illuminated when on)

Connectors:

XLR-type jack in parallel with 3-pin male XLR-type jack (allows paralleling of S_b121a's)

Polarity (for positive sound pressure):

Pin 2 positive

Power,

Requirement (per UL-813, maximum average, soft-start power supply):
500 watts

Minimum Service Amperage:

6 amps

Input Voltage,

S_b121a:

100-130 V, 50/60 Hz ac

S_b121a Export:

200-250 V, 50/60 Hz ac

Input Connector:

IEC

AC Line Cord (detachable, supplied):

S_b121a:

3.0-m (10-ft) three-conductor polarized cable

S_b121a Export:

2.5-m (8.2-ft) two-conductor nonpolarized cable with continental-Europe-type wall plug.

*see analog processing section for specific details

Electro-Voice®

600 Cecil Street, Buchanan, MI 49107

616/695-6831, 616/695-1304 Fax

©EVI Audio 1997 • Litho in U.S.A.