

Electro-Voice®

a MARK IV company

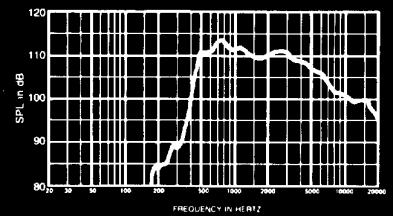

FIGURE 1
Axial Frequency Response, 1 Watt/1 Meter
Curved on HP9040 Horn

Model N/DYM™ 1 Model N/DYM™ 1-16 High-Frequency Reproducers

SPECIFICATIONS

The following specifications are in accordance with or exceed the AES Recommended Practice for Specification of Loudspeaker Components Used in Professional Audio and Sound Reinforcement (AES2-1984; ANSI S4.26-1984). See AES Recommended Practice section.

Power Frequency Response:

500-20,000 Hz (essentially flat)
500-5,000 Hz with 6-dB-per-octave rolloff to 20,000 Hz, rapid rolloff beyond)

Nominal Impedance,

N/DYM™ 1:

8 ohms

N/DYM™ 1-16:

16 ohms

Minimum Impedance, on HP Series Horns

Above 500 Hz,

N/DYM™ 1:

7 ohms at 6,000 Hz

N/DYM™ 1-16:

14 ohms at 6,000 Hz

Nominal dc Resistance,

N/DYM™ 1:

4.5 ohms

N/DYM™ 1-16:

10.5 ohms

Long-Term Average Power Capacity on HP

Horns, Indicated Bands of Pink Noise,

8-Ohm Impedance Assumed,

24 Hours, 6-dB Crest Factor:

50 watts (500-20,000 Hz)

2 Hours, 6-dB Crest Factor:

75 watts (1000-10,000 Hz)

Nominal Efficiency, 1,000-5,000-Hz Pink

Noise, 8-Ohm Impedance Assumed:

28%

Maximum Long-Term Acoustic Power

Output (24 hours):

14 watts

Recommended Minimum Crossover

Frequency:

500 Hz

Sound Pressure Level at 1 Meter, 1 Watt Input Averaged from 500 Hz to 5,000 Hz:¹

115 dB, HP4020 horn

113 dB, HP6040 horn

111 dB, HP9040 horn

114 dB, HP420 horn

112 dB, HP640 horn

110 dB, HP940 horn

108 dB, HP1240 horn

Throat Diameter:

4.92 cm (1.94 in.)

Voice Coil Diameter:

7.62 cm (3.00 in.)

Voice Coil Construction:

Rectangular edge-wound pure aluminum wire on a high-temperature polyimide form.

Diaphragm Construction:

Integral all-titanium construction consisting of spherical diaphragm dome and geometrically optimized suspension; a low-fatigue, high temperature, long-duration-cure engineering polymer bonds the coil form to the diaphragm.

Electrical Connection:

Screw terminals, each of which will accept a pair of 12-gauge wires and any smaller size.

Polarity:

A positive voltage applied to the positive (+) terminal produces a positive acoustic pressure in the throat.

Mechanical Connection:

Bolt on,

4 equally spaced holes on a 10.2 cm (4.00 in.) diameter circle, ¼"-20 threads, bolts supplied with HP series horns

Dimensions (see Figure 2),

Overall Diameter:

14.5 cm (5.7 in.)

Overall Depth:

12.7 cm (5.0 in.)

Net Weight:

3.3 kg (7.2 lb)

Shipping Weight:

3.7 kg (8.2 lbs)

1. Measured on axis in the far field with 1 watt input of band-limited pink noise from 500-5,000 Hz and calculated to 1 meter equivalent by inverse square law.

DESCRIPTION

The Electro-Voice N/DYM™ 1 is a world-class, high-frequency compression driver capable of unprecedentedly high acoustic power output over an extremely wide frequency range.

This performance results from careful engineering and design, involving expert choices of material and advanced driver architecture which are ideally suited for efficient presentation of high-quality musical and communication program material. Features of the N/DYM™ 1 include:

1. A unique, geometrically-optimized diaphragm consisting of a one-piece dome and suspension fabricated from titanium. Advanced metal forming and processing technology developed by EV engineers allows this high-elongation diaphragm design to be formed from .0015-inch thick material. The combination of diaphragm geometry and material choice gives the N/DYM™ 1 diaphragm an ideal combination of superb high-frequency response and resistance to fatigue from stress.
2. A unique neodymium alloy (NdFeB) magnetic system which provides unsurpassed amplifier-to-diaphragm coupling. This gives the N/DYM™ 1 unusual bandwidth extension, high efficiency and a musical depth and transient clarity not normally associated with compression drivers. The drive system consists of the following advanced features:
 - a) An optimized and balanced magnetic circuit which provides a flux density of 2.25 Tesla (22.5 kilogauss). This represents the highest flux density currently available.

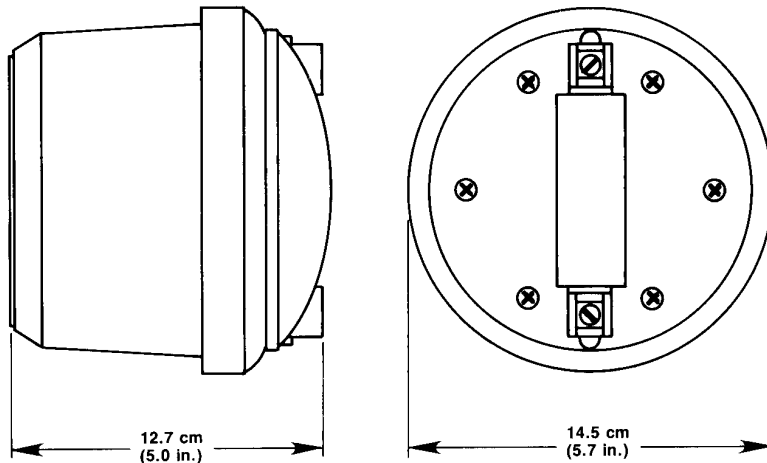

FIGURE 2
Dimensions

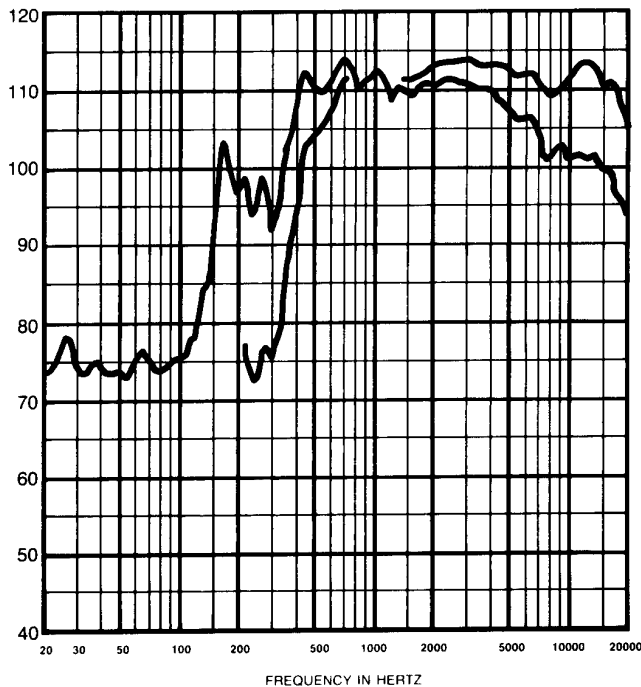

FIGURE 3
Axial Frequency Response with and without
Equalization, 1 Watt/1 Meter, HP9040 Horn

b) A precision, lightweight voice-coil made from pure aluminum rectangular wire, which gives the N/DYM™ 1 high motor strength and maximum efficiency.

Proprietary high-temperature winding and electrical bonding technologies assure excellent coil reliability and performance.

c) EV-exclusive PROTEF™ (Patent no. 4547632) voice-coil protection; a Teflon-based coating, applied to the top plate. Occasionally, violent power peaks of several seconds in duration may expand a normal driver's voice coil into contact with the top plate, causing deterioration. With the PROTEF coating, added protection is provided; the coating lubricates any rubbing contact and provides direct electrical insulation between the coil and the steel top plate. This feature is unique for compression drivers and is a result of Electro-Voice's exclusive "Total Thermal Engineering" approach to loudspeaker design.

3. A phase-plug design giving optimum upper-octave response.
4. Screw-type input terminals, which are an EV exclusive. They provide an unusually positive electrical connection. Each terminal will easily accept a pair of 12-gauge wires, and any smaller size. These special terminals were designed using the results of an extensive field survey of consultants and sound-system installers.
5. An integral diaphragm assembly and protective cap which is an EV-exclusive design. This allows for a single operation for diaphragm removal and acts as an effective out-of-driver diaphragm protection.

RECOMMENDED HORNS

The following Electro-Voice horns are recommended for use with the N/DYM™ 1: HP64, HP94, HP420, HP640, HP940, HP1240, HP4020, HP6040, and HP9040.

CROSSOVER AND EQUALIZATION

As with all horn/driver combinations that combine high overall efficiency with constant directivity, the N/DYM™ 1 and HP series horns provide "raw" or unequaled frequency response that rolls off above 3,000 Hz or so at about 6 dB per octave. Figure 3 shows the N/DYM™ 1 on an HP9040 horn, with and without equalization. The equalization has been provided by Electro-Voice XEQ-2 or XEQ-3 crossover/equalizers equipped with the EQU equalization module. While the equalization of constant-directivity horn/driver combination can be achieved with a conventional one-third-octave equalizer, the use of

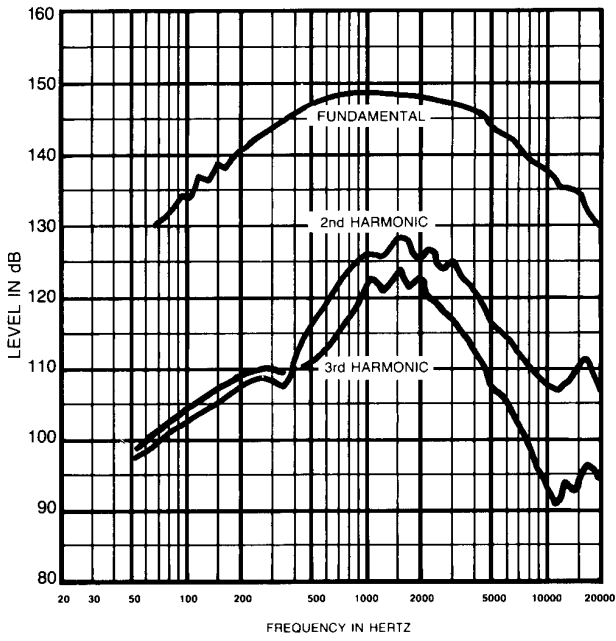

FIGURE 4
Distortion Response,
2-Inch Plane-Wave Tube, 5 Watts



FIGURE 5
Distortion Response,
HP9040 Horn, 1 Watt/1 Meter

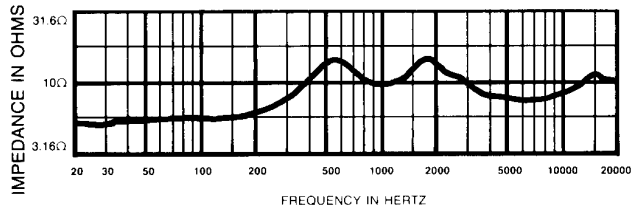

FIGURE 6
Impedance Response — 2-Inch Plane-Wave Tube
8-Ohm Driver

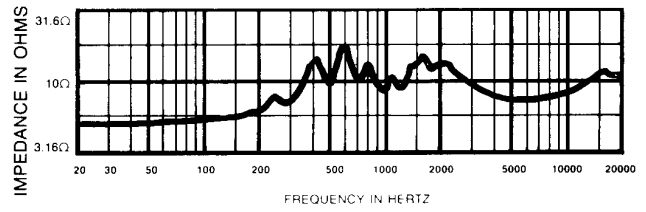

FIGURE 7
Impedance Response — HP9040 Horn
8-Ohm Driver

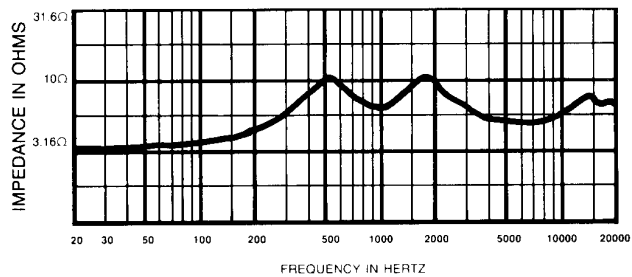

FIGURE 8
Impedance Response — 2-Inch Plane-Wave Tube
16-Ohm Driver

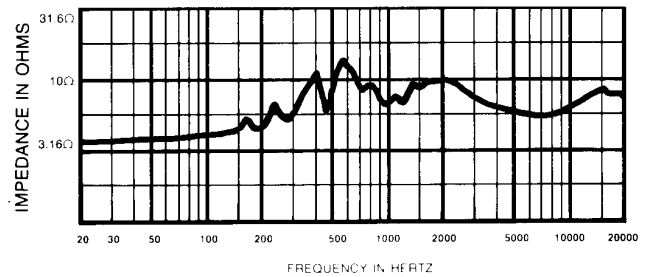

FIGURE 9
Impedance Response — HP9040 Horn
16-Ohm Driver

the XEQ-2 or XEQ-3 with the appropriate accessory EQ module is recommended. This way, the broad-band equalization required by the horn/driver combination is supplied by the crossover/equalizer network, and the one-third-octave equalizer can be devoted to correcting the more subtle room- and array-related response anomalies. The following EQ modules are available for the N/DYM™ 1:

| Module | Horn(s) |
|--------|------------------------|
| EQR | HP940 |
| EQS | HP1240 |
| EQT | HP640 |
| EQU | HP4020; HP6040; HP9040 |
| EQV | HP420 |

Refer to the XEQ-2 and XEQ-3 engineering data sheets for more information on performance and application.

For passively crossed over systems, the XEQ804 and XEQ808 crossover/equalizers are available.

FIELD REPLACEMENT

In case of voice-coil or diaphragm failure, the diaphragm cover subassembly on the rear of the driver can be field replaced by the removal of six cover screws. A replacement kit with instructions may be ordered from the Electro-Voice Service Department in Buchanan, Michigan. The appropriate repair kit part numbers are 81683XX (N/DYM 1) and 81684XX (N/DYM 1-16). If desired, the complete driver may be returned for service.

AES RECOMMENDED PRACTICE

The N/DYM™'s specifications conform to the AES Recommended Practice for Specification of Components Used in Professional Audio and Sound Reinforcement (AES2-1984; ANSI S4.26-1984). This recommended practice was developed over a number of years by consultants, manufacturers and government agencies from around the world, so that the detailed performance information required in professional applications could be provided in a unified format. The recommended practice has been published in the October, 1984, issue of the

Journal of the Audio Engineering Society (vol. 26, pp. 771-780). Individual copies of the recommended practice are available from the Audio Engineering Society, 60 East 42nd Street, New York, New York 10165, USA. Also appearing in this issue is an article which comments on the recommended practice from an engineering point of view (C.A. Henriksen, "Engineering Justifications for Selected Portions of the AES Recommended Practice for Specification of Loudspeaker Components," pp. 763-769). The comments in this article will be particularly of interest to those not involved in the day-to-day design and testing of loudspeakers.

ARCHITECTS' AND ENGINEERS' SPECIFICATIONS

The loudspeakers shall be of the compression-driver type consisting of a titanium diaphragm joined to an edge-wound aluminum ribbon voice coil on a polyimide form.

The nominal impedances shall be 8 ohms (N/DYM 1) and 16 ohms (N/DYM 1-16).

The loudspeakers exhibit essentially flat power response from 500-5,000 Hz with a smoothly rolled-off response from 5,000 to 20,000 Hz. Their efficiency shall not be less than 28%. Their sensitivity, when mounted on an EV HP4020 horn, shall be 115 dB (1W/1m) with a 500-to-5,000-Hz pink-noise signal applied.

The loudspeakers shall be capable of handling a 50-watt, 500-to-20,000-Hz pink-noise signal with a 6-dB crest factor (200 watts peak) for a period of 24 hours. In addition, they shall be capable of handling a 75-watt, 1,000-to-10,000-Hz pink-noise signal, with 6-dB crest factor for a period of two hours.

The loudspeakers shall have a diameter of 14.5 cm (5.7 in.) and a depth of 12.7 cm (5.0 in.). They shall have a 1.94-inch throat opening, with four ¼-20 threaded bolt holes on a 4-inch-diameter circle for mounting. They shall weigh no more than 3.3 kg (7.2 lbs).

The loudspeakers shall be the Electro-Voice model N/DYM™ 1, and model N/DYM™ 1-16 compression drivers.

WARRANTY (Limited)

Electro-Voice Speakers and Speaker Systems (excluding active electronics) are guaranteed for five years from date of original purchase against malfunction due to defects in workmanship and materials. If such malfunction occurs, unit will be repaired or replaced (at our option) without charge for materials or labor if delivered prepaid to the proper Electro-Voice service facility. Unit will be returned prepaid. Warranty does not extend to finish, appearance items, burned coils, or malfunction due to abuse or operation under other than specified conditions, including cone and/or coil damage resulting from improperly designed enclosures, nor does it extend to incidental or consequential damages. Some states do not allow the exclusion or limitation of incidental or consequential damages, so the above exclusion may not apply to you. Repair by other than Electro-Voice or its authorized service agencies will void this guarantee. A list of authorized warranty service agencies is available from Electro-Voice, Inc., 600 Cecil Street, Buchanan, MI 49107 (AC/616-695-6831); Electro-Voice, Inc., 10500 W. Reno, Oklahoma City, OK 73125 (AC/405-324-5311) and/or Electro-Voice West, 8234 Doe Avenue, Visalia, CA 93291 (AC/209-651-7777). This warranty gives you specific legal rights, and you may also have other rights which vary from state to state.

Service and repair address for this product: Electro-Voice, Inc., 600 Cecil Street, Buchanan, Michigan 49107.

Specifications subject to change without notice.