

EV **Electro-Voice**[®]
XEQ-3
ELECTRONIC CROSSOVER

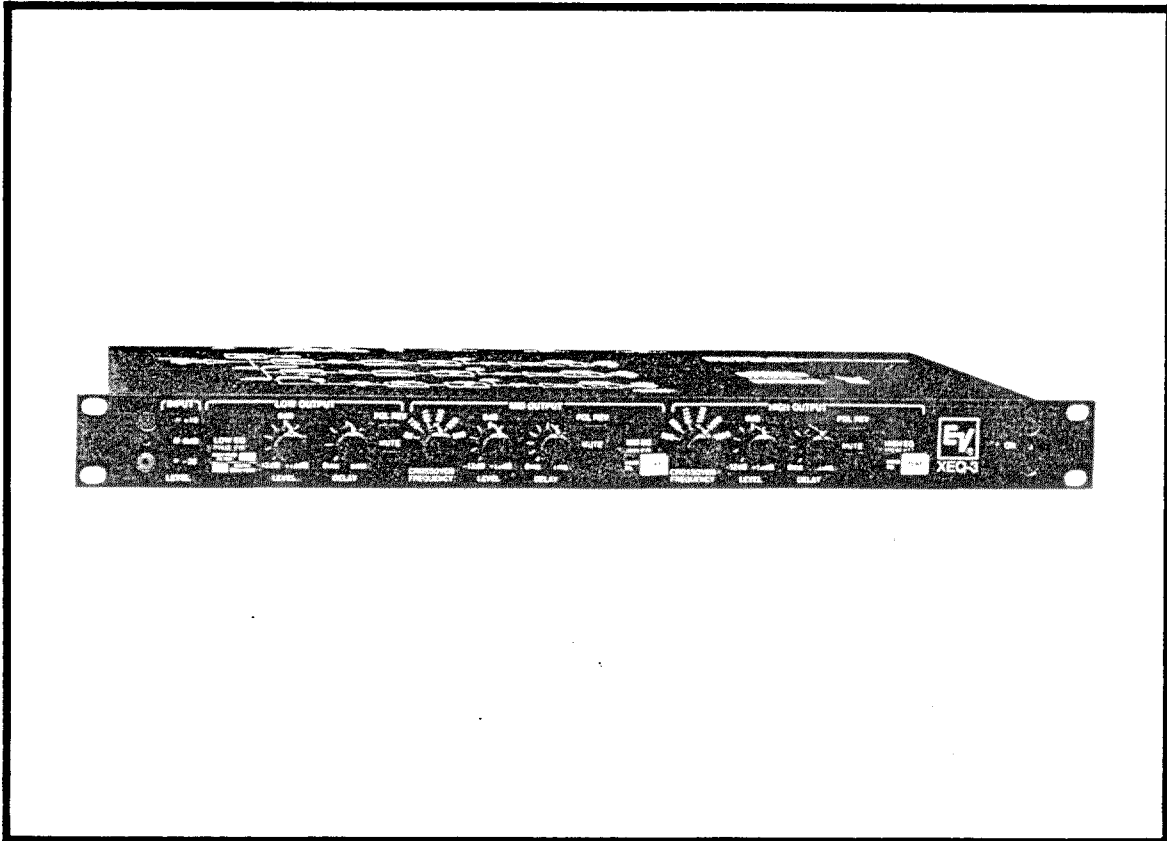

XEQ-3
ELECTRONIC
CROSSOVER

a **gulton** company

SERVICE MANUAL

TABLE OF CONTENTS

	Page
Specifications	2
Description	3
Connections	3
Control Functions	3,4
Equalization	4
Custom Low-Frequency Modules	4
Module Construction	5
Non-Standard Crossover Frequencies	5
Output Transformers	5
Figures	6
Linkwitz-Riley Filter Advantages	7
PC Board	8
Schematic	9
Schematic	10
Schematic	11
Parts List	12
Repair Parts/Warranty	13

SPECIFICATIONS

CHANNEL CONFIGURATION —

Monaural three-way, switchable to monaural two-way

FILTER TYPE —

Fourth-order Linkwitz-Riley (24-dB-per-octave attenuation)

CROSSOVER FREQUENCIES, SWITCH SELECTABLE —

(See text for other possible frequencies)

Low-Mid: 80, 125, 160, 250, 500 and 800 Hz

Mid-High: 500, 800, 1250, 1600, 5000 and 8000 Hz

OUTPUT DELAYS —

Type: Fourth-order all-pass, continuously variable time constant, linear control scale

Range: Low: 6 μ s ("0") to 6 ms

Mid: 1 μ s ("0") to 1 ms

High: 0.3 μ s ("0") to 0.3 ms

INFRASONIC SPEAKER PROTECTION —

Filter Type: Second-order Butterworth (12-dB-per-octave slope)

Corner Frequencies: 16 or 32 Hz, provided by supplied HP16/32 plug-in module (see text for other frequencies)

EQUALIZATION FOR "STEP-DOWN" OPERATION

OF TL BASS SPEAKER SYSTEMS —

Filter Type: Second-order underdamped (12-dB-per-octave rolloff below plus-6-dB peak-boost frequency)

Peak-Boost Frequencies: 29, 35, 45 and 60 Hz provided by optional EB29/35 and EB45/60 plug-in modules (see text for other frequencies)

EQUALIZATION OF MID- AND HIGH-FREQUENCY OUTPUTS, PROVIDED BY PLUG-IN MODULE —

Normally Supplied: EQF module (for flat electrical frequency response)

Optional Modules, for Flat Acoustic Response of Compression Drivers on Constant-Directivity Horns: EQA, EOB . . .

(see Table 1 for complete list)

INPUT —

Type: Active differential

Maximum Level: +18 dBu

Impedance: 20,000 ohms

Common-Mode Range: ± 24 V (net of signal voltage)

Common-Mode Rejection Ratio, Typical: -55 dB

Connector: Female 3-pin XLR type

MAIN OUTPUTS —

Type: Floating differential (TRB-2 set of three isolation transformers available; see text)

Maximum Level: +18 dBu

Impedance: 100 ohms

Minimum Load Impedance for Full Output Level: 600 ohms

Protection: Safe for short circuit or ± 25 volts dc

Connectors: Male 3-pin XLR type

LOW-MIX (COMMON-BASS) OUTPUT —

Impedance: 1,800 ohms

Connector: RCA-type phono jack

GAIN —

Level Controls at Center Detent: Unity

Adjustment Range re Unity Gain, Continuously Variable: ± 12 dB

FREQUENCY RESPONSE, SUM OF OUTPUTS, LEVEL CONTROLS AT CENTER DETENT, 2,000-OHM LOADS —

20-20,000 Hz ± 0.5 dB

TOTAL HARMONIC DISTORTION, 20-20,000 Hz —

Typical: 0.02%

Maximum: 0.1%

NOISE, EACH OUTPUT, CONTROLS FLAT, 20-20,000-Hz NOISE BANDWIDTH —

Typical: -90 dBu

CHANNEL CROSSTALK —

Typical: -78 dB

TRANSIENT PERFORMANCE —

Not limited by slew rate or power bandwidth under normal operating condition, 20-20,000 Hz

LED LEVEL INDICATORS —

(Level-dependent brightness provides enhanced resolution)

Green: Input level above -20 dBu

Yellow: Input level above 0 dBu

Red: Input or any output level above +16 dBu

FRONT-PANEL CONTROLS —

Each Output: Gain, delay, polarity and channel mute

CHASSIS CONSTRUCTION —

Painted aluminum

COLORS —

Black with white graphics

MOUNTING —

Standard 19-in. rack panel, 1 $\frac{3}{4}$ in. high, 7 in. deep behind panel

SUPPLIED ACCESSORIES —

HP16/32 plug-in high-pass filter module for 16- or 32-Hz low-frequency protection; BMK blank plug-in module for construction of custom modules; smoked acrylic security cover

OPTIONAL ACCESSORIES —

EQA, EOB . . . plug-in equalization modules for flat acoustic response of compression drivers on constant-directivity horns (see Table 1 for complete list); TRB-2 set of three output isolation transformers

POWER REQUIREMENTS —

100-120 V ac, 60-60 Hz, 10 W

(also available for 80-110 and 220-240 V ac, 50-60 Hz)

OVERALL DIMENSIONS —

(see Figure 1)

44 mm (1.73 in.) high;

483 mm (19.0 in.) wide;

185 mm (7.28 in.) deep

NET WEIGHT —

3.1 kg (6.8 lb)

SHIPPING WEIGHT:

3.8 kg (8.4 lb)

DESCRIPTION

The XEQ-3 electronic crossover/equalizer is intended primarily for high-quality sound systems which require precise crossover filtering and accurate speaker system compensation for optimum frequency and time response. The XEQ-3 incorporates fourth-order Linkwitz-Riley frequency-dividing networks which have two unique advantages over the third-order Butterworth networks often used in high-performance professional sound systems. First, a fourth-order network offers an out-of-passband attenuation rate of 24 dB per octave, greater than the 18-dB-per-octave rate of a third-order network. This provides better protection of drivers from energy outside their frequency range, important in some applications. Second, the Linkwitz-Riley network has "zero lobing error," for smoother overall frequency response in the crossover region. This concept is treated in more detail in the section below.

Each output of the XEQ-3 has a variable time-delay equalizer which is capable of compensating for different speaker mounting positions and phase responses, so that proper acoustic summing will occur at the crossover frequencies. Each output also has an EQ section controlled by a plug-in module. The LOW EQ can be used as an infrasonic filter or for "step-down" operation of TL bass speaker systems. The MID EQ and HIGH EQ are designed to provide constant-directivity horn and driver equalization when used with the appropriate module. The XEQ-3 is supplied with an HP16/32 module (infrasonic filter at 16 or 32 Hz) for the LOW EQ and two EQF modules (flat response, no EQ) for the MID EQ and HIGH EQ sections. Other modules can be ordered from Electro-Voice or custom built using the supplied BMK blank module.

Other features include a level display for optimizing dynamic range; a level control, polarity reverse switch and mute switch for each output; switches which allow two-way crossover operation; and floating differential input and outputs. Output transformers (Electro-Voice TRB-2 set of three) can be installed if desired.

The XEQ-3 mounts in one EIA rack space and is supplied with a smoked acrylic front cover to prevent uninvited control adjustment. Figure 2 shows the XEQ-3 block diagram.

CONNECTIONS

Input and Outputs

The input connector is a 3-pin female XLR type; output connectors are 3-pin male XLR type. Pins 2 and 3 are signal and each pin 1 is ground. This grounding arrangement works well in most installations; pin 1 can be used as a ground reference or, if there is another reference (a ground loop is formed), then the resistor allows pin 1 to follow the other ground reference. A solid chassis ground connection can be obtained at the connector shell.

The floating differential input and outputs can be unbalanced and referenced to other equipment, or they can be connected to balanced lines. If a true balanced source (or load) is needed, connect a 300-ohm resistor from pin 2 to pin 1 and another 300-ohm resistor from pin 3 to pin 1.

Low Mix

The low-mix (or "common-bass") connection is an RCA phono jack which allows the low output to be mixed with the low output of another XEQ-3 or XEQ-2. This can improve the performance of stereo or multi-channel installations by equally distributing low-frequency energy among the low-frequency speakers. The low-mix connection also allows the use of a single amplifier/ subwoofer combination in stereo or multi-channel systems.

Any number of crossovers may be used this way by connecting their low-mix jacks together. When XEQ's are interconnected in the low-mix mode, any or all of the low-frequency outputs may be used. These outputs will have a common signal but their individual level, polarity, mute and delay controls will still function independently.

Power

A green LED on the front panel indicates when ac power is ON. The XEQ-3 may be left on indefinitely or externally switched with other equipment.

CONTROL FUNCTIONS

Crossover Frequency

The six-position rotary switches select the frequencies for the low-mid and mid-high crossover filters. The corresponding outputs will be 6 dB down at the selected frequency, compared to the midband response. See Figure 3.

The XEQ-3 can be modified to provide other frequencies — see Non-Standard Crossover Frequencies section.

Input Level Indicator

The level of the input signal to the XEQ-3 is monitored with three LED's. The green LED indicates signal above -20 dBu, and the yellow LED lights when the signal reaches 0 dBu. The red LED lights if the input or any output exceeds +16 dBu. In normal operation, the yellow LED should light much of the time (indicating normal signal level) but the red LED should not light.

Level Controls

Each of the three outputs has a level control with a ± 12 dB range. The center detent position is unity gain. These controls are intended for fine-tuning the system response; large differences in speaker output should be approximately compensated with the power amplifier's attenuators and then accurate level matching can be achieved with the XEQ-3 level controls.

Polarity Reverse Switches

These switches will reverse the polarity of the corresponding output. These are used primarily to assist adjustment of the delay control.

Mute Switches

When a mute switch is pressed, the corresponding output will be shut off. These are useful for setup, calibration, and troubleshooting.

Time-Delay Controls

Each output on the XEQ-3 has time-delay control which allows compensation for the time- and phase-response differences which exist in almost all practical multi-way speaker setups. The delay sections are four-pole, all-pass

Time-Delay Controls (continued)

filters with continuously variable time constants (see Figures 4 and 5). Adjusting a delay control is acoustically equivalent to physically moving the corresponding speaker with respect to the others. The delays available may not always be sufficient to compensate for all physical location differences encountered. However, half-wavelength shifts should nearly always be possible, thus eliminating the interference cancellations that can occur at crossover.

Normally only two delay controls are needed in a particular setup; the speaker with its acoustic center furthest from the listener should have its delay control left at "0." There may be exceptions to this, such as when a certain unusual time response is desired. The best way to adjust these controls is by measuring the direct-field on-axis frequency response using a plotter or a spectrum analyzer: reverse the polarity of the output to be adjusted, turn the delay control until the deepest possible response null occurs at the crossover frequency, then restore the correct polarity. The result will be optimum phase and frequency response through the crossover region. The delay controls can also be adjusted with just an oscillator, set at the crossover frequency, by listening for and adjusting the null, on axis and in the speaker system's direct sound field. Switching to the correct polarity will then yield flat response. Set the level controls first, then set the delay controls.

Two-Way Operation

The XEQ-3 can easily be set up for two-way operation by pressing one of the switches on the back panel. Which switch to press (LOW-MID or LOW-HIGH) depends on which crossover frequency range is needed. The two corresponding outputs are then used. The third output can be used also, if another speaker in a stack or cluster needs a different equalization module or control setting. For example, by pressing LOW-MID and setting both crossover frequency switches to 500 Hz or 800 Hz, the mid and high outputs have the same frequency range but separate controls and EQ. The possible combinations are shown in Figure 6.

EQUALIZATION SECTIONS

Low-Frequency Equalization

The LOW EQ socket accepts plug-in modules for different types of high-pass filters. The HP16/32 module (supplied) will provide a second-order Butterworth (maximally flat) response with a cutoff frequency of either 16 Hz or 32 Hz, depending on which number is right-side up when the module is installed. Other modules are available for "step-down" operation (low-frequency extension) of Electro-Voice TL bass speaker systems. The EB29/35 and EB45/60 provide 6 dB of boost at the corresponding peak frequencies, for this purpose. Modules can be constructed for other frequencies and high-pass filter types — see Custom Low-Frequency Modules section.

Mid- and High-Frequency Equalization

The MID EQ and HIGH EQ circuits are identical to each other, but are in the mid and high signal paths, respectively. These circuits will accurately equalize high-performance compression drivers used with constant-directivity horns. The proper EQ module for use with various EV horn-driver combinations is shown in Table 1.

For applications requiring flat electrical frequency response, use EQF modules. The XEQ-3 is supplied with EQF modules installed in the MID EQ and HIGH EQ sockets.

Model	Used With	
	Horn	Driver
EQA	HR90	DH1012A, DH1506
EQB	HR120, SM120	
EQC	HR40, HR60	
EQD	HR9040A, HR4020A	
EQE	HR6040A	
EQF	FLAT	
EQG	HR90	DH2012
EQH	HR120	
EQJ	HR40, HR60	
EQK	HR9040A, HR4020A	
EQL	HR6040A	
EQM	HP940	DH1, DH1A DH2
EQN	HP1240	
EQO	HP420, HP640	
EQP	HP9040, HP4020	
EQQ	HP6040	
EQR	HP940	DH1A
EQS	HP1240	
EQT	HP640	
EQU	HP4020, HP9040, HP6040	
EQV	HP420	

TABLE 1
Horn/Driver Equalization Modules

CUSTOM LOW-FREQUENCY MODULES

High-Pass Filters

If a low-frequency cutoff other than 16 Hz or 32 Hz is needed, a module can be constructed for other frequencies by soldering resistors into the supplied BMK blank module kit. Two resistors are needed for each filter frequency. Note that each module can accommodate two frequencies since there are two ways to plug it into the socket. One-quarter-watt film resistors having a resistance tolerance of 1% or 2% are recommended, but in less critical applications, 5% resistors may suffice. Mil-type RN55D resistors are easiest to use; however, conformally coated resistors may also be used. In the following formulas, R_1 and R_2 are in ohms, and f_3 is the corner frequency in Hz:

$$R_1 = \frac{1.06 \times 10^{13}}{4.7 \times 10^6 \times f_3 - 2.25 \times 10^6}$$

$$R_2 = \frac{R_1 \times 4.7 \times 10^6}{2 \times R_1 + 9.4 \times 10^6}$$

For maximally extended low-frequency response, use $R_1 = 1$ megohm and leave R_2 out. The f_3 will then be around 5 Hz to 10 Hz, depending on the load impedance.

Step-Down EQ Modules

To make modules for step-down equalization of low-frequency speaker systems, use the following formulas. The equalization circuit will produce a 6-dB peak at the frequency f_p and a 12-dB-per-octave rolloff below the peak:

$$R_1 = \frac{3.11 \times 10^{13}}{4.7 \times 10^6 \times f_p - 6.61 \times 10^6}$$

$$R_2 = \frac{4.43 \times 10^5}{f_p}$$

Module Construction

In addition to the Electro-Voice BMK blank module kit, the following items are required:

1. Two or four resistors, calculated from the formulas given above.
2. Low-wattage soldering iron with small chisel tip.
3. Electronic-grade solder, 63/37 or 60/40 alloy, rosin core.
4. Flush-cutting diagonal cutters.
5. A spare 16-pin DIP socket.
6. Adhesive: epoxy, super glue or hot melt.
7. Various hand tools, as needed.

Refer to the diagram in Figure 7:

1. Insert the DIP plug into the spare socket or use the one on the XEQ-3. This helps to keep the pins in alignment during soldering.
2. Locate pin 1 by the cut-off corner on the plug.
3. Place and solder the resistors one by one and trim each lead close enough to the pin to allow later installation of the cap. If you are using conformally coated (dipped) resistors, be sure the leads are free of the coating material where they emerge from the resistor body. Be careful not to overheat the pins, or the plastic base will melt.
4. Check all connections and resistor values.
5. Attach the cap with glue.
6. Label the module.

NON-STANDARD CROSSOVER FREQUENCIES

The XEQ-3 can be modified to provide crossover frequencies other than the six frequencies available at each switch. This is easily done (only resistors and a phillips screwdriver are needed) if the new crossover frequency is between 80-Hz and 800 Hz for the low-mid switch and between 500 Hz and 8,000 Hz for the mid-high switch. Four ¼-watt, 1% resistors are needed for each filter switch. For a crossover frequency f_c , the following resistor value is needed:

1. Low-mid filter:

$$R = \frac{2.83 \times 10^{10} - 3.56 \times 10^7 \times f_c}{1.98 \times 10^4 \times f_c - 1.59 \times 10^6}$$

2. Mid-high filter:

$$R = \frac{4.79 \times 10^{11} - 6.02 \times 10^7 \times f_c}{3.21 \times 10^4 \times f_c - 1.59 \times 10^7}$$

OUTPUT TRANSFORMERS

The outputs of the XEQ-3 can be transformer coupled by adding the optional TRB-2 set of three transformers to the circuit board. This should be done by a qualified service technician. Remove two screws from each side and the back, and lift off the top cover. Then remove the five screws holding the circuit board to the chassis, and four hex screws from the front panel. The circuit board, with the front panel attached, can then be removed from the chassis.

There are fourteen jumpers which must be removed from the board so that the three transformers will have the proper drive, feedback, and output connections. The jumpers are labeled JP1 through JP14. See Figure 9. To remove a jumper, clip the lead at each end and remove the center section.

The transformer lead layout is asymmetrical, so verify the orientation of the transformer leads with the holes in the circuit board before installing. Solder all connections on the foil side of the board. Reassemble the XEQ-3 in reverse order from the description above.

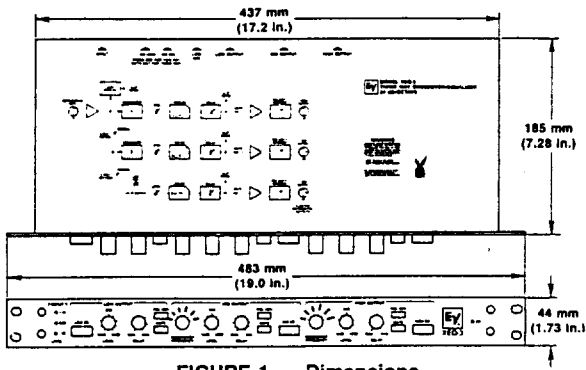

FIGURE 1 — Dimensions

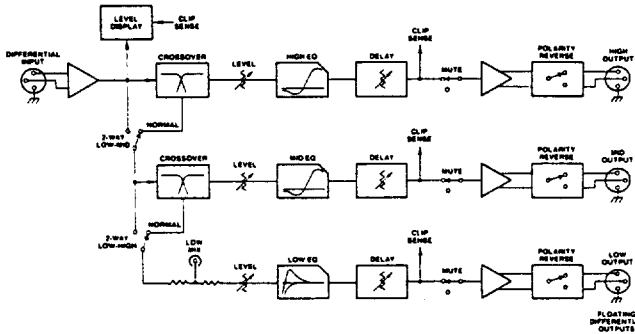

FIGURE 2 — XEQ-3 Crossover Block Diagram

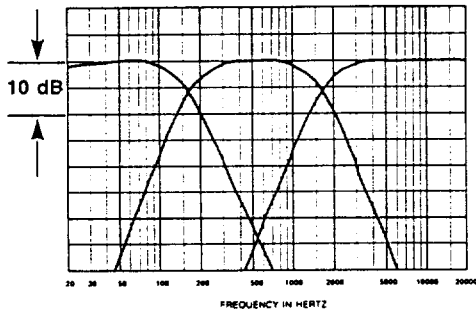

FIGURE 3 — Typical Crossover Curve

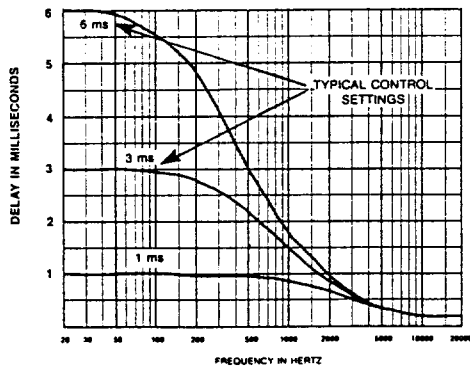

FIGURE 4 — Low-Frequency Time Delay

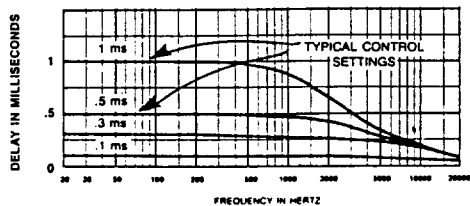

FIGURE 5 — Mid- and High-Frequency Time Delay

SWITCH POSITIONS	OUTPUT RESPONSE
NORMAL (BOTH OUT)	Graph showing two peaks: LOW and HIGH, with a dip in the MID range.
LOW-HIGH	Graph showing a single peak in the MID range, with dips in the LOW and HIGH ranges.
LOW-MID	Graph showing a single peak in the LOW range, with dips in the MID and HIGH ranges.
BOTH IN	Graph showing a single peak in the MID range, with dips in the LOW and HIGH ranges.

FIGURE 6 — Switching for Two-Way Operation

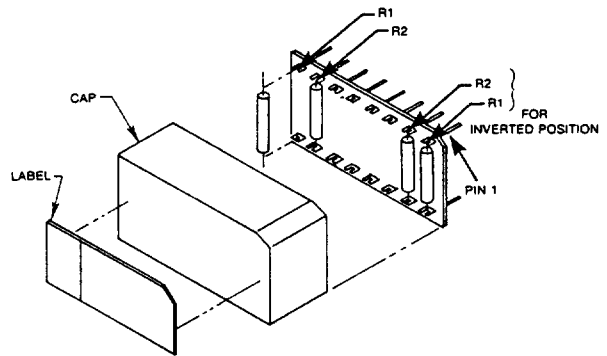

FIGURE 7 — Low-Frequency Equalization Module Assembly

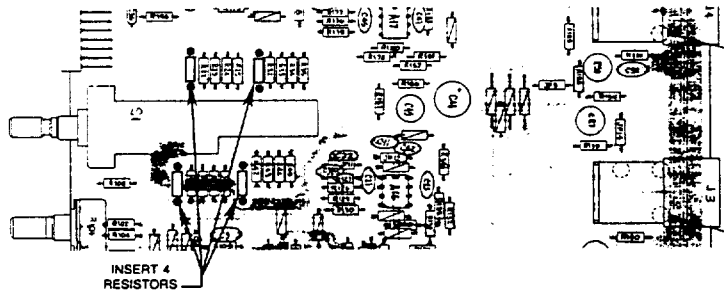

FIGURE 8 — Crossover-Frequency Modification

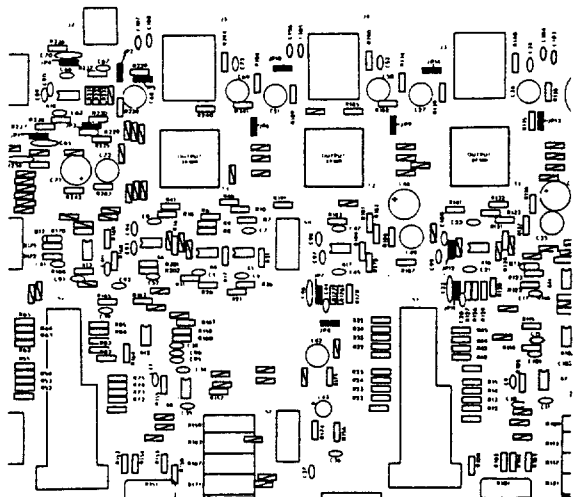

FIGURE 9 — Transformer Mounting Locations. Jumpers to Cut are Shown as Solid Rectangles.

LINKWITZ-RILEY FILTER ADVANTAGES

All contemporary crossover designs maintain predictable acoustic summing in the horizontal plane with vertically aligned system configurations. However, in the vertical plane, common Butterworth designs exhibit a phenomenon termed "lobing error" caused by the 90-degree phase shift of outputs and the 3-dB attenuation at crossover. To explore the implications of lobing error, the following text examines the radiation patterns of systems using a Butterworth filter (Figure 10) and a Linkwitz-Riley filter (Figure 11).

In Figure 10, the cancellation axes result from the same acoustic signal of two physically displaced sources arriving out of phase at discrete locations. Consider a typical system with a horn/driver combination in vertical alignment with a low-frequency system. For locations above or below the system axis, acoustic signals at crossover frequency will arrive from the horn and woofer at different times (due to the path-length differences), resulting in a "phase cancellation" at discrete locations. The peaking axis represents the discrete locations where the two transducers are exactly in phase and combine to produce a +3-dB peak relative to the on-axis level. As phase cancellation is frequency dependent, changing the crossover frequency will alter the axis orientation.

Linkwitz-Riley filters are termed "zero lobing error" because the unavoidable cancellation axes are placed symmetrically above and below the system axis. Also, the system on-axis response is "flat" with no off-axis response peaks.

In Figure 11, the Linkwitz-Riley filter does not eliminate the cancellation axis; again, this is purely a function of two displaced sources reproducing a common frequency. However, from a design standpoint, the lobes are now placed in a much more manageable position—consider a typical system orientation with respect to a seating area. Commonly, the system is aimed near the center of the

seating bank. From Figure 10, it is obvious that a seating section below the system will experience a "hot spot" produced by the peaking lobe of a system using a Butterworth-design crossover filter. Also, a seating area above the system axis will experience a "dropout" caused by the interference along the upper cancellation axis. In contrast, consider the same conditions using a Linkwitz-Riley crossover filter.

With Linkwitz-Riley filter characteristics, there is no peaking axis and, therefore, no "hot spots" referenced to the system axis. In the above example, the Linkwitz-Riley cancellation axes are located at $\pm 30^\circ$ relative to the system. As the vertical coverage pattern of common high-frequency horns is $40^\circ (\pm 20^\circ)$, the cancellation axes are located beyond the designed coverage area in single horn/driver systems. Recall from Figure 10 that one cancellation axis for a Butterworth filter is located within the coverage pattern of typical horns.

From the above examples and illustrations, it clear that Linkwitz-Riley filter characteristics offer the sound-system designer distinct advantages, as opposed to Butterworth designs, for electronic crossovers. In summary, Linkwitz-Riley filters produce no off-axis response peaks and place the inevitable cancellation axes symmetrically above and below the system axis for smoother overall frequency response in the crossover region.

A more detailed and graphic treatment of the subject is available in a number of technical articles, including:

1. S.H. Linkwitz, "Active Crossover Networks for Noncoincident Drivers," *J. Audio Eng. Soc.*, vol. 24, pp. 2-8 (1976 January/February).
2. S.P. Lipshitz and J. Vanderkooy, "A Family of Linear-Phase Crossover Networks of High Slope Derived by Time Delay," *J. Audio Eng. Soc.*, vol. 31 pp. 2-20 (1983 January/February).

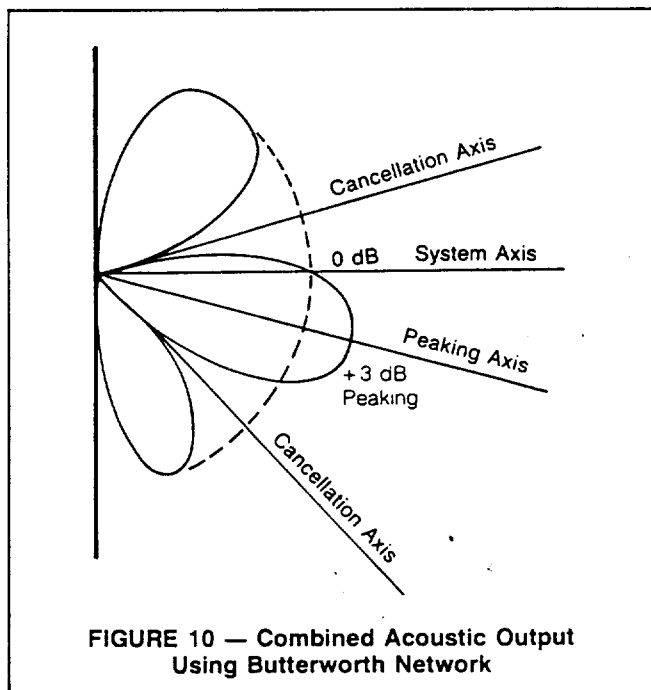

FIGURE 10 — Combined Acoustic Output Using Butterworth Network

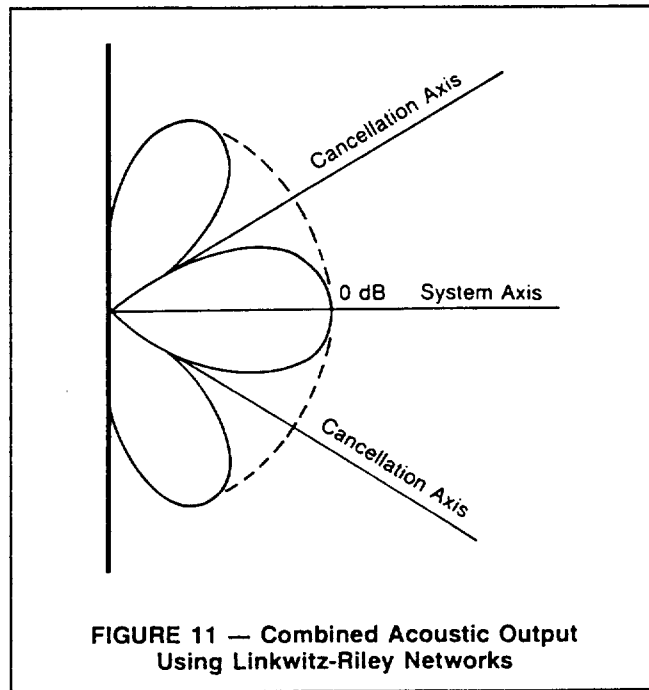
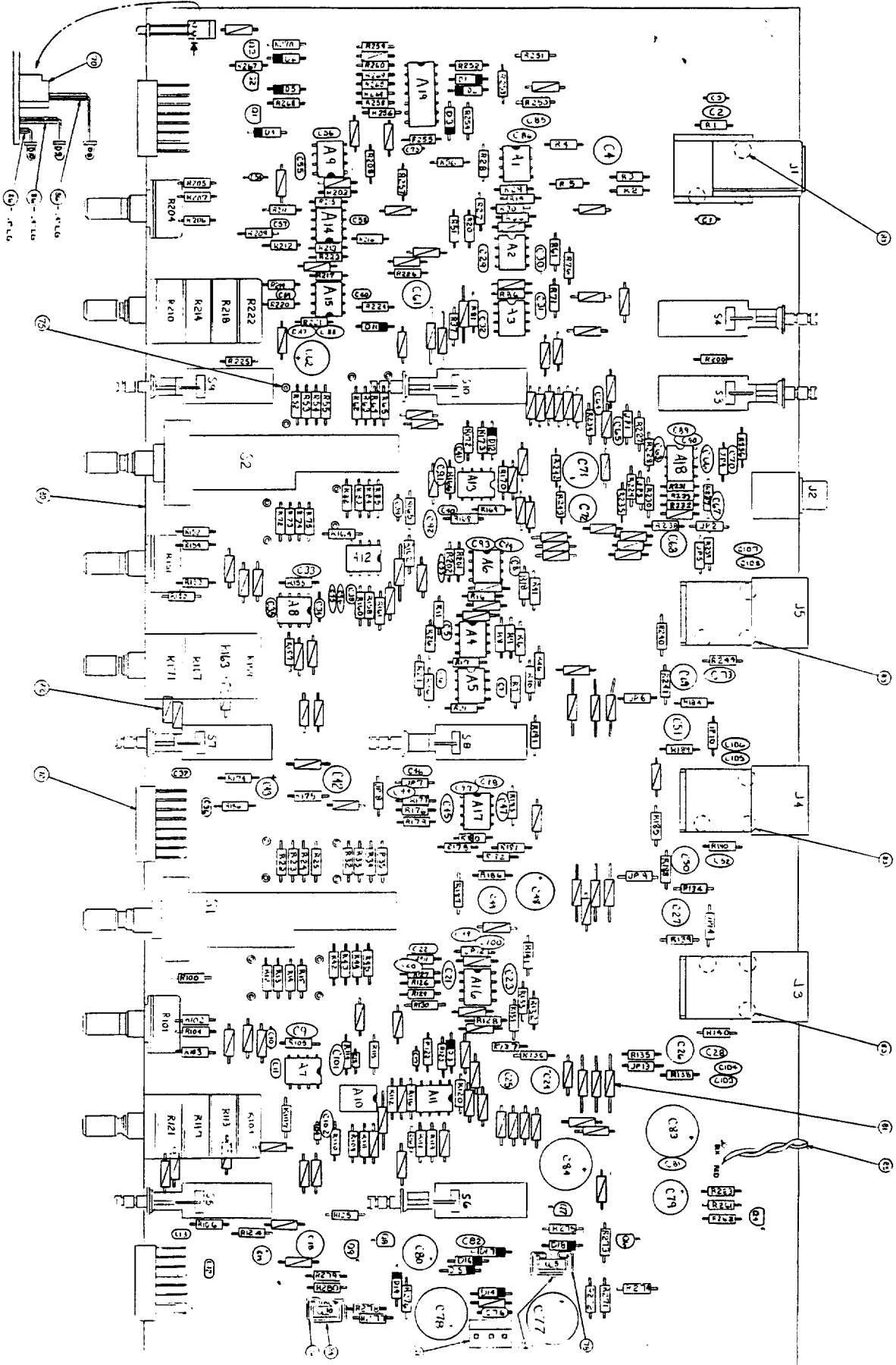
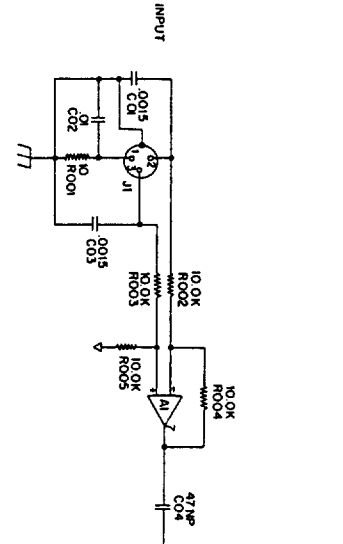

FIGURE 11 — Combined Acoustic Output Using Linkwitz-Riley Networks





HIGH FILTER

- R011, R021, R031, R041 • 2.00K
- R012, R022, R032, R042 • 1.24K
- R013, R023, R033, R043 • 10.7K
- R014, R024, R034, R044 • 16.5K
- R015, R025, R035, R045 • 44.2K
- R016, R026, R036, R046 • 50.1K

LOW FILTER

- R051, R061, R071, R081 • 2.00K
- R052, R062, R072, R082 • 1.27K
- R053, R063, R073, R083 • 5.76K
- R054, R064, R074, R084 • 14.3K
- R055, R065, R075, R085 • 26.7K
- R056, R066, R076, R086 • 17.8K

NOTES:
 1-RESISTORS NOTED ARE PART OF HORN-DRIVER EQ PLUG-IN MODULE.
 (EQ SUPPLIED CONTAINS JUMPERS AT POSITIONS 2 & 7 ONLY)
 2-RESISTORS NOTED ARE PART OF LOW-FREQUENCY EQ OR HIGH-PASS(REVERSIBLE) PLUG-IN MODULES.

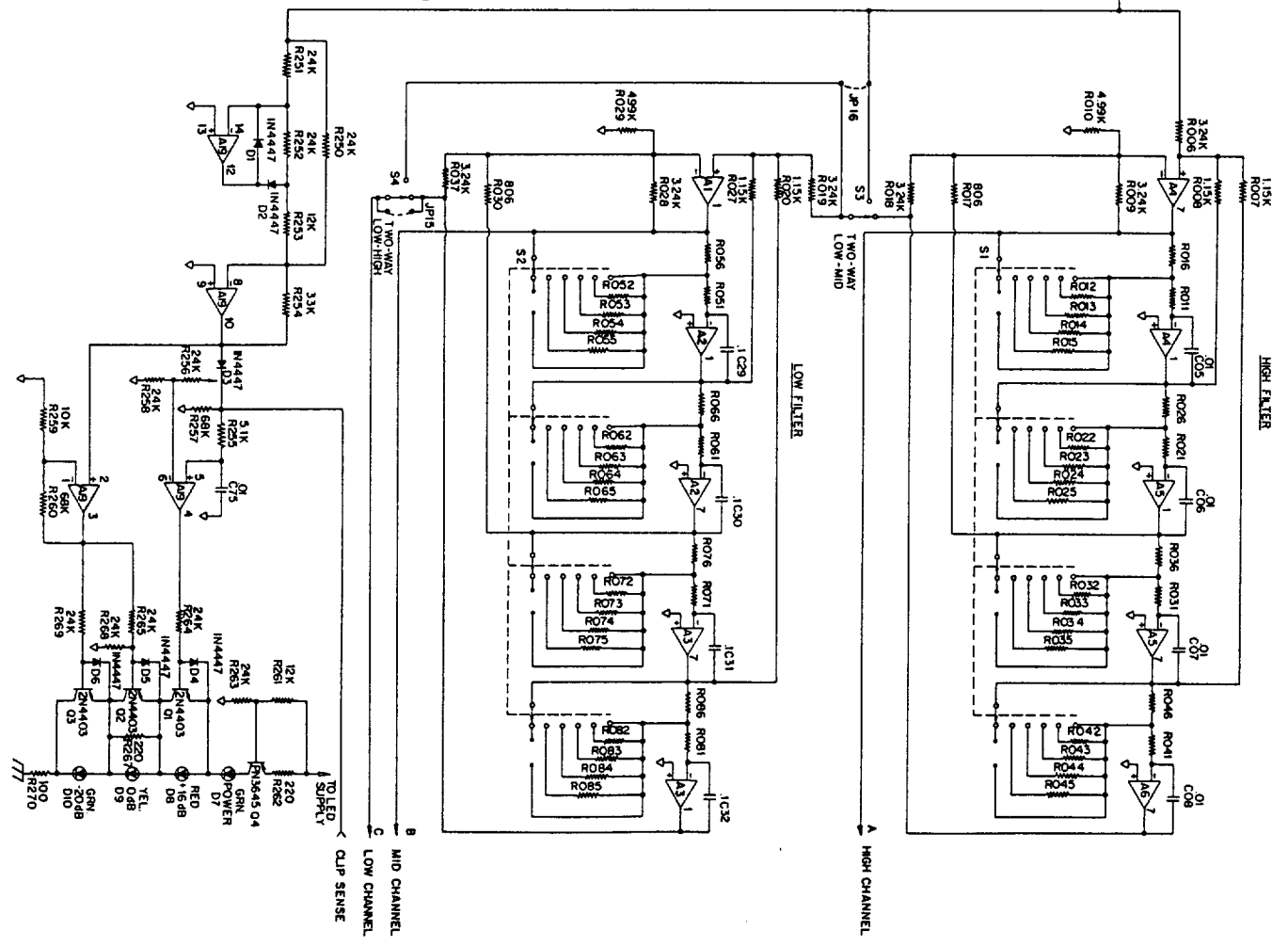

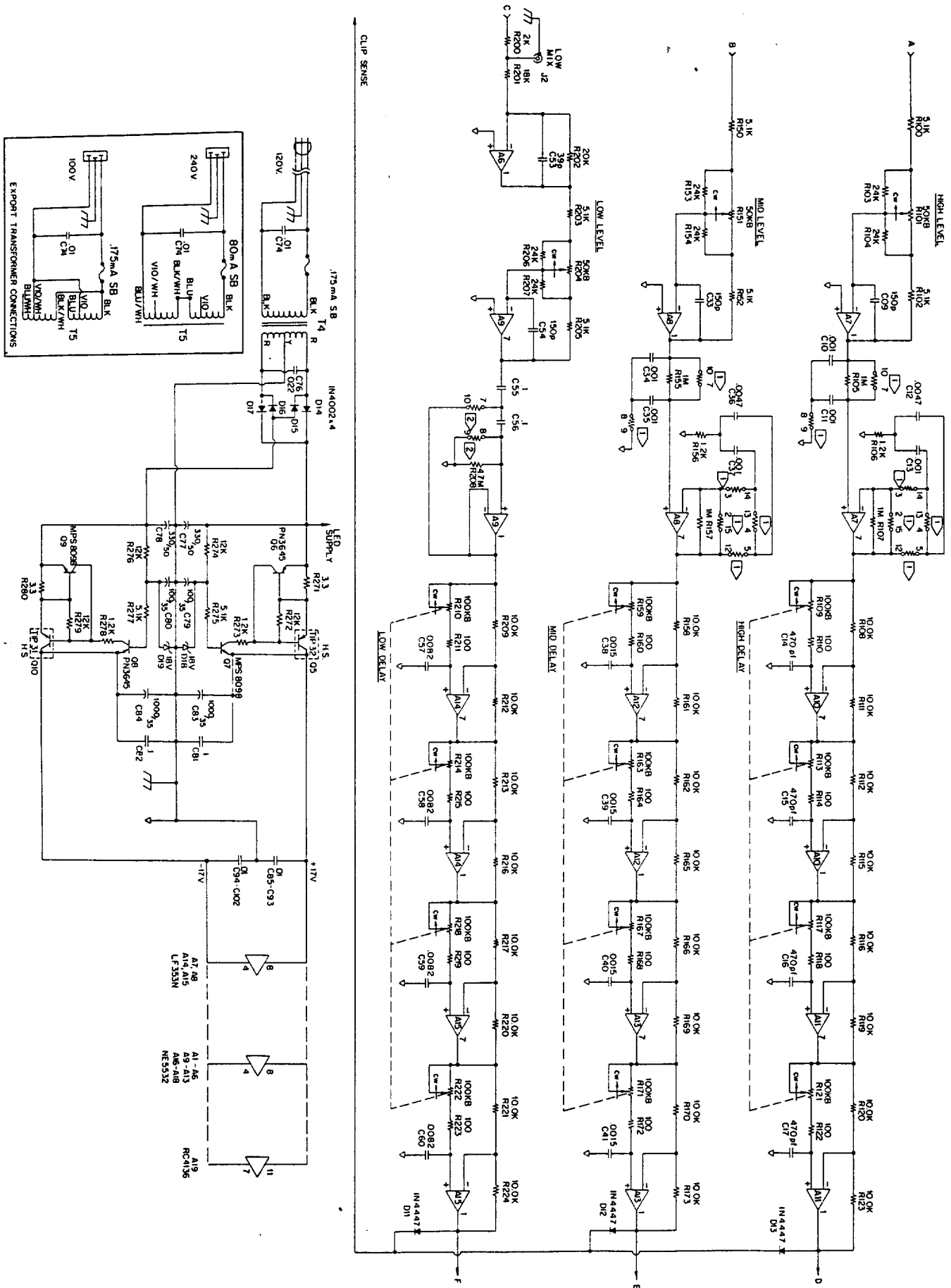

CLIP SENSE

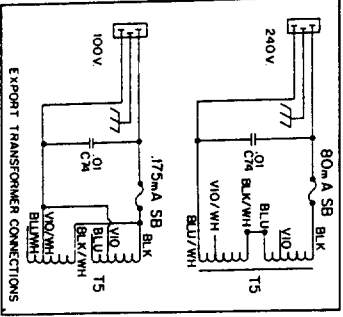

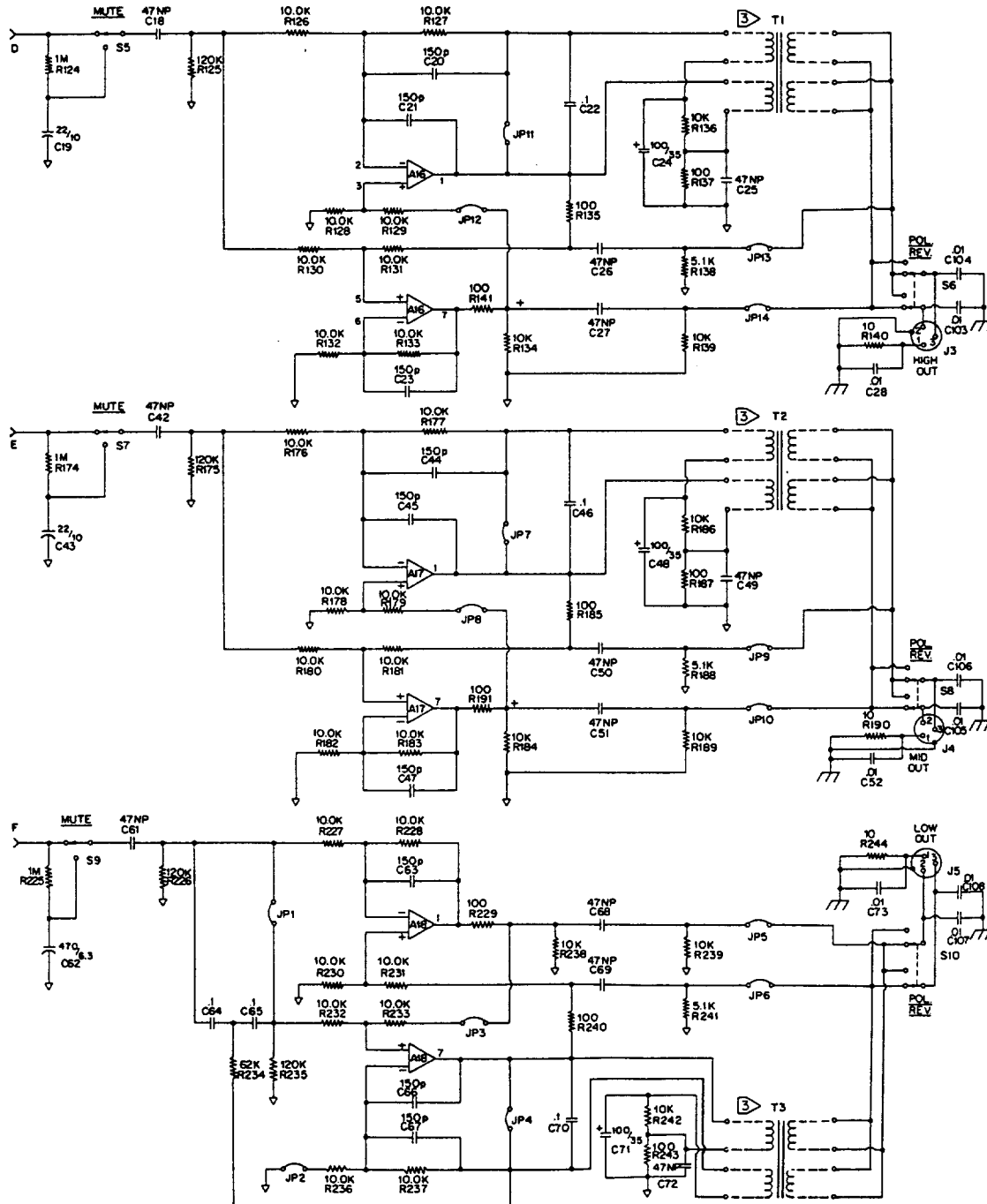

NOTE:
 TRANSFORMERS T1, T2, T3 ARE ACCESSORY ITEMS (CONTAINED IN TRB-2) THAT CAN BE ADDED FOR TRANSFORMER COUPLED OUTPUTS. WHEN ADDED, JUMPERS JP1 THRU JP14 MUST BE REMOVED.

805010	LED & WIRE S/A	D7
500801	RIVET, PDP, BLACK	
500074	SCREW, 4-40 x 1/4, SM PHP, TYPE F, BLK	
454252	TUBING	
452503-2	JUMPER, ZERO OHM, 0.4' LG	
452503	JUMPER, ZERO OHM, 0.6' LG	
451163	PC BOARD	
400065	KNOB, BLACK, ROTARY	
400023	KNOB, BLACK, PUSH SWITCH	
304015	HEATSINK, TO-220, THERMALLOY 6043	
303124	FUSE, 0.8 AMP, SLO-BLOW, 240V	
303122	FUSE, 0.175 AMP, SLO-BLOW	
303066	LINE CORD, SJT (DOMESTIC)	
302118	TRANSFORMER, PDWER (EXPORT VERSIONS)	T5
302117	TRANSFORMER, PGWER (DOMESTIC VERSIONS)	T4
301034	SWITCH, 4P6T, ROTARY, MOBLE SR50346B25KC	SLS2
301023	SWITCH, DPDT, PUSH, ON-OFF	S3-S10
300136	SOCKET, PCB MOUNT, LEAD	
300118	CONNECTOR, MIC MALE, RA, ADC 4-24028-0180	J3-J5 ASI-01-1241640
300113	CONNECTOR, MIC JACK, RA, ADC 4-24027-0150	J1 ASI-01-124170
300101	SOCKET, DIP, 16 PIN, RT ANG, PC MOUNT	
300097	HEADER, 345' SO, 3 PIN W/LOCK, AMP	
300095	CONNECTOR, RECEPTACLE, 2 PIN, AMP	
300090	CONNECTOR, HOUSING, MTS-156, 3 POS	
300020	CONNECTOR, PHONO JACK, RT ANG, SMK S03081	J2
008073	LED, GREEN, GL-211	D10
008072	LED, YELLOW, YL-212	D9
008064	LED, RED, T-1	D8
008049	DIODE, SIGNAL, IN4447	D1-D6, D11-D13
008046	DIODE, ZENER, 18V, IN4746A	D18, D19
008022	DIODE, PDWER, IN4002	D14-D17
007014	I.C., DUAL, QUAD, RC4136	A19
007013	I.C., DUAL, 8 PIN, NE5532	A1-A6, A9-A13, A16-A18
007010	I.C., DUAL, 8 PIN, LF353N	A7, A8, A14, A15
006051	TRANSISTOR, NPN, MFS8090	Q7, Q9
006044	TRANSISTOR, PNP, TIP32	Q5
006043	TRANSISTOR, NPN, TIP31	Q10
006042	TRANSISTOR, PNP, 2N4403	Q1, Q2, Q3
006004	TRANSISTOR, PNP, PN3645	Q4, Q6, Q8
005967	RESISTOR, 4.7 MEG, +/-5%, 1/4 W, C.F.	R208
005951	RESISTOR, 1 MEG, +/-5%, 1/4 W, C.F.	SEE NOTE 12
005928	RESISTOR, 120K, +/-5%, 1/4 W, C.F.	R125, R175, R226, R235
005922	RESISTOR, 68K, +/-5%, 1/4 W, C.F.	R257, R260
005921	RESISTOR, 62K, +/-5%, 1/4 W, C.F.	R234
005914	RESISTOR, 33K, +/-5%, 1/4 W, C.F.	R254
005911	RESISTOR, 24K, +/-5%, 1/4 W, C.F.	SEE NOTE 11
005909	RESISTOR, 20K, +/-5%, 1/4 W, C.F.	R202
PART No.	DESCRIPTION	REFERENCE DES.

BILL OF MATERIAL (CONTINUED)

005908	RESISTOR, 18K, +/-5%, 1/4 W, C.F.	R201
005904	RESISTOR, 12K, +/-5%, 1/4 W, C.F.	SEE NOTE 10
005902	RESISTOR, 10K, +/-5%, 1/4 W, C.F.	SEE NOTE 9
005894	RESISTOR, 5.1K, +/-5%, 1/4 W, C.F.	SEE NOTE 8
005884	RESISTOR, 2 K, +/-5%, 1/4 W, C.F.	R200
005879	RESISTOR, 1.2K, +/-5%, 1/4 W, C.F.	R106, R156, R273, R278
005861	RESISTOR, 220, +/-5%, 1/4 W, C.F.	R262, R267
005853	RESISTOR, 100, +/-5%, 1/4 W, C.F.	SEE NOTE 7
005829	RESISTOR, 10, +/-5%, 1/4 W, C.F.	R1, R140, R190, R244
005817	RESISTOR, 3.3, +/-5%, 1/4 W, C.F.	R271, R280
005621	RESISTOR, 10.0K, +/-1%, 1/4 W, MET FILM	SEE NOTE 6
005513	POTENTIOMETER, 100K, 4 GANG, B TAPER	SEE NOTE 5
005486	POTENTIOMETER, 50K, PCB, B TAPER	R101, R151, R204
005372	RESISTOR, 44.2K, +/-1%, 1/4 W, MET FILM	R15, R25, R35, R45
005371	RESISTOR, 30.1K, +/-1%, 1/4 W, MET FILM	R16, R26, R36, R46
005370	RESISTOR, 26.7K, +/-1%, 1/4 W, MET FILM	R55, R65, R75, R85
005369	RESISTOR, 17.8K, +/-1%, 1/4 W, MET FILM	R56, R66, R76, R86
005368	RESISTOR, 16.5K, +/-1%, 1/4 W, MET FILM	R14, R24, R34, R44
005367	RESISTOR, 14.3K, +/-1%, 1/4 W, MET FILM	R54, R64, R74, R84
005366	RESISTOR, 10.7K, +/-1%, 1/4 W, MET FILM	R13, R23, R33, R43
005365	RESISTOR, 5.76K, +/-1%, 1/4 W, MET FILM	R53, R63, R73, R83
005364	RESISTOR, 4.99K, +/-1%, 1/4 W, MET FILM	R10, R29
005363	RESISTOR, 3.24K, +/-1%, 1/4 W, MET FILM	R6, R9, R18, R19, R28, R37
005362	RESISTOR, 2.00K, +/-1%, 1/4 W, MET FILM	SEE NOTE 4
005361	RESISTOR, 1.27K, +/-1%, 1/4 W, MET FILM	R52, R62, R72, R82
005360	RESISTOR, 1.24K, +/-1%, 1/4 W, MET FILM	R12, R22, R32, R42
005359	RESISTOR, 1.15K, +/-1%, 1/4 W, MET FILM	R7, R8, R20, R27
005358	RESISTOR, 806, +/-1%, 1/4 W, MET FILM	R17, R30
004702	CAPACITOR, 0.01 MFD, 250V, UL APPROVED	C74
004216	CAPACITOR, 47 MFD, 25V, ELEC, NP, RAD	SEE NOTE 3
004087	CAPACITOR, 0.01 MFD +/- 20%, 50V, CER	C2, C28, C52, C73, C85-C108
004084	CAPACITOR, 1500 PF, +/- 10%, 100V, CER	CLC3
004080	CAPACITOR, 150 PF, +/- 10%, 100V, CER	SEE NOTE 2
004022	CAPACITOR, 39 PF, +/- 10%, 50V, CER	C53
003685	CAPACITOR, 470 PF	C14-C17
03330	CAPACITOR, 0.022 MFD, +/-10%, 250V, MYLAR	C76
003273	CAPACITOR, 0.1 MFD, +/- 5%, 50V, MYLAR	SEE NOTE 1
003232	CAPACITOR, 0.01 MFD, +/- 5%, MYLAR	C5-C8, C75
03226	CAPACITOR, 0.0082 MFD, +/-5%, 50V, MYLAR	C57-C60
003225	CAPACITOR, 0.0047 MFD, +/-5%, 50V, MYLAR	C12, C36
003207	CAPACITOR, 0.0015 MFD, +/-5%, 50V, MYLAR	C38-C41
003201	CAPACITOR, 0.001 MFD, +/-5%, 50V, MYLAR	C10, C11, C13, C34, C35, C37
001617	CAPACITOR, 330 MFD, 50V, ELEC, ALUM RAD	C77, C78
001529	CAPACITOR, 1000 MFD, 35V, ELEC, ALUM RAD	C83, C84
001514	CAPACITOR, 100 MFD, 35V, ELEC, ALUM RAD	C24, C48, C71, C79, C80
001209	CAPACITOR, 22 MFD, 10V, ELEC, ALUM RAD	C19, C43
001121	CAPACITOR, 470 MFD, 6.3V, ELEC, ALUM RAD	C62
PART No.	DESCRIPTION	REFERENCE DES.

BILL OF MATERIAL FOR ONE COMPLETE UNIT

NOTES :

1. P/N 003273 REF. DES. : C22, C29-C32, C46, C55, C56, C64, C65, C70, C81, C82
2. P/N 004080 REF. DES. : C9, C20, C21, C23, C33, C44, C45, C47, C54, C63, C66, C67
3. P/N 004216 REF. DES. : C4, C18, C25-C27, C42, C49-C51, C61, C68, C69, C72
4. P/N 005362 REF. DES. : R11, R21, R31, R41, R51, R61, R71, R81
5. P/N 005513 REF. DES. : R[109, 113, 117, 121], R[159, 163, 167, 171], R[210, 214, 218, 222]
6. P/N 005621 REF. DES. : R2-R5, R108, R111, R112, R115, R116, R119, R120, R123
R126-R133, R158, R161, R162, R165, R166, R169, R170, R173,
R176-183, R209, R212, R213, R216, R217, R220, R221, R224,
R227, R228, R230-R233, R236, R237
7. P/N 005853 REF. DES. : R110, R114, R118, R122, R135, R137, R141, R160, R164, R168
R172, R185, R187, R191, R211, R215, R219, R223, R229, R240,
R243, R270
8. P/N 005894 REF. DES. : R100, R102, R138, R150, R152, R188, R203, R205, R241, R255,
R275, R277
9. P/N 005902 REF. DES. : R134, R136, R139, R184, R186, R189, R238, R239, R242, R259
10. P/N 005904 REF. DES. : R253, R261, R272, R274, R276, R279
11. P/N 005911 REF. DES. : R103, R104, R153, R154, R206, R207, R250-R252, R256, R258,
R263-R265, R268, R269
12. P/N 005951 REF. DES. : R105, R107, R124, R155, R157, R174, R225
13. FOR SCHEMATIC SEE EV DRAWING NUMBER 301-11.

REPAIR PARTS

Service parts are available from the Redmond factory. Contact us by phone or mail.

Our address: Electro-Voice, Inc.
3810 148th Ave. NE
Redmond, WA 98052

206/881-9555
(8AM-4PM pacific time zone)

If you are ordering parts and do not have the six digit part number, please include the model and serial number of the unit, the assembly part number and revision. The assembly part number/revision is a six digit, one letter code beginning with 800 that is rubber stamped on the parts side of the PCB assembly. In lieu of this information, the two digit, one letter code etched into the foil side of the PCB is helpful. If you are ordering a control or switch, tell us the function name . . . power, frequency, input level, etc.

In any event, be sure to include the following information:

Your Name
Shipping address (no post office boxes, please)
City, State, Zip
Daytime phone number
Method of shipment (UPS ground if not specified)

If you call us for assistance on/with a problem, please have the EXACT model number, serial and assembly part numbers handy.

WARRANTY (Limited)

Electro-Voice Professional Sound Reinforcement Electronic Components are guaranteed for two years from date of original purchase against malfunction due to defects in workmanship and materials. If such malfunction occurs, unit will be repaired or replaced (at our option) without charge for materials or labor if delivered prepaid to the proper Electro-Voice service facility. Unit will be returned prepaid. Warranty does not extend to finish, appearance items or malfunction due to abuse or operation under other than specified conditions, nor does it extend to incidental or consequential damages. Some states do not allow the exclusion or limitation of incidental or consequential damages, so the above exclusion may not apply to you. Repair by other than Electro-Voice or its authorized service agencies will void this guarantee. A list of authorized service centers is available from Electro-Voice, Inc., 600 Cecil Street, Buchanan, MI 49107 (AC/616-695-6831); Electro-Voice, Inc., 3810 148th Avenue N.E., Redmond, WA 98052 (AC/206-881-9555); and/or Electro-Voice West, 8234 Doe Avenue, Visalia, CA 93291 (AC/209-651-7777). This warranty gives you specific legal rights, and you may also have other rights which vary from state to state.

Service and repair address for this product:
Electro-Voice, Inc., 3810 148th Avenue N.E., Redmond, Washington 98052.

Specifications subject to change without notice.

PROPRIETARY NOTICE

This document and the technical data hereon disclosed, are proprietary to Electro-Voice, Inc. and shall not, without express written permission of Electro-Voice, Inc. be used, released or disclosed in whole or in part, or used to solicit quotations from a competitive source or used for manufacture by anyone other than Electro-Voice, Inc. The information hereon has been developed at private expense, and may only be used for purposes of engineering evaluation and for incorporation into technical specifications and other documents which specify parts procured by or procurement of products from Electro-Voice, Inc.



ELECTRO-VOICE, INC., 600 Cecil Street, Buchanan, Michigan 49107

MANUFACTURING PLANTS AT ■ BUCHANAN, MI ■ NEWPORT TN ■ SEVIERVILLE TN ■ REDMOND, WA ■ GANANOQUE, ONT
©Electro-Voice, Inc. 1986 ■ Litho In U.S.A.

a gulton company

Form 2569