



Electro-Voice® R200 SERIES WIRELESS

OWNER'S MANUAL



TABLE OF CONTENTS

DESCRIPTION	3
R200 SERIES COMPONENTS	3
QUICK SETUP AND USE	4-5
COMPATIBILITY	6
POTENTIAL SOURCES OF INTERFERENCE	6
BATTERY RECOMMENDATIONS	6
SPECIFICATIONS	7
FCC REGULATIONS	8
WARRANTY	8
IN CASE OF DIFFICULTY	9

R200 SERIES OWNER'S MANUAL

System Features

- True-diversity system with Secure-Phase™ ensures maximum range and freedom from interference
- Well-designed companding and audio circuitry insure high signal-to-noise ratio and excellent sound quality
- Choice of handheld, bodypack, lavalier, headset and guitar systems
- Permanently attached antennas make setup quick and easy. Receivers may be rack-mounted with optional kit.
- Audio output via 3-pin XLR-type balanced mic level and ¼-inch unbalanced line level connectors
- Designed and manufactured in the United States of America

DESCRIPTION

The Electro-Voice R200 is a series of UHF wireless systems that combine EV's legendary quality, reliability and high value. The R200 Series transmitters and receivers operate in the UHF frequency range between 710.100 and 721.350 MHz (channels 54-55 in the TV band) on single frequencies. The well-designed audio circuitry ensures excellent signal-to-noise ratio with accurate sound quality.

SECURE-PHASE™ DIVERSITY

The R200 Series receivers utilize patented Secure-Phase™ diversity circuitry that provides the strongest, cleanest signal possible. Unlike other diversity circuits that switch antennas, Secure-Phase™ utilizes the signal from both antennas at all times to increase signal strength, minimize dropouts and lower the potential for interference.

If the signal from the transmitter changes phase or polarity (a common cause of dropouts), the circuit adjusts the phase angle between the two antennas receiving circuits to prevent cancellation.

R200 SERIES COMPONENTS

R200 Secure-Phase™ Diversity UHF Receivers

- Secure-Phase™ diversity for maximum range and reliability
- Clean, undistorted sound reproduction using proprietary compander circuitry
- Audio output via rear-mounted XLR-type 3-pin mic level or front-mounted, adjustable line level ¼-inch connector
- May be rack mounted with optional kit

- External AC power adapter minimizes noise and makes voltage changes easy if necessary. Power can also be supplied from a 12-volt battery or filtered power supply.
- Permanently attached, specially-tuned antennas are easy to position
- **RCU:** UHF receiver specially designed to reproduce all the nuances of the voice
- **GRU:** UHF guitar receiver specially designed to handle the transients of a guitar

The R200 Series receivers are easy to set up and operate. The only controls are the adjustable output level and squelch controls. The antennas are permanently attached telescoping types that are easy to position and are tuned to the range of operation. An optional rack-mount kit allows two systems to be mounted in a single rack space.

HTU Handheld Transmitter

- Electro-Voice BK-1 (HTUC) cardioid condenser microphone transducer or Electro-Voice N/D157 (HTUD) cardioid N/DYM dynamic transducer.
- Separate LEDs for power on and battery status for easy monitoring of operational modes.
- Separate power and audio mute switches for operational flexibility.
- Wide-range gain control allows approximately 40 dB of adjustment.
- Special "soft-touch" finish and ergonomically designed handle makes holding comfortable and secure.
- Up to 10 hours of operation on a 9-volt alkaline battery.

Bodypack Transmitters

- Two models are available:
- **BPU:** UHF bodypack with TA4F connector allows the user the freedom of microphone selection. Standard microphones include the Electro-Voice ULM20 cardioid condenser lavalier microphone and the HM2 headset microphone. The TA4F connector allows connection of any dynamic or condenser microphone that can be biased with 5 volts dc phantom.
- **BGU:** UHF guitar bodypack with hardwired cable and ¼-inch connector with specially designed audio circuitry to handle guitar transients
- Separate on/off and large mute switches for operational flexibility
- **LED battery condition indicator gives quick indication of battery strength**

- Up to 10 hours of operation on a 9-volt alkaline battery

QUICK SETUP AND USE

To get your system into operation quickly, use the following instructions. Review the rest of the manual for additional setup and operational details.

1. Place the receiver where there is a clear line of sight to the area where the transmitter will be used (Figure 1). Extend the receiver's antennas and separate them 90 degrees (see Figure 2).
2. Make sure the sound system's volume is low or off on the input you intend to use for the wireless.
3. Plug in the receiver's power adapter into an AC outlet and the other end into the receiver. **CAUTION: Please make sure that the AC adapter is the correct voltage for your local requirements.**
4. Plug the audio cable (not supplied) into either output connector. The 3-pin XLR-type con-

necter is the preferred choice since the output is balanced. Either connector may be used with good results.

5. Turn the output level control (see Figure 2) on the front panel to the 12:00 o'clock position (midway in the control's range) if the 1/4-inch connector is used (the 3-pin XLR-type connector has fixed level).
6. Setup and adjust the transmitter level as described on the following pages.
7. Turn up the level on the mixer or preamp to the desired setting.
8. Speak into the microphone or strum the instrument and, if necessary, adjust the receiver's output until the volume level from the wireless system approximates the level of an equivalent wired microphone or instrument.
9. "Walk" the expected area of use to check for dropouts or interference. If problems occur, see the troubleshooting section.

Figure 1

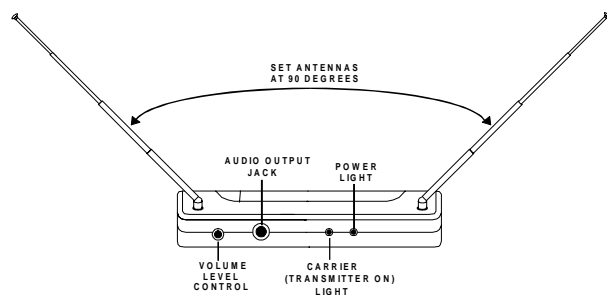

HTU HANDHELD TRANSMITTER SETUP

1. **Insert battery.** Slide open the battery compartment cover by placing your thumb on the indents of the battery door (at the back end of the transmitter) and gently pull down (see Figure 3).
2. **Turn on the transmitter** by sliding the power switch (closest to the battery compartment) forward to its on position, toward the mic element. The red battery condition light should flash once and then go out. If the red LED stays on or illuminates during a performance, it should be replaced immediately. The green LED will stay lit when the transmitter is on.
3. **Check reception.** Observe that the audio carrier light on the front panel of the receiver is illuminated, an indication that the receiver is picking up the signal. Then, "walk" the intended area of use and make sure that there are no barriers to reception or sources of interference.

4. **Unmute the audio** by sliding the audio switch (immediately below the mic element) towards the windscreen.
5. **Adjust the gain if necessary.** First, speak or sing into the microphone and listen closely for distortion or hiss. If the gain is too low or high, adjustments are necessary. Gently insert the provided screwdriver (or other 3/32-in. screwdriver) into the hole near the head of the transmitter (see Figure 4). Turn lightly until the screwdriver tip drops into the slot in the level control. Gently turn counterclockwise until the control stops (the mic output is attenuated but not "off"). Slowly turn the mic-level control while listening to the audio. If the audio becomes distorted, turn the mic level control counter-clockwise about 1/8 turn.
6. **Adjust the squelch control if necessary.** The squelch control on the back of the receiver may be adjusted to increase range or reduce interference. Turn the control counter-

clockwise to increase range. **Caution! Increasing the range will make the system more susceptible to outside interference!** If the squelch is being adjusted, turn the

transmitter off. Turn the squelch control counter-clockwise until you hear noise or interference. Then, turn the squelch clockwise until the noise is gone.

Figure 2

BODYPACK TRANSMITTER SETUP

- 1. Insert battery.** Open the hinged battery compartment by placing your thumb or finger on the indent on the battery door and pull down. When inserting the battery, pay attention to the polarity (+/-) and insert the terminals into the battery compartment first. Close the battery door by sliding the door shut.
- 2. Turn on the transmitter** by sliding the power switch to its on position. Check the condition of the battery by looking at the LED below the power switch. The red battery light should flash once and then go out. If the LED stays on, the battery is weak and should be replaced.
- 3. Prepare the audio source** by attaching the lavalier microphone to the user, placing the headset on the user's head or plugging the cable into the instrument (depending on what type of system you have). **Keep the audio muted while plugging in and adjusting the microphone or source.** Placement of lavalier and headset microphones will noticeably change the sound quality, so some experimentation with the user is necessary.

- 4. Check reception** by observing that the RF carrier light is illuminated on the receiver's front panel.
- 5. Turn on the audio transmission** by sliding the large mute switch to the "on" position.
- 6. Listen carefully to the audio** and be sensitive of overload distortion and low gain or hiss.
- 7. Adjust the gain if necessary.** Gently insert the provided screwdriver or other 3/32-in. (2.5 mm) screwdriver into the gain adjustment located at the top edge of the battery compartment under the door. The door has to be opened but not swung upward to make adjustments. Turn lightly until the screwdriver tip drops into the slot on the level control. Gently turn the control counterclockwise until the control stops (the audio output is attenuated but not "off"). Slowly turn the audio level control clockwise while listening to audio; if the audio becomes distorted, turn the mic level control counter-clockwise about 1/8 turn.
- 8. Clip the bodypack to the user's belt or to a pocket.** The bodypack can be positioned horizontally or vertically by moving the belt clip attachment. Removing the belt clip attachment screw and moving it 90 degrees will change the orientation.

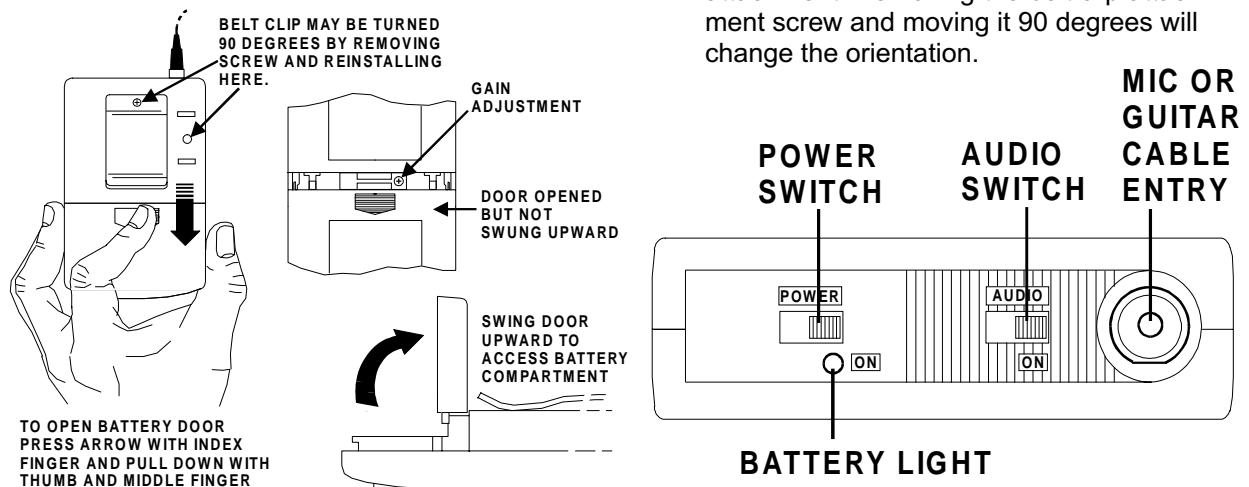

COMPATIBILITY

The receiver and transmitter must be on the same UHF frequency to operate together. Because of the specialized equipment required to adjust these units properly, users cannot change the frequencies or make any internal adjustments.

If two or more R200 and/or other VHF/UHF wireless systems are being used in the same location, proper frequency coordination is necessary to avoid interference. Frequency mixing and spacing must be factored along with local TV stations to determine if conflicts will result from a specific group. Contact your dealer or Electro-Voice for frequency-selection assistance if you are planning to add more wireless systems to be operated simultaneously in the same location.

POTENTIAL SOURCES OF INTERFERENCE

There are many potential sources of interference for your wireless system. Any electronic compo-

nent that contains digital circuitry including digital signal processors (reverb/multi-effects units), electronic keyboards, digital lighting controllers, CD players and computers all emit rf energy that can affect the performance of your wireless system. It is always best to place your receiver as far away from these devices as possible to minimize this potential source of problems.

BATTERY RECOMMENDATIONS

Fresh 9-volt alkaline batteries from a quality manufacturer will yield the best performance from R200 transmitters. 8.4-volt ni-cad batteries can be used but will yield much shorter operational time. When the transmitter switch is turned on, the battery light will flash one time if the battery is good. If the light does not flash or stays lit continuously, the battery is weak or dead. If the light comes on during use, the battery is weakening and should be replaced as soon as possible.

R200 SYSTEM SPECIFICATIONS

SPECIFICATIONS**RCU and GRU Receivers****Receiver Type**

Single-frequency, single-conversion
superheterodyne FM

Frequency Range (RF)

710.100 – 721.350 MHz

Available Frequencies:

710.100; 714.200; 714.700;
715.100; 716.200; 719.700;
720.350; 721.350 MHz

Diversity

True Diversity with Secure-Phase™

RF Sensitivity

< .8 uV for 12 dB SINAD

FCC Data

Approved under part 15

Audio Output,**Frequency Response**

20 – 15 kHz + 2 dB

Audio Output Level

0.775V RMS @ 100 K ohm load

Distortion

Less than 0.5%

Signal-to-Noise Ratio

>94 dB

Dynamic Range

94 dB

UHF Transmitters HTUC, HTUD, BPU, BGU**RF Frequency Range**

710.100 – 721.350 MHz

Radiated RF Output

35-45 mW typical, 50 mW maximum

Microphone Element (HTUC handheld)

Electro-Voice BK-1 cardioid condenser

Microphone Element (HTUD handheld)

Electro-Voice N/D157 cardioid N/DYM

Standard Bodypack Microphones**Lavalier:**

Electro-Voice ULM20 cardioid condenser

Headset:

Electro-Voice HM2 cardioid condenser

TA4F Connector Wiring:

Pin 1: Ground; Pin 2: Mic Input;

Pin 3: +5 volt bias;

Pin 4: +5 volt bias fed through a
3 K ohm resistor for 2-wire electrets

Audio Gain Adjustment Range

40 dB

Battery Life

8 – 10 hours with 9-Volt alkaline

Bodypack Antenna

Utilizes microphone cable

Size (Handheld transmitter)

27.3 cm (10.75 in) long

Size (Bodypack transmitter) HxWxD

4.5 in x 2.6 in x 1.25 in (no antenna)

114.3 x 66.04 x 31.75 mm

Accessories:

OLM10 Omni lavalier mic w/windscreen and clip

450563 Windscreen for OLM10

300059000 Clip for OLM10

ULM20 Unidirectional lavalier mic, windscreen
and clip

879155 ULM20 windscreen

879156 ULM20 clip

HM2 Unidirectional headset condenser mic

450124 Spring-adjusted mic stand adapter

RMR Rack-mount kit for two receivers

Optional Accessories:

RMR Rack-mount kit

PSRUS 120-volt power supply

(730123-1)

PSRER 230-volt power supply

PSRBR 240-volt power supply

FCC REGULATIONS

The Electro-Voice Models HTUC, HTUD, BGU and BPU Transmitters are Type Accepted under United States Federal Communications Commission Part 74H. The Electro-Voice Models RCU and GRU Receivers are accepted under the Part 15 Notification Procedure of the Federal Communications Commission. Licensing of Electro-Voice equipment is the user's responsibility and license ability depends on upon the user's classification, and frequency selected. Electro-Voice urges the user to contact the appropriate telecommunications authority before ordering frequencies other than factory preset frequencies.

CAUTION: Changes or modifications made by the user could void the user's authority to operate the equipment.

Factory Service

If factory service is required, ship the unit prepaid in its original carton to:

EVI Audio Service

600 Cecil Street

Buchanan, MI 49107

Tel: 616/695-6831 • Fax: 616-695-1304

Telex Communications

8601 E. Cornhusker Highway

Lincoln, NE 68506

Tel: 402/467-5321 • Fax: 402/467-3279

Enclose a note describing the problem along with any other pertinent information.

WARRANTY (Limited)

Electro-Voice products are guaranteed against malfunction due to defects in materials or workmanship for a specified period, as noted in the individual product-line statement(s) below, or in the individual product data sheet or owner's manual, beginning with the date of original purchase. If such malfunction occurs during the specified period, the product will be repaired or replaced (at our option) without charge. The product will be returned to the customer prepaid. **Exclusions and Limitations:** The Limited Warranty does not apply to: (a) exterior finish or appearance; (b) certain specific described in the individual product-line statement(s) below, or in the individual product data sheet or owner's manual; (c) malfunction resulting from use or operation of the product other than as specified in the product data sheet or owner's manual; (d) malfunction resulting from misuse or abuse of the product; or (e) malfunction occurring at any time after repairs have been made to the product by anyone other than Electro-Voice or any of its authorized service representatives. Obtaining Warranty Service: To obtain warranty service, the customer must deliver the product, prepaid, to Electro-Voice or any

of its authorized service representatives together with proof of purchase of the product in the form of a bill of sale or receipted invoice. A list of authorized service representatives is available from Electro-Voice at 600 Cecil Street, Buchanan, MI 49107 (616/695-6831 or 800/234-6831). **Incidental and Consequential Damages Excluded:** Product repair or replacement and return to the customer are the only remedies provided to the customer. Electro-Voice shall not be liable for any incidental or consequential damages including, without limitation, injury to persons or property or loss of use. Some states do not allow the exclusion or limitation of incidental or consequential damages so the above limitation or exclusion may not apply to you. **Other Rights:** This warranty gives you specific legal rights and you may also have other rights which vary from state to state.

Electro-Voice Wireless Systems are guaranteed against malfunction due to defects in materials or workmanship for a period of one (1) year from the date of original purchase. The Limited Warranty does not extend to cables or cable connectors. Additional details are included in the Uniform Limited Warranty Statement.

Service and repair addresses for this product::

Telex Communications

8601 East Cornhusker Highway

Lincoln, Nebraska 68506 (402/467-5321) and

Electro-Voice

600 Cecil Street

Buchanan, Michigan 49107

(616/695-6831 or 800-234-6831).

IN CASE OF DIFFICULTY

Problem	Possible Causes	Solutions
No audio	Transmitter audio switch is off.	Turn on transmitter audio switch.
	Disconnected or damaged receiver audio cable	Connect, repair, or replace cable.
	Transmitter power switch is off.	Turn transmitter power switch on, with level down on mixer/preamp/amplifier.
	Receiver is off.	Turn on receiver.
	No (or dead) battery in transmitter.	Insert a fresh alkaline battery into transmitter battery compartment (Duracell MN 1604 recommended).
	Faulty battery contacts in transmitter.	Clean contacts.
Low gain/ volume	Gain down on mixer/preamp/amplifier.	Increase mixer/preamp/amplifier gain.
	Gain not sufficiently on mixer/preamp/ amplifier input.	Increase mixer/preamp/amplifier gain.
	Receiver audio too low.	Increase receiver audio.
Distortion	Transmitter audio level too low.	Turn up transmitter audio level.
	Transmitter audio level too high, overloading transmitter circuit.	Turn down transmitter audio level.
	Receiver audio set too high, overloading the mixer/preamp/amplifier input.	Turn down receiver audio level.
Signal interference	Battery level low in transmitters.	Insert fresh battery.
	Another wireless microphone in the immediate vicinity operating on the same frequency, or on a frequency that mixes with another transmitter (such as a TV broadcast transmitter) onto the wireless frequency.	If interference is weak, keep transmitter on to override interference whenever receiver is on (or "fade audio on mixer/preamp/ amplifier). If interference is strong, turn off all other wireless in area to find the one causing the problem.
	Placement too close to a digital signal processor or similar device.	Move receiver to another location.
	Strong electromagnetic field from stage lighting or other source near the transmitter or receiver, producing "rf noise" on or near the operating frequency of the wireless system.	Repair or remove source of interference.
Short-range or frequent drop-outs	Faulty receiving antenna system.	Reposition antennas or receiver.
	Faulty transmitter antenna.	Return to factory or authorized service station.
	Many rf-reflective metal obstacles between the transmitter and receiver.	Move the obstacles or reposition the receiver.

INSTALLATION FOR RECEIVER RACK MOUNT KIT

R-Series wireless receivers can be rack mounted with the optional RMR kit. The RMR allows two receivers to be mounted side-by-side in a single rack space.

Attach Bracket to Receiver

1. Fold antennas down and insert the R-Series receiver through the rectangular cut-out as shown.
2. Align the two holes in the bottom of each receiver with the two holes in the bracket. Secure the receiver to the bracket with the 2 #6 Plastite screws provided.

Mounting the Bracket/Receiver on a Rack

1. Secure the bracket to the rack with the 4, 10-32 x 3/8" screws provided.
2. Fold the antennas up and extend fully. The antennas should be folded 45 from vertical and should not touch the antenna on the adjacent receiver, or any other metal object.
3. Follow the Equipment Set-up procedures as outlined in the R-Series receiver instruction manual for proper set-up and operation of your wireless microphone system.

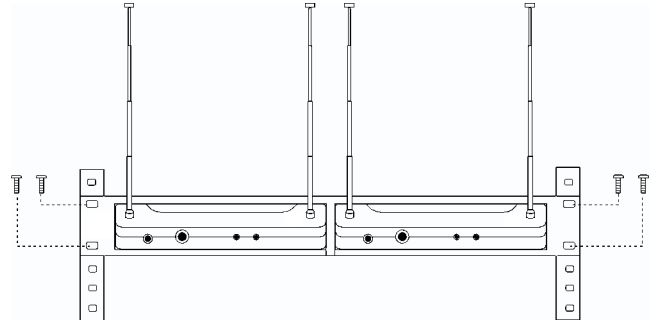
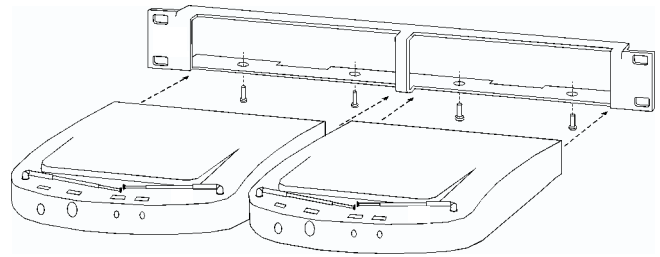

Electro-Voice[®]

600 Cecil Street, Buchanan, MI 49107
800/234-6831, 616/695-6831, 616/695-1304 Fax