

**ALTEC
LANSING**

TELEX/EVI Audio
600 Cecil Street
Buchanan, Michigan 49107
Phone: 616-695-6831
FAX: 616-695-4743

**SERVICE
DATA**

ALX SERIES

RECONE INSTRUCTIONS

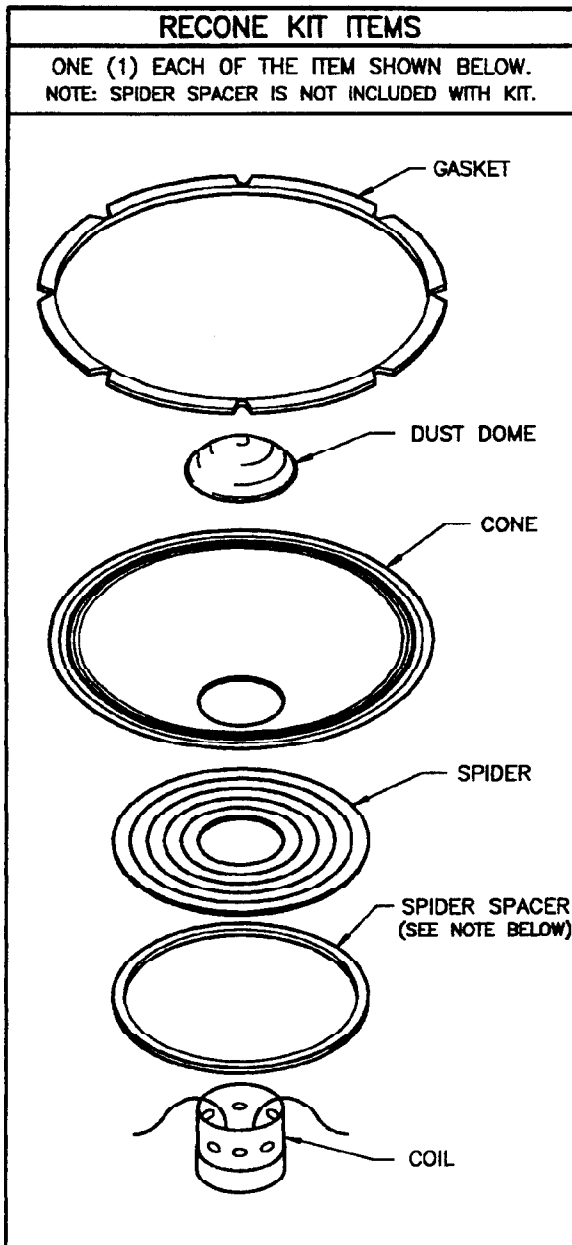

FIGURE 1

NOTE: ONLY EARLY VERSIONS HAD SPIDER SPACERS. IF YOUR LOUDSPEAKER HAS ONE, IT ALSO MUST BE REPLACED AND HAS TO BE ORDERED SEPARATELY.

TOOLS REQUIRED	
CENTERING FIXTURE	
SOLDERING IRON	
SHARP KNIFE	
PHILLIPS SREWDRIWER	
CHISEL	
1/2" WIDE PAINT BRUSH	
HEAT GUN (OPTIONAL)	
HEAT LAMP (OPTIONAL)	
TESTING EQUIPMENT REQUIRED	
SINE WAVE GENERATOR	
200-WATT (OR GREATER) POWER AMPLIFIER	
AC VOLTMETER	
OHMMETER	
ADHESIVES REQUIRED	
(SEE ADHESIVE APPLICATION SHEET FOR PROPER ADHESIVE)	
A	EPOXY HARDENER
	EPOXY RESIN
B	RUBBER CEMENT
C	DAMPING COMPOUND
D	DUST DOME CEMENT
CURING DATA	
EPOXY (A):	
TIME: OVERNIGHT (8-HOURS)	
HEAT: UNTIL SOLID + ALLOW TO SET 1/2 HR.	
RUBBER CEMENT (B):	
ALLOW TO SET UP. NO HEAT. (1/2-HOUR)	
SPIDER/DUST DOME CEMENT (D):	
ALLOW TO SET UP. NO HEAT. (1-HOUR)	

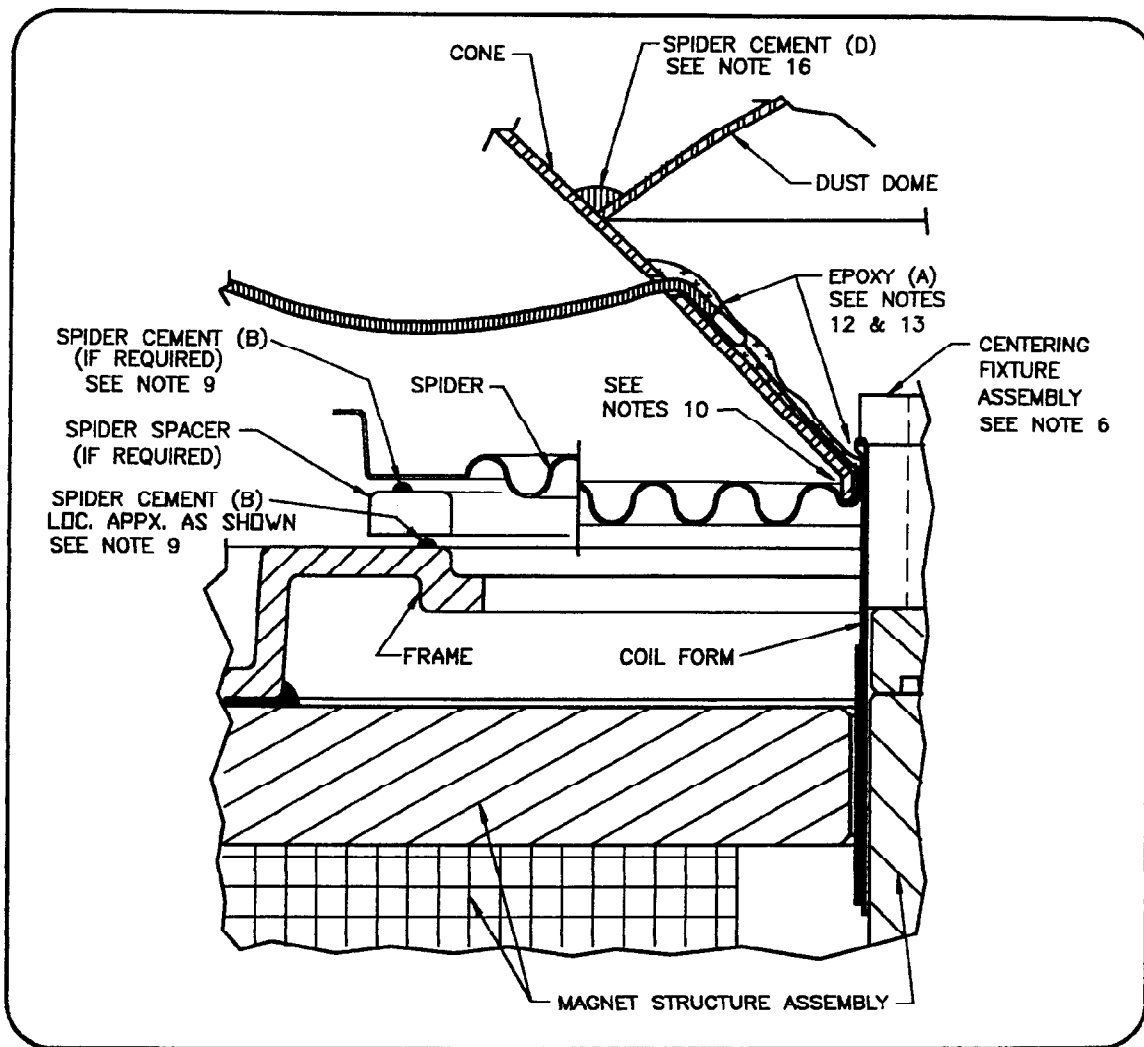

FIGURE 2

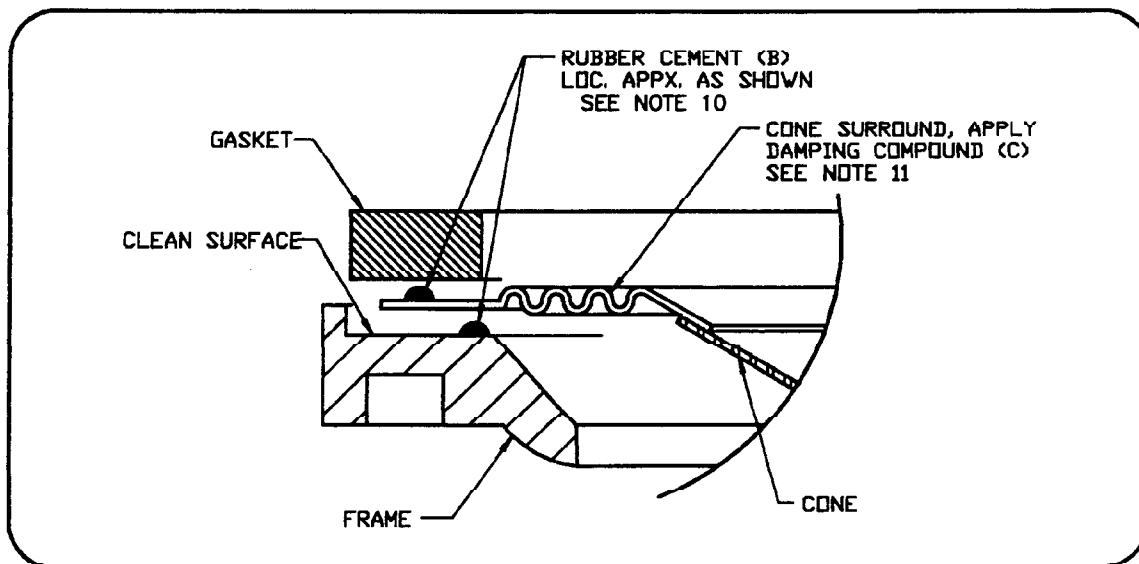

FIGURE 3

INSTRUCTIONAL AND CAUTIONAL NOTES

A CRITICAL POINT EXISTS WHERE THE COIL LEADS COME OFF THE COIL FORM. EXERCISED CARE AT ALL TIMES NOT TO ACCIDENTALLY BEND A COIL LEAD.

CHECK CONE LIP FOR FIT OVER COIL FORM AND SPIDER LIP. THE CONE LIP MUST EASILY SET OVER THE LIP OF THE SPIDER. IF NECESSARY, ENLARGE THE CONE LIP I.D.

NOTE: DO NOT ENLARGE THE SPIDER LIP.

PUNCH TWO SMALL HOLES IN THE SPEAKER CONE FOR THE COIL LEAD WIRES. LOCATE THESE HOLES 1" APART AND 1" UP FROM THE CONE LIP.

RECONE INSTRUCTIONS

1. REMOVE AND DISCARD THE OLD GASKET.
2. REMOVE THE OLD CONE, SPIDER, SPIDER SPACER (IF PRESENT) AND VOICE COIL, BY CUTTING ALONG THE OUTSIDE PERIMETER OF THE CONE AND SPIDER. CUT BOTH LEADS WIRES AND DISCARD OLD PARTS.
3. PLACE TAPE OVER AIRGAP TO KEEP OUT DEDRIS.
4. USE A CHISEL TO REMOVE ANY EXCESS ADHESIVE WHERE THE CONE AND SPIDER WERE ATTACHED. HEATING THE AREA WITH A HEAT GUN WILL SIMPLIFY THIS OPERATION. BE CAREFUL NOT TO GET DEDRIS INTO THE MAGNETIC GAP. VACUUM THE SPEAKER TO REMOVE ALL DEDRIS.
5. REMOVE TAPE THAT WAS PUT OVER AIRGAP AND REMOVE ANY PARTICLES FROM THE MAGNETIC GAP BY USING A PIECE OF FOLDED MASKING TAPE.
6. SLIDE THE COIL FORM ASSEMBLY OVER THE MYLAR SHIM ON THE CENTERING FIXTURE (SEE FIGURE 4) UNTIL THE TOP OF THE COIL FORM TOUCHES THE TAPE ON THE FIXTURE.
7. PUT THE COIL LEAD WIRES INTO THE I.D. OF THE CENTERING FIXTURE AND CAREFULLY SLIP THE NEW SPIDER OVER THE CENTERING FIXTURE ASSEMBLY.
8. IF A SPIDER SPACER IS REQUIRED, THE I.D. AND O.D. MUST BE COATED WITH BLACK CP MOYEN CONE AND GASKET CEMENT.
9. PLACE A GENEROUS BEAD OF SPIDER CEMENT (B) ALONG THE INNER EDGE OF THE SPEAKER FRAME (SEE FIGURE 2). POSITION THE SPIDER SPACER (IF REQUIRED) ONTO THE INNER EDGE OF THE FRAME. PLACE ANOTHER GENEROUS BEAD OF SPIDER CEMENT (B) ON TOP OF THE SPIDER SPACER (IF REQUIRED). PROPERLY SEAT THE SPIDER ON TOP OF THE FRAME (OR SPIDER SPACER).
10. PLACE A GENEROUS BEAD OF CEMENT (B) ALONG THE INNER EDGE OF THE FRAME BASKET AS SHOWN IN FIGURE 3. POSITION THE SPEAKER CONE BY FIRST ALIGNING THE LEAD WIRE HOLES WITH THE SPEAKER TERMINALS AND THEN SLIP THE CONE OVER THE COIL/CENTERING FIXTURE ASSEMBLY AND LET THE INSIDE LIP OF THE CONE REST ON THE SPIDER AS SHOWN IN FIGURE 2. PROPERLY SEAT THE CONE SURROUND TO THE SPEAKER FRAME.
10. CONT'D
PLACE ANOTHER GENEROUS BEAD OF CEMENT (B) AROUND THE TOP SURFACE OF THE CONE SURROUND AND PROPERLY POSITION THE NEW GASKET AND SECURE IN PLACE (SEE FIGURE 3). PLACE A WEIGHT (OR SECOND SPEAKER) ON TOP OF THE GASKET FOR UNIFORM CURING OF THE CEMENT.
11. APPLY DAMPING COMPOUND (C) ONTO THE SURROUND SECTION OF THE CONE, FROM THE INSIDE DIAMETER OF THE GASKET TO APPX. 1" DOWN ON THE CONE PASSED THE I.D. EDGE OF THE SURROUND SECTION.
12. PUSH THE FREE END OF THE TENSEL LEAD WIRES THROUGH THE HOLES IN THE CONE. PUSH THE COIL WIRES AGAINST THE OUTSIDE OF THE COIL FORM AND AGAINST THE CONE SURFACE UP TO THE WIRE HOLE. BRIDGE THE LEAD WIRES AWAY FROM THE CONE, LEAVING A SMALL AMOUNT OF SLACK IN THE WIRE AND SOLDER THE WIRES TO THE TERMINAL LUGS. TRIM EXCESS WIRE.
13. APPLY EPOXY (A) BETWEEN THE CONE AND THE COIL LEAD WIRE UP TO THE WIRE HOLE AND SEAL HOLE. APPLY EPOXY (A) COMPLETELY AROUND THE CORNER FORMED BY THE CONE, SPIDER AND COIL FORM (SEE FIGURE 2).
CAUTION: BE CAREFUL NOT TO GLUE THE COIL FORM TO THE MYLAR SHIM OF THE CENTERING FIXTURE DURING ANY POINT OF THIS STEP.
14. CURE EPOXY AND SPIDER CEMENT.
15. AFTER CURING, REMOVE THE CENTERING FIXTURE FROM THE POT ASSEMBLY.
16. POSITION THE DUST DOME AND USE A LIGHT WEIGHT TO HOLD THE DOME IN PLACE. APPLY A BEAD OF CEMENT (D) AROUND THE EDGE OF THE DOME, BETWEEN THE DOME AND THE CONE.

TESTING INSTRUCTIONS

1. APPLY A 25 VOLT, 20 Hz SINE WAVE TO THE INPUT TERMINAL FOR ONE MINUTE. THE SPEAKER SHOULD NOT BOTTOM. THIS WOULD BE INDICATED BY A LOUD STRIKING NOISE.
2. APPLY A 10 VOLT SINE WAVE TO THE INPUT TERMINALS AND SWEEP FROM 20 Hz TO 2 KHz. THERE SHOULD BE NO RUBS, BUZZES OR SPURIOUS NOISES.

MYLAR SHIM (SHOWN IN FLAT)

NOTE: DETAILS ARE NOT SHOWN TO SCALE

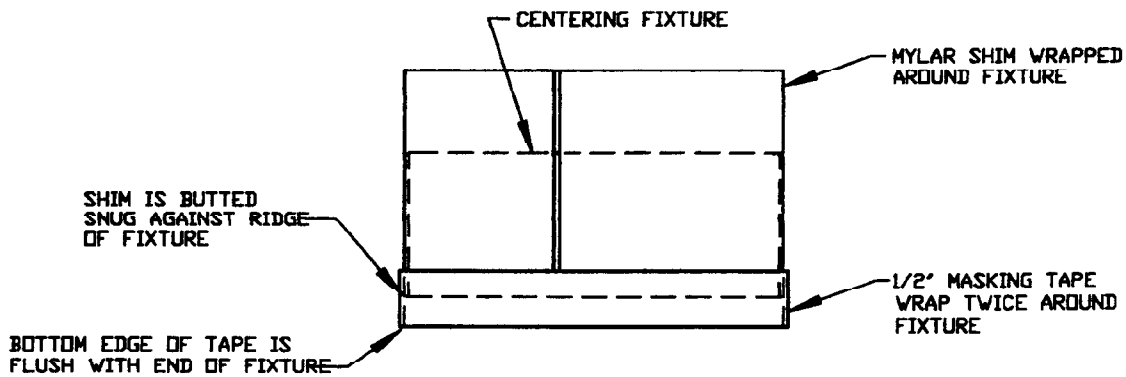

FIGURE 4

CONE FORM CENTERING FIXTURE

SPECIAL CARE MUST BE TAKEN IN PREPARING THE ASSEMBLY. WRAP THE MYLAR SHIM AROUND THE FIXTURE, FITTING IT SNUG AGAINST THE RIDGE ON THE FIXTURE. SECURE THE SHIM IN POSITION BY USING 1/2 INCH WIDE MASKING TAPE, WRAPPING THE TAPE AROUND THE FIXTURE SLEEVE TWICE. TAPE MUST BE FLUSH WITH THE END OF FIXTURE SLEEVE.

ALTEC LANSING CAN SUPPLY BOTH THE COIL FORM CENTERING FIXTURE AND THE SPECIAL MYLAR SHIM.

**ALTEC
LANSING**

TELEX/EVI Audio
600 Cecil Street
Buchanan, Michigan 49107
Phone: 616-695-6831
FAX: 616-695-4743

**SERVICE
DATA**

DTS 200 WOOFER

RECONE INSTRUCTIONS

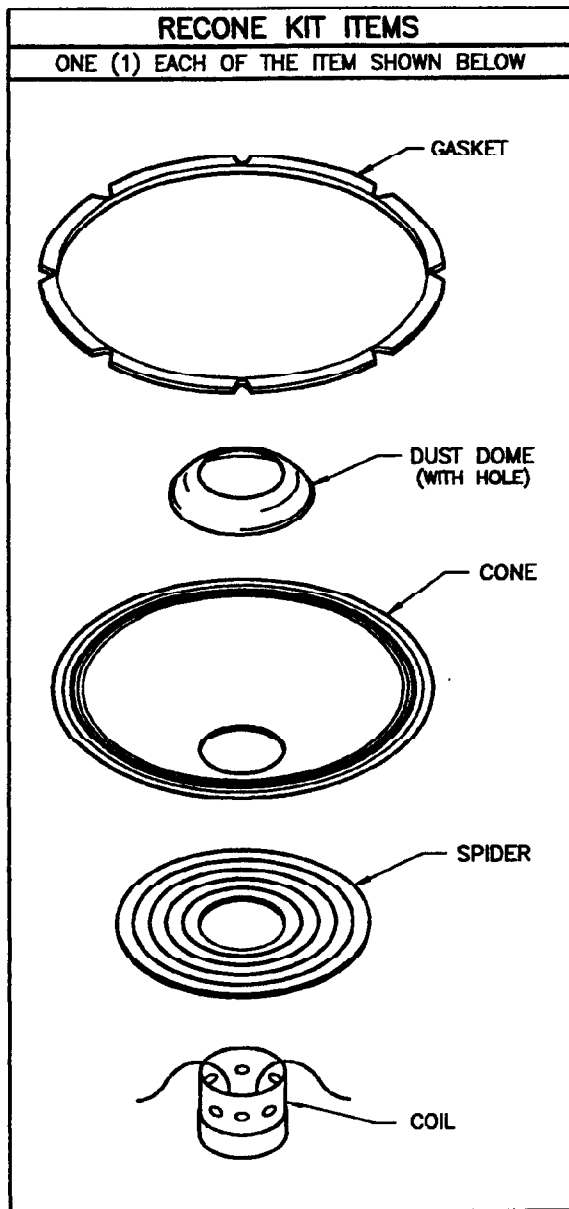

FIGURE 1

TOOLS REQUIRED	
CENTERING FIXTURE	
SOLDERING IRON	
SHARP KNIFE	
PHILLIPS SREWDRIWER	
CHISEL	
1/2" WIDE PAINT BRUSH	
HEAT GUN (OPTIONAL)	
HEAT LAMP (OPTIONAL)	
TESTING EQUIPMENT REQUIRED	
SINE WAVE GENERATOR	
200-WATT (OR GREATER) POWER AMPLIFIER	
AC VOLTMETER	
OHMMETER	
ADHESIVES REQUIRED	
(SEE ADHESIVE APPLICATION SHEET FOR PROPER ADHESIVE)	
A	EPOXY HARDENER
	EPOXY RESIN
B	RUBBER CEMENT
C	DAMPING COMPOUND
D	DUST DOME CEMENT
CURING DATA	
EPOXY (A):	
TIME: OVERNIGHT (8-HOURS)	
HEAT: UNTIL SOLID + ALLOW TO SET 1/2 HR.	
RUBBER CEMENT (B):	
ALLOW TO SET UP. NO HEAT. (1/2-HOUR)	
SPIDER/DUST DOME CEMENT (D):	
ALLOW TO SET UP. NO HEAT. (1-HOUR)	

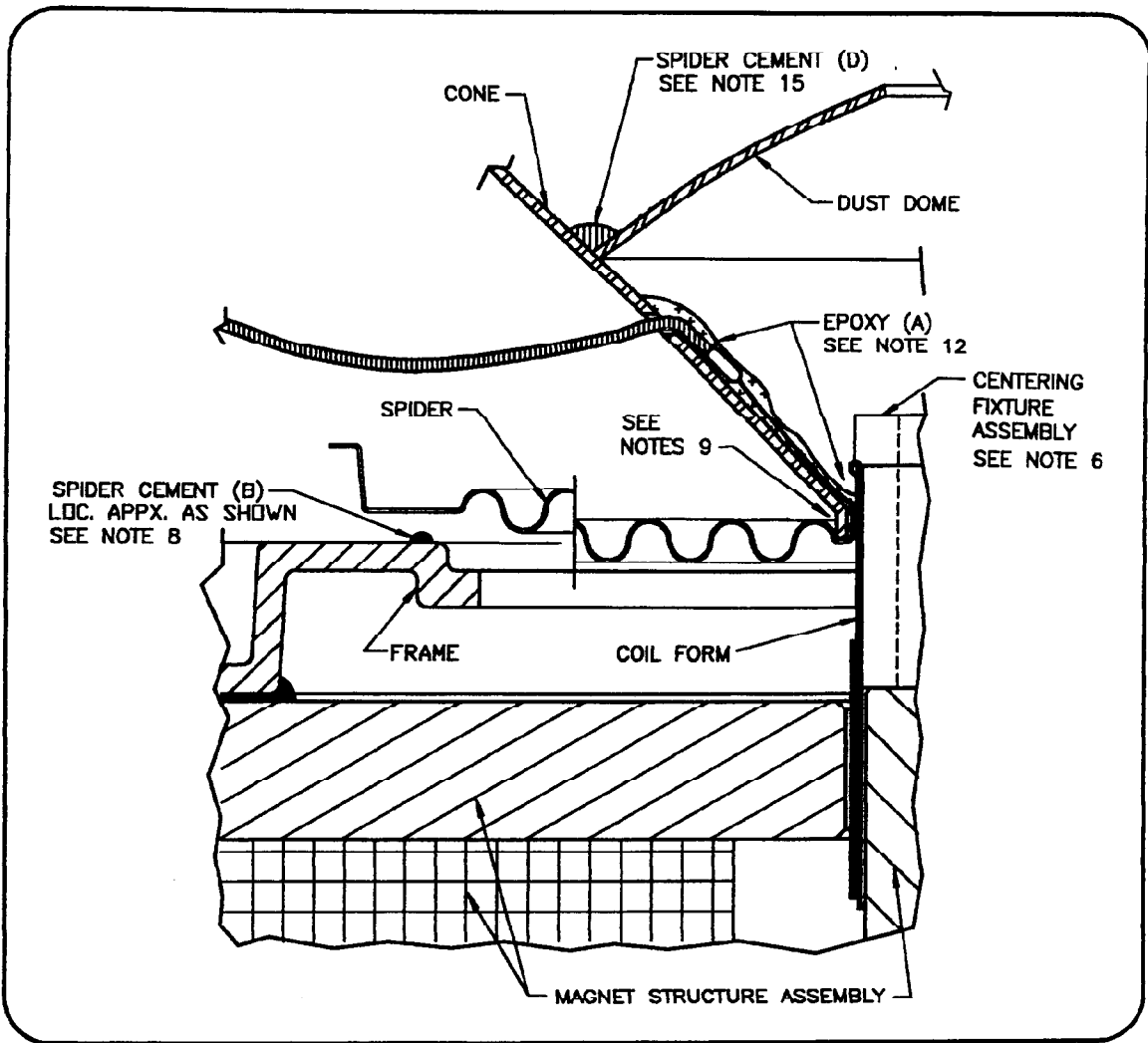

FIGURE 2

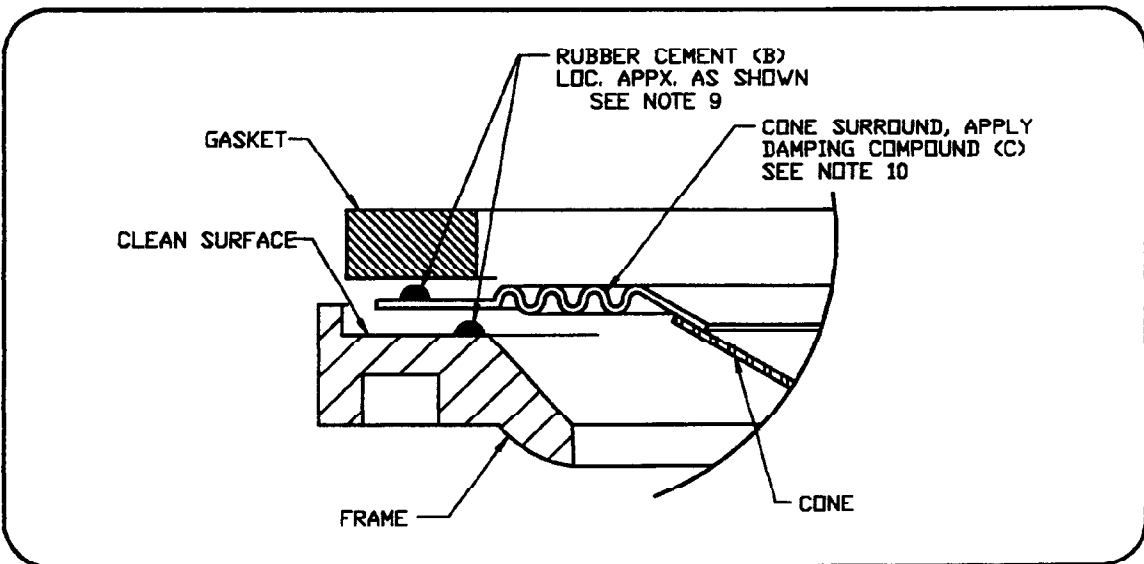

FIGURE 3

INSTRUCTIONAL AND CAUTIONAL NOTES

A CRITICAL POINT EXISTS WHERE THE COIL LEADS COME OFF THE COIL FORM. EXERCISED CARE AT ALL TIMES NOT TO ACCIDENTALLY BEND A COIL LEAD.

CHECK CONE LIP FOR FIT OVER COIL FORM AND SPIDER LIP. THE CONE LIP MUST EASILY SET OVER THE LIP OF THE SPIDER. IF NECESSARY, ENLARGE THE CONE LIP I.D.

NOTE: DO NOT ENLARGE THE SPIDER LIP.

PUNCH TWO SMALL HOLES IN THE SPEAKER CONE FOR THE COIL LEAD WIRES. LOCATE THESE HOLES 1" APART AND 1" UP FROM THE CONE LIP.

RECONE INSTRUCTIONS

1. REMOVE (2) SCREWS HOLDING HORN AND REMOVE HORN. THEN REMOVE AND DISCARD THE OLD GASKET.
2. REMOVE THE OLD CONE, SPIDER AND VOICE COIL, BY CUTTING ALONG THE OUTSIDE PERIMETER OF THE CONE AND SPIDER. CUT BOTH LEAD WIRES AND DISCARD OLD PARTS.
3. PLACE TAPE OVER AIRGAP TO KEEP OUT DEDRIS.
4. USE A CHISEL TO REMOVE ANY EXCESS ADHESIVE WHERE THE CONE AND SPIDER WERE ATTACHED. HEATING THE AREA WITH A HEAT GUN WILL SIMPLIFY THIS OPERATION. BE CAREFUL NOT TO GET DEDRIS INTO THE MAGNETIC GAP. VACUUM THE SPEAKER TO REMOVE ALL DEDRIS.
5. REMOVE TAPE THAT WAS PUT OVER AIRGAP AND REMOVE ANY PARTICLES FROM THE MAGNETIC GAP BY USING A PIECE OF FOLDED MASKING TAPE.
6. SLIDE THE COIL FORM ASSEMBLY OVER THE MYLAR SHIM ON THE CENTERING FIXTURE (SEE FIGURE 4) UNTIL THE TOP OF THE COIL FORM TOUCHES THE TAPE ON THE FIXTURE.
7. PUT THE COIL LEAD WIRES INTO THE I.D. OF THE CENTERING FIXTURE AND CAREFULLY SLIP THE NEW SPIDER OVER THE CENTERING FIXTURE ASSEMBLY.
8. PLACE A GENEROUS BEAD OF SPIDER CEMENT (B) ALONG THE INNER EDGE OF THE SPEAKER FRAME (SEE FIGURE 2). PROPERLY SEAT THE SPIDER.
9. PLACE A GENEROUS BEAD OF CEMENT (B) ALONG THE INNER EDGE OF THE FRAME BASKET AS SHOWN IN FIGURE 3. POSITION THE SPEAKER CONE BY FIRST ALIGNING THE LEAD WIRE HOLES WITH THE SPEAKER TERMINALS AND THEN SLIP THE CONE OVER THE COIL/CENTERING FIXTURE ASSEMBLY AND LET THE INSIDE LIP OF THE CONE REST ON THE SPIDER AS SHOWN IN FIGURE 2. PROPERLY SEAT THE CONE SURROUND TO THE SPEAKER FRAME.
9. CONT'D
PLACE ANOTHER GENEROUS BEAD OF CEMENT (B) AROUND THE TOP SURFACE OF THE CONE SURROUND AND PROPERLY POSITION THE NEW GASKET AND SECURE IN PLACE (SEE FIGURE 3). PLACE A WEIGHT (OR SECOND SPEAKER) ON TOP OF THE GASKET FOR UNIFORM CURING OF THE CEMENT.
10. APPLY DAMPING COMPOUND (C) ONTO THE SURROUND SECTION OF THE CONE, FROM THE INSIDE DIAMETER OF THE GASKET TO APPX. 1" DOWN ON THE CONE PASSED THE I.D. EDGE OF THE SURROUND SECTION.
11. PUSH THE FREE END OF THE TENSEL LEAD WIRES THROUGH THE HOLES IN THE CONE. PUSH THE COIL WIRES AGAINST THE OUTSIDE OF THE COIL FORM AND AGAINST THE CONE SURFACE UP TO THE WIRE HOLE. BRIDGE THE LEAD WIRES AWAY FROM THE CONE, LEAVING A SMALL AMOUNT OF SLACK IN THE WIRE AND SOLDER THE WIRES TO THE TERMINAL LUGS. TRIM EXCESS WIRE.
12. APPLY EPOXY (A) BETWEEN THE CONE AND THE COIL LEAD WIRE UP TO THE WIRE HOLE AND SEAL HOLE. APPLY EPOXY (A) COMPLETELY AROUND THE CORNER FORMED BY THE CONE, SPIDER AND COIL FORM (SEE FIGURE 2).
CAUTION: BE CAREFUL NOT TO GLUE THE COIL FORM TO THE MYLAR SHIM OF THE CENTERING FIXTURE DURING ANY POINT OF THIS STEP.
13. CURE EPOXY AND SPIDER CEMENT.
14. AFTER CURING, REMOVE THE CENTERING FIXTURE FROM THE POT ASSEMBLY.
15. POSITION THE DUST DOME. MAKE SURE THE HOLE IN THE DOME IS PROPERLY CENTERED AND WILL NOT CONTACT THE HORN WHEN IT IS RE-INSTALLED. USE A LIGHT WEIGHT TO HOLD THE DOME IN PLACE. APPLY A BEAD OF CEMENT (D) AROUND THE EDGE OF THE DOME, BETWEEN THE DOME AND THE CONE.
CAUTION: VISUALLY CHECK DOME/HOLE POSITION WITH HORN PRIOR TO APPLYING CEMENT.

TESTING INSTRUCTIONS

1. APPLY A 25 VOLT, 20 Hz SINE WAVE TO THE INPUT TERMINAL FOR ONE MINUTE. THE SPEAKER SHOULD NOT BOTTOM. THIS WOULD BE INDICATED BY A LOUD STRIKING NOISE.
2. APPLY A 10 VOLT SINE WAVE TO THE INPUT TERMINALS AND SWEEP FROM 20 Hz TO 2 KHz. THERE SHOULD BE NO RUBS, BUZZES OR SPURIOUS NOISES.

MYLAR SHIM (SHOWN IN FLAT)

NOTE: DETAILS ARE NOT SHOWN TO SCALE

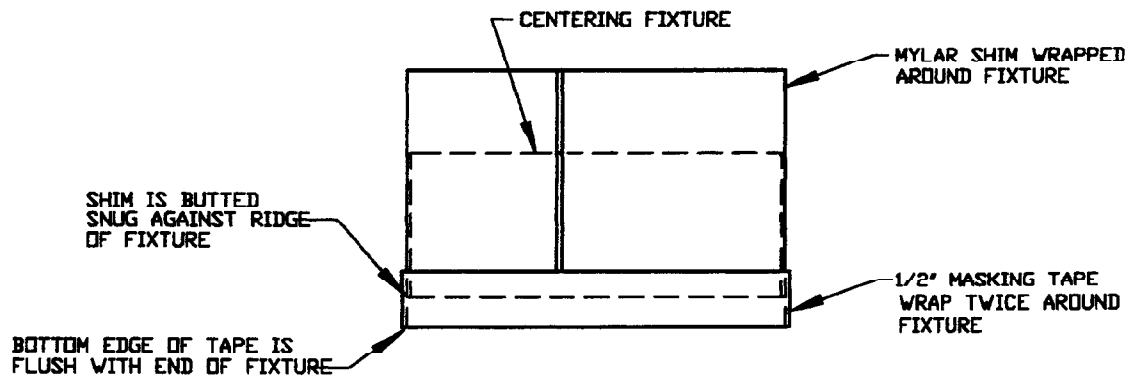

FIGURE 4

CONE FORM CENTERING FIXTURE

SPECIAL CARE MUST BE TAKEN IN PREPARING THE ASSEMBLY. WRAP THE MYLAR SHIM AROUND THE FIXTURE, FITTING IT SNUG AGAINST THE RIDGE ON THE FIXTURE. SECURE THE SHIM IN POSITION BY USING 1/2 INCH WIDE MASKING TAPE, WRAPPING THE TAPE AROUND THE FIXTURE SLEEVE TWICE. TAPE MUST BE FLUSH WITH THE END OF FIXTURE SLEEVE.

ALTEC LANSING CAN SUPPLY BOTH THE COIL FORM CENTERING FIXTURE AND THE SPECIAL MYLAR SHIM.