

## MB1082

### Mounting Bracket Kit

- For Xi-1082 speaker system
- Wall or ceiling mounting possible

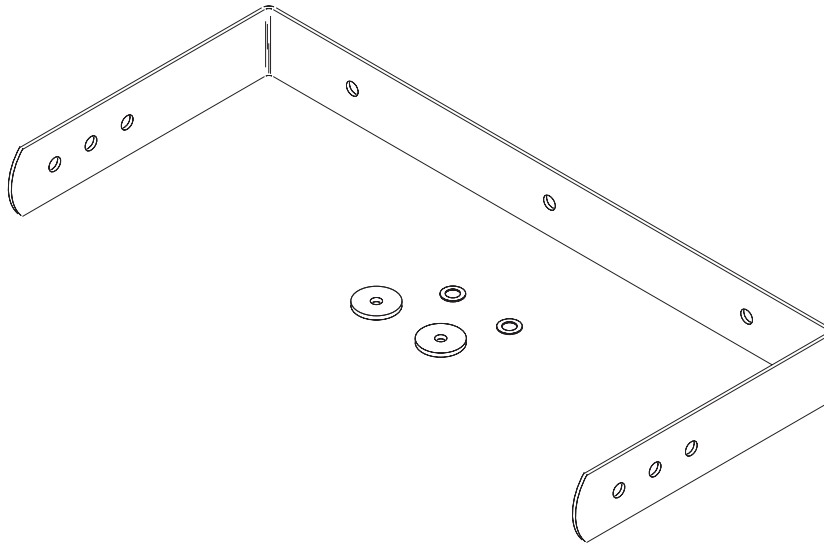

#### Wall or Ceiling Mounting Instructions

Refer to Figure 1 and Table 1 for the following steps:

1. Attach the U-bracket (A) to the wall or ceiling using fasteners that are suitable for the wall or ceiling material (not supplied).
2. Remove the paper backing from the friction pads (C) and attach these to the U-bracket as shown.
3. Remove the two 3/8-16 bolts from each end of the enclosure.
4. Ensuring that the washer (B) is mounted between the U-bracket and the 3/8-16 screw(s) previously removed from the enclosure, mount the Xi-1082 to the U-bracket by selecting two of the six available mounting holes on the bracket.
5. Rotate the speaker so that the input terminal is accessible and attach the wires. Position the speaker for the desired angle and tighten the screws sufficiently so that the speaker does not inadvertently rotate.

#### CAUTION:

**Due to the weight of the Xi-1082 speaker system, it is imperative that the Xi-1082**

**bracket be properly secured to the wall or ceiling. The choice of fastener (not provided with bracket kit) will be determined by the material and construction of the mounting surface.**

#### Uniform Limited Warranty

Electro-Voice products are guaranteed against malfunction due to defects in materials or workmanship for a specified period, as noted in the individual product-line statement(s) below, or in the individual product data sheet or owner's manual, beginning with the date of original purchase. If such malfunction occurs during the specified period, the product will be repaired or replaced (at our option) without charge. The product will be returned to the customer prepaid. **Exclusions and Limitations:** The Limited Warranty does not apply to: (a) exterior finish or appearance; (b) certain specific items described in the individual product-line statement(s) below, or in the individual product data sheet or owner's manual; (c) malfunction resulting from use or operation of the product other than as specified in the product data sheet or owner's manual; (d) malfunction resulting from misuse or abuse of the product; or (e) malfunction occurring

at any time after repairs have been made to the product by anyone other than Electro-Voice or any of its authorized service representatives. **Obtaining Warranty Service:** To obtain warranty service, a customer must deliver the product, prepaid, to Electro-Voice or any of its authorized service representatives together with proof of purchase of the product in the form of a bill of sale or receipted invoice. A list of authorized service representatives is available from Electro-Voice at 600 Cecil Street, Buchanan, MI 49107 (616/695-6831 or 800/234-6831). **Incidental and Consequential Damages Excluded:** Product repair or replacement and return to the customer are the only remedies provided to the customer. Electro-Voice shall not be liable for any incidental or consequential damages including, without limitation, injury to persons or property or loss of use. Some states do not allow the exclusion or limitation of incidental or consequential damages so the above limitation or exclusion may not apply to you. **Other Rights:** This warranty gives you specific legal rights, and you may also have other rights which vary from state to state.

**Electro-Voice Accessories** are guaranteed against malfunction due to defects in mate-

# MB 1082 Mounting Bracket Kit

MB 1082 Mounting Bracket Kit

materials or workmanship for a period of one (1) year from the date of original purchase. Additional details are included in the Uniform Limited Warranty statement.

Service and repair address for this product: Electro-Voice, Inc., 600 Cecil Street, Buchanan, Michigan 49107 (616/695-6831 or 800/234-6831).

Specifications subject to change without notice.

TABLE 1 — MB1082 Parts List

Item	Quantity	Description	Part Number
A	1	U-bracket	74120
B	2	Washers	4053
C	2	Friction pads	38020

Figure 1 — Wall or Ceiling Mounting of Xi-1082 Speaker System with MB1082 Mounting Bracket

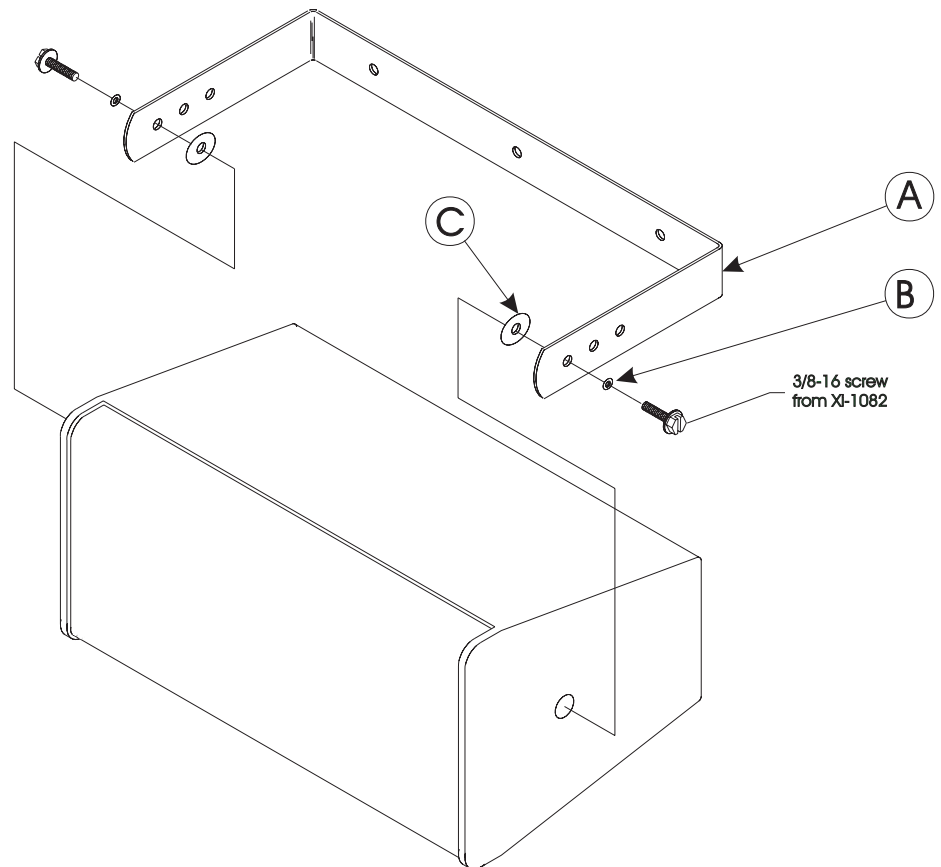

## specifications

### Wall/Ceiling Mounting Holes:

Three in-line, 10-mm (0.40-in.) diameter clearance holes, centers spaced 173-mm (6.8-in.) apart.

### Enclosure Mounting Holes:

Six 10-mm (0.40-in.) diameter clearance holes on the ends of the bracket

### Material:

Hot-rolled steel

### Finish:

Black powder coat

### Parts Supplied (see Table 1):

U-bracket  
Friction pads (two)  
washers (two)

### Net Weight:

1.02 kg (2.25 lb)

### Shipping Weight:

1.47 kg (3.25 lb)

# Electro-Voice®

600 Cecil Street, Buchanan, MI 49107

616/695-6831, 616/695-1304 Fax