

**Electro-Voice®**  
a MARK IV company

# Model HP1240 Constant-Directivity Horn

## SPECIFICATIONS

The following specifications are in accordance with or exceed the AES Recommended Practice for Specification of Loudspeaker Components Used in Professional and Audio Sound Reinforcement (AES2-1984; ANSI S4.26-1984).

### Horizontal Beamwidth:

120° (+20°, -40°)  
(-6 dB, 500 Hz to 20 kHz)

### Vertical Beamwidth:

40° (+20°, -10°)  
(-6 dB, 1.5 kHz to 20 kHz)

### Directivity Factor $R_0$ (Q):

8.40 (average 1.25 kHz to 20 kHz)

### Directivity Index $D_i$ :

9.24 dB (+1.2, -.9 dB)  
10 log  $R_0$ , (average 1.25 kHz to 20 kHz)

### Usable Lower Frequency Limit:

400 Hz

## Construction:

Polyester resin and glass-fiber laminate integrally molded to a die-cast zinc throat section. This hybrid construction assures a rigid driver mount, accurate, loss-free throat-wave transmission and low total weight compared to horns of similar size.

## Mechanical Connection of Driver:

Bolt on; standard 2"-diameter throat, 5"-diameter mounting flange and four clearance holes for 1/4" bolts on a 4"-diameter bolt circle.

## Recommended Drivers:

DH1  
DH2

## Dimensions:

53.3 cm (21.0 in.)  
33.0 cm (13.0 in.)  
26.4 cm (10.4 in.)

## Weight:

3.2 kg (7.0 lb)

## Shipping Weight:

4.1 kg (9.0 lb)

## DESCRIPTION

The Electro-Voice model HP1240 is a wide-range, flat-front, high-frequency, constant-directivity horn. It offers economy of space, where its geometry is "just big enough for the job." The horizontal angle is controlled over a frequency range of 500 Hz to 20 kHz and the vertical angle is controlled from 1.5 kHz to 20 kHz, both with unusual precision and adherence to the intended angle. Furthermore, excellent loading is maintained to a low frequency of 400 Hz. The HP horn series<sup>1</sup> represents the latest development in "CD" horn design, employing the same principles which EV engineers developed and used to design the world's first true constant-directivity horns in 1974. The flat-front design makes the HP1240 suitable for all modern boxed and clustered systems. A unique, lightweight, integral fiberglass-and-zinc construction gives acoustical and mechanical advantages (see Construction section). Lastly, a special vaned waveguide throat detail gives the HP1240 unusually good high-frequency control, vertically, when compared to similar 2-inch-throat horn designs.

1. Patent pending

$R_0$  and  $D_i$  vs Frequency  
(one-third-octave bandwidths)

Freq. (Hz)	$R_0$	$D_i$ (dB)	Freq. (Hz)	$R_0$	$D_i$ (dB)
500	5.32	7.26	3,150	6.54	8.16
630	7.14	8.54	4,000	7.72	8.87
800	9.87	9.94	5,000	6.82	8.33
1,000	10.77	10.32	6,300	6.82	8.34
1,250	11.12	10.46	8,000	8.17	9.12
1,600	9.38	9.72	10,000	8.70	9.39
2,000	8.81	9.45	12,500	8.55	9.32
2,500	8.33	9.21	16,000	9.86	9.94

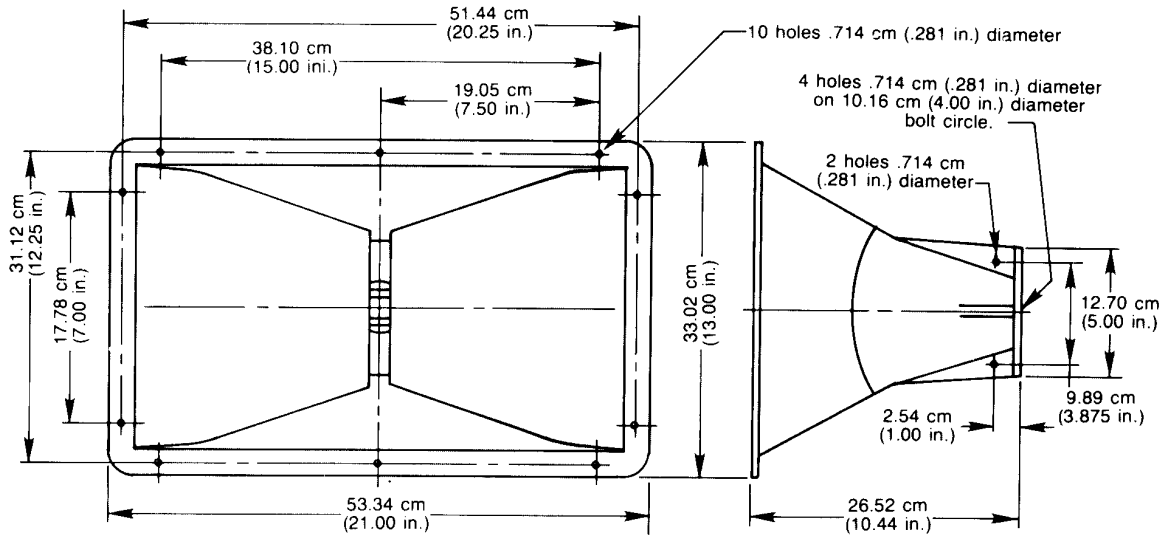

FIGURE 1 — Dimensions

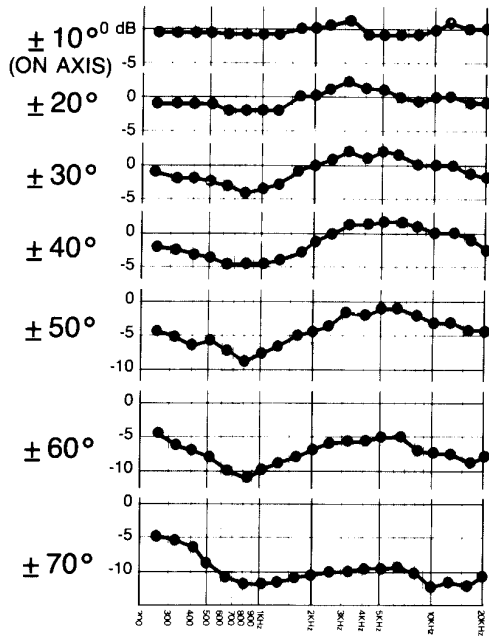

FIGURE 2  
Horizontal Off-Axis Response

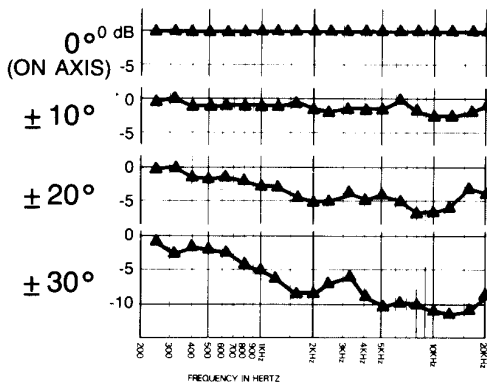

FIGURE 3  
Vertical Off-Axis Response

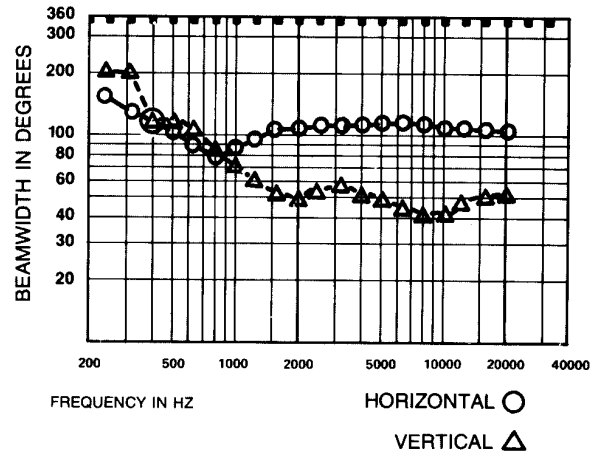

FIGURE 4  
6-dB-Down Beamwidth versus Frequency

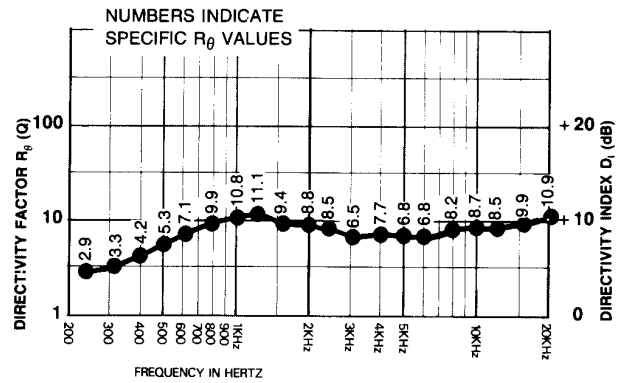
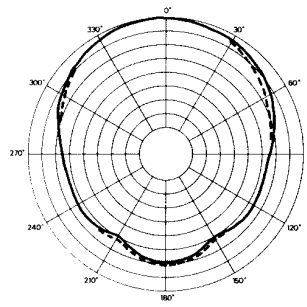
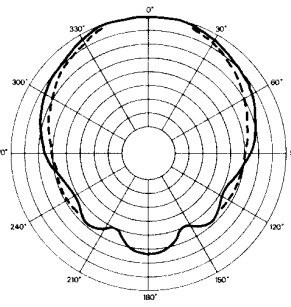

FIGURE 5  
Directivity versus Frequency



**500Hz**



**630Hz**

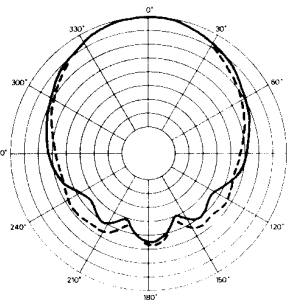

**800Hz**

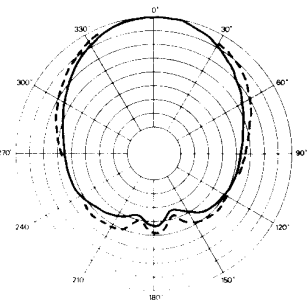

**1kHz**

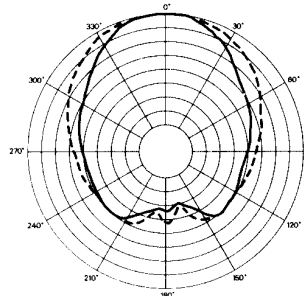

**1.25kHz**

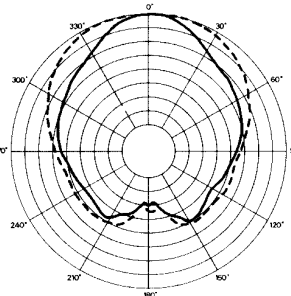

**1.6kHz**

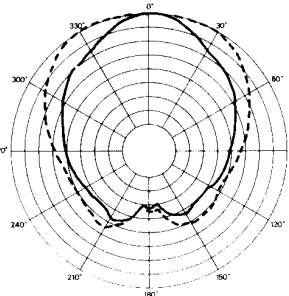

**2kHz**

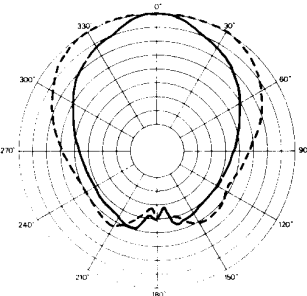

**2.5kHz**

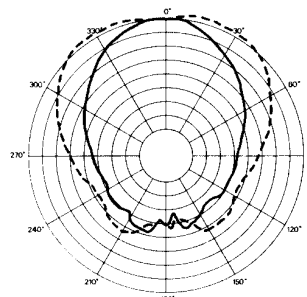

**3.15kHz**

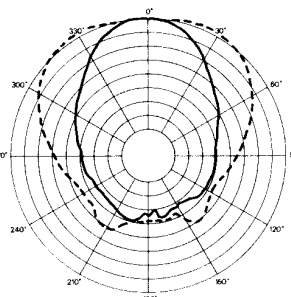

**4kHz**

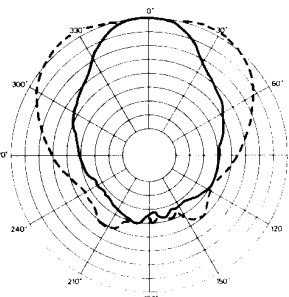

**5kHz**

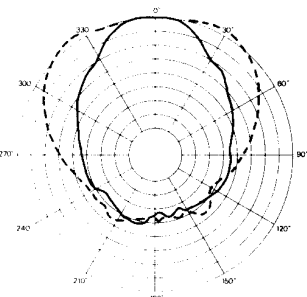

**6.3kHz**

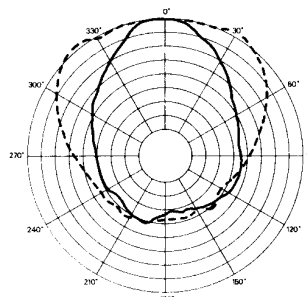

**8kHz**

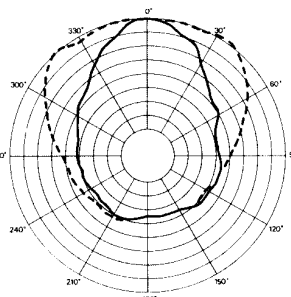

**10kHz**

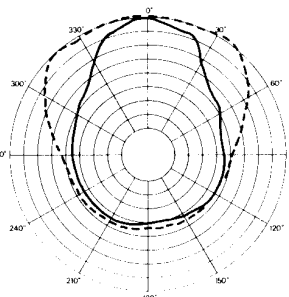

**12.5kHz**

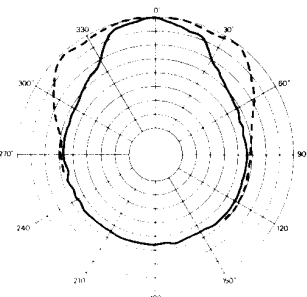

**16kHz**

Scale is 5dB per division

HORIZONTAL — — — —

VERTICAL —————

**FIGURE 6 — Polars**

## BEAMWIDTH

A plot of the HP1240's 6-dB-down total included beamwidth angle is shown in Figure 4 for each one-third-octave center frequency. The horizontal beamwidth is maintained at 120° (+20°, -40°) over the range 500 Hz to 20 kHz. Vertical beamwidth control occurs only above 1.5 kHz because of the relatively short vertical dimension of the horn's mouth.

## FREQUENCY RESPONSE ON AND OFF AXIS

The one-third-octave frequency response of the HP1240 at various on- and off-axis angles, was derived from the accompanying polars and is displayed in Figure 2 and Figure 3. All curves are referenced to the on-axis level. These responses illustrate the curves one would get with a real-time spectrum analyzer at the different angles if the horn/driver were equalized flat on axis, in an anechoic environment.

## POLAR RESPONSE

The directional characteristics of the HP1240 with driver attached were measured by running a set of horizontal/vertical polar responses, in EV's large anechoic chamber, at each one-third-octave center frequency. The test signal was one-third-octave pseudo-random pink noise (1.0-Hz repetition rate)

affle. The polar plots shown in Figure 6 display the results of these tests. The center frequency and beamwidth angle are noted on each plot. The horizontal beamwidth is shown as a dashed line and the vertical beamwidth is shown solid.

## ARCHITECTS' AND ENGINEERS' SPECIFICATIONS

The horn shall be of the constant-directivity type. It shall produce a horizontal beamwidth (6 dB-down angle) of 120 degrees, deviating no more than 40 degrees from this angle over the frequency range 500 to 20,000 Hz. It shall produce a vertical beamwidth of 40 degrees, deviating no more than 20 degrees from this angle over the frequency range 1,500 to 20,000 Hz. In addition, it shall provide useful acoustic loading at all frequencies above 400 Hz.

The horn shall be of hybrid fiberglass-and-zinc construction. The driver-mounting flange and initial throat section shall be constructed of die-cast zinc and shall be integrally laminated into the fiberglass portion of the horn.

The horn shall possess a throat of 4.92-cm (1.94-in.) diameter and its flange shall be provided with four ¼-20-clearance bolt holes on a 10.2-cm (4.0-in.) circle for the mounting of the compression driver. The horn shall be

tion occurs, unit will be repaired or replaced (at our option) without charge for materials or labor if delivered prepaid to the proper Electro-Voice service facility. Unit will be returned prepaid. Warranty does not extend to finish, appearance items, burned coils, or malfunction due to abuse or operation under other than specified conditions, including cone and/or coil damage resulting from improperly designed enclosures, nor does it extend to incidental or consequential damages. Some states do not allow the exclusion or limitation of incidental or consequential damages, so the above exclusion may not apply to you. Repair by other than Electro-Voice or its authorized service agencies will void this guarantee. A list of authorized warranty service agencies is available from Electro-Voice, Inc., 600 Cecil Street, Buchanan, MI 49107 (AC/616-695-6831); or Electro-Voice West, 8234 Doe Avenue, Visalia, CA 93291 (AC/209-651-7777). This warranty gives you specific legal rights, and you may also have other rights which vary from state to state.

Service and repair address for this product: Electro-Voice, Inc., 600 Cecil Street, Buchanan, Michigan 49107.

Specifications subject to change without notice.



**ELECTRO-VOICE, INC., 600 Cecil Street, Buchanan, Michigan 49107**

MANUFACTURING PLANTS AT ■ BUCHANAN, MI ■ NEWPORT, TN ■ SEVIERVILLE, TN ■ OKLAHOMA CITY, OK ■ GANANOQUE, ONT.  
©Electro-Voice Inc. 1991 ■ Litho in U.S.A. Part Number 530633—615

a MARK IV company