



Electro-Voice®
a MARK IV company

**Commercial
Microphones**

US650N/D

DYNAMIC CARDIOID MICROPHONE

SPECIFICATIONS

Element:

Dynamic

Frequency Response (see Figure 1):

80 to 18,000 Hz

Polar Pattern (see Figure 2):

Cardioid

Impedance:

150 ohms, balanced

Output Level:

-54 dB

(0 dB = 1 mW/pascal)

Open-Circuit Voltage:

2.2 mV/pascal at 1,000 Hz

Switch:

On/off (lockable)

Pop Filter:

Built-in Acoustifoam™

Case Material:

Diecast zinc

Finish:

Nonreflective black

Accessories Included:

323 stand clamp

Zippered vinyl carrying case

Optional Accessories:

379 windscreen

PLC-25X cable

Dimensions (see Figure 3),

Length:

169 mm (6.67 in.)

Maximum Diameter:

50.0 mm (1.97 in.)

Net Weight:

276 g (9.7 oz)

Shipping Weight:

470 g (16.6 oz)



DESCRIPTION

The US650N/D is a single-D dynamic cardioid microphone developed for high-quality sound reinforcement and professional performer applications. The US650N/D uses the revolutionary neodymium alloy magnet. This magnet, a rare-earth supermagnet, has four times the power of conventional magnets for increased output level.

The US650N/D has a smooth frequency response and an extended high-frequency response with an open, transparent sound quality due to a large diaphragm that contains 50 percent more surface area than conventional designs and is reinforced to prevent breakup. The US650N/D also provides bass boost (proximity effect) which emphasizes low frequencies when used "close up."

The US650N/D also features a revolutionary vibration-isolation suspension system employing a low-Q elastomeric polymer with extremely high energy absorbing properties. The result is a substantial reduction in handling and cable transmission noise.

The US650N/D features a rugged diecast zinc case, a dent-resistant grille screen that, if dropped, bounces back to retain its shape, and an "on/off" switch that locks in the "on" position if desired. The dynamic element will provide years of reliable operation, even in humidity and temperature extremes. Its exceptional sensitivity, combined with its inherent low noise, ensures a superior signal-to-noise ratio. A pop filter, with specially molded retainers, offers maximum rejection of both wind noise and "P-pop" breath sounds. A uniform cardioid polar pattern ensures superior gain-before-feedback in sound reinforcement applications and prevents "off axis" coloration.

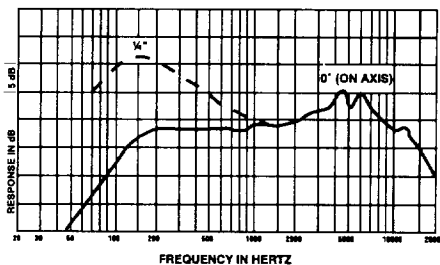

FIGURE 1
Frequency Response

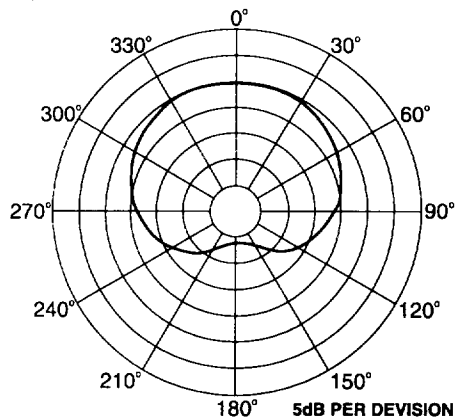

FIGURE 2
Polar Response at 1,000 Hz

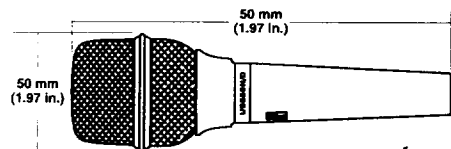

FIGURE 3
Dimensions

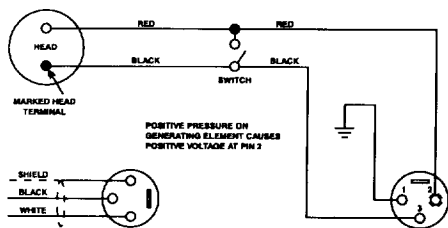

FIGURE 4
Wiring Diagram

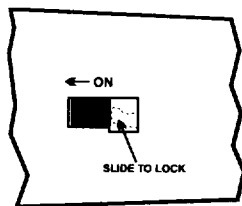

FIGURE 5
Locking Feature

USING THE VARIABLE FREQUENCY RESPONSE (PROXIMITY EFFECT)

The US650N/D's low-frequency response extends by positioning the microphone closer to the sound source (see Figure 1). This proximity effect occurs when the microphone is within 12 inches of the sound source. The effect increases as the working distance decreases. The dashed line in Figure 1 indicates the results of this effect when the microphone is positioned at 1/4-inch from the source.

Imaginative application of the US650N/D's proximity effect creates useful special effects:

1. By working closer to the microphone, the human voice will sound more robust.
2. Working close to the US650N/D reduces the occurrence of PA system feedback better than using the cardioid directional characteristics alone. When close-talked, the substantial bass boost provides an increase in overall microphone output level. The mixer gain may be proportionately reduced, resulting in a reduction of the system's sensitivity to feedback caused by sound entering the microphone from the distant loudspeakers.
3. For musical instrument pickup, use the variable bass response to achieve a clean bass pickup at a distance of 12 inches or more. By moving the US650N/D a few inches from the instrument, the bass will increase.

LOCKABLE ON/OFF SWITCH

Figure 5 shows the US650N/D's "on/off" switch assembly. To lock the switch in the "on" position, slide the metal locking tab into the position shown. A small screwdriver is ideal for this purpose.

WARRANTY (LIMITED) —

Electro-Voice Commercial Microphones are guaranteed for two years from date of original purchase against malfunction due to defects in workmanship and materials. If such malfunction occurs, unit will be repaired or replaced (at our option) without charge for materials or labor if delivered prepaid to Electro-Voice. Unit will be returned prepaid. Warranty does not extend to finish, appearance items, cables, cable connectors, switches, or malfunction due to abuse or operation under other than specified conditions, nor does it extend to incidental or consequential damages. Some states do not allow the exclusion or limitation of incidental or consequential damages, so the above exclusion may not apply to you. Repair by other than Electro-Voice will void this guarantee. This warranty gives you specific legal rights, and you may also have other rights which vary from state to state.

For warranty repair, service information or a listing of the repair facilities nearest you, contact the service repair department at: 405/324-5311 or 800/444-9516.

For technical assistance, call: 800/234-6831.

Specifications subject to change without notice.