



**Electro-Voice**  
a MARK IV company

**Commercial  
Microphones**

# US621L/US622L

## DYNAMIC MICROPHONE

### SPECIFICATIONS

**Element, US621L/US622L:**

Dynamic

**Frequency Response,**

**US621L (see Figure 1):**

100-9,000 Hz

**US622L (see Figure 2):**

125-5,000 Hz

**Polar Pattern,**

**US621L (see Figure 3):**

Omnidirectional

**US622L (see Figure 4):**

Cardioid, noise-cancelling

**Impedance, US621L/US622L:**

150 ohms

**Output Level, US621L/US622L:**

-57 dB (0 dB = 1 mW/10 dynes/cm<sup>2</sup>)

**Case Material, US621L/US622L:**

Pressure-cast zinc and Cynolac

**Finish, US621L/US622L:**

Blue/black

**Dimensions, US621L/US622L,**

**Height:** 246.1 mm (9.69 in.)

**Width:** 114.3 mm (4.5 in.)

**Depth:** 122.2 mm (4.81 in.)

**Net Weight, US621L/US622L:**

822 g (1 lb, 13 oz)

**Switch, US621L/US622L:**

Leaf, DPDT, switches external circuit and shorts or opens mike in "off" position

**Cable, US621L/US622L:**

2.13 m (7 ft) long, 5-conductor, 2-shielded, vinyl jacket, black

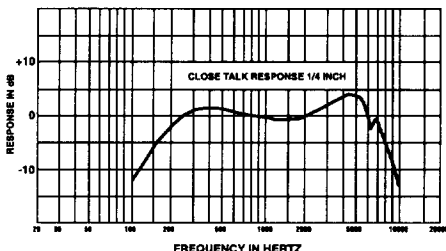
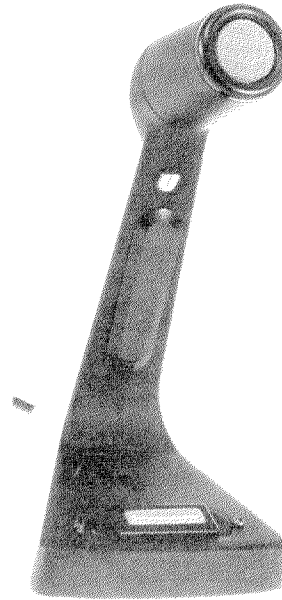

FIGURE 1

US621L Frequency Response

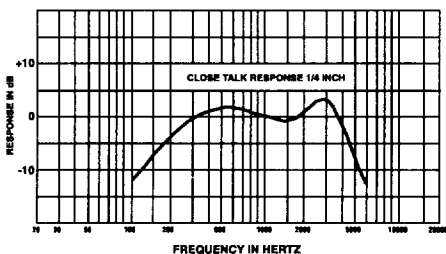

FIGURE 2

US622L Frequency Response

### DESCRIPTION

These microphones were designed for communications and paging applications. Both models are also useful in amateur radio, CB, aeronautical and commercial base station installations.

The US621L is an omnidirectional dynamic microphone with wide-range frequency response, making it an excellent choice for general-purpose and office paging applications.

The US622L is a noise-cancelling dynamic microphone designed for paging, dispatching and call systems in which background noise is high, or for reduction of feedback under difficult acoustical conditions. The US622L allows the user to speak closely into the microphone in a normal voice, while background noise is greatly attenuated. The frequency response was designed to ensure excellent intelligibility.

The rugged, diecast stand is carefully balanced for handheld use as a "grip to talk" microphone, yet will remain firmly positioned for "touch to talk" use. The switch assembly will survive many hundreds of thousands of use cycles—assuring the ultimate in reliability. The switch assembly may be changed from "touch to talk" to "grip to talk." The switch also may be locked in the "on" position for "hands free" operation. There is an adjustment screw that permits the locking feature to be defeated. This control is accessible only when the switch is located in the "touch to talk" position.

### LOCKING FEATURE

In the "touch to talk" position, the switch is locked in the "on" position by depressing the switch bar and sliding it to the right. If the switch assembly is mounted in the "grip to talk" position, the switch bar should be depressed and slid upwards to lock. To unlock the switch bar, reverse the procedure.

### DEFEATING THE LOCKING FEATURE

With the switch in the "touch to talk" configuration, the locking feature may be defeated by an adjustment screw located through the access hole in the bottom plate (see Figure 5). Rotating the screw fully clockwise defeats the locking feature.

To defeat the switch locking feature in the "grip to talk" configuration, the adjustment must be made prior to moving the switch assembly to the neck location. To restore the locking feature, turn the adjustment screw counterclockwise until locking is now possible.

### CHANGING SWITCH CONNECTIONS

The US621L and US622L are shipped with switch connections as shown in Figure 6. The microphones have shorted outputs in the "off" position. See Figure 6 for complete instructions.

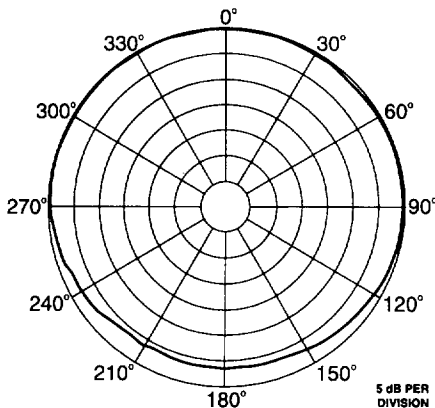

**FIGURE 3**  
**US621L Polar Response**

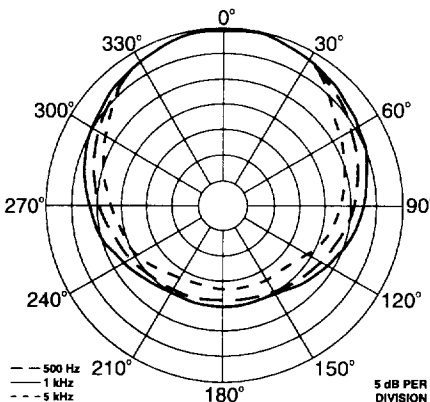

**FIGURE 4**  
**US622L Polar Response**

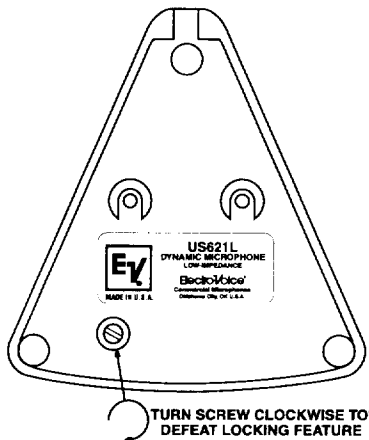

**FIGURE 5**  
**US621L/US622L Bottom View**

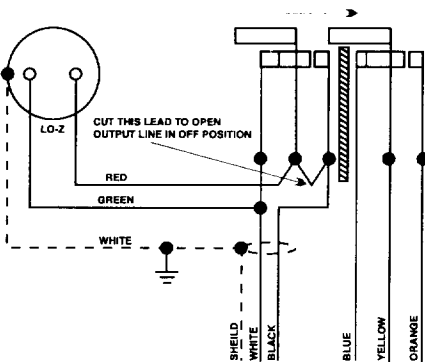

**FIGURE 6**  
**US621L/US622L Wiring Diagram**

The switch assembly is easily accessible for wiring revisions. First, remove the bottom cover plate, then remove the two switch assembly screws to release the assembly for easy access to switch terminals.

### PARALLEL OPERATION

If the US621L and US622L are to be used in applications such as multiple microphone paging installations (where several units are connected in parallel to a single microphone input), changes must be made as shown in Figure 6. Cutting the short wire "opens" the microphone output when the switch is in the "off" position; this will allow multiple microphone applications.

### CHANGING SWITCH CONNECTIONS

The microphones are designed for "touch to talk" or "grip to talk" operation. When received from the factory, the switch is mounted on the base for "touch to talk" use. If desired, the switch may be relocated without wiring changes to the neck of the microphone for "grip to talk" operation.

To relocate the switch, proceed as follows:

1. Remove the black plastic cover from the neck of the microphone by gently lifting one end with a flat blade. This will expose the "grip to talk" switch opening. Save the cover, as it will be needed for the opening on the base of the microphone.
2. Remove two screws and the cover plate from the bottom of the microphone.
3. Slip the strain relief spring from slot.
4. Remove the two screws located in the neck of the microphone.
5. Gently lift switch assembly away from microphone housing.
6. Now turn the entire switch assembly so the top surface of the switch bar faces the front of the microphone with wires protruding from bottom of the switch.
7. Secure switch assembly in the neck with the two screws.
8. Check the action of the switch to ensure that all wires are properly seated and have not become entangled in the switch assembly.
9. Loop the cable around the boss located in the housing base and seat the strain relief spring at the rear of the microphone base. Secure the bottom plate with two screws.
10. Place the black plastic cover into the opening, on the base (from which the red switch bar was previously removed) by inserting the two tabs into the opening and snapping cover into position.

### ARCHITECTS' AND ENGINEERS' SPECIFICATIONS

The model US621L microphone shall be an omnidirectional, dynamic type with uniform frequency response from 100 to 9,000 Hz. The model US622L microphone shall be a noise-cancelling dynamic type with uniform frequency response from 125 to 5,000 Hz. The microphone output impedance shall be specified 150 ohms. The output level shall be -57 dB (0 dB=1mW/10 dynes/cm<sup>2</sup>). The microphone case shall be of Cylcolac and diecast zinc, and shall include a diecast zinc table stand integral with the microphone case. The assembly shall be 246.1 mm (9.69 in.) high, 114.3 mm (4.5 in.) wide and 122.2 mm (4.81 in.) deep.

A DPDT switch shall be provided, one section of which shall normally short-circuit the transducer when switch is in "off" position. (Provisions shall be made for connecting the normally open mode in "off" position and closing the microphone circuit for "on" position for multiple microphone paging installations.) A second section of switch shall be provided with the capability to function either in an electronic switching mode or for operation of external relay. A locking feature shall be provided by means of which switch may be locking in "on" position. A 2.13 m (7 ft) black plastic-jacketed, five-conductor, two-shielded cable shall be furnished. The finish of the integral stand and microphone shall be non-reflecting blue-black. Net weight shall be 822 g (1 lb, 13 oz).

The Electro-Voice Commercial Microphones US621L and US622L are specified.

### WARRANTY (LIMITED) —

Electro-Voice Commercial Microphones are guaranteed for two years from date of original purchase against malfunction due to defects in workmanship and materials. If such malfunction occurs, unit will be repaired or replaced (at our option) without charge for materials or labor if delivered prepaid to Electro-Voice Commercial Microphones. Unit will be returned prepaid. Warranty does not extend to finish, appearance items, cables, cable connectors, switches, or malfunction due to abuse or operation under other than specified conditions, nor does it extend to incidental or consequential damages. Some states do not allow the exclusion or limitation of incidental or consequential damages, so the above exclusion may not apply to you. Repair by other than Electro-Voice Commercial Microphones will void this guarantee. This warranty gives you specific legal rights, and you may also have other rights which vary from state to state.

For warranty repair and service information on Electro-Voice Commercial Microphone products, contact: Electro-Voice Commercial Microphones, 10500 West Reno, Oklahoma City, Oklahoma 73128 (405/324-5311 or 800/444-9516); Attention: Customer Service Department.

For technical assistance, contact the Technical Services Representative at 405/324-5311 or 800/444-9516.

Specifications subject to change without notice.



10500 WEST RENO  
OKLAHOMA CITY, OK 73126

Part Number 532591-9512  
Litho in U.S.A.