

SPECIFICATIONS**Frequency Response:**

3,500-16,000 Hz ± 5 dB
(see Figure 3)

Power Handling,**8 Hours, 6-dB Crest Factor:**

5 watts, long-term (4,000-20,000 Hz pink noise)

Impedance,**Nominal:**

8 ohms

Minimum:

7 ohms (above 3,500 Hz)

Sound Pressure Level at 1 Meter,

1 Watt Input Averaged, Pink Noise
Band-Limited from 3,000 to 15,000 Hz:
105 dB

Horizontal Beamwidth:

95° @ 8 kHz

Vertical Beamwidth:

65° @ 8 kHz

Directivity Factor R_{θ} (Q):

9.9 @ 8 kHz

Usable Low-Frequency Limit:

3,500 Hz

Construction:

Rugged diecast aluminum horn finished in baked black enamel

Voice-Coil Diameter:

2.54 cm (1.0 in.)

Magnet Weight:

0.23 kg (0.5 lb)

Magnet Material:

Strontium ferrite

Flux Density:

1.35 Tesla

Dimensions,**Height:**

13.3 cm (5.3 in.)

Width:

5.1 cm (2.0 in.)

Depth:

6.0 cm (2.4 in.)

Net Weight:

0.85 kg (1.87)

Shipping Weight:

1.01 kg (2.4 lb)

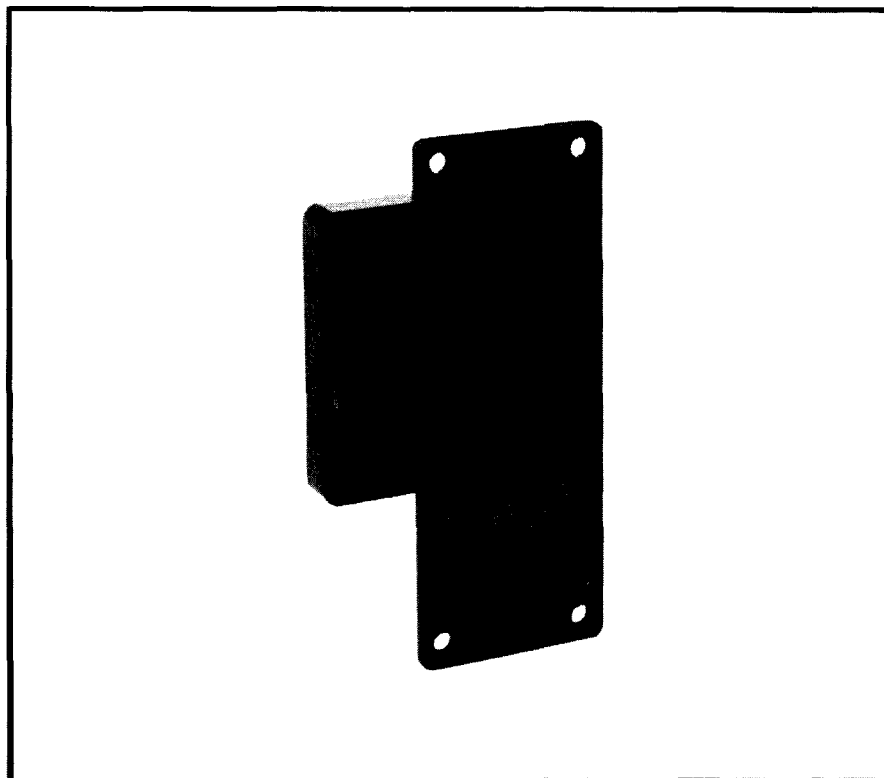
**T35A****Horn Tweeter****DESCRIPTION**

The University Sound T35A is a horn tweeter designed for use above 3,500 Hz in high-efficiency speaker systems.

The tweeter is rated at 5 watts for long-term use and 50 watts for short-term. The integral diffraction horn combines wide dispersion, small size, and easy mounting.

With its smooth, extended high-frequency response, the T35A can be used with other University Sound components to construct two- or three-way loudspeaker systems with a wide variety of sound reinforcement applications.

POLAR RESPONSE

The directional characteristics of the T35A were measured by running a set of horizontal/vertical polar responses, in University's large anechoic chamber, at each one-third-octave center frequency. The test signal was one-third-octave pseudo-random pink noise centered at the indicated frequencies. The measurement microphone was placed 6.1 m (20 ft.) from the horn mouth, while rotation was about the waveguide geometric apexes. These axes of rotation are quite close to the apparent (acoustic) apexes across the frequency range of measurement. Errors attributable to the slight differences between the geometric and acoustic apexes are reduced to an inconsequential level by the relatively long, 20-foot measuring distance. The horn was suspended freely with no baffle. The polar plots shown in Figure 1 display the results of these tests. The center frequency is noted on each plot. The wider plot on each chart is the horizontal polar (—) and the narrower plot is the vertical polar (---).

BEAMWIDTH

A plot of the T35A's 6-dB-down total included beamwidth angle is shown in Figure 2 for each one-third-octave center frequency.

FREQUENCY RESPONSE

Figure 3 shows the axial frequency response of the T35A. It was measured at a distance of 1 meter, using a swept sine wave.

Mounting to the Speaker Baffle

Since the magnet structure of the T35A is too large for front mounting through a hole cut for the horn, rear-mounting to the rear of the speaker baffle is necessary. The baffle opening must be 2.71 cm (1.68 in.) by 10.72 cm (4.22 in.) for best results. In addition, the rear surface of the speaker baffle should be routed out to reduce the thickness from the usual 1.9 cm (0.75 in.) to 0.63 cm (0.25 in.). The routed portion should be concentric with the tweeter baffle opening and measure 5.72 cm (2.25 in.) by 14.0 cm (5.5 in.), allowing plenty of clearance for the horn.

System Wiring

Stranded wire of 22 gauge or larger should be used to connect the T35A within either a two-way system as shown in Figure 4 or a three-way as shown in Figure 5.

CROSSOVER AND LEVEL ADJUSTMENT

A minimum crossover frequency of 3,500 Hz should be used with the T35A to prevent entrance of lower frequencies harmful to the voice coil/diaphragm assembly. The University Sound X36 Crossover is ideal for matching to all University Sound full-range cone speakers and midrange components. In such cases, an AT38 Level Control is recommended to match sensitivity of components.

SETTING THE TWEETER LEVEL CONTROL

To match the output of the T35A to the woofer, counterclockwise (downward) adjustment of the AT38 Level Control will normally be required. Proper adjustment will render a more natural quality of sound.

ARCHITECTS' AND ENGINEERS' SPECIFICATIONS

The horn tweeter shall be of diecast aluminum construction finished in baked black enamel, with a rugged phenolic diaphragm and 1.0-inch diameter voice coil.

The axial frequency response will extend from 3,500 to 16,000 Hz and the horn shall exhibit a low-frequency cutoff of 2,500 Hz. Sound pressure level will be 105 dB (1 W:1 M) with a 3,000 to 15,000 Hz pink noise signal applied, and the horn will produce a horizontal beamwidth of 95° and a vertical beamwidth of 65° at 8.0 kHz. The horizontal coverage shall be constant over the frequency range of 4 kHz to 10 kHz.

The loudspeaker shall be capable of handling a 5-watt, 4,000 Hz to 20,000 Hz pink noise signal with a 6-dB crest factor for a period of eight hours.

The loudspeaker will have a height of 13.3 cm (5.3 in.), a width of 5.1 cm (2.0 in.) and a depth of 6.0 cm (2.4 in.). The loudspeaker shall be the University Sound T35A and shall weigh no more than 0.85 kg (1.87 lb).

WARRANTY (Limited) — University Sound Speakers and Speaker Systems (excluding active electronics) are guaranteed for five years from date of original purchase against malfunction due to defects in workmanship and materials. If such malfunction occurs, unit will be repaired or replaced (at our option) without charge for materials or labor if delivered prepaid to University Sound. Unit will be returned prepaid. Warranty does not extend to finish, appearance items, burned coils, or malfunction due to abuse or operation under other than specified conditions, including cone and/or coil damage resulting from improperly designed enclosures, nor does it extend to incidental or consequential damages. Some states do not allow the exclusion or limitation of incidental or consequential damages, so the above exclusion may not apply to you. Repair by other than University Sound will void this guarantee. This warranty gives you specific legal rights, and you may also have other rights which vary from state to state.

Service and repair address for this product: University Sound, Inc., Phone 818 362-9516, FAX 818 367-5292.

Applications and technical information for University Sound products: University Sound, Inc., Technical Coordinator, Phone 818 362-9516, FAX 818 367-5292.

Specifications subject to change without notice.

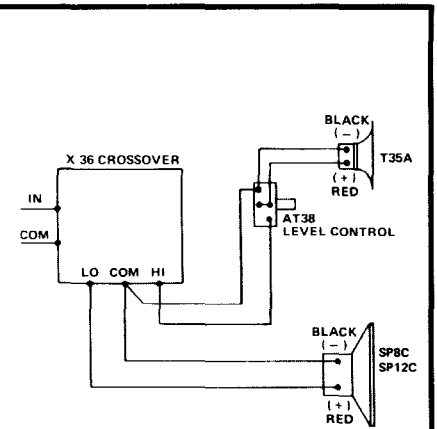

FIGURE 4
Two-Way System Wiring

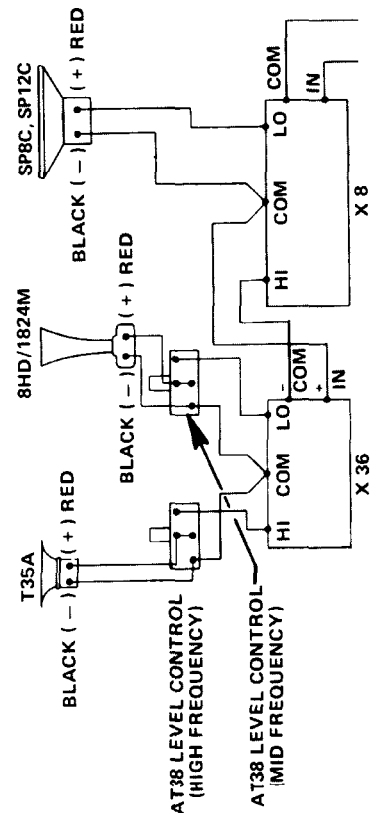
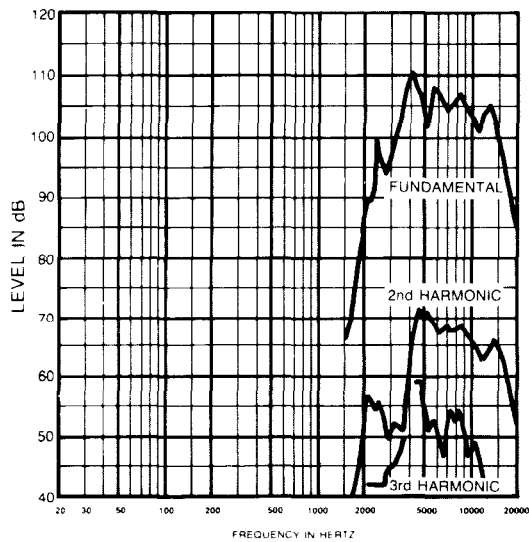
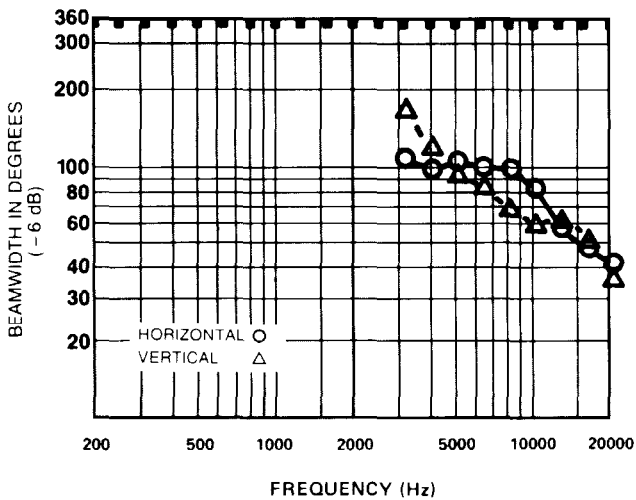
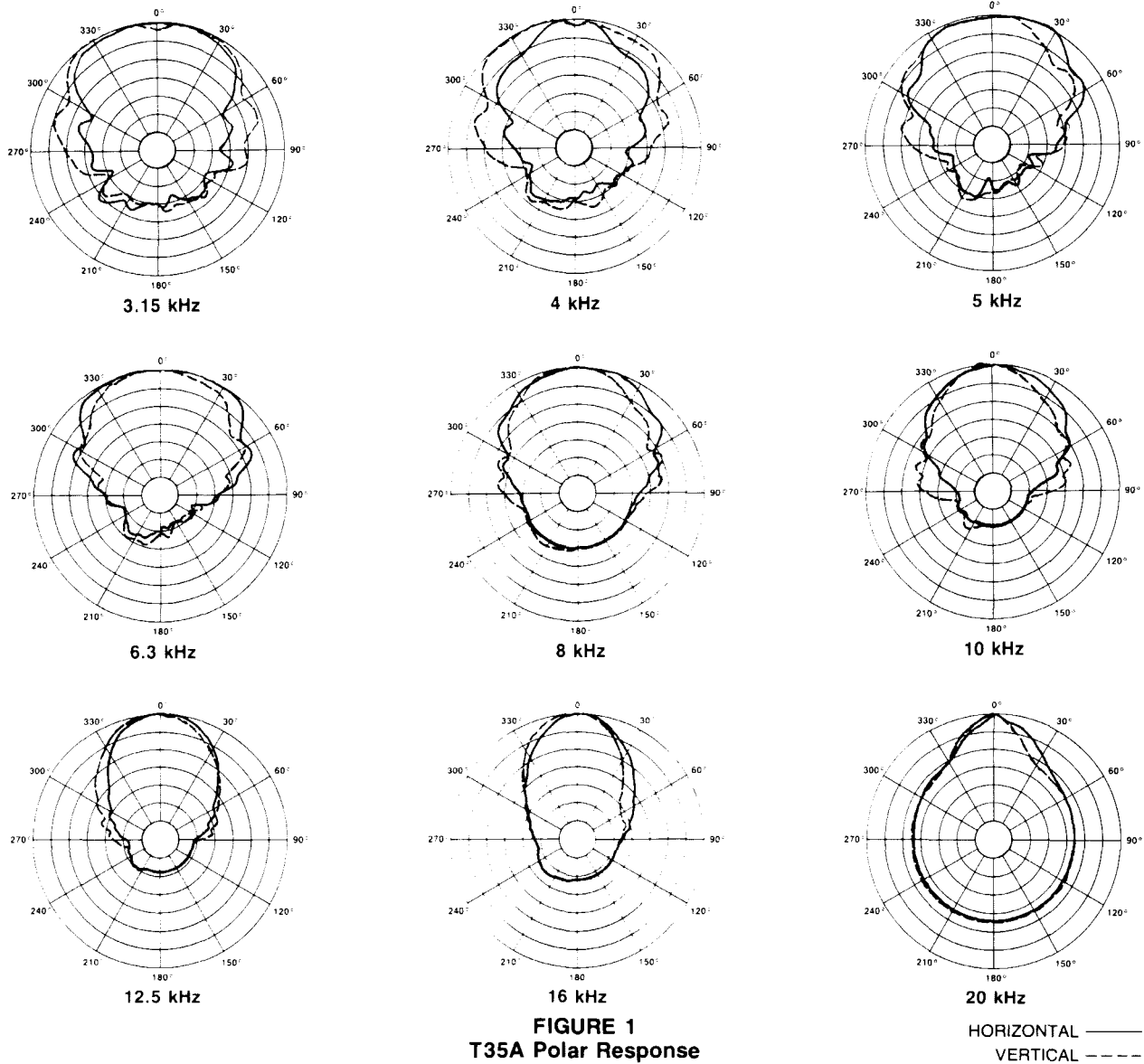

FIGURE 5
Three-Way System Wiring



BASIC GUIDELINES FOR THE USE OF HORNS AND DRIVERS WITHIN A SOUND SYSTEM.

DESIGNING FOR INTELLIGIBILITY AND ADEQUATE SPL

The Basic Idea

Many sound systems would have better performance if the following basic principles are kept in mind. Speakers with the appropriate coverage patterns should be chosen, aimed and powered to achieve a uniform direct field in the highly absorptive audience, with no sound aimed at the reflective wall and ceiling surfaces. Where multiple speakers are required in order to achieve a uniform direct field, their coverage patterns should be only slightly overlapped so that each section of the audience is covered by a single speaker. To the extent this ideal is achieved, reverberation is minimized and intelligibility is maximized.

The following material explains these concepts in more detail and illustrates two design approaches.

What is Reverberation?

Reverberation is the persistence of sound within an enclosure, such as a room, after the original sound has ceased. Reverberation may also be considered as a series of multiple echoes so closely spaced in time that they merge into a single continuous sound. These echoes decrease in level with successive reflections, and eventually are completely absorbed by the room.

Non-Reverberant Environments

An open, outdoor space is considered to be a non-reverberant environment, as virtually all sound escapes the area without reflection.

Variations in Level Due to Distance for Non-Reverberant Environments

In non-reverberant environments, such as outdoors, sound pressure level will be reduced by half (6 dB) every time the distance from the speaker is doubled (this is called the inverse-square law). Figure A shows the dB losses to be expected as distance from the speaker is increased from the one-meter (3.28-foot) measuring distance typically used in SPL specifications.

Reverberant Environments

Where sound is reflected from walls and other surfaces, there is a point beyond which the "reverberant field" dominates and the sound pressure level is higher and more constant than predicted by using the inverse-square law alone.

Variations in Level Due to Distance for Reverberant Environments

The reverberant field will begin to dominate typically at distances of 10 to 30 feet. This distance is greatest for the least reverberant rooms and speakers with narrow beamwidth angles. The frequency and beamwidth specifications provided by the data sheet are still required to obtain satisfactory distribution of the direct sound (or direct field) from the loudspeaker(s), which still follows the inverse-square law. It is the direct signal that contributes to speech intelligibility. This is why the sound system designer should seek a uniform direct field, with as little reverberant field as possible. For example, consider a single speaker with a wide beamwidth angle used to cover a long, narrow, reverberant room. The direct field will be so far below the reverberant field at the back of the room that speech will probably be unintelligible.

Calculating Variations in Level Due to Changes in Electrical Power

Each time the power delivered to the speaker is reduced by one-half, a level drop of 3 dB occurs. The nomograph of Figure B shows the change in dB to be expected as the power varies from the one-watt input typically used in SPL specifications.

Power Handling

The power rating of a speaker must be known to determine whether a design is capable of meeting the sound pressure level requirements of the system. The power rating combined with the sensitivity will enable a system designer to calculate the maximum sound pressure level attainable at a given distance.

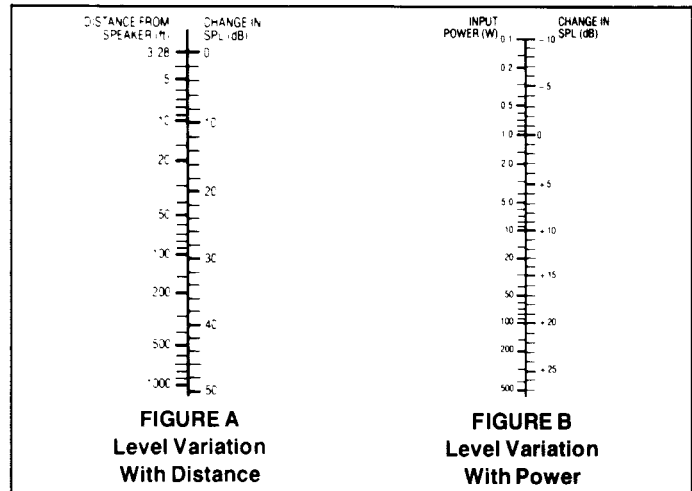

Powering to Achieve Both Average and Peak SPL

The average power that must be delivered to the speaker(s) to achieve the desired average SPL can be determined from the previously presented material on speaker sensitivity, level variation with distance and level variation with power. Enough additional power must be available to reproduce without distortion the short-term peaks that exist in voice and music program. This difference between the peak and average capability of a sound system, when expressed in dB, is often called "peak-to-average ratio," "crest factor" or "headroom." The peaks can be large, as noted earlier: at least 10 times the average (10 dB).

The better sound systems are designed for peaks that are 10 dB above the average, although 6 dB of headroom is sufficient for most general-purpose voice paging systems. The 10-dB peaks require amplifier power ten times that required for the average sound levels. The 6-dB peaks require four times the power.

Utilizing Speaker Beamwidth Information for Maximum Intelligibility

Knowing the beamwidth angle of a loudspeaker can aid in providing a uniform direct field in the listening area. After selecting a desired speaker location, the beamwidth angle needed to adequately cover the listeners without spilling over to the walls or ceilings must be determined. Once these angles are known, the correct speaker can be found by using catalog specifications.

Using Easy-VAMP™ and Floor-Plan Isobars

In some circumstances, it is desirable to use an approach that is more detailed than using the basic horizontal and vertical beamwidth angles. Environments which have excessive reverberation or high ambient noise levels make it especially difficult to achieve the desired SPL and intelligibility.

In recent years, a number of computer-based techniques have been developed to help sound system designers. Some of the more complex systems use personal computers, with relatively sophisticated graphics. Simpler systems, such as Electro-Voice's VAMP™ (Very Accurate Mapping Program) utilize clear overlays and require programmable scientific calculators. However, the hardware/software and training investment required to utilize even the simpler systems are not attractive to some sound systems designers. Because of this, University Sound has developed a special adaptation of VAMP, called Easy-VAMP™, which provides a similar design aid without the complexity and cost of the VAMP programs.

More information on both the Easy-VAMP™ and floor-plan isobars can be found in the University Sound Guide.