

SPECIFICATIONS**Frequency Response:**

110-18,000 Hz ± 5 dB
(see Figure 3)

Power Handling:

100 watts (EIA Standard RS-426A)

Impedance,

Nominal:

8 ohms

Minimum:

8 ohms

Sound Pressure Level at 1 Meter,

**1 Watt Input Averaged, Pink Noise
Band-Limited from 300 to 2,000 Hz:**
98 dB

Horizontal Beamwidth:

110° @2 kHz

Vertical Beamwidth:

20° @ 2 kHz

Directivity Factor R_0 (Q):

9.7 @ 2 kHz

Usable Low-Frequency Limit:

90 Hz

Crossover Frequency:

3,000 Hz (12-dB-per-octave)

Construction:

Utility black finish on plywood sides and top with particle board back. Grille is perforated metal in front of a foam water barrier.

Dimensions,**Height:**

122.0 cm (48.0 in.)

Width:

24.8 cm (9.8 in.)

Depth:

19.0 cm (7.5 in.)

Net Weight,

18.0 kg (40.0 lb)

Shipping Weight:

20.0 kg (45.0 lb)

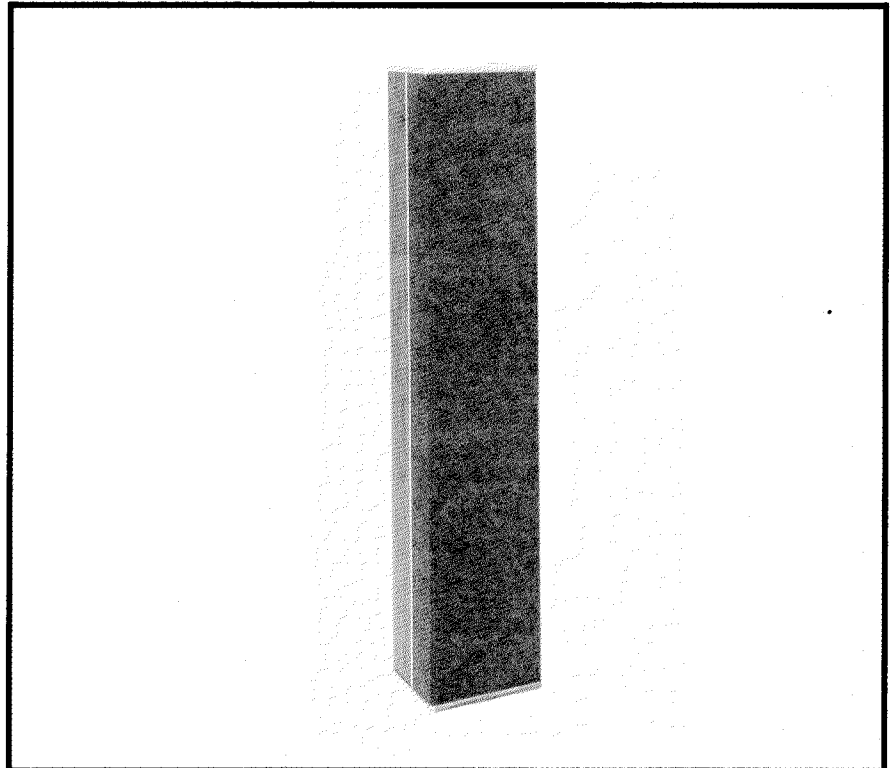
**LR4B****All-Weather
Line Radiator****DESCRIPTION**

The University Sound LR4B Line Radiator is a two-way "column" format loudspeaker designed for both indoor and outdoor applications.

The LR4B has a vertical array of 5-inch x 7-inch elliptical low-frequency speakers working with an ST350B constant-directivity radial horn tweeter, connected to a tweeter protector.

The loudspeakers are mounted on a multi-faceted baffle designed for more uniform coverage of vertical sound and control at midrange frequencies.

The ST350B tweeter confines dispersion to a 60° vertical, by 120° horizontal area, thus extending the coverage zone of the 5-inch x 7-inch speakers.

The LR4B solves or minimizes sound reinforcement problems of feedback, and spotty coverage, that can be associated with some horn/woofer systems in use.

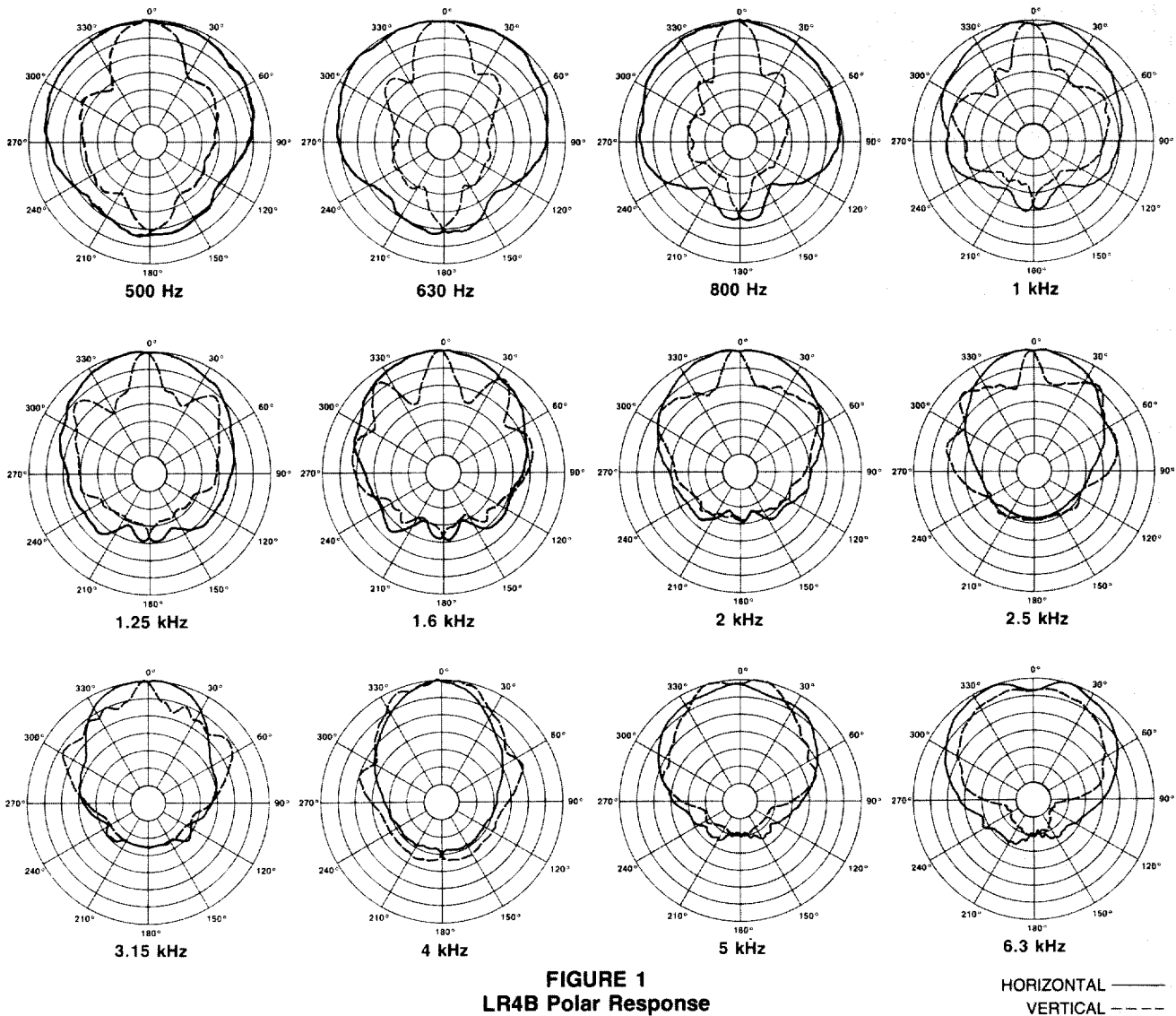

FIGURE 1
LR4B Polar Response

HORIZONTAL ———
VERTICAL - - - -

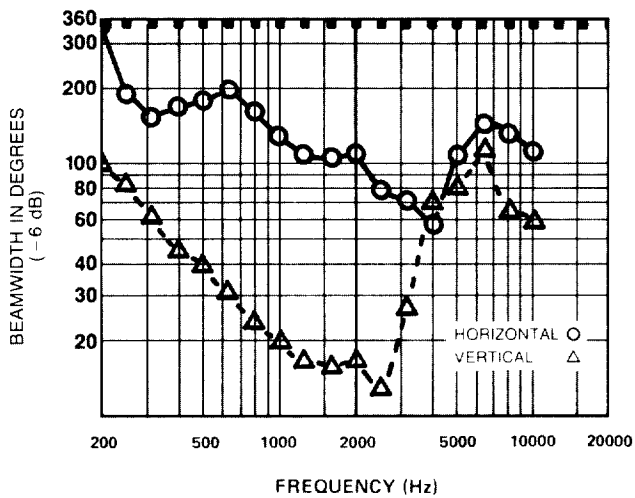

FIGURE 2
LR4B Beamwidth vs. Frequency

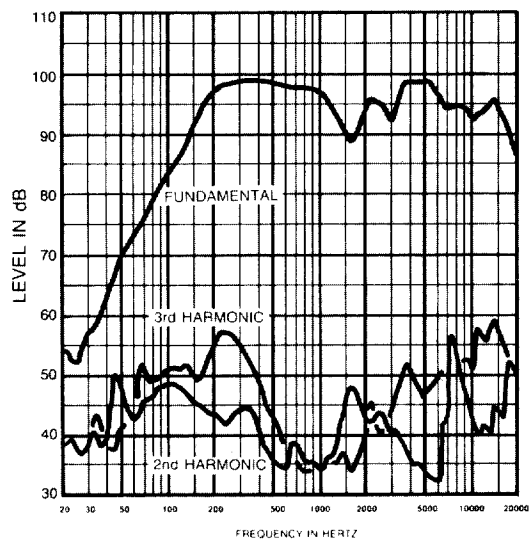

FIGURE 3
LR4B Frequency Response
(1 watt at 1 meter)

POLAR RESPONSE

The directional characteristics of the LR4B were measured by running a set of horizontal/vertical polar responses, in University's large anechoic chamber, at each one-third-octave center frequency. The test signal was one-third-octave pseudo-random pink noise centered at the indicated frequencies. The measurement microphone was placed 6.1 m (20 ft.) from the loudspeaker. The polar plots shown in Figure 1 display the results of these tests. The center frequency is noted on each plot. The wider plot on each chart is the horizontal polar (—) and the narrower plot is the vertical polar (---).

BEAMWIDTH

A plot of the LR4B's 6-dB-down total included beamwidth angle is shown in Figure 2 for each one-third-octave center frequency.

FREQUENCY RESPONSE

Figure 3 shows the axial frequency response of the LR4B. It was measured at a distance of 1 meter, using a swept sine wave.

POWER HANDLING TEST

The LR4B is designed to withstand the power test described in EIA Standard RS-426A. The EIA test spectrum is applied for eight hours. To obtain the spectrum, the output of a white noise generator (white noise is a particular type of random noise with equal energy per bandwidth in Hz) is fed to a shaping filter with 6-dB-per-octave slopes below 40 Hz and above 318 Hz. When measured with usual constant-percentage-bandwidth analyzer (one-third-octave), this shaping filter produces a spectrum whose 3-dB-down points are at 100 Hz and 1,200 Hz with a 3-dB-per-octave slope above 1,200 Hz. This shaped signal is sent to the power amplifier with the continuous

power set at 100 watts into the EIA equivalent impedance (28.3 volts true RMS). Amplifier clipping sets instantaneous peaks at 6 dB above the continuous power, or 400 watts peak (56.6 volts peak). This procedure provides a rigorous test of both thermal and mechanical failure modes.

MOUNTING

The LR4B can be mounted vertically in most locations, providing even coverage throughout, however, horizontal installation is especially effective in long, narrow coverage areas and for distributed systems.

Hardware provided for mounting includes "S" hooks, hinge, and 8-foot sash chain (see Figure 4).

ARCHITECTS' AND ENGINEERS' SPECIFICATIONS

The loudspeaker shall be a multi-faceted straight "line radiator" type using six 5-inch x 7-inch cone speakers and a constant-directivity ST350B tweeter.

The speakers are housed in a weather-sealed wooden enclosure with black utility-paint finish. A foam-backed metal grille shall be provided on the front of the line radiator for protection from weather and physical damage. Overall size shall be 122.0 cm (48.0 in.) high, by 24.8 cm (9.8 in.) wide, by 19.0 cm (7.5 in.) deep.

Frequency response shall be uniform from 110 to 18,000 Hz. Nominal dispersion angles included by 6-dB-down points using one-third-octave bands of noise shall be 110° horizontal and 20° vertical in the 500 to 3,000 Hz range.

Axial sound pressure level at one meter, one watt input under anechoic conditions using

300-2,000 Hz band-limited pink noise, shall be 98 dB.

Net weight shall be 18 kg (40 lb). The University Sound Model LR4B is specified.

WARRANTY (Limited) — University Sound Speakers and Speaker Systems (excluding active electronics) are guaranteed for five years from date of original purchase against malfunction due to defects in workmanship and materials. If such malfunction occurs, unit will be repaired or replaced (at our option) without charge for materials or labor if delivered prepaid to University Sound. Unit will be returned prepaid. Warranty does not extend to finish, appearance items, burned coils, or malfunction due to abuse or operation under other than specified conditions, including cone and/or coil damage resulting from improperly designed enclosures, nor does it extend to incidental or consequential damages. Some states do not allow the exclusion or limitation of incidental or consequential damages, so the above exclusion may not apply to you. Repair by other than University Sound will void this guarantee. This warranty gives you specific legal rights, and you may also have other rights which vary from state to state.

Service and repair information for this product: University Sound, Inc., Phone 818/362-9516, FAX 818/367-5292.

Applications and technical information for University Sound products: University Sound, Inc., Technical Coordinator, Phone 818/362-9516, FAX 818/367-5292.

Specifications subject to change without notice.

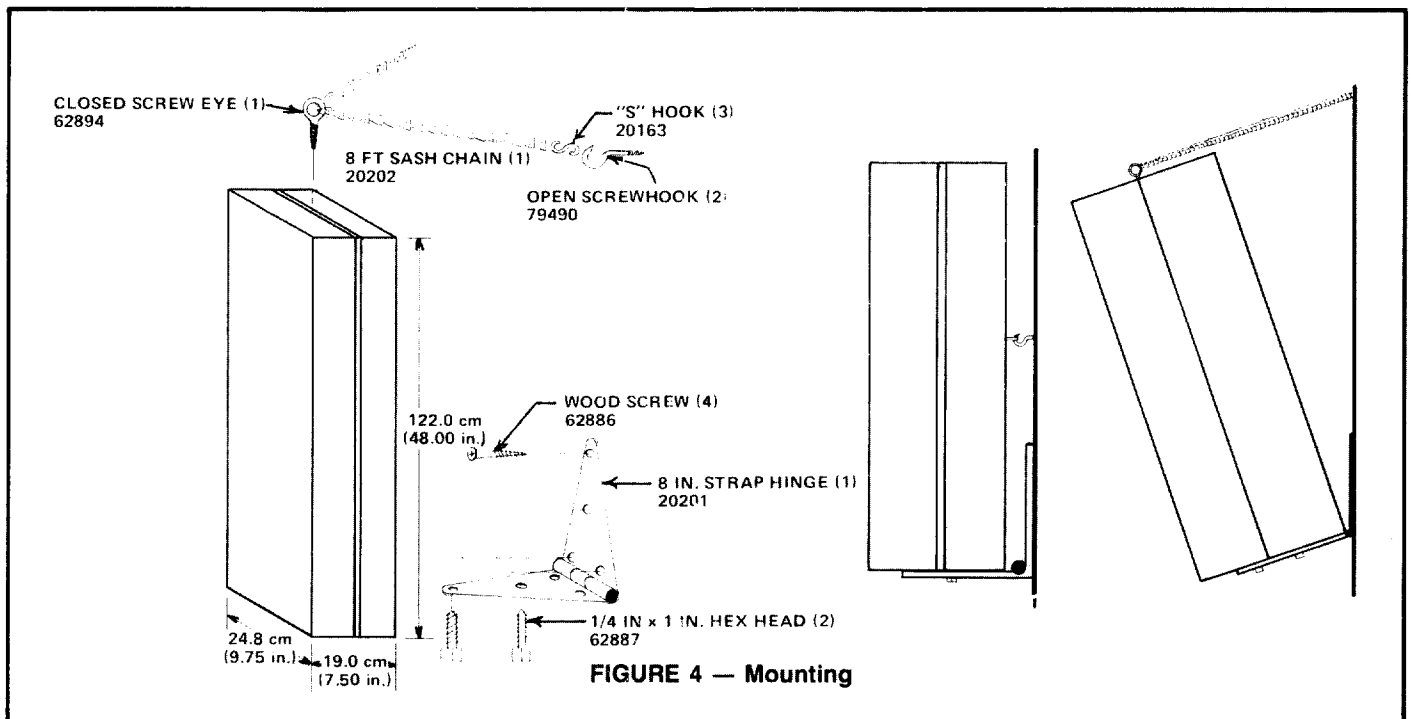

BASIC GUIDELINES FOR THE USE OF HORNS AND DRIVERS WITHIN A SOUND SYSTEM.

DESIGNING FOR INTELLIGIBILITY AND ADEQUATE SPL

The Basic Idea

Many sound systems would have better performance if the following basic principles are kept in mind. Speakers with the appropriate coverage patterns should be chosen, aimed and powered to achieve a uniform direct field in the highly absorptive audience, with no sound aimed at the reflective wall and ceiling surfaces. Where multiple speakers are required in order to achieve a uniform direct field, their coverage patterns should be only slightly overlapped, so that each section of the audience is covered by a single speaker. To the extent this ideal is achieved, reverberation is minimized and intelligibility is maximized.

The following material explains these concepts in more detail and illustrates two design approaches.

What is Reverberation?

Reverberation is the persistence of sound within an enclosure, such as a room, after the original sound has ceased. Reverberation may also be considered as a series of multiple echoes so closely spaced in time that they merge into a single continuous sound. These echoes decrease in level with successive reflections, and eventually are completely absorbed by the room.

Non-Reverberant Environments

An open, outdoor space is considered to be a non-reverberant environment, as virtually all sound escapes the area without reflection.

Variations in Level Due to Distance for Non-Reverberant Environments

In non-reverberant environments, such as outdoors, sound pressure level will be reduced by half (6 dB) every time the distance from the speaker is doubled (this is called the inverse-square law). Figure A shows the dB losses to be expected as distance from the speaker is increased from the one-meter (3.28-foot) measuring distance typically used in SPL specifications.

Reverberant Environments

Where sound is reflected from walls and other surfaces, there is a point beyond which the "reverberant field" dominates and the sound pressure level is higher and more constant than predicted by using the inverse-square law alone.

Variations in Level Due to Distance for Reverberant Environments

The reverberant field will begin to dominate typically at distances of 10 to 30 feet. This distance is greatest for the least reverberant rooms and speakers with narrow beamwidth angles. The frequency and beamwidth specifications provided by the data sheet are still required to obtain satisfactory distribution of the direct sound (or direct field) from the loudspeaker(s), which still follows the inverse-square law. It is the direct signal that contributes to speech intelligibility. This is why the sound system designer should seek a uniform direct field, with as little reverberant field as possible. For example, consider a single speaker with a wide beamwidth angle used to cover a long, narrow, reverberant room. The direct field will be so far below the reverberant field at the back of the room that speech will probably be unintelligible.

Calculating Variations in Level Due to Changes in Electrical Power

Each time the power delivered to the speaker is reduced by one-half, a level drop of 3 dB occurs. The nomograph of Figure B shows the change in dB to be expected as the power varies from the one-watt input typically used in SPL specifications.

Power Handling

The power rating of a speaker must be known to determine whether a design is capable of meeting the sound pressure level requirements of the system. The power rating combined with the sensitivity will enable a system designer to calculate the maximum sound pressure level attainable at a given distance.

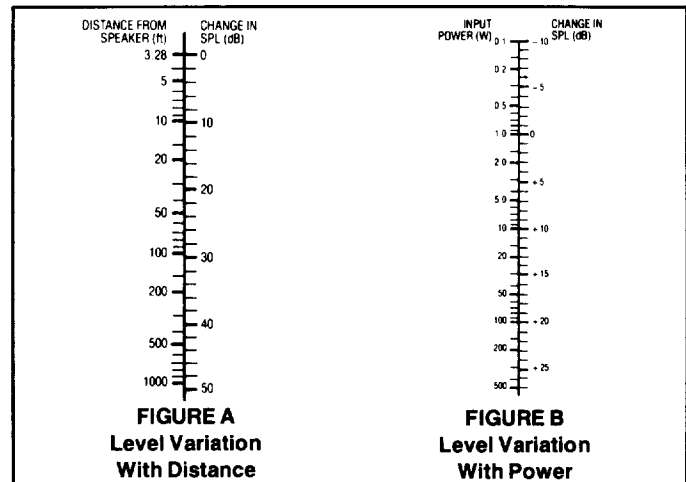

Powering to Achieve Both Average and Peak SPL

The average power that must be delivered to the speaker(s) to achieve the desired average SPL can be determined from the previously presented material on speaker sensitivity, level variation with distance and level variation with power. Enough additional power must be available to reproduce without distortion the short-term peaks that exist in voice and music program. This difference between the peak and average capability of a sound system, when expressed in dB, is often called "peak-to-average ratio," "crest factor" or "headroom." The peaks can be large, as noted earlier: at least 10 times the average (10 dB).

The better sound systems are designed for peaks that are 10 dB above the average, although 6 dB of headroom is sufficient for most general-purpose voice paging systems. The 10-dB peaks require amplifier power ten times that required for the average sound levels. The 6-dB peaks require four times the power.

Utilizing Speaker Beamwidth Information for Maximum Intelligibility

Knowing the beamwidth angle of a loudspeaker can aid in providing a uniform direct field in the listening area. After selecting a desired speaker location, the beamwidth angle needed to adequately cover the listeners without spilling over to the walls or ceilings must be determined. Once these angles are known, the correct speaker can be found by using catalog specifications.

Using Easy-VAMP™ and Floor-Plan Isobars

In some circumstances, it is desirable to use an approach that is more detailed than using the basic horizontal and vertical beamwidth angles. Environments which have excessive reverberation or high ambient noise levels make it especially difficult to achieve the desired SPL and intelligibility.

In recent years, a number of computer-based techniques have been developed to help sound system designers. Some of the more complex systems use personal computers, with relatively sophisticated graphics. Simpler systems, such as Electro-Voice's VAMP™ (Very Accurate Mapping Program), utilize clear overlays and require programmable scientific calculators. However, the hardware/software and training investment required to utilize even the simpler systems are not attractive to some sound systems designers. Because of this, University Sound has developed a special adaptation of VAMP, called Easy-VAMP™, which provides a similar design aid without the complexity and cost of the VAMP programs.

More information on both the Easy-VAMP™ and floor-plan isobars can be found in the University Sound Guide.

