

CSP815-8T

Full-Range Ceiling Loudspeaker System

- CS815 component in an 8-inch diameter enclosure
- Quick and easy to install
- Architecturally pleasing
- High SPL (106.5 dB, 15 W, 1 m)
- Multiple transformer taps
- System ships complete from factory
- 8-watt transformer
- Complies with UL 1480 for general signaling
- Complies with UL 2043 for use in air handling spaces

Description

The University Sound CSP815 series loudspeaker systems are complete full-range ceiling loudspeaker packages. The package consists of a bezel assembly and a speaker assembly. The bezel assembly mounts to the ceiling structure using a series of locking spring connectors. No tools are required to secure the bezel. The speaker assembly consists of the speaker component, transformer and grille premounted in a steel backcan. The bayonet slots on the speaker assembly mate with the pins on the bezel to provide an easy, yet secure, installation. The bezel and perforated grille are finished in semi-gloss white, powder-coated enamel which offers a cosmetically-appealing exterior.

The loudspeaker features a 8-inch curvilinear cone with high-linearity treated cloth surround together with a high-temperature voice-coil assembly. The CSP815 series provides wide and uniform dispersion throughout the critical speech bandwidth.

The CSP815-8T series utilizes a transformer that offers a selection of taps at 1, 2, 4 and 8 watts, delivered to the loudspeaker system using either 70-V or 100-V lines.

The rear enclosure provides an optimum internal volume ensuring extended low-frequency

performance. It is constructed from heavy-gauge, rugged cold-rolled steel, and finished with a rust-inhibiting zinc plating. A rear cover, with provisions for a junction box fitting, provides access to an 8-pin terminal block that allows direct connection to each of the transformer taps.

An optional tile bridge system is available for safe suspension of the CSP815 series in a drop ceiling that uses mineral-wool or other fiber-based ceiling tiles.

The CSP815 series has been designed to work as a complete system in a wide range of different ceiling constructions. They provide wide dispersion, high efficiency, high maximum output, ease of installation, and wide-range reproduction of music or voice.

Mounting the System in a Ceiling

The University Sound CSP series ceiling speaker systems have been designed to accommodate a wide range of ceiling tile and structural ceiling materials. The spring assemblies can accommodate a range of material thicknesses from 0.375-inch up to 1.25-inch thick.

Before beginning the installation, determine the type of material employed in the ceiling. For all "soft" ceiling tiles it is imperative that the optional CTB-8 ceiling tile bridge be uti-

lized. The support rails are 603-mm (23.75-in.) long and will support a loudspeaker system in a 2 ft x 4 ft (or 2 ft x 2 ft) tile. In addition, if angled at 10 to 15 degrees, the tile bridge can be used with 600-mm tiles (see Figure A).

Figure A

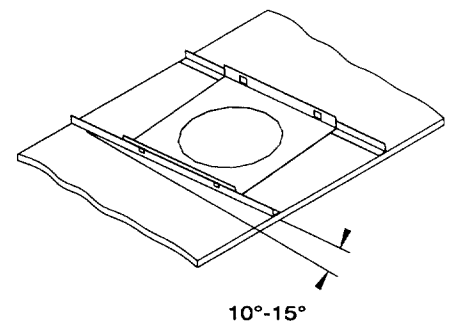

Ceilings constructed from particle board, plywood, gypsum board or plaster do not normally require the use of a tile bridge. However, additional safety is assured when using a tile bridge.

Preparing the Wires

The ceiling system includes an eight-way barrier strip that provides access to each of the transformer taps. Bare-wire connection (up to #10 gauge wire) should be used, and a choice of both screw terminal, or spring-loaded push terminals, have been provided

CSP815 Series Full-Range Ceiling Loudspeaker System

(see Figure B). The recommended strip length is 6.4 mm to 8.0 mm (0.250 in. to 0.312 in.).

Figure B



Using Conduit Fittings

The rear cover has provisions for the use of a junction box, or gland nut style fitting (see Figure C). This allows either solid or flexible conduit to be connected directly to the system. If local codes require the use of conduit, ensure that it is well supported. Too much unsupported weight may prevent the ceiling system from closing flush against the ceiling surface.

Selecting a Transformer Tap

The transformer tap of choice can be obtained by making connection between the ground terminal (#1) and any of the wattage taps indicated on the input label (#5, #6, #7 or #8). Either 70-V or 100-V lines can be used—refer to the input panel label to determine the appropriate wattage for the line voltage used (see Figure B).

Cutting Mounting Holes

- The hole for the 4-inch systems should be 171 mm (6.75 in.) in diameter. (See Figure D)
- The hole for the 6.5-inch systems should be 203 mm (8.00 in.) in diameter.
- The hole for the 8-inch systems should be 241 mm (9.50 in.) in diameter.

Check for electrical conduit/wiring and other hazards before cutting the hole. In addition, allow sufficient clearance for both the depth of the loudspeaker/enclosure and any electrical fittings used.

Figure C

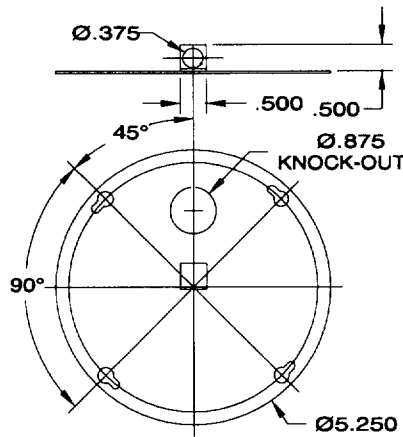

Installation

T-Bar Support

The T-bar system is comprised of two support bars and a support bridge. The bars are inserted through tabs formed in the two sides of the bridge and can be adjusted to allow the cut out to be positioned at any point on the width of, for example, a 4 ft by 2 ft ceiling tile. Additionally, the tile bridge system can be moved along the drop ceiling support rails and positioned at any point along the length of a ceiling tile. The ceiling bridge should be positioned directly above the hole cut in the ceiling tile with the bridge resting directly against the rear of the tile.

Bezel/Spring Assembly

The bezel/spring assembly is installed from "room side" by pushing the inner tubular section up through the hole cut in the ceiling tile. If a tile bridge is used, the bezel's inner tube will also pass through the hole in the tile bridge. The clamp springs ([3] for the 4-inch and 6.5-inch systems and [4] for the

8-inch system) should be released, one at a time, by reaching through the hole. Ensure

Figure D

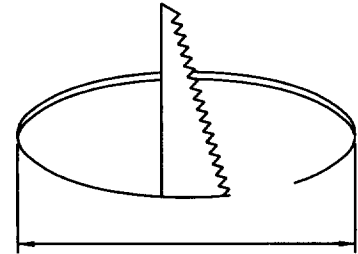

that the metal arms are seated firmly and evenly on the ceiling tile or ceiling tile/bridge combination (see Figure E). Lock the springs into place by pulling back and securing behind the flange in the bracket.

Loudspeaker System Assembly

Before installing the ceiling loudspeaker system it is necessary to pull the hook up wire downwards through the hole in the ceiling and make electrical connection to the terminal block on the rear cover - see *Using Conduit Fittings* section. If required by local regulations a mounting point is provided on the rear cover that can be used for the attachment of a safety chain or wire. (See Figure C)

The speaker assembly can be installed by pushing it through the central opening of the bezel assembly and then rotating the unit until the "pins" on the bezel align with the "bayonet" slots on the grille (see Figure F). Verify the unit has seated firmly.

Removing a Loudspeaker System Assembly

A loudspeaker system can be removed by pushing upwards on the grille and rotating the speaker assembly until the pins on the bezel escape the bayonet slots on the grille (see Figure F). Disconnect the safety chain

Figure E

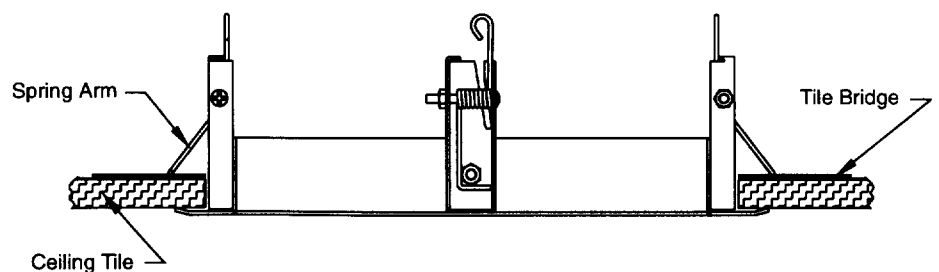

CSP815 Series Full-Range Ceiling Loudspeaker System

or cable, if employed, and disconnect the electrical connection.

Figure F

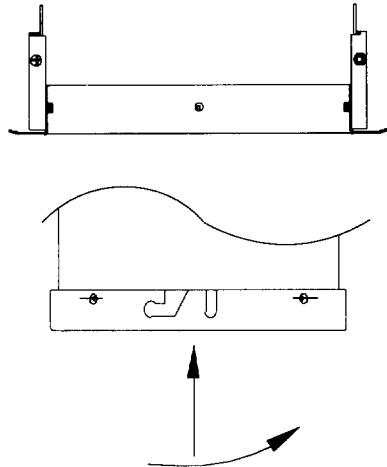

Painting Loudspeaker Assemblies

Bezels

The bezels may be painted before or after installation. Use conventional spray or roller equipment to paint the loudspeaker bezel when the rest of the ceiling is painted. Latex and oil based paints will adhere easily to the loudspeaker bezel, but can scratch if handled carelessly.

Grille/Loudspeaker Assemblies

Brushes or rollers may clog the grilles, interfering with the acoustic performance of the ceiling system. Additionally, a high-pressure spray system may damage the paper cone. Instead, spray paint the grilles with lacquer or enamel paint in aerosol cans. (A professional, siphon-feed spray gun may be used provided the pressure is sufficiently low to prevent cone damage). Place the grille / loudspeaker system on a flat surface facing upwards. Clean the grilles first to remove all possible contaminants. Apply the paint at a 45 degree angle to the grille surface (see Figure G). Rotate the grille 180 degrees and apply a second coat of paint. Alternatively the grille can be removed from the loudspeaker enclosure by the removing the three self-tapping screws in the vertical section of the grille (see Figure F).

Figure G

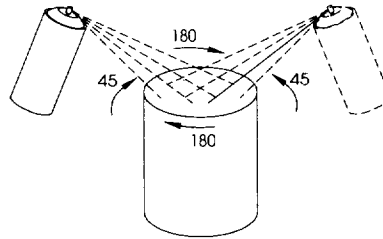

Safety Regulations

All University Sound CSP series of ceiling loudspeaker systems comply with the following standards:

- UL 1480 (general purpose category) [The UL category's ueay, the control number is 86R2 and the file number is E121872]
- UL 2043 (air handling spaces)
- NFPA 70 NEC 1993 Article 300-22 (C) and UL 2043: NFPA 90A-1993 [Installation of air-conditioning and ventilation systems, section 2-3.10.1 (a) exception 2].

Packaging

Please note that all University Sound CSP series ceiling loudspeaker systems are packaged and sold in quantities of (1) or (6). This allows flexibility when ordering a mixed number of units. In addition, the systems are delivered in two containers—pack 1 of 2 contains the bezel assemblies and pack 2 of 2 contains the grille/loudspeaker assemblies. This arrangement allows the sound contractor, when appropriate, to deliver the bezels to the construction site earlier for installation by a subcontractor. The speaker assemblies can be locked in a secure part of the construction site or on the sound contractor's premises until the completion date, when the sound contractor can complete the installation. The optional tile bridge CTB-8 (packaged in quantities of six) must be ordered separately.

Architect's and Engineer's Specifications

CSP815 Ceiling Loudspeaker Systems

The loudspeaker systems shall be comprised of a spring/bezel assembly and a loudspeaker

assembly. The finish of the bezel and grille shall be semigloss white powder-coated enamel. The loudspeaker assembly will contain a premounted loudspeaker, transformer and grille. The loudspeaker shall meet the requirement of UL2043. The loudspeaker will feature a 8-inch curvilinear cone and a high-temperature voice-coil assembly. The loudspeaker shall meet the following criteria: ANSI/EIA RS-426-A 1980 power rating shall be 15 watts of band-limited pink noise (85 Hz to 18 kHz, 6-dB crest factor). Frequency response, uniform from 85 Hz to 18 kHz. Pressure sensitivity, 96 dB SPL at 1 meter (94 dB at 4 feet) on axis with one watt of band-limited pink noise from 500 Hz to 3 kHz (ref. 20 μ Pa). Minimum impedance, 6.0 ohms. A 70-/100-volt transformer will be premounted inside the speaker assembly and offer power taps at 1, 2, 4 and 8 watts (CSP815-8T). The loudspeaker assembly shall be 273 mm (10.74 in.) in diameter and 235 mm (9.26 in.) deep. The unit shall weigh 3.2 kg (7.0 lb). The ceiling loudspeaker package shall be the University Sound CSP 815-8T.

Warranty (Limited)

University Sound products are guaranteed against malfunction due to defects in materials or workmanship for a specified period, as noted in the individual product-line statement(s) below, or in the individual product data sheet or owner's manual, beginning with the date of original purchase. If such malfunction occurs during the specified period, the product will be repaired or replaced (at our option) without charge. The product will be returned to the customer prepaid.

Exclusions and Limitations: The Limited Warranty does not apply to: (a) exterior finish or appearance; (b) certain specific items described in the individual product-line statement(s) below, or in the individual product data sheet or owner's manual; (c) malfunction resulting from use or operation of the product other than as specified in the product data sheet or owner's manual; (d) malfunction resulting from misuse or abuse of the product; or (e) malfunction occurring at any time after repairs have been made to the product by anyone other than University

CSP815 Series Full-Range Ceiling Loudspeaker System

CSP815 Series Full-Range Ceiling Loudspeaker System

Sound or any of its authorized service representatives. **Obtaining Warranty Service:** To obtain warranty service, a customer must deliver the product, prepaid, to University Sound or any of its authorized service representatives together with proof of purchase of the product in the form of a bill of sale or receipted invoice. A list of authorized service representatives is available from University Sound at 600 Cecil Street, Buchanan, MI 49107 (616/695-6831 or 800/234-6831). **Incidental and Consequential Damages Excluded:** Product repair or replacement and return to the customer are the only remedies provided to the customer. University Sound shall not be liable for any incidental or consequential damages including, without limitation, injury to persons or property or loss

of use. Some states do not allow the exclusion or limitation of incidental or consequential damages so the above limitation or exclusion may not apply to you. **Other Rights:** This warranty gives you specific legal rights, and you may also have other rights which vary from state to state. Service and repair address: University Sound, 600 Cecil Street, Buchanan, MI 49107 (616/695-6831 or 800/234-6831). Specifications subject to change without notice. . .

University Sound Speakers and Speaker Systems are guaranteed against malfunction due to defects in materials or workmanship for a period of five (5) years from the date of original purchase. The Limited Warranty does not apply to burned voice coils or malfunctions such as cone and/or coil damage

resulting from improperly designed enclosures. University Sound active electronics associated with the speaker systems are guaranteed for three (3) years from the date of original purchase. Additional details are included in the Uniform Limited Warranty statement.

University Sound Accessories are guaranteed against malfunction due to defects in materials or workmanship for a period of one (1) year from the date of original purchase. Additional details are included in the Limited Warranty statement.

For technical assistance, contact Technical Support at 800/234-6831 or 616/695-6831, M-F, 8:00 a.m. to 5:00 p.m. eastern standard time.

Specifications subject to change without notice.

Figure 1—Polar Response

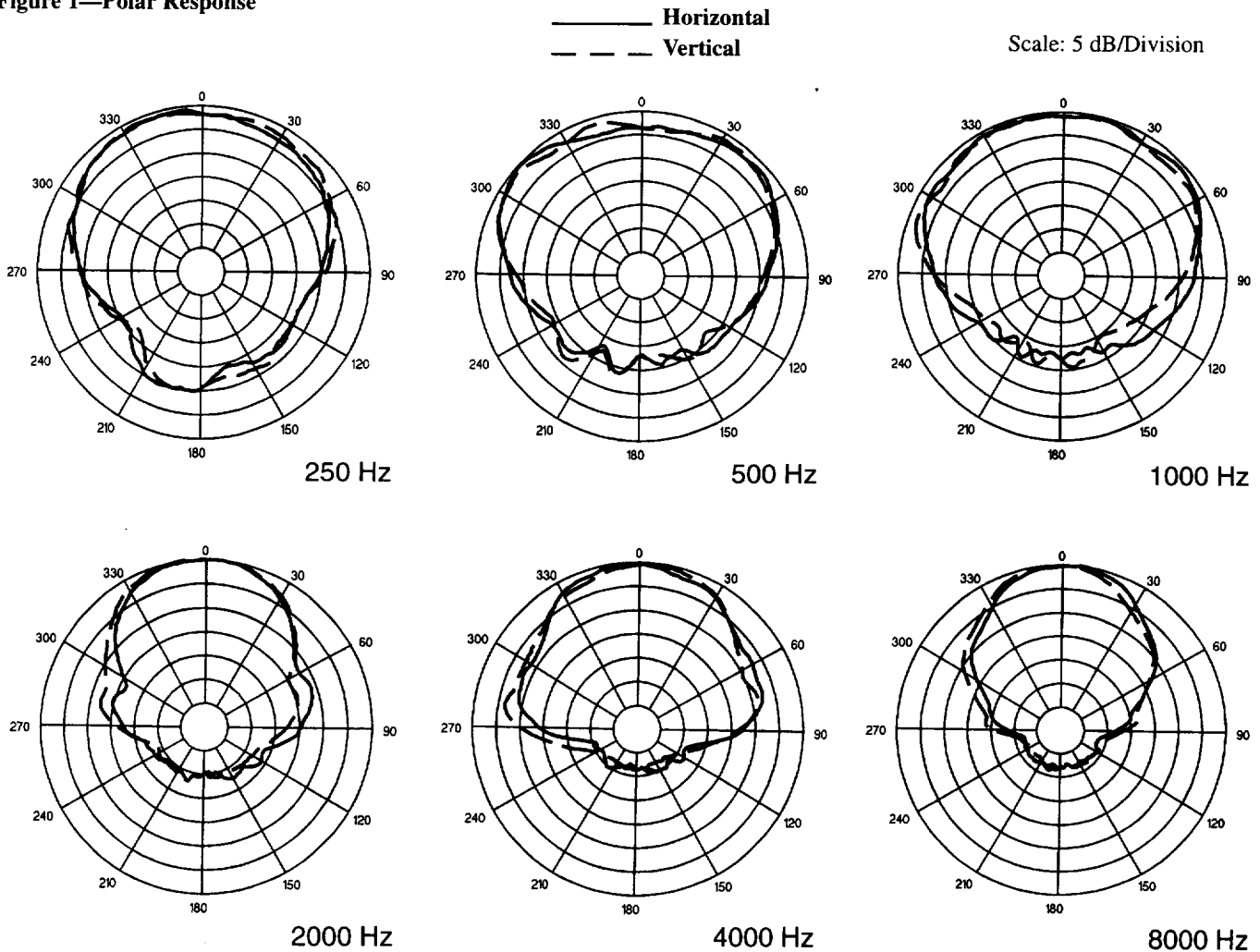

CSP815 Series Full-Range Ceiling Loudspeaker System

CSP815 Series Full-Range Ceiling Loudspeaker System

Figure 2—Frequency Response

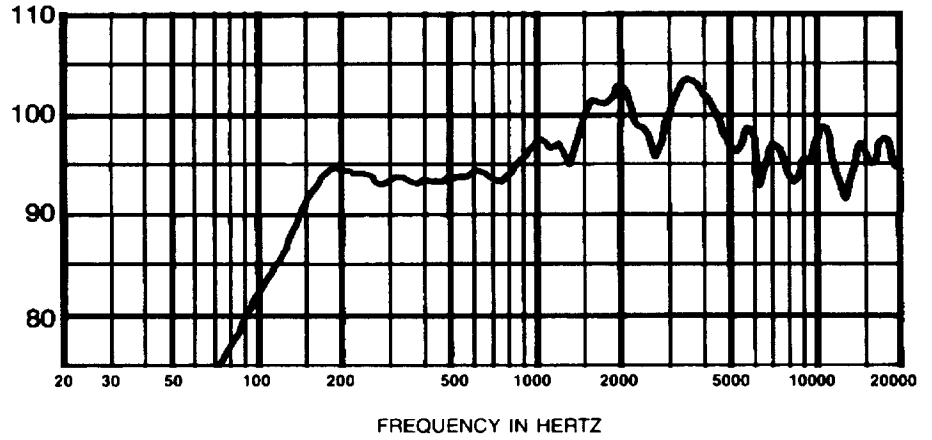

Figure 3—Impedance

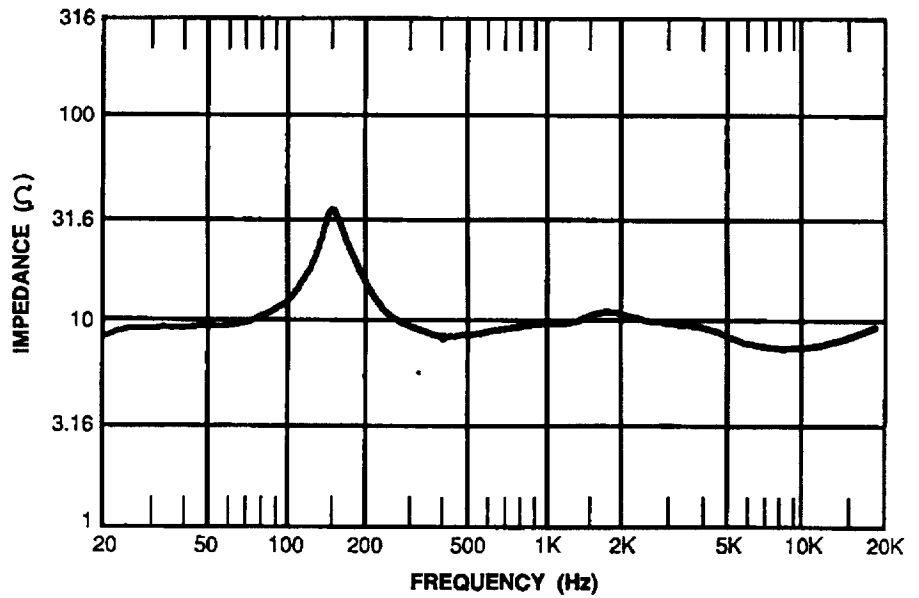
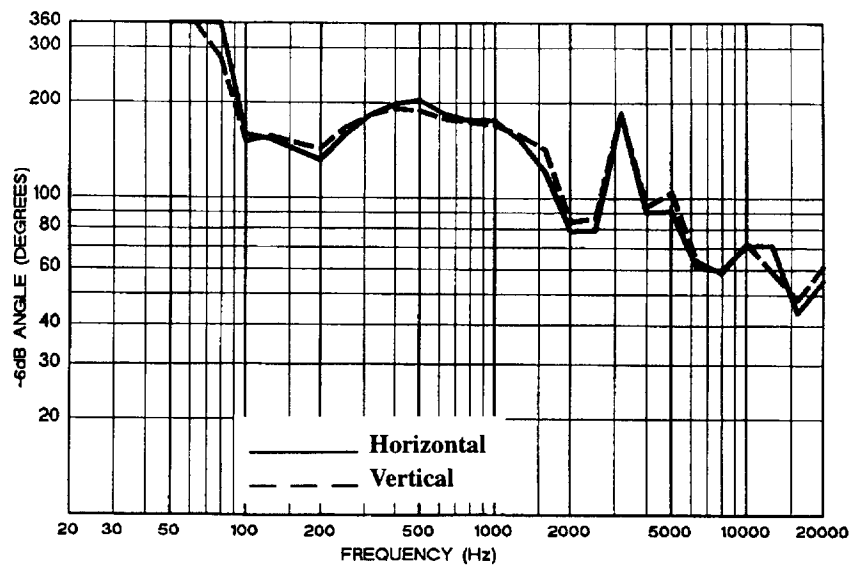

Figure 4—Beamwidth vs. Frequency



CSP815 Series Full-Range Ceiling Loudspeaker System

CSP815 Series Full-Range Ceiling Loudspeaker System

Figure 5—Directivity Factor and Directivity Index vs. Frequency

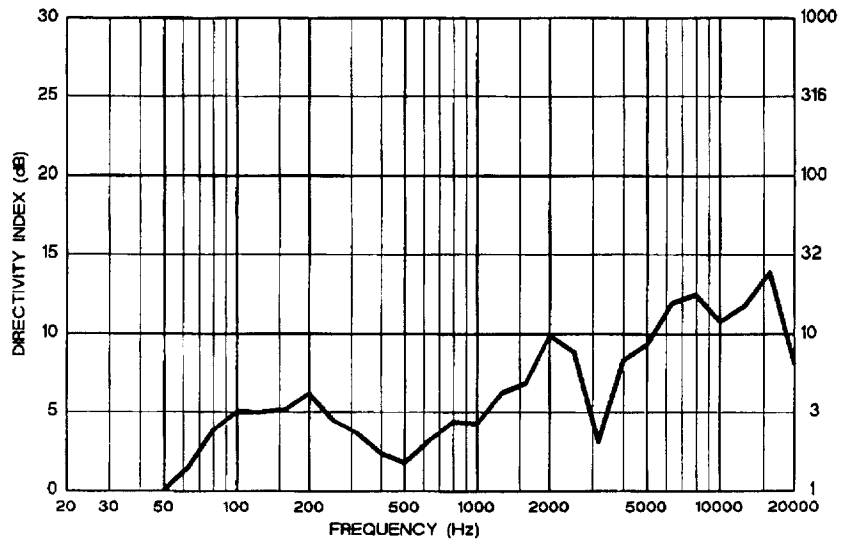
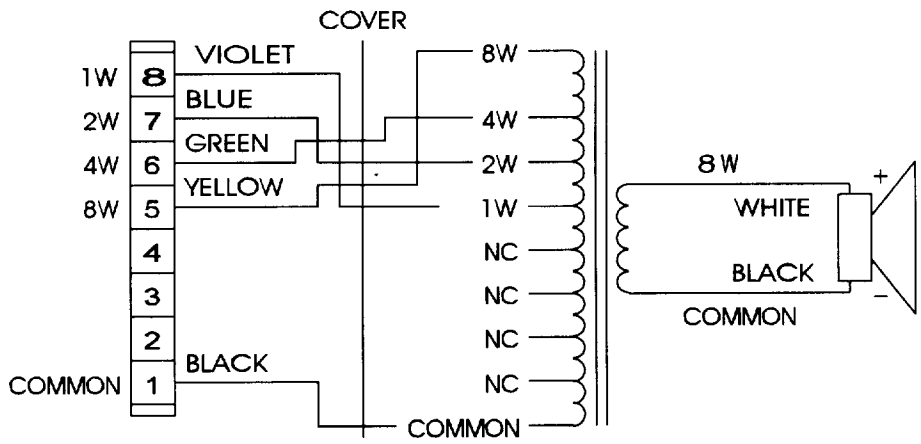
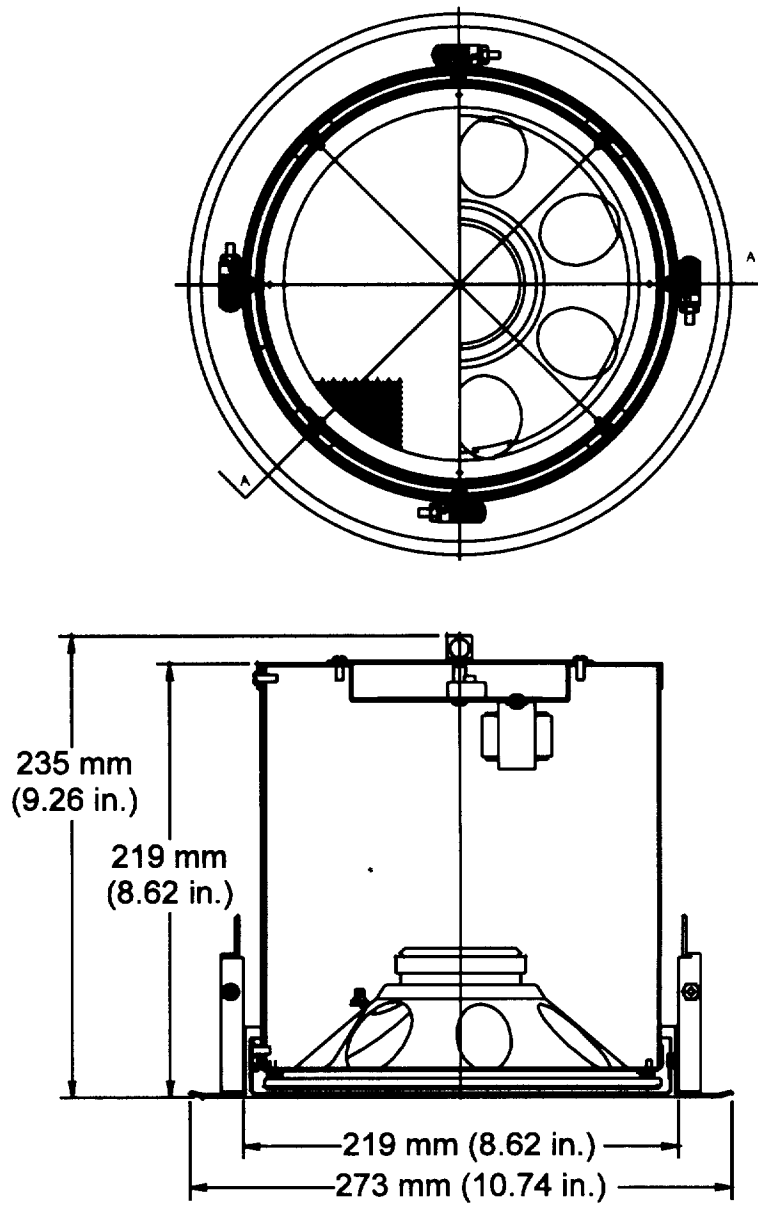

Figure 6—Wiring Diagrams



CSP815 Series Full-Range Ceiling Loudspeaker System

Figure 7—Dimensions



CSP815 Series Full-Range Ceiling Loudspeaker System

CSP815 Series Full-Range Ceiling Loudspeaker System

Specifications

Versions Available:

CSP815-8T—Full-range ceiling loudspeaker system, 8-watt transformer

System Type:

Two-way, full-range coax loudspeaker system

Pressure sensitivity

(1 W, 500 Hz–3,000 Hz, ref.: 20 μ Pa):¹
96 dB SPL

Frequency Response (see Figure 2):²

85 to 18,000 Hz

Power Handling, (85 Hz–18,000 Hz, per ANSI/EIA RS-426-A 1980):³

15 watts

Maximum Long-Term Output,

(15 watts input, 1 m, ref.: 20 μ Pa):⁴
106.5 dB SPL

Impedance,

Nominal:

8.0 ohms

Minimum at 8 kHz:

6.0 ohms

Components:

8-inch, high-efficiency, low-frequency driver with a coaxially mounted, 2.5-in. cone tweeter

Input Terminals:

Eight-way barrier strip with screw- or push-type connectors that will accept up to two #10 AWG wires

Accessories:

CTB-8 ceiling tile bridge

Dimensions,

Loudspeaker Diameter:

273 mm (10.74 in.)

Depth:

235 mm (9.26 in.)

Net Weight:

3.2 kg (7.0 lb)

Shipping Weight:

3.4 kg (7.5 lb)

Finish:

White powder-coated enamel

Transformer Specifications

Frequency Response:

65 Hz to 15 kHz, ± 3 dB

Insertion Loss:

<1.5 dB

Secondary Impedance:

8 ohms

Primary Impedances and Power Drawn, TM8-E:

5,000 ohms / 1.0 watts

2,500 ohms / 2.0 watts

1,250 ohms / 4.0 watts

625 ohms / 8.0 watts

Connection Type:

Eight-way barrier strip that will accept (2) #10 Gauge wires

NOTES ON MEASUREMENT CONDITIONS

1. Pink-noise signal, one watt calculated using E^2/Z_{min} , 3.16 measurement distance referred to one meter.
2. On-axis, one watt calculated using E^2/Z_{min} , 3.16 measurement distance referred to one meter, low frequencies corrected for anechoic chamber error.
3. This system rating patterned after the EIA RS-426-A 1980 method where the test signal is pink noise with a 6-dB crest factor over the bandwidth of the system, with power calculated using E^2/R_E , $\times 1.15$, for eight hours. (Where E is the RMS test voltage and R_E is the dc resistance of the woofer voice coil).
4. This measurement made under the same conditions as Pressure Sensitivity, but at rated power, and takes into account any power compression effects due to non-linearities in the system.



600 Cecil Street, Buchanan, MI 49107
Phone: 616/695-6831, FAX: 616/695-1304