

PIM-122

(standard configuration)

12-Inch, Two-Way System for Permanent Installation, Horn-Loaded HF

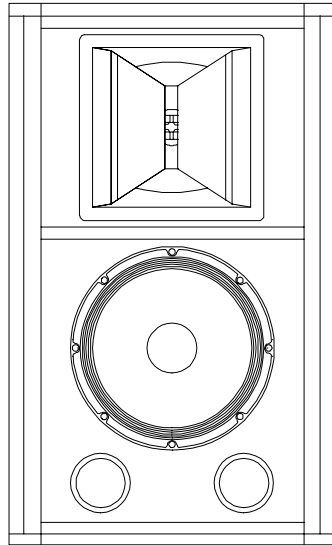

- Part of PI Matrix Series™—compact trapezoidal systems for permanent installation
- Components and physical characteristics optional, to meet many acoustic, architectural and mechanical requirements
- 50-Hz low end for speech and many music applications
- Three HF coverages—60° x 40°, 60° x 60° or 90° x 40° (standard)
- PRO™ circuit HF protection
- For biamplification (standard); passive network optional
- Integral suspension system for safe and easy installation

SPECIFICATIONS

Versions Available:

See PIM-122 ordering matrix (Figure 1)

Typical Axial Frequency Response with Presets of Dx34 Digital Speaker System Processor (swept sine-wave input, anechoic environment, 4 volts at 1 kHz at 10 feet; see Figure 2):
50-18,000 Hz

Typical Axial Frequency Response of High- and Low-Frequency Sections Alone (swept sine-wave input, anechoic environment, 4 volts at 10 feet normalized for 1 watt at 1 meter; see Figure 3):
50-18,000 Hz

Low-Frequency 3-dB-Down Point:
50 Hz

Usable Low-Frequency Limit (10-dB-down point):
35 Hz

Recommended Crossover Frequency:
1,200 Hz

Crossover Slopes, Recommended:
24 dB per octave
Minimum:
12 dB per octave

Long-Term Average Power-Handling Capacity (see Power-Handling Test section),

Low Frequency (per EIA RS-426-A 1980):
300 watts

High Frequency (per AES2-1984/ANSI S4.26-1984):
60 watts

Sensitivity (far-field SPL referred to 1 meter, 1-watt input, anechoic environment, band-limited pink noise),

Low Frequency (100-800 Hz):
95 dB

High Frequency (500-5,000 Hz):
111 dB

SPL at Full Power (far-field SPL at 1 watt/ 1 meter referred to full power, anechoic environment, band-limited pink noise), Long-Term Average/Peak,
Low Frequency (100-800 Hz):
120 dB/126 dB
High Frequency (500-5,000 Hz):
129 dB/135 dB

Impedance,
Nominal (low frequency/ high frequency):
8 ohms/8 ohms
Minimum (low frequency/ high frequency):
8.0 ohms/5.6 ohms

Average Efficiency,
Low Frequency: 4.5%
High Frequency: 25%

Nominal Coverage Angle,
Horizontal: 90°
Vertical: 40°

Beamwidth (angle included by 6-dB-down points on polar responses, indicated one-third-octave bands of pink noise, Dx34 presets employed; see Figure 4):
1,250 to 16,000 Hz Horizontal:
90° (+12°, -10°)
3,150 to 16,000 Hz Vertical:
40° (+9°, -8°)

Directivity Factor R_θ (Q), 500- to 16,000-Hz Median (see Figure 5):
12.8 (+12.6, -9.9)

Directivity Index D_i, 500- to 16,000-Hz Median (see Figure 5):
11.1 dB (+11.0 dB, -9.9 dB)

FIGURE 1 — PIM-122 Ordering Matrix

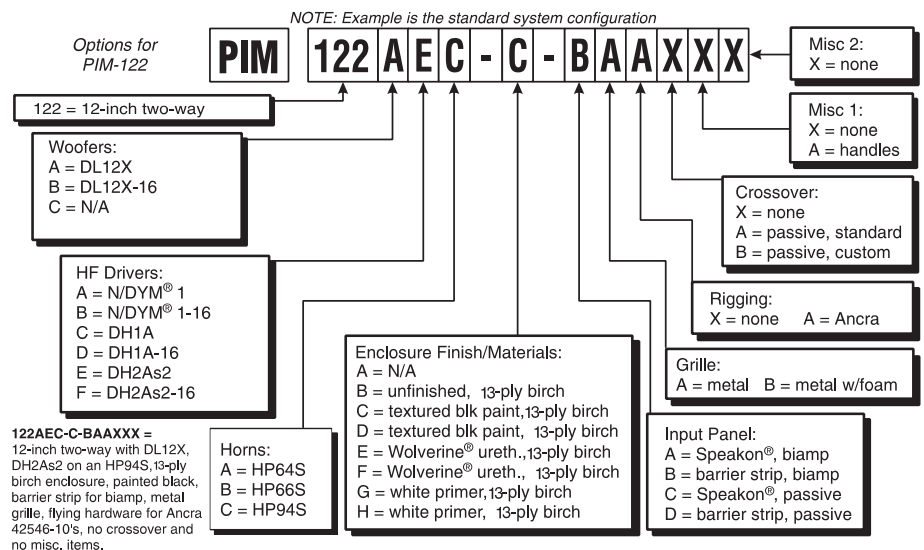

PIM-122 SPECIFICATION GRAPHICS

FIGURE 2 — PIM-122 Typical Axial Frequency Response with Presets of Dx34 Digital Speaker System Processor (swept sine-wave input, anechoic environment, 4 volts at 1 kHz at 10 feet)

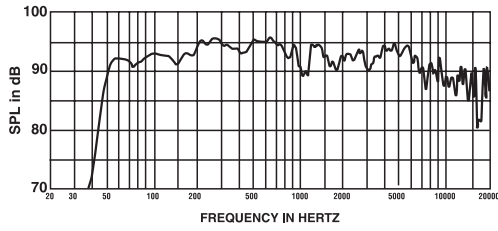

FIGURE 3 — PIM-122 Typical Axial Frequency Response of High- and Low-Frequency Sections Alone (swept sine-wave input, anechoic environment, 4 volts at 10 feet normalized for 1 watt at 1 meter)

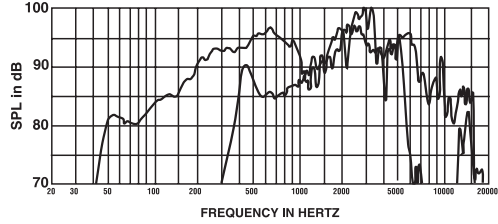

FIGURE 4 — PIM-122 Beamwidth vs. Frequency (one-third-octave bands of pink noise)

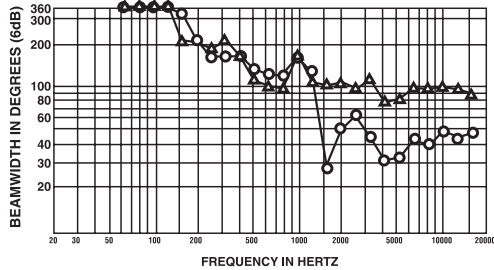

FIGURE 5 — PIM-122 Directivity Factor and Directivity Index vs. Frequency (one-third-octave bands of pink noise)

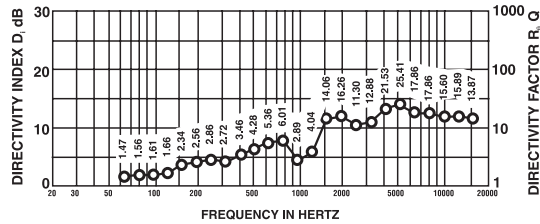

FIGURE 6 — PIM-122 Harmonic Distortion with Dx34 Presets, 10% Rated Input Power at 500 Hz (on axis at 1 meter from system)

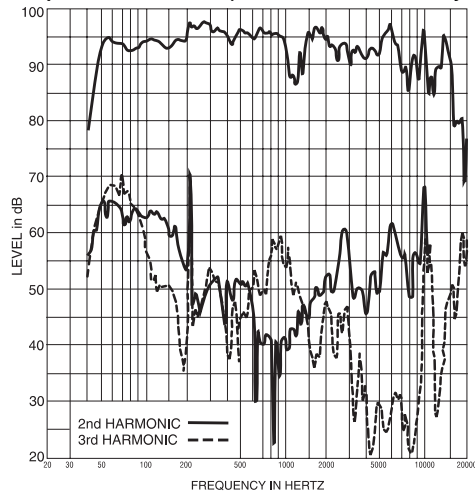

FIGURE 7 — PIM-122 Dimensions

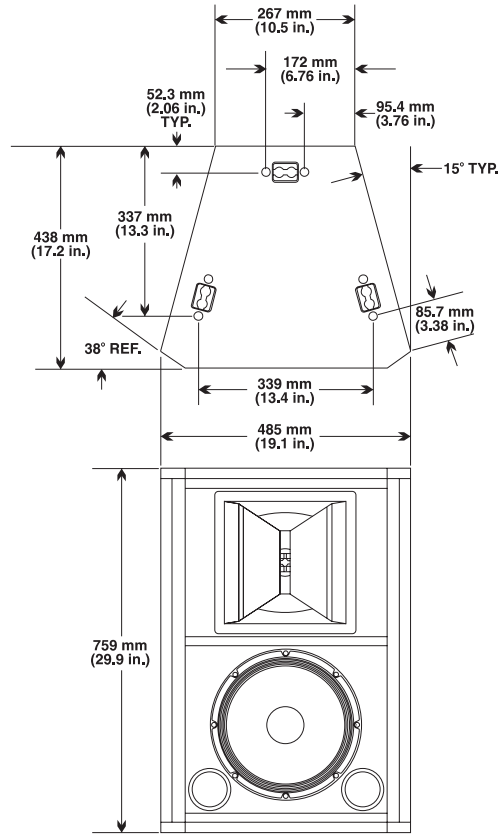
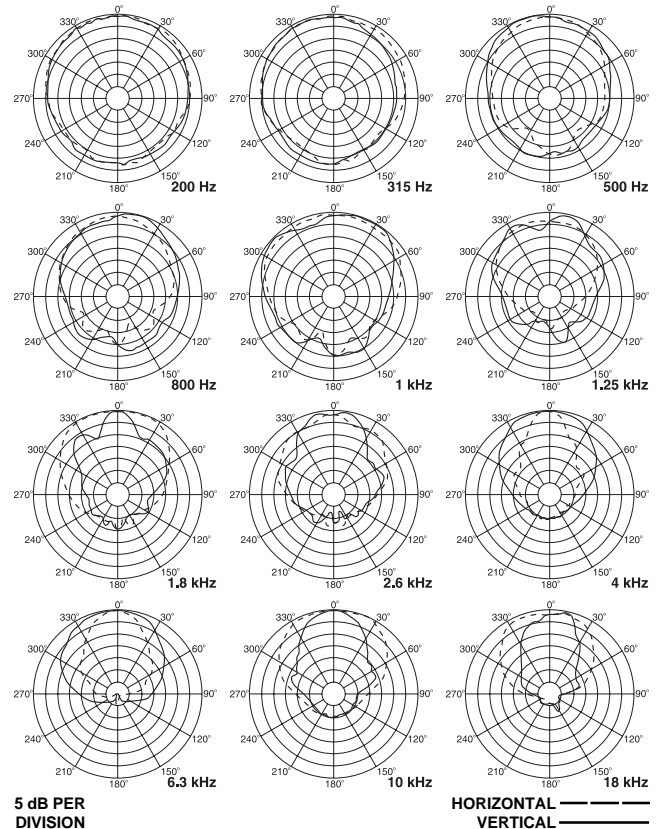

FIGURE 8 — PIM-122 Polar Responses, Selected to Typify Performance (one-third-octave bands of pink noise)



**Distortion Response with Dx34 Presets,
1% Rated Input Power at 500 Hz (on axis
at 1 meter from system),**

Second Harmonic:

100 Hz: <1.0%
1,000 Hz: <1.0%
10,000 Hz: 1.3%

Third Harmonic,

100 Hz: <1.0%
1,000 Hz: <1.0%
10,000 Hz: <1.0%

**Distortion Response with Dx34 Presets,
10% Rated Input Power at 500 Hz (on axis
at 1 meter from system; see Figure 6),**

Second Harmonic,

100 Hz: 2.5%
1,000 Hz: <1.0%
10,000 Hz: 2.5%

Third Harmonic,

100 Hz: 1.4%
1,000 Hz: <1.0%
10,000 Hz: <1.0%

Transducer Complement,

Low Frequency:

DL12X 305-mm (12-in.) woofer
in a vented enclosure

High Frequency:

HP94S 90° x 40° horn mounted
to DH2As2 compression driver with
51-mm (2-inch) exit

Box Tuning Frequency:

45 Hz

Polarity (all drivers):

A positive voltage applied to the positively
marked input terminal produces a positive
acoustic pressure at the front of the
system

**Input Connections, Low Frequency/
High Frequency:**

#10 screw terminals on barrier strip; each
driver can be individually accessed

Driver Protection, High Frequency:

Solid-state self-resetting circuit (PRO™
circuit) drops input 6 dB; blocking
capacitor with 800-Hz corner frequency
and 6-dB-per-octave slope

Enclosure Materials and Color:

Textured black painted 7-ply void-free
birch

Grille:

Black powder coated, vibration-resistant
steel, removable

Suspension:

Integral three-point flying system (accepts
Ancra 42546-10 single-stud tie-down cargo
fitting; four fittings supplied with system;
see Suspending PIM-122 Enclosures
section)

Dimensions (see Figure 7),

Height:

759 mm (29.9 in.)

Width at front:

485 mm (19.1 in.)

Width at rear:

267 mm (10.5 in.)

Depth:

439 mm (17.3 in.)

Side-Wall Draft Angle:

15°

Net Weight:

35.4 kg (78 lb)

Shipping Weight:

40.5 kg (89 lb)

DESCRIPTION AND APPLICATIONS

The Electro-Voice PIM-122 is a compact, trap-
ezoidal two-way speaker system for permanent
installation. The high-frequency section is horn
loaded and the low-frequency section is direct
radiating in an optimally vented enclosure. The

PIM-122 is part of the PI Matrix Series™, a
highly flexible group of full-range and low-
frequency systems for applications where com-
pact systems are appropriate. Many perform-
ing arts centers, clubs, auditoriums, sports
facilities and houses of worship are candidates
for the PI Matrix Series™.

The flexibility of the PI Matrix Series™ allows
the designer to customize a system to both suit
the acoustic environment and meet a wide
variety of architectural and mechanical require-
ments. High-frequency horns have been opti-
mally sized to maintain their rated coverage
patterns down to the chosen crossover fre-
quencies and over as wide a frequency range
as possible. Furthermore, the horns are option-
ally available in three coverage angles (90° x
40°, 60° x 40° and 60° x 60°) to aid in properly
matching a speaker location to the audience
area. In addition, all horns may be rotated about
their axes, for coverage that is independent of
enclosure orientation.

Other PI Matrix Series™ options include low-
and high-frequency drivers, enclosure materi-
als and finish, grilles, suspension hardware and
input-panel connections, giving the sound con-
tractor or consultant literally thousands of com-
binations to satisfy the overall system design
criteria.

The PIM-122 standard configuration is a 90° x
40° two-way full-range system for biamplifica-
tion. The PIM-122 maintains good directivity
control down to 1,500 Hz (see Figure 4). The
low-frequency section incorporates a DL12X
305-mm (12-in.) woofer. The angled enclosure
sides (15°) allow ceiling or under-balcony mount-
ing with a reduced vertical profile and aiming
angle that is inherently in the general direction
of the audience. The enclosure is made of black
painted 7-ply void-free birch and includes cer-
tified flying hardware as standard.

Delivering smooth and extended performance,
the high-frequency section operates from 1,200
to 18,000 Hz and consists of a DH2As2 com-
pression driver coupled to an HP94S 90° x 40°
constant-directivity horn. The HP94S horn fea-
tures integral fiberglass-and-zinc construction
for exceptional strength and performance. Beam-
width-control vanes in the horn throat cor-
rect all coverage anomalies in the 10- to 20-
kHz octave. The driver is protected from over-
drive by the solid-state, self-resetting PRO™
circuit, which drops the input signal by 6 dB.
Additional protection at the low end of the
driver's range is provided by a series blocking
capacitor with a corner frequency of 800 Hz and
slope of 6 dB per octave.

The low-frequency section operates between
50 and 1,200 Hz and has been designed for
superior performance. The DL12X woofer can
handle very large levels of input power, produc-
ing high acoustic output with relatively low
distortion and closely matching the output lev-
els of the high-frequency section.

The PIM-122 is equipped with a number of
additional features to make operation and in-
stallation easy and secure. A proprietary struc-
tural extrusion is incorporated into the en-
closure, providing safe and flexible suspension
(see Suspending PIM-122 Enclosures section).
Up to two enclosures of the same footprint can
be suspended without additional support (as
long as the lower system is not heavier than the
upper system), so arrays can be created quickly
and easily. The grille is composed of vibration-
resistant steel for excellent driver protection,
and an optional foam cover can be added for
better protection when used outdoors. Besides
the standard black-painted finish, the en-
closure can also be ordered primed in white for
painting with ordinary paints, unfinished for
staining, or with our special Wolverine® weather-

resistant finish for outdoor applications. All driv-
ers on the PIM-122 can be serviced from the
front of the enclosure.

**A complete listing of all system options is
shown in Figure 1.**

SUSPENDING PIM-122 ENCLOSURES

*Suspending any object is potentially danger-
ous and should be attempted only by individu-
als who have a thorough knowledge of the
techniques and regulations of hanging over-
head. Electro-Voice strongly recommends that
the PIM-122 be suspended taking into account
all current national, federal, state and local
regulations. It is the responsibility of the in-
staller to ensure the PIM-122 is safely installed
in accordance with all such regulations. If the
PIM-122 is suspended, Electro-Voice strongly
recommends that the system be inspected at
least once a year. If any sign of weakness or
damage is detected, remedial action should be
taken immediately.*

The PI Matrix Series™ enclosures are sus-
pended using the following approach, which
has been approved by an independent struc-
tural engineer. Every enclosure incorporates
six independent suspension points, three on
the top and three on the bottom. A minimum of
three points must be used at all times to sus-
pend the enclosure. The suspension points,
which "tie" the top and sides of the enclosure
together, are made of structural aluminum.
Each suspension point mates to an Ancra
42546-10 locking fitting (four are supplied with
each enclosure ordered with this option, EV
part no. 20562), and each point has a break
strength of 907 kg (2,000 lb) in any direction.¹
A maximum of two enclosures can be "daisy
chained" together, allowing the construction of
vertical arrays. If longer arrays are required,
provision must be made to independently sus-
pend each enclosure. The Ancra 42546-10
fitting incorporates a safety pin to prevent acci-
dental release, and it should be engaged at all
times.

ROTATING THE HIGH-FREQUENCY HORN

The PIM-122 high-frequency horn may be eas-
ily rotated about its major axis, providing cover-
age independent of enclosure orientation. First
remove the enclosure grille, then the horn. Both
are affixed with Phillips-head screws (use a #2
Phillips screwdriver). Rotate the horn 90° about
its axis and reinstall the components.

CONNECTIONS

The option ordered, biamped or passive cross-
over with either barrier-strip or Neutrik Spea-
kon® connectors, will determine the wiring of
the system components.

Biamped Input

If the system is biamped with barrier strips,
each frequency section can be individually ac-
cessed via #10 screw terminals as marked on
the input panels. If Neutrik Speakon® connec-
tors are used, pins 1+/1- are wired to the low-
frequency driver and pins 2+/2- to the high-
frequency section.

Passive Crossover Input

If the passive crossover option is used, both
barrier strips are wired in parallel and pins +1/
-1 on both Neutrik Speakon® connectors are
wired in parallel.

In all cases, drivers are connected with the
same polarity. A positive voltage applied to the
positively marked terminal produces a positive
acoustic pressure at the front of the system.

CROSSOVER, EQ AND SIGNAL DELAY

The PIM-122 is a two-way system which must
be biamped with a separate active crossover. A

1. For additional information, contact Ancra International at
606/371-7272 or toll free (within U.S. only) at 800/233-5138.

1,200-Hz crossover frequency is recommended. Optimum performance and reliability are provided by 24-dB-per-octave slopes. 12-dB-per-octave slopes are the minimum recommended. The low-frequency section should have sub-passband protection using a high-pass filter set at about 30 Hz. No signal delay or further EQ is mandatory but their use can smooth response and directivity, particularly in the region of crossover. The high-frequency section requires the appropriate constant-directivity-horn high-frequency boost EQ for flat response.

The Dx34 digital speaker system processor can be set to provide subpassband protection, crossover, EQ and signal delay for optimum performance of the PIM-122. Contact Electro-Voice for the specific parameter settings. Alternatively, the XEQ-2 or XEQ-3 analog crossover/equalizer/delay networks can be used. High-frequency horn EQ is provided by plug-in modules, the specific model of which is determined by the horn model. The XEQ engineering data sheets provide this specific information.

LOW-FREQUENCY ENHANCEMENT

If it is desirable to enhance low-frequency performance, Electro-Voice recommends, depending on installation requirements, the PIM-151 or PIM-251 PI Matrix Series™ systems as well as any of the TL series or MTL series of Manifold Technology® systems. Contact Electro-Voice for information on these systems.

FREQUENCY RESPONSE

PIM-122 axial frequency responses were measured in Electro-Voice's large anechoic chamber at a distance of 3.0 meters (10 feet) with swept sine-wave input. Figure 2 shows the typical overall system response with presets of the Dx34 digital speaker system processor. Speaker drive voltage is 4 volts at 1 kHz. Figure 3 shows the responses of the individual low- and high-frequency sections with a 4-volt drive, normalized for a 1-watt input and a 1-meter distance.

DIRECTIVITY

The directional characteristics of the PIM-122 were measured in Electro-Voice's large anechoic chamber, with a test signal of one-third-octave filtered pink noise at the frequencies indicated. A full spherical measurement system, which is fully compatible with Mark IV Audio's AcoustaCADD™ computer aided design program, was used. All directional information was measured at 6.1 meters (20 feet).

Figure 8 illustrates the nominal horizontal and vertical polar responses, with the long system axis vertical. If the high-frequency horn is rotated, then the horizontal and vertical polars should be interchanged.

Figure 4 illustrates the horizontal and vertical beamwidths. Beamwidth is the angle at which the horizontal and vertical polar responses have decreased in level by 6-dB when compared to the on-axis frequency response.

Figure 5 represents the total directivity of the PIM-122. The directivity factor R_0 (Q) is the relative value, at a point, when compared to an ideal spherical response. The directivity index (D_i) is calculated by $D_i = 10 \log_{10} R_0$.

SERVICE

In the unlikely event the PIM-122 requires service, each driver can be replaced or serviced from the front. A service data sheet is available from Electro-Voice.

POWER-HANDLING TEST

Electro-Voice components and systems are manufactured to exacting standards, ensuring they will hold up, not only through the most rigorous of power tests, but also through continued use in arduous, real-life conditions. Two main test specifications are used: the AES Recommended Practice for Specification of Loudspeaker Components Used in Professional Audio and Sound Reinforcement (AES2-1984 / ANSI S4.26-1984) and the EIA Loudspeaker Power Rating Full Range (ANSI / EIA RS426-A 1980). Both of these specifications use random-noise spectrum which mimic typical music and test the thermal and mechanical capabilities of the components. Electro-Voice will support relevant additional standards as and when they become available. Extreme, in-house power tests, which push the performance boundaries of the components, are also performed and passed to ensure years of trouble free service.

Specifically, the PIM-122 high-frequency section passes AES2-1984/ANSI S4.26-1984 with the following values:

$Z_{min} = 5.6$ ohms at 7,000 Hz
 $P_{E(max)} = 60$ watts
 Test voltage = 18.3 volts rms
 36.7 volts peak (+6 dB)
 Selected decade = 1,500-15,000 Hz

The PIM-122 low-frequency passes ANSI/EIA RS-426-A 1980 with the following values:

$R_{SR} = 6.9$ ohms ($1.15 \times R_E$)
 $P_{E(max)} = 300$ Watts
 Test voltage = 45.5 volts rms
 91.0 volts peak (+6 dB)

ARCHITECTS' AND ENGINEERS' SPECIFICATIONS

The loudspeaker shall be a two-way system for bi-amplification. Low frequencies shall be reproduced by an 8-ohm 305-mm (12-in.) woofer with an edge-wound flat-wire 63.5-mm (2.5-in.) voice coil capable of handling 300 watts long term per ANSI/EIA RS-426-A and with a sensitivity of 95 dB 1 watt/1 meter. High frequencies shall be reproduced by an 8-ohm compression driver with a 76.2-mm (3-in.) diaphragm and a 51-mm (2-in.) exit, capable of handling 60 watts long term per AES2-1984/ANSI S4.26-1984, coupled to a constant-directivity horn with a 90° x 40° coverage pattern and with a sensitivity of 112 dB. The high-frequency horn shall be rotatable 90° about its axis within the enclosure. The system shall reproduce frequencies from 50 to 18,000 Hz and have a nominal coverage pattern of 90° x 40°, with directivity control maintained down to 1,500 Hz. The recommended crossover frequency shall be 1,200 Hz. Maximum average sound pressure levels at 1 meter shall be 120 dB (low-frequency section) and 129 dB (high-frequency section), with short-term peaks 6 dB higher.

The enclosure shall be constructed of 7-ply void-free birch and finished in black textured paint. The enclosure shall have a trapezoidal footprint. Dimensions shall be 759 mm (29.9 in.) high, 485 mm (19.1 in.) wide at the front, 267 mm (10.5 in.) wide at the rear and 438 mm (17.3 in.) deep. Enclosure sides shall have a 15° draft angle. The enclosure shall have a suspension system approved by an independent structural engineer and consisting of three independent suspension points on the top and three on the bottom, all of which shall mate with Ancra 42546-10 fittings. Net weight shall be 35.4 kg (78 lb).

The loudspeaker system shall be the Electro-Voice PIM-122.

Note: the PIM-122 described above is the standard configuration. Acoustic and mechanical details will vary when different options are supplied.

UNIFORM LIMITED WARRANTY

Electro-Voice products are guaranteed against malfunction due to defects in materials or workmanship for a specified period, as noted in the individual product-line statement(s) below, or in the individual product data sheet or owner's manual, beginning with the date of original purchase. If such malfunction occurs during the specified period, the product will be repaired or replaced (at our option) without charge. The product will be returned to the customer prepaid. **Exclusions and Limitations:** The Limited Warranty does not apply to: (a) exterior finish or appearance; (b) certain specific items described in the individual product-line statement(s) below, or in the individual product data sheet or owner's manual; (c) malfunction resulting from use or operation of the product other than as specified in the product data sheet or owner's manual; (d) malfunction resulting from misuse or abuse of the product; or (e) malfunction occurring at any time after repairs have been made to the product by anyone other than Electro-Voice or any of its authorized service representatives. **Obtaining Warranty Service:** To obtain warranty service, a customer must deliver the product, prepaid, to Electro-Voice or any of its authorized service representatives together with proof of purchase of the product in the form of a bill of sale or receipted invoice. A list of authorized service representatives is available from Electro-Voice at 600 Cecil Street, Buchanan, MI 49107 (616/695-6831 or 800/234-6831). **Incidental and Consequential Damages Excluded:** Product repair or replacement and return to the customer are the only remedies provided to the customer. Electro-Voice shall not be liable for any incidental or consequential damages including, without limitation, injury to persons or property or loss of use. Some states do not allow the exclusion or limitation of incidental or consequential damages so the above limitation or exclusion may not apply to you. **Other Rights:** This warranty gives you specific legal rights, and you may also have other rights which vary from state to state.

Electro-Voice Speakers and Speaker Systems are guaranteed against malfunction due to defects in materials or workmanship for a period of five (5) years from the date of original purchase. The Limited Warranty does not apply to burned voice coils or malfunctions such as cone and/or coil damage resulting from improperly designed enclosures. Electro-Voice active electronics associated with the speaker systems are guaranteed for three (3) years from the date of original purchase. Additional details are included in the Uniform Limited Warranty statement.

Electro-Voice Flying Hardware (including enclosure-mounted hardware and rigging accessories) is guaranteed against malfunction due to defects in materials or workmanship for a period of one (1) year from the date of original purchase. Additional details are included in the Uniform Limited Warranty statement.

Electro-Voice Accessories are guaranteed against malfunction due to defects in materials or workmanship for a period of one (1) year from the date of original purchase. Additional details are included in the Uniform Limited Warranty statement.

Service and repair address for this product: Electro-Voice, Inc., 600 Cecil Street, Buchanan, Michigan 49107 (616/695-6831 or 800/234-6831).

Specifications subject to change without notice.



ELECTRO-VOICE a MARK IV company 600 Cecil Street, Buchanan, Michigan 49107

MANUFACTURING PLANTS AT ■ BUCHANAN, MI ■ NEWPORT, TN ■ SEVIERVILLE, TN ■ OKLAHOMA CITY, OK ■ GANANOQUE, ONT.
 © Electro-Voice, Inc. 1995 ■ Litho in U.S.A. Part Number 532701 — 9528